

PLEASE CHECK WWW.MOLEX.COM FOR LATEST PART INFORMATION

Part Number: [0016020087](#)
Status: **Active**
Overview: [cgrid_sl_products](#)
Description: SL™ Crimp Terminal 70058, 22-24 AWG, Reel Selective Gold (Au)

Documents:

Drawing (PDF)	Product Specification PS-70400 (PDF)
Product Specification PS-51008-001 (PDF)	RoHS Certificate of Compliance (PDF)
Product Specification PS-70058 (PDF)	

General

Product Family	Crimp Terminals
Series	70058
Crimp Quality Equipment	Yes
Overview	cgrid_sl_products
Product Name	SL™

Physical

Gender	Female
Material - Metal	Phosphor Bronze
Material - Plating Mating	Gold
Material - Plating Termination	Tin
Packaging Type	Reel
Plating min: Mating (µin)	15
Plating min: Mating (µm)	0.375
Plating min: Termination (µin)	75
Plating min: Termination (µm)	1.875
Termination Interface: Style	Crimp or Compression
Wire Insulation Diameter	1.63mm (.064") max.
Wire Size AWG	22, 24
Wire Size mm²	N/A

Material Info

Old Part Number	70058-0024
-----------------	------------

Reference - Drawing Numbers

Packaging Specification	PK-70873-1300
Product Specification	PS-51008-001, PS-70058, PS-70400
Sales Drawing	SD-70058-0024
Test Summary	TS-70058-001

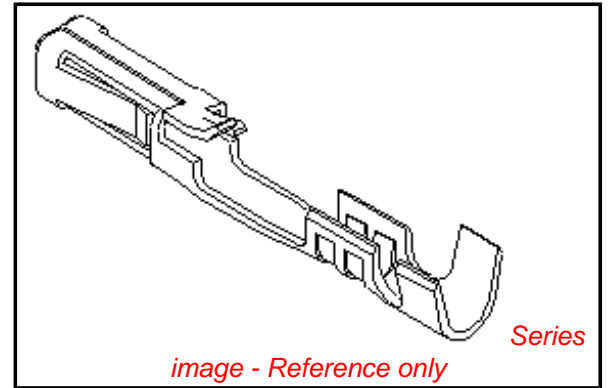

EU RoHS

**ELV and RoHS
Compliant**
**REACH SVHC
Contains SVHC: No**
**Halogen-Free
Status**

China RoHS



**Need more information on product
environmental compliance?**

Email productcompliance@molex.com
 For a multiple part number RoHS Certificate of Compliance, [click here](#)

Please visit the [Contact Us](#) section for any non-product compliance questions.

Search Parts in this Series

[70058Series](#)

Application Tooling | [FAQ](#)

Tooling specifications and manuals are found by selecting the products below. Crimp Height Specifications are then contained in the Application Tooling Specification document.

Global

Description	Product #
Hand Crimp Tool	0638118700
FineAdjust™	0639003200
Applicator for SL™ Crimp Terminals 20-24 AWG	
T2 Terminator	0639103200
Tooling Die	
Insertion Tool	0011020022
Extraction Tool	0011030036

Japan

Description	Product #
-------------	-----------

Side-Feed Applicator 0570143200
For Full-Auto
Machine

This document was generated on 05/18/2010

PLEASE CHECK WWW.MOLEX.COM FOR LATEST PART INFORMATION

NOTES:

1. TERMINAL TO BE USED IN HOUSINGS 70066-**** AND 70450-****
2. REFER TO PRODUCT SPECIFICATION PS-70058
3. REFER TO MOLEX OPERATIONS AND SERVICE MANUAL FOR CRIMP DETAILS
4. TERMINAL TO BE USED WITH (0.64)/.025 SQUARE PINS
5. TERMINAL TO BE USED WITH 22-24 AWG STRANDED WIRE WITH (1.63)/.064 MAX. DIA. INSULATION
6. TERMINALS SUPPLIED IN REEL FORM
7. CRIMP SIZE INDICATOR C=22-24 AWG

*THE PRIMARY SHIPPING CARTON WILL BE LABELED "COMPLIANT TO RoHS DIRECTIVE 2002/95/EC AND ELV ANNEX II OF DIRECTIVE 2000/53/EC". CARTONS WITHOUT THIS LABEL MAY CONTAIN PRODUCT WITH LEAD.

PLATING:

.000015 MIN. GOLD PLATE IN SELECT AREA,
 .000075 MIN. TIN PLATE IN SELECT AREA,
 OVER NICKEL PLATE OVERALL.

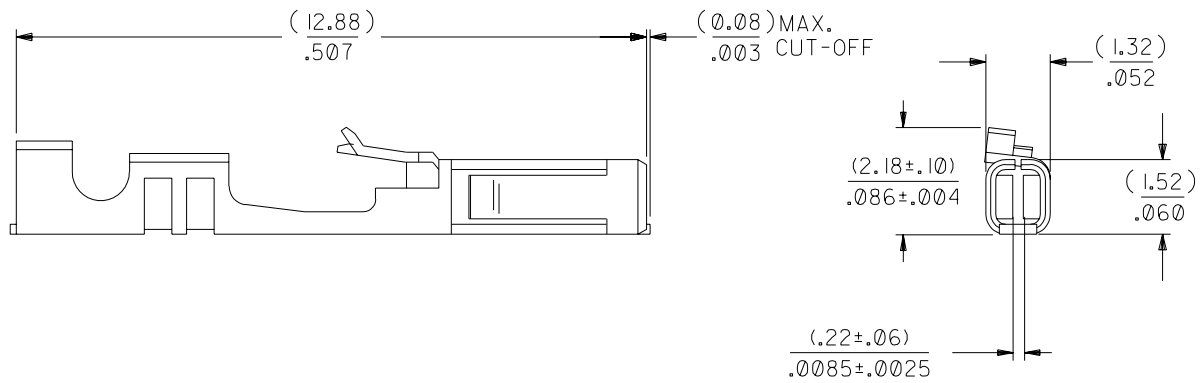
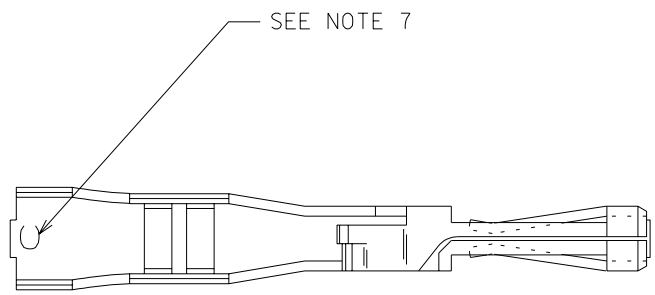

		DI	REVISED ECR #U80270 MCGRATH 97/07/31
E	LEAD FREE UCP2004-1769 RWHITE 04/03/11	D	REVISE PER ECR# U82218 11-07-88 MJM/MGB
D2	ADD CRP SIZE&NOTE 7 ECN UDT1998-0183 MOWANG 04/17/98	C	REDRAWN & REVISED PER ECR #U81133 03/02/88 MJM/JAS
LTR.	REVISIONS	LTR.	REVISIONS

DIMENSIONS SHOWN (METRIC) INCH	
UNLESS OTHERWISE SPECIFIED TOLERANCES: ANGULAR ± 1/2°	
3 PLACE	± .005 ---
2 PLACE	± .01 ± 0.13
1 PLACE	--- ± 0.25
DRAFT WHERE APPLICABLE MUST REMAIN WITHIN DIMENSIONS	
DRWG. BY: JAS	CHK'D. BY:
APP'D. BY:	SCALE 10:1

▽ = 0	▼ = 0	REVISE ONLY ON CAD SYSTEM	
TITLE TERMINAL - BOX/CRIMP			
MOLEX INCORPORATED LISLE, ILL. 60532 U.S.A.		SHEET NO. 1 OF 1	DATE 03/02/88
PART NO. 016-02-0087		DRWG. NO. SD-70058-0024	
FILE NAME S70058C5 DGN	THIS DRAWING CONTAINS INFORMATION THAT IS PROPRIETARY TO MOLEX INC. AND SHOULD NOT BE USED WITHOUT WRITTEN PERMISSION.		DIV. SIZE DA B