



numonyx™

M29DW128F

128 Mbit (16Mb x8 or 8Mb x16, Multiple Bank, Page, Boot Block)
3V supply Flash memory

Feature summary

- Supply voltage
 - $V_{CC} = 2.7V$ to $3.6V$ for Program, Erase and Read
 - $V_{PP} = 12V$ for Fast Program (optional)
 - Asynchronous Random/Page Read
 - Page width: 8 Words
 - Page access: 25, 30ns
 - Random access: 60, 70ns
 - Programming time
 - $10\mu s$ per Byte/Word typical
 - 4 Words / 8 Bytes Program
 - 32-Word Write Buffer
 - Erase Verify
 - Memory blocks
 - Quadruple Bank Memory Array: 16Mbit+48Mbit+48Mbit+16Mbit
 - Parameter Blocks (at Top and Bottom)
 - Dual Operation
 - While Program or Erase in one bank, Read in any of the other banks
 - Program/Erase Suspend and Resume modes
 - Read from any Block during Program Suspend
 - Read and Program another Block during Erase Suspend
 - Unlock Bypass Program
 - Faster Production/Batch Programming
 - Common Flash Interface
 - 64 bit Security Code
 - 100,000 Program/Erase cycles per block
- Low power consumption
 - Standby and Automatic Standby
 - Hardware Block Protection
 - V_{PP}/\overline{WP} Pin for fast program and write protect of the four outermost parameter blocks
 - Security features
 - Standard Protection
 - Password Protection
 - Extended Memory Block
 - Extra block used as security block or to store additional information
 - Electronic Signature
 - Manufacturer Code: 0020h
 - Device Code: 227Eh + 2220h + 2200h
 - ECOPACK® packages available

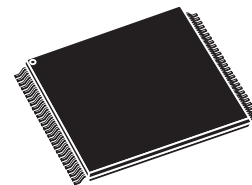

TSOP56 (NF)
14 x 20mm

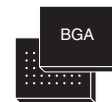

TBGA64 (ZA)
10 x 13mm

Contents

- 1 Summary description 8**

- 2 Signal descriptions 14**
 - 2.1 Address Inputs (A0-A22) 14
 - 2.2 Data Inputs/Outputs (DQ0-DQ7) 14
 - 2.3 Data Inputs/Outputs (DQ8-DQ14) 14
 - 2.4 Data Input/Output or Address Input (DQ15A–1) 14
 - 2.5 Chip Enable (E) 14
 - 2.6 Output Enable (G) 14
 - 2.7 Write Enable (\overline{W}) 15
 - 2.8 V_{PP} /Write Protect (V_{PP}/WP) 15
 - 2.9 Reset/Block Temporary Unprotect (RP) 16
 - 2.10 Ready/Busy Output (RB) 16
 - 2.11 Byte/Word Organization Select (BYTE) 16
 - 2.12 V_{CC} supply voltage (2.7V to 3.6V) 17
 - 2.13 V_{SS} Ground 17

- 3 Bus operations 18**
 - 3.1 Bus Read 18
 - 3.2 Bus Write 18
 - 3.3 Output Disable 18
 - 3.4 Standby 18
 - 3.5 Automatic Standby 19
 - 3.6 Special Bus operations 19
 - 3.6.1 Read Electronic Signature 19
 - 3.6.2 Verify Extended Block Protection Indicator 19
 - 3.6.3 Verify Block Protection Status 19
 - 3.6.4 Hardware Block Protect 19
 - 3.6.5 Temporary Unprotect of high voltage Protected Blocks 20

- 4 Hardware Protection 22**
 - 4.1 Write Protect 22

4.2	Temporary Block Unprotect	22
5	Software Protection	23
5.1	Standard Protection mode	23
5.1.1	Block Lock/Unlock Protection	23
5.1.2	Non-Volatile Protection	24
5.2	Password Protection mode	24
5.2.1	Block Lock/Unlock Protection	25
5.2.2	Non-Volatile Protection	25
6	Command interface	27
6.1	Standard commands	27
6.1.1	Read/Reset command	27
6.1.2	Auto Select command	27
6.1.3	Read CFI Query command	28
6.1.4	Blank Verify command	28
6.1.5	Chip Erase command	28
6.1.6	Block Erase command	30
6.1.7	Erase Suspend command	30
6.1.8	Erase Resume command	31
6.1.9	Program Suspend command	31
6.1.10	Program Resume command	31
6.1.11	Program command	32
6.2	Fast Program commands	35
6.2.1	Write to Buffer and Program command	36
6.2.2	Write to Buffer and Program Confirm command	37
6.2.3	Write to Buffer and Program Abort and Reset command	37
6.2.4	Double Word Program command	37
6.2.5	Quadruple Word Program command	37
6.2.6	Double byte Program Command	37
6.2.7	Quadruple byte Program command	38
6.2.8	Octuple byte Program command	38
6.2.9	Unlock Bypass command	38
6.2.10	Unlock Bypass Program command	39
6.2.11	Unlock Bypass Reset command	39
6.3	Block Protection commands	41
6.3.1	Enter Extended Block command	41

6.3.2	Exit Extended Block command	41
6.3.3	Set Extended Block Protection bit command	42
6.3.4	Verify Extended Block Protection bit command	42
6.3.5	Password Program command	42
6.3.6	Password Verify command	43
6.3.7	Password Protection Unlock command	43
6.3.8	Set Password Protection mode command	43
6.3.9	Verify Password Protection mode command	43
6.3.10	Set Standard Protection mode command	44
6.3.11	Verify Standard Protection mode command	44
6.3.12	Set Non-Volatile Modify Protection bit command	44
6.3.13	Verify Non-Volatile Modify Protection bit command	44
6.3.14	Clear Non-Volatile Modify Protection bits command	45
6.3.15	Set Lock bit command	45
6.3.16	Clear Lock bit command	45
6.3.17	Verify Lock bit command	45
6.3.18	Set Lock-Down bit command	45
6.3.19	Verify Lock-Down bit command	45
7	Status Register	49
7.1	Data Polling bit (DQ7)	49
7.2	Toggle bit (DQ6)	49
7.3	Error bit (DQ5)	50
7.4	Erase Timer bit (DQ3)	50
7.5	Alternative Toggle bit (DQ2)	50
7.6	Write to Buffer and Program Abort bit (DQ1)	50
8	Dual Operations and Multiple Bank architecture	53
9	Maximum rating	55
10	DC and AC parameters	56
11	Package mechanical	66
12	Part numbering	68

Appendix A Block addresses and Read/Modify Protection Groups 69

Appendix B Common Flash Interface (CFI) 78

Appendix C Extended Memory Block 83

 C.1 Factory Locked Section of the Extended Block 83

 C.2 Customer Lockable Section of the Extended Block. 84

Appendix D High Voltage Block Protection 85

 D.1 Programmer technique 85

 D.2 In-System technique 86

Appendix E Flowcharts 87

Revision history 93

List of tables

Table 1.	Signal names	9
Table 2.	Bank architecture	10
Table 3.	Bus operations, 8-bit mode	20
Table 4.	Read Electronic Signature, 8-bit mode	20
Table 5.	Block Protection, 8-bit mode	20
Table 6.	Bus operations, 16-bit mode	21
Table 7.	Read Electronic Signature, 16-bit mode	21
Table 8.	Block Protection, 16-bit mode	21
Table 9.	Hardware Protection	22
Table 10.	Block Protection status	25
Table 11.	Standard Commands, 8-bit mode	33
Table 12.	Standard Commands, 16-bit mode	34
Table 13.	Fast Program Commands, 8-bit mode	39
Table 14.	Fast Program Commands, 16-bit mode	40
Table 15.	Block Protection Commands, 8-bit mode	46
Table 16.	Block Protection Commands, 16-bit mode	46
Table 17.	Protection Command Addresses	48
Table 18.	Program, Erase Times and Program, Erase Endurance Cycles	48
Table 19.	Status Register bits	51
Table 20.	Dual Operations allowed in other Banks	53
Table 21.	Dual Operations allowed in same Bank	54
Table 22.	Absolute maximum ratings	55
Table 23.	Operating and AC measurement conditions	56
Table 24.	Device capacitance	57
Table 25.	DC Characteristics	57
Table 26.	Read AC characteristics	60
Table 27.	Write AC characteristics, Write Enable Controlled	61
Table 28.	Write AC characteristics, Chip Enable Controlled	62
Table 29.	Toggle and Alternative Toggle bits AC characteristics	63
Table 30.	Reset/Block Temporary Unprotect AC characteristics	65
Table 31.	TSOP56 – 56 lead Plastic Thin Small Outline, 14 x 20mm, package mechanical data	66
Table 32.	TBGA64 10x13mm - 8x8 active ball array, 1mm pitch, package mechanical data	67
Table 33.	Ordering information scheme	68
Table 34.	Block Addresses and Protection Groups	69
Table 35.	Query Structure Overview	78
Table 36.	CFI Query Identification String	78
Table 37.	CFI Query System Interface information	79
Table 38.	Device Geometry Definition	80
Table 39.	Primary Algorithm-Specific Extended Query table	81
Table 40.	Security Code Area	82
Table 41.	Extended Block Address and Data	84
Table 42.	Programmer technique Bus operations, 8-bit or 16-bit mode	86
Table 43.	Document revision history	93

List of figures

Figure 1.	Logic diagram	9
Figure 2.	TSOP connections	10
Figure 3.	TBGA connections (top view through package)	11
Figure 4.	Block Addresses (x8)	12
Figure 5.	Block Addresses (x16)	13
Figure 6.	Block Protection State diagram	26
Figure 7.	Software Protection scheme	26
Figure 8.	Data Polling flowchart	51
Figure 9.	Toggle flowchart	52
Figure 10.	AC measurement I/O waveform	56
Figure 11.	AC measurement Load Circuit	56
Figure 12.	Random Read AC waveforms	58
Figure 13.	Page Read AC waveforms	59
Figure 14.	Write AC waveforms, Write Enable Controlled	61
Figure 15.	Write AC waveforms, Chip Enable Controlled	62
Figure 16.	Toggle and Alternative Toggle bits mechanism, Chip Enable Controlled	63
Figure 17.	Toggle and Alternative Toggle bits mechanism, Output Enable Controlled	63
Figure 18.	Reset/Block Temporary Unprotect AC waveforms (No Program/Erase ongoing)	64
Figure 19.	Reset/Block Temporary Unprotect During Program/Erase Operation AC waveforms	64
Figure 20.	Accelerated Program Timing waveforms	64
Figure 21.	TSOP56 – 56 lead Plastic Thin Small Outline, 14 x 20mm, package outline	66
Figure 22.	TBGA64 10x13mm - 8x8 active ball array, 1mm pitch, package outline	67
Figure 23.	Programmer equipment Group Protect flowchart	87
Figure 24.	Programmer equipment Chip Unprotect flowchart	88
Figure 25.	In-System equipment Group Protect flowchart	89
Figure 26.	In-System equipment Chip Unprotect flowchart	90
Figure 27.	Write to Buffer and Program flowchart and Pseudo Code	91

1 Summary description

The M29DW128F is a 128 Mbit (16Mb x8 or 8Mb x16) non-volatile memory that can be read, erased and reprogrammed. These operations can be performed using a single low voltage (2.7 to 3.6V) supply. At Power-up the memory defaults to its Read mode.

The M29DW128F features an asymmetrical block architecture, with 16 parameter and 254 main blocks, divided into four Banks, A, B, C and D, providing multiple Bank operations. While programming or erasing in one bank, read operations are possible in any other bank. The bank architecture is summarized in *Table 2*. Eight of the Parameter Blocks are at the top of the memory address space, and eight are at the bottom.

Program and Erase commands are written to the Command Interface of the memory. An on-chip Program/Erase Controller simplifies the process of programming or erasing the memory by taking care of all of the special operations that are required to update the memory contents. The end of a program or erase operation can be detected and any error conditions identified. The command set required to control the memory is consistent with JEDEC standards. The Chip Enable, Output Enable and Write Enable signals control the bus operations of the memory. They allow simple connection to most microprocessors, often without additional logic.

The device supports Asynchronous Random Read and Page Read from all blocks of the memory array.

The M29DW128F has one extra 256 byte block (Extended Block) that can be accessed using a dedicated command. The Extended Block can be protected and so is useful for storing security information. However the protection is irreversible, once protected the protection cannot be undone.

Each block can be erased independently, so it is possible to preserve valid data while old data is erased.

The device features four different levels of hardware and software block protection to avoid unwanted program or erase (modify). The software block protection features are available in 16 bit memory organization only:

- Hardware Protection:
 - The V_{PP}/\overline{WP} provides a hardware protection of the four outermost parameter blocks (two at the top and two at the bottom of the address space).
 - The \overline{RP} pin temporarily unprotects all the blocks previously protected using a High Voltage Block Protection technique (see *Appendix D: High Voltage Block Protection*).
- Software Protection
 - Standard Protection
 - Password Protection

The memory is offered in TSOP56 (14 x 20mm) and TBGA64 (10 x 13mm, 1mm pitch) packages. The 8-bit Bus mode is only available when the M29DW128F is delivered in TSOP56 package. In order to meet environmental requirements, Numonyx offers the M29DW128F in ECOPACK® packages. ECOPACK packages are Lead-free. The category of second Level Interconnect is marked on the package and on the inner box label, in compliance with JEDEC Standard JESD97. The maximum ratings related to soldering conditions are also marked on the inner box label. The memory is supplied with all the bits erased (set to '1').

Table 1. Signal names

A0-A22	Address Inputs
DQ0-DQ7	Data Inputs/Outputs
DQ8-DQ14	Data Inputs/Outputs
DQ15A-1	Data Input/Output or Address Input
\bar{E}	Chip Enable
\bar{G}	Output Enable
\bar{W}	Write Enable
$\bar{R}\bar{P}$	Reset/Block Temporary Unprotect
$\bar{R}\bar{B}$	Ready/Busy Output
$\bar{B}\bar{Y}\bar{T}\bar{E}$	Byte/Word Organization Select ⁽¹⁾
V _{CC}	Supply voltage
V _{PP} / $\bar{W}\bar{P}$	V _{PP} /Write Protect
V _{SS}	Ground
NC	Not Connected Internally

1. The x8 organization is only available in TSOP56 Package while the x16 organization is available for both packages.

Figure 1. Logic diagram

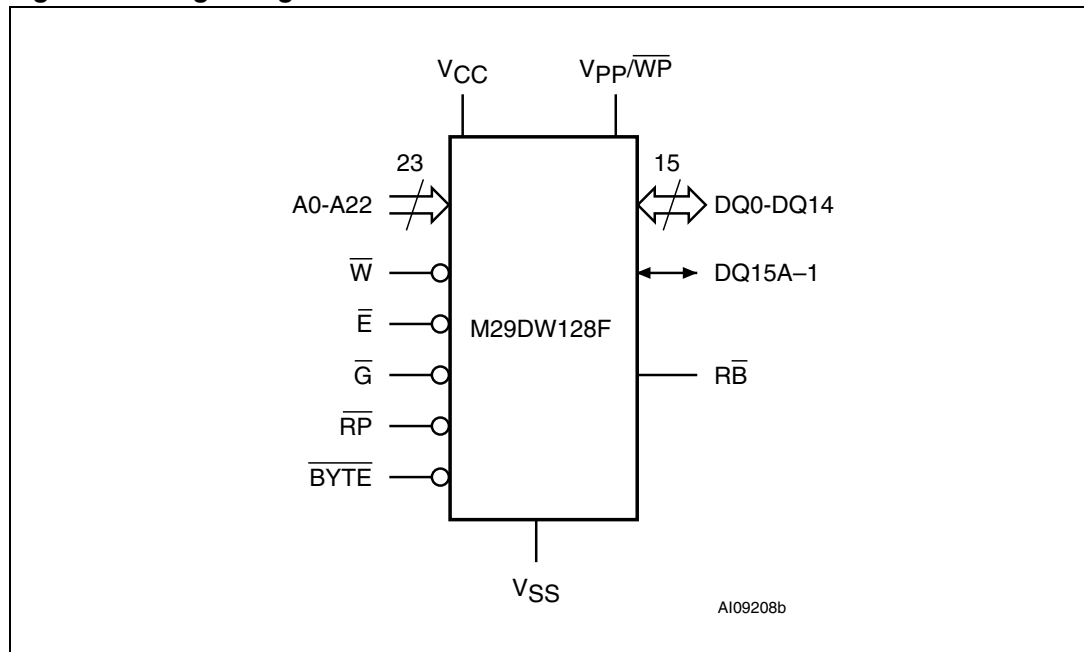

Table 2. Bank architecture

Bank	Bank size	Parameter Blocks		Main Blocks	
		No. of Blocks	Block size	No. of Blocks	Block size
A	16 Mbit	8	8 Kbytes/ 4 KWords	31	64 Kbytes/ 32 KWords
B	48 Mbit	—	—	96	64 Kbytes/ 32 KWords
C	48 Mbit	—	—	96	64 Kbytes/ 32 KWords
D	16 Mbit	8	8 Kbytes/ 4 KWords	31	64 Kbytes/ 32 KWords

Figure 2. TSOP connections

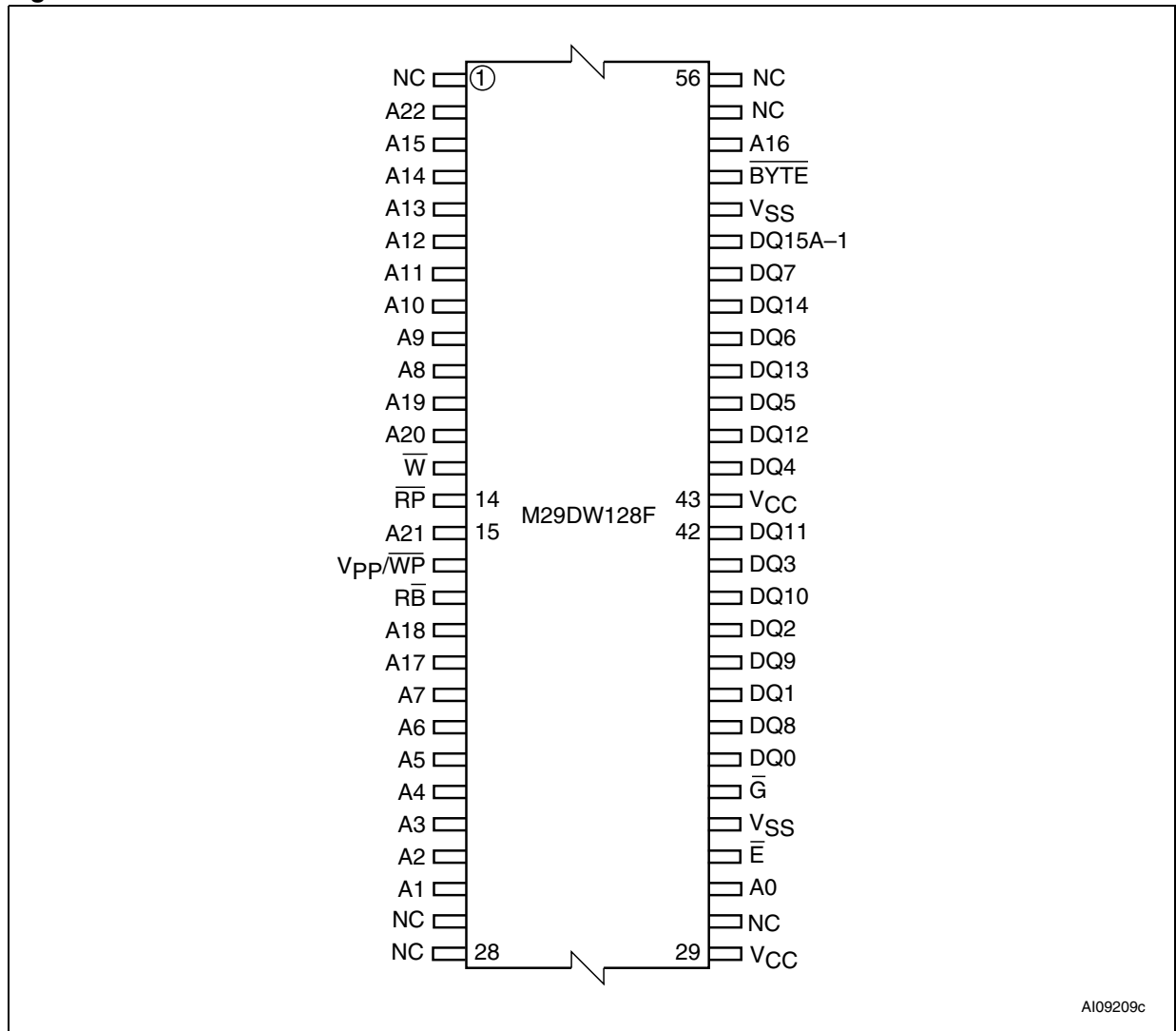

Figure 3. TBGA connections (top view through package)

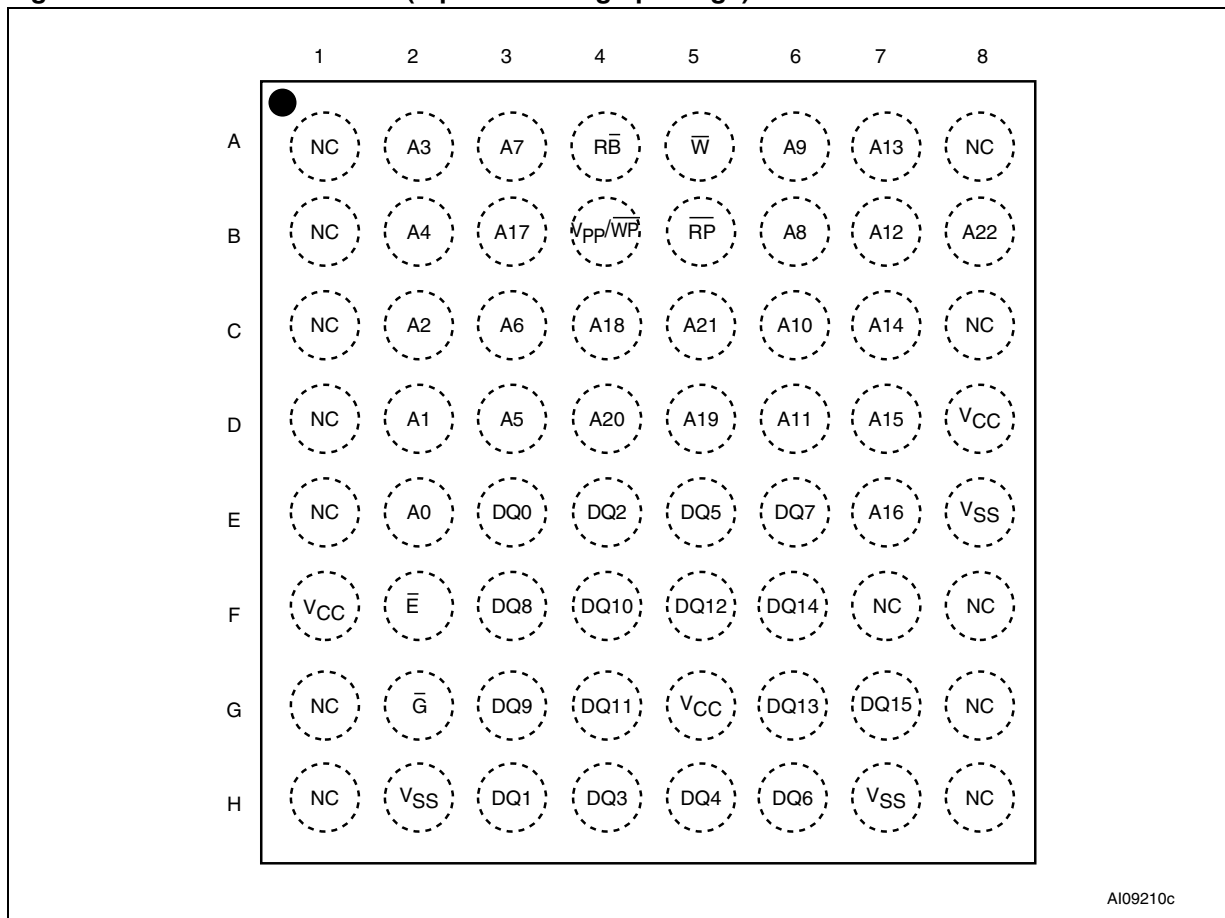
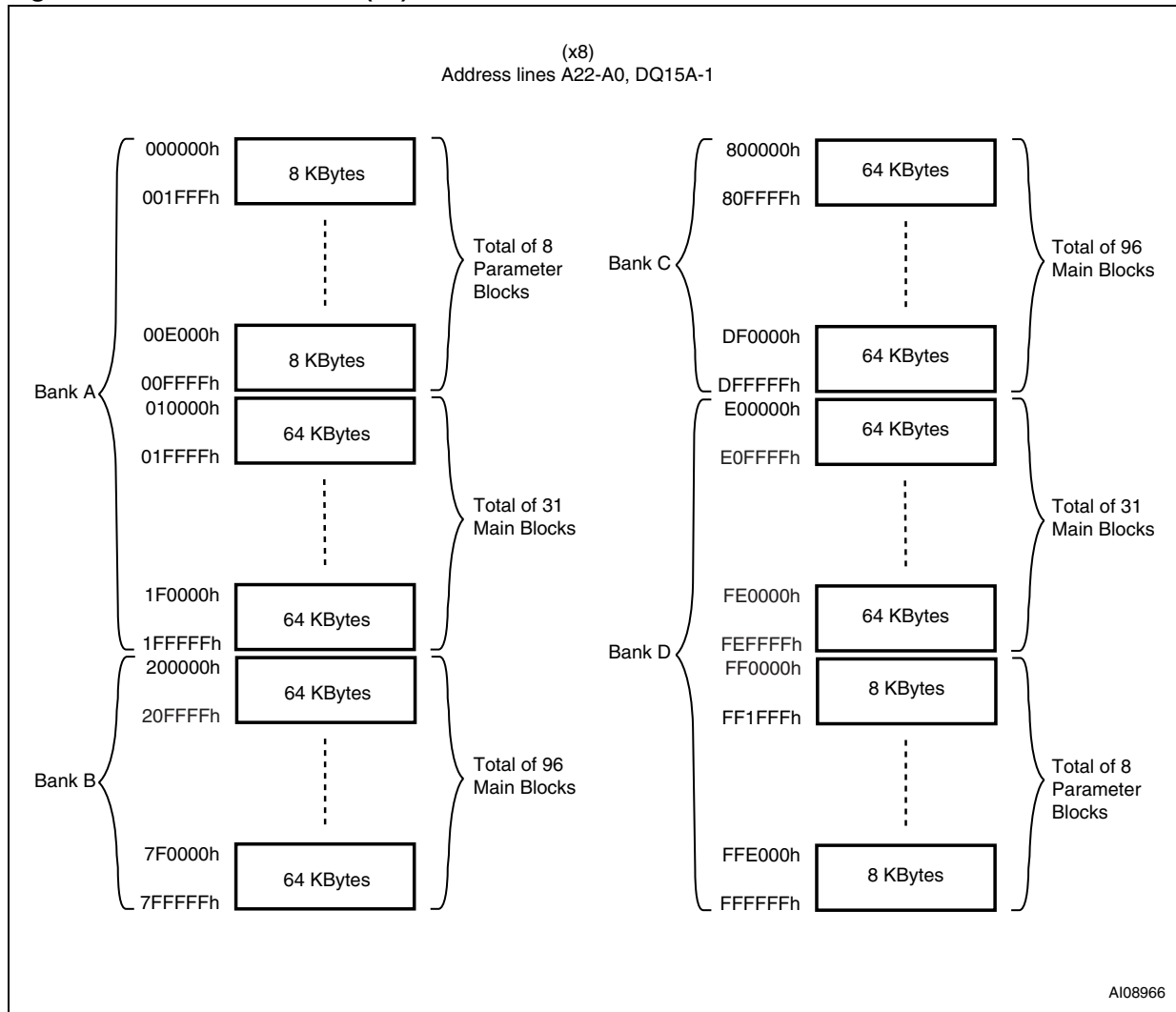
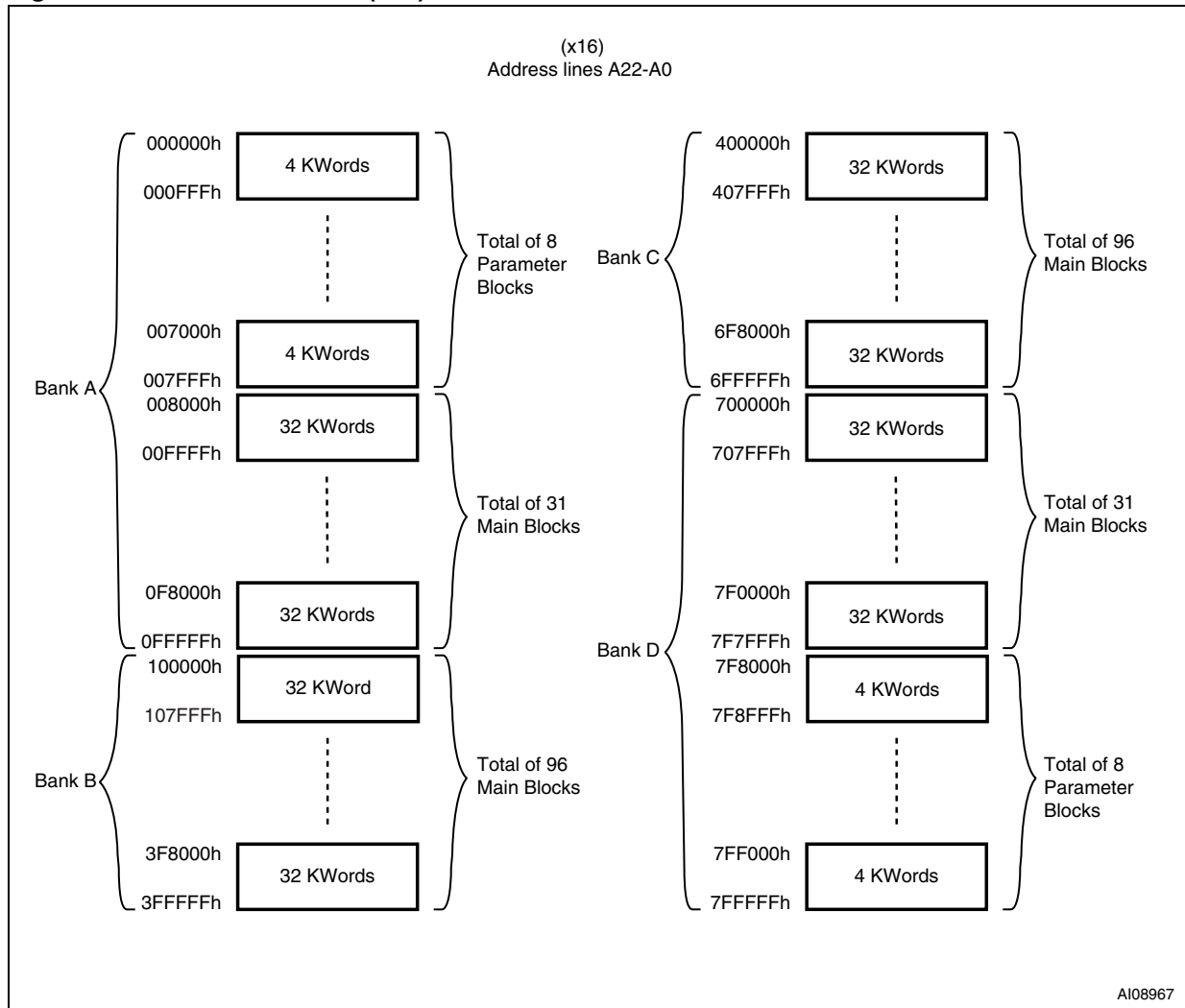

Figure 4. Block Addresses (x8)



1. Also see *Appendix A* and *Table 34* for a full listing of the Block Addresses.

Figure 5. Block Addresses (x16)



1. Also see Appendix A, Table 34 for a full listing of the Block Addresses.

2 Signal descriptions

See *Figure 1: Logic diagram*, and *Table 1: Signal names*, for a brief overview of the signals connected to this device.

2.1 Address Inputs (A0-A22)

The Address Inputs select the cells in the memory array to access during Bus Read operations. During Bus Write operations they control the commands sent to the Command Interface of the Program/Erase Controller.

2.2 Data Inputs/Outputs (DQ0-DQ7)

The Data I/O outputs the data stored at the selected address during a Bus Read operation. During Bus Write operations they represent the commands sent to the Command Interface of the internal state machine.

2.3 Data Inputs/Outputs (DQ8-DQ14)

The Data I/O outputs the data stored at the selected address during a Bus Read operation when $\overline{\text{BYTE}}$ is High, V_{IH} . When $\overline{\text{BYTE}}$ is Low, V_{IL} , these pins are not used and are high impedance. During Bus Write operations the Command Register does not use these bits. When reading the Status Register these bits should be ignored.

2.4 Data Input/Output or Address Input (DQ15A-1)

When the device is in x16 Bus mode, this pin behaves as a Data Input/Output pin (as DQ8-DQ14). When the device is in x8 Bus mode, this pin behaves as an address pin; DQ15A-1 Low will select the LSB of the addressed Word, DQ15A-1 High will select the MSB. Throughout the text consider references to the Data Input/Output to include this pin when the device operates in x16 bus mode and references to the Address Inputs to include this pin when the device operates in x8 bus mode except when stated explicitly otherwise.

2.5 Chip Enable ($\overline{\text{E}}$)

The Chip Enable pin, $\overline{\text{E}}$, activates the memory, allowing Bus Read and Bus Write operations to be performed. When Chip Enable is High, V_{IH} , all other pins are ignored.

2.6 Output Enable ($\overline{\text{G}}$)

The Output Enable pin, $\overline{\text{G}}$, controls the Bus Read operation of the memory.

2.7 Write Enable (\overline{W})

The Write Enable pin, \overline{W} , controls the Bus Write operation of the memory's Command Interface.

2.8 $V_{PP}/$ Write Protect (V_{PP}/\overline{WP})

The $V_{PP}/$ Write Protect pin provides two functions. The V_{PP} function allows the memory to use an external high voltage power supply to reduce the time required for Program operations. This is achieved by bypassing the unlock cycles and/or using the multiple Word (2 or 4 at-a-time) or multiple byte Program (2, 4 or 8 at-a-time) commands.

The Write Protect function provides a hardware method of protecting the four outermost boot blocks (two at the top, and two at the bottom of the address space). When $V_{PP}/$ Write Protect is Low, V_{IL} , the memory protects the four outermost boot blocks; Program and Erase operations in these blocks are ignored while $V_{PP}/$ Write Protect is Low, even when \overline{RP} is at V_{ID} .

When $V_{PP}/$ Write Protect is High, V_{IH} , the memory reverts to the previous protection status of the four outermost boot blocks. Program and Erase operations can now modify the data in these blocks unless the blocks are protected using Block Protection.

Applying V_{PPH} to the V_{PP}/\overline{WP} pin will temporarily unprotect any block previously protected (including the four outermost parameter blocks) using a High Voltage Block Protection technique (In-System or Programmer technique). See *Table 9: Hardware Protection* for details.

When $V_{PP}/$ Write Protect is raised to V_{PP} the memory automatically enters the Unlock Bypass mode. When $V_{PP}/$ Write Protect returns to V_{IH} or V_{IL} normal operation resumes. During Unlock Bypass Program operations the memory draws I_{PP} from the pin to supply the programming circuits. See the description of the Unlock Bypass command in the Command Interface section. The transitions from V_{IH} to V_{PP} and from V_{PP} to V_{IH} must be slower than t_{VHVPP} see *Figure 20*.

Never raise $V_{PP}/$ Write Protect to V_{PP} from any mode except Read mode, otherwise the memory may be left in an indeterminate state.

The $V_{PP}/$ Write Protect pin must not be left floating or unconnected or the device may become unreliable. A 0.1 μ F capacitor should be connected between the $V_{PP}/$ Write Protect pin and the V_{SS} Ground pin to decouple the current surges from the power supply. The PCB track widths must be sufficient to carry the currents required during Unlock Bypass Program, I_{PP}

2.9 Reset/Block Temporary Unprotect ($\overline{\text{RP}}$)

The Reset/Block Temporary Unprotect pin can be used to apply a Hardware Reset to the memory or to temporarily unprotect all the blocks previously protected using a High Voltage Block Protection technique (In-System or Programmer technique).

Note that if $V_{\text{PP}}/\overline{\text{WP}}$ is at V_{IL} , then the four outermost parameter blocks will remain protected even if $\overline{\text{RP}}$ is at V_{ID} .

A Hardware Reset is achieved by holding Reset/Block Temporary Unprotect Low, V_{IL} , for at least t_{PLPX} . After Reset/Block Temporary Unprotect goes High, V_{IH} , the memory will be ready for Bus Read and Bus Write operations after t_{PHEL} or t_{RHEL} , whichever occurs last. See the Ready/Busy Output section, *Table 30: Reset/Block Temporary Unprotect AC characteristics* and *Figure 18* and *Figure 19* for more details.

Holding $\overline{\text{RP}}$ at V_{ID} will temporarily unprotect all the blocks previously protected using a High Voltage Block Protection technique. Program and erase operations on all blocks will be possible. The transition from V_{IH} to V_{ID} must be slower than t_{PHPHH} .

2.10 Ready/Busy Output ($\overline{\text{RB}}$)

The Ready/Busy pin is an open-drain output that can be used to identify when the device is performing a Program or erase operation. During Program or erase operations Ready/Busy is Low, V_{OL} . Ready/Busy is high-impedance during Read mode, Auto Select mode and Erase Suspend mode.

After a Hardware Reset, Bus Read and Bus Write operations cannot begin until Ready/Busy becomes high-impedance. See *Table 30: Reset/Block Temporary Unprotect AC characteristics* and *Figure 18* and *Figure 19*.

The use of an open-drain output allows the Ready/Busy pins from several memories to be connected to a single pull-up resistor. A Low will then indicate that one, or more, of the memories is busy.

2.11 Byte/Word Organization Select ($\overline{\text{BYTE}}$)

It is used to switch between the x8 and x16 Bus modes of the memory when the M29DW128F is delivered in TSOP56 package. When Byte/Word Organization Select is Low, V_{IL} , the memory is in x8 mode, when it is High, V_{IH} , the memory is in x16 mode.

2.12 V_{CC} supply voltage (2.7V to 3.6V)

V_{CC} provides the power supply for all operations (Read, Program and Erase).

The Command Interface is disabled when the V_{CC} Supply Voltage is less than the Lockout Voltage, V_{LKO} . This prevents Bus Write operations from accidentally damaging the data during power up, power down and power surges. If the Program/Erase Controller is programming or erasing during this time then the operation aborts and the memory contents being altered will be invalid.

A 0.1 μ F capacitor should be connected between the V_{CC} Supply Voltage pin and the V_{SS} Ground pin to decouple the current surges from the power supply. The PCB track widths must be sufficient to carry the currents required during Program and erase operations, I_{CC2} .

2.13 V_{SS} Ground

V_{SS} is the reference for all voltage measurements. The device features two V_{SS} pins both of which must be connected to the system ground.

3 Bus operations

There are five standard bus operations that control the device. These are Bus Read (Random and Page modes), Bus Write, Output Disable, Standby and Automatic Standby.

Dual operations are possible in the M29DW128F, thanks to its multiple bank architecture. While programming or erasing in one banks, read operations are possible in any of the other banks. Write operations are only allowed in one bank at a time.

See *Table 3* and *Table 6*, Bus Operations, for a summary. Typically glitches of less than 5ns on Chip Enable, Write Enable, and Reset/Block Temporary Unprotect pins are ignored by the memory and do not affect bus operations.

3.1 Bus Read

Bus Read operations read from the memory cells, or specific registers in the Command Interface. To speed up the read operation the memory array can be read in Page mode where data is internally read and stored in a page buffer. The Page has a size of 8 Words and is addressed by the address inputs A0-A2.

A valid Bus Read operation involves setting the desired address on the Address Inputs, applying a Low signal, V_{IL} , to Chip Enable and Output Enable and keeping Write Enable High, V_{IH} . The Data Inputs/Outputs will output the value, see *Figure 12: Random Read AC waveforms*, *Figure 13: Page Read AC waveforms*, and *Table 26: Read AC characteristics*, for details of when the output becomes valid.

3.2 Bus Write

Bus Write operations write to the Command Interface. A valid Bus Write operation begins by setting the desired address on the Address Inputs. The Address Inputs are latched by the Command Interface on the falling edge of Chip Enable or Write Enable, whichever occurs last. The Data Inputs/Outputs are latched by the Command Interface on the rising edge of Chip Enable or Write Enable, whichever occurs first. Output Enable must remain High, V_{IH} , during the whole Bus Write operation. See *Figure 14* and *Figure 15*, Write AC Waveforms, and *Table 27* and *Table 28*, Write AC Characteristics, for details of the timing requirements.

3.3 Output Disable

The Data Inputs/Outputs are in the high impedance state when Output Enable is High, V_{IH} .

3.4 Standby

When Chip Enable is High, V_{IH} , the memory enters Standby mode and the Data Inputs/Outputs pins are placed in the high-impedance state. To reduce the Supply Current to the Standby Supply Current, I_{CC2} , Chip Enable should be held within $V_{CC} \pm 0.2V$. For the Standby current level see *Table 25: DC Characteristics*. During program or erase operations the memory will continue to use the Program/Erase Supply Current, I_{CC3} , for Program or Erase operations until the operation completes.

3.5 Automatic Standby

If CMOS levels ($V_{CC} \pm 0.2V$) are used to drive the bus and the bus is inactive for 300ns or more the memory enters Automatic Standby where the internal Supply Current is reduced to the Standby Supply Current, I_{CC2} . The Data Inputs/Outputs will still output data if a Bus Read operation is in progress.

3.6 Special Bus operations

Additional bus operations can be performed to read the Electronic Signature, verify the Protection Status of the Extended Memory Block (second section), and apply and remove Block Protection. These bus operations are intended for use by programming equipment and are not usually used in applications. They require V_{ID} to be applied to some pins.

3.6.1 Read Electronic Signature

The memory has two codes, the Manufacturer code and the Device code used to identify the memory. These codes can be accessed by performing read operations with control signals and addresses set as shown in *Table 4* and *Table 6*. These codes can also be accessed by issuing an Auto Select command (see *Section 6.1.2: Auto Select command*).

3.6.2 Verify Extended Block Protection Indicator

The Extended Block is divided in two sections of which one is Factory Locked and the second one is either Customer Lockable or Customer Locked.

The Protection Status of the second section of the Extended Block (Customer Lockable or Customer Locked) can be accessed by reading the Extended Block Protection Indicator. This is performed by applying the signals as shown in *Table 5* and *Table 8*. The Protection Status of the Extended Block is then output on bits DQ7 and DQ6 of the Data Input/Outputs. (see *Table 3* and *Table 6*, Bus Operations).

The Protection Status of the Extended Block can also be accessed by issuing an Auto Select command (see *Section 6.1.2: Auto Select command*).

3.6.3 Verify Block Protection Status

The Protection Status of a Block can be directly accessed by performing a read operation with control signals and addresses set as shown in *Table 5* and *Table 8*. If the Block is protected, then 01h (in x8 mode) is output on Data Input/Outputs DQ0-DQ7, otherwise 00h is output.

3.6.4 Hardware Block Protect

The V_{PP}/\overline{WP} pin can be used to protect the four outermost parameter blocks. When V_{PP}/\overline{WP} is at V_{IL} the four outermost parameter blocks are protected and remain protected regardless of the Block Protection Status or the Reset/Block Temporary Unprotect pin state.

3.6.5 Temporary Unprotect of high voltage Protected Blocks

The \overline{RP} pin can be used to temporarily unprotect all the blocks previously protected using the In-System or the Programmer protection technique (High Voltage techniques). Refer to *Section 2.9: Reset/Block Temporary Unprotect (RP)*.

Table 3. Bus operations, 8-bit mode⁽¹⁾

Operation	\overline{E}	\overline{G}	\overline{W}	\overline{RP}	V_{PP}/\overline{WP}	Address Inputs					Data Inputs/Outputs	
						A22-A0, DQ15A-1					DQ14-DQ8	DQ7-DQ0
Bus Read	V_{IL}	V_{IL}	V_{IH}	V_{IH}	V_{IH}	Cell Address					Hi-Z	Data Output
Bus Write	V_{IL}	V_{IH}	V_{IL}	V_{IH}	V_{IH}	Command Address					Hi-Z	Data Input
Output Disable	X	V_{IH}	V_{IH}	V_{IH}	V_{IH}	X					Hi-Z	Hi-Z
Standby	V_{IH}	X	X	V_{IH}	V_{IH}	X					Hi-Z	Hi-Z

1. X = V_{IL} or V_{IH} .

Table 4. Read Electronic Signature, 8-bit mode⁽¹⁾

Read Cycle	\overline{E}	\overline{G}	\overline{W}	Address Inputs											Data Inputs/Outputs	
				A22-A10	A9	A8	A7-A6	A5-A4	A3	A2	A1	A0	DQ15A-1	DQ14-DQ8	DQ7-DQ0	
Manufacturer Code	V_{IL}	V_{IL}	V_{IH}	X	V_{ID}	X	V_{IL}	X	V_{IL}	V_{IL}	V_{IL}	V_{IL}	X	Hi-Z	20h	
Device Code (Cycle 1)								V_{IL}	V_{IL}	V_{IL}	V_{IH}	X	Hi-Z	7Eh		
Device Code (Cycle 2)								V_{IH}	V_{IH}	V_{IH}	V_{IL}	X	Hi-Z	20h		
Device Code (Cycle 3)								V_{IH}	V_{IH}	V_{IH}	V_{IH}	X	Hi-Z	00h		

1. X = V_{IL} or V_{IH} .

Table 5. Block Protection, 8-bit mode⁽¹⁾

Operation	\overline{E}	\overline{G}	\overline{W}	\overline{RP}	V_{PP}/\overline{WP}	Address Inputs											Data Inputs/Outputs	
						A22-A12	A11-A10	A9	A8	A7	A6	A5-A4	A3-A2	A1	A0	DQ15A-1	DQ14-DQ8	DQ7-DQ0
Verify Extended Block Protection Indicator (bits DQ6, DQ7)	V_{IL}	V_{IL}	V_{IH}	V_{IH}	V_{IH}	BA	X	V_{ID}	X	X	V_{IL}	X	V_{IL}	V_{IH}	V_{IH}	X	Hi-Z	80h (Customer Lockable) C0h (Customer Locked) ⁽²⁾
Verify Block Protection Status						BKA												V_{IL}
Temporary Block Unprotect ⁽³⁾	X	X	X	V_{ID}	X	Valid												Data Input

1. X = V_{IL} or V_{IH} . BKA Bank Address, BA any Address in the Block.
2. This indicates the protection status of the second section of the Extended Block; the first section of the Extended Block being always Factory Locked.
3. The \overline{RP} pin unprotects all the blocks that have been previously protected using a High Voltage protection Technique.

Table 6. Bus operations, 16-bit mode⁽¹⁾

Operation	\bar{E}	\bar{G}	\bar{W}	\bar{RP}	V_{PP}/WP	Address Inputs	Data Inputs/Outputs
						A22-A0	DQ15A-1, DQ14-DQ0
Bus Read	V_{IL}	V_{IL}	V_{IH}	V_{IH}	V_{IH}	Cell Address	Data Output
Bus Write	V_{IL}	V_{IH}	V_{IL}	V_{IH}	V_{IH}	Command Address	Data Input
Output Disable	X	V_{IH}	V_{IH}	V_{IH}	V_{IH}	X	Hi-Z
Standby	V_{IH}	X	X	V_{IH}	V_{IH}	X	Hi-Z

1. X = V_{IL} or V_{IH} .

Table 7. Read Electronic Signature, 16-bit mode⁽¹⁾

Read Cycle	\bar{E}	\bar{G}	\bar{W}	Address Inputs										Data Inputs/Outputs
				A22-A10	A9	A8	A7-A6	A5-A4	A3	A2	A1	A0	DQ15A-1, DQ14-DQ0	
Manufacturer Code	V_{IL}	V_{IL}	V_{IH}	X	V_{ID}	X	V_{IL}	X	V_{IL}	V_{IL}	V_{IL}	V_{IL}	0020h	
Device Code (Cycle 1)								V_{IL}	V_{IL}	V_{IL}	V_{IL}	V_{IH}	227Eh	
Device Code (Cycle 2)									V_{IH}	V_{IH}	V_{IH}	V_{IL}	2220h	
Device Code (Cycle 3)									V_{IH}	V_{IH}	V_{IH}	V_{IH}	2200h	

1. X = V_{IL} or V_{IH} .

Table 8. Block Protection, 16-bit mode⁽¹⁾

Operation	\bar{E}	\bar{g}	\bar{W}	\bar{RP}	V_{PP}/WP	Address Inputs										Data Inputs/Outputs
						A22-A12	A11-A10	A9	A8	A7	A6	A5-A4	A3-A2	A1	A0	DQ15A-1, DQ14-DQ0
Verify Extended Block Indicator (bits DQ6, DQ7)	V_{IL}	V_{IL}	V_{IH}	V_{IH}	V_{IH}	BA	X	V_{ID}	X	X	V_{IL}	X	V_{IL}	V_{IH}	V_{IH}	0080h (Customer Lockable) 00C0h (Customer Locked) ⁽²⁾
Verify Block Protection Status																BKA
Temporary Block Unprotect ⁽³⁾	X	X	X	V_{ID}	X	Valid										Data Input

1. X = V_{IL} or V_{IH} . BKA Bank Address, BA Any Address in the Block.

2. This indicates the protection status of the second section of the Extended Block; the first section of the Extended Block being always Factory Locked.

3. The \bar{RP} pin unprotects all the blocks that have been previously protected using a High Voltage protection Technique.

4 Hardware Protection

The M29DW128F features hardware protection/unprotection. Refer to *Table 9* for details on hardware block protection/unprotection using V_{PP}/\overline{WP} and \overline{RP} pins.

4.1 Write Protect

The V_{PP}/\overline{WP} pin protects the four outermost parameter blocks (refer to *Section 2: Signal descriptions* for a detailed description of the signals).

4.2 Temporary Block Unprotect

When held at V_{ID} , the Reset/Block Temporary Unprotect pin, \overline{RP} , will temporarily unprotect all the blocks previously protected using a High Voltage Block Protection technique.

Table 9. Hardware Protection

V_{PP}/\overline{WP}	\overline{RP}	Function
V_{IL}	V_{IH}	4 outermost parameter blocks protected from Program/Erase operations
	V_{ID}	All blocks temporarily unprotected except the 4 outermost blocks ⁽¹⁾
V_{IH} or V_{ID}	V_{ID}	All blocks temporarily unprotected ⁽¹⁾
V_{PPH}	V_{IH} or V_{ID}	All blocks temporarily unprotected ⁽¹⁾

1. The temporary unprotection is valid only for the blocks that have been protected using the High Voltage Protection Technique (see *Appendix D: High Voltage Block Protection*). The blocks protected using a software protection method (Standard, Password) do not follow this rules.

5 Software Protection

The M29DW128F has two different Software Protection modes: the Standard Protection mode and the Password Protection mode.

On first use all parts default to the Standard Protection mode and the customer is free to activate the Standard or the Password Protection mode.

The desired protection mode is activated by setting one of two one-time programmable bits, the Standard Protection Mode Lock bit or the Password Protection Mode Lock bit. Programming the Standard and the Password Protection Mode Lock bit to '1' will permanently activate the Standard Protection mode and the Password Protection mode, respectively. These two bits are one-time programmable and non-volatile, once the Protection mode has been programmed, it cannot be changed and the device will permanently operate in the selected Protection mode. It is recommended to activate the desired Software Protection mode when first programming the device.

The device is shipped with all blocks unprotected. The Block Protection Status can be read by issuing the Auto Select command (see *Table 10: Block Protection status*).

The Standard and Password Protection modes offer two levels of protection, a Block Lock/Unlock protection and a Non-Volatile protection.

For the four outermost parameter blocks, an even higher level of block protection can be achieved by locking the blocks using the Non-Volatile Protection and then by holding the V_{PP}/\overline{WP} pin Low.

5.1 Standard Protection mode

5.1.1 Block Lock/Unlock Protection

It is a flexible mechanism to protect/unprotect a block or a group of blocks from program or erase operations.

A volatile Lock bit is assigned to each block or group of blocks. When the lock bit is set to '1' the associated block or group of blocks is protected from program/erase operations, when the Lock bit is set to '0' the associated block or group of blocks is unprotected and can be programmed or erased.

The Lock bits can be set ('1') and cleared ('0') individually as often as required by issuing a Set Lock Bit command and Clear Lock bit command, respectively.

After a Power-up or Hardware Reset, all the Lock bits are cleared to '0' (block unlocked).

5.1.2 Non-Volatile Protection

A Non-Volatile Modify Protection bit is assigned to each block or group of blocks.

When a Non-Volatile Modify Protection bit is set to '1' the associated block or group of blocks is protected, preventing any program or erase operations in this block or group of blocks.

The Non-Volatile Modify Protection bits are set individually by issuing a Set Non-Volatile Modify Protection bit command. They are non-volatile and will remain set through a hardware reset or a power-down/power-up sequence.

The Non-Volatile Modify Protection bits cannot be cleared individually, they can only be cleared all at the same time by issuing a Clear Non-Volatile Modify Protection bits command.

However if any one of the Non-Volatile Modify Protection bits has to be cleared, care should be taken to preprogram to '1' all the Non-Volatile Modify Protection bits prior to issuing the Clear Non-Volatile Modify Protection bits in order to prevent the over-erasure of previously cleared Non Volatile Modify Protection bits. It is crucial to prevent over-erasure because the process may lead to permanent damage to the Non-Volatile Modify Protection bits and the device does not have any built-in means of preventing over-erasure.

The device features a volatile Lock-Down bit which can be used to prevent changing the state of the Non-Volatile Modify Protection bits. When set to '1', the Non-Volatile Modify Protection bits can no longer be modified; when set to '0', the Non-Volatile Modify Protection bits can be set and reset using the Set Non-Volatile Modify Protection bit command and the Clear Non-Volatile Modify Protection bits command, respectively.

The Lock-Down bit is set by issuing the Set Lock-Down bit Command. It is not cleared using a command, but through a hardware reset or a power-down/power-up sequence.

The parts are shipped with the Non-Volatile Modify Protection bits set to '0'.

Locked blocks and Non-Volatile Locked blocks can co-exist in the same memory array.

Refer to *Table 10: Block Protection status* and *Figure 7: Software Protection scheme* for details on the block protection mechanism.

5.2 Password Protection mode

The Password Protection mode provides a more advanced level of software protection than the Standard Protection mode.

Prior to entering the Password Protection mode, it is necessary to set a password and to verify it (see *Section 6.3.5: Password Program command* and *Section 6.3.6: Password Verify command*). The Password Protection mode is then activated by programming the Password Protection Mode Lock bit to '1'. The Reset/Block Temporary Unprotect pin, \overline{RP} , can be at V_{ID} or at V_{IH} .

This operation is not reversible and once the bit is programmed the device will permanently remain in the Password Protection mode.

The Password Protection mode uses the same protection mechanisms as the Standard Protection mode (Block Lock/Unlock, Non-Volatile Protection).

5.2.1 Block Lock/Unlock Protection

The Block Lock/Unlock Protection operates exactly in the same way as in the Standard Protection mode.

5.2.2 Non-Volatile Protection

The Non-Volatile Protection is more advanced in the Password Protection mode.

In this mode, the Lock-Down bit cannot be cleared through a hardware reset or a power-down/power-up sequence.

The Lock-Down bit is cleared by issuing the Password Protection Unlock command along with the correct password.

Once the correct Password has been provided, the Lock-Down bit is cleared and the Non-Volatile Modify Protection bits can be set or reset using the appropriate commands (the Set Non-Volatile Modify Protection bit command or the Clear Non-Volatile Modify Protection bits command, respectively).

If the Password provided is not correct, the Lock-Down bit remains locked and the state of the Non-Volatile Modify Protection bits cannot be modified.

The Password is a 64-bit code located in the memory space. It must be programmed by the user prior to selecting the Password Protection mode. The Password is programmed by issuing a Password Program command and checked by issuing a Password Verify command. The Password should be unique for each part.

Once the device is in Password Protection mode, the Password can no longer be read or retrieved. Moreover, all commands to the address where the password is stored, are disabled. Refer to *Table 10: Block Protection status* and *Figure 7: Software Protection scheme* for details on the block protection scheme.

Table 10. Block Protection status

Volatile Lock bit	Non-Volatile Modify Protection bit	Lock-Down bit	Block Protection status	Block Protection status	
0	0	0	00h	Block Unprotected	Non-Volatile Modify Protection bit can be modified ⁽¹⁾
0	0	1			Non-Volatile Modify Protection bit cannot be modified ⁽¹⁾
0	1	0	01h	Block Program/ Erase Protected	Non-Volatile Modify Protection bit can be modified ⁽¹⁾
1	0	0			
1	1	0			
0	1	1			Non-Volatile Modify Protection bit cannot be modified ⁽¹⁾
1	0	1			
1	1	1			

1. The Lock bit can always be modified by issuing a Clear Lock bit command or by taking the device through a Power-up or Hardware Reset.

Figure 6. Block Protection State diagram

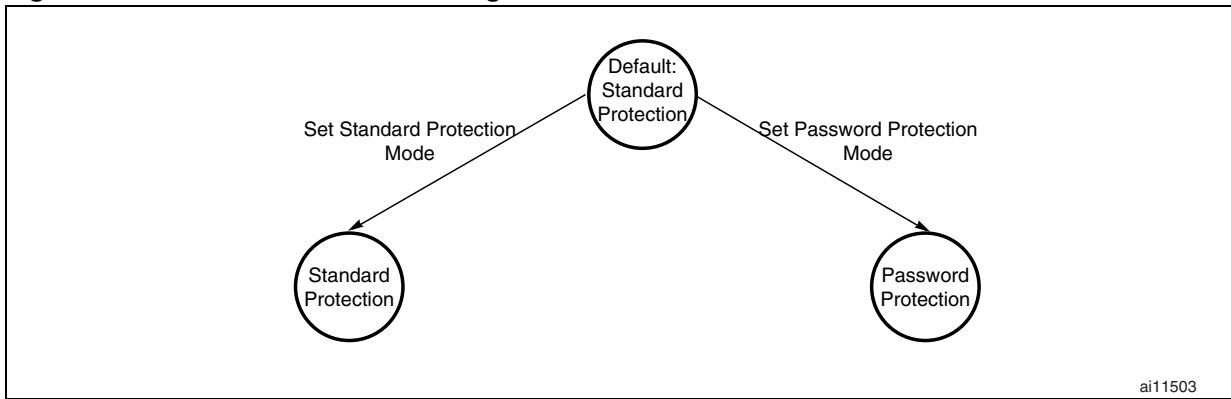
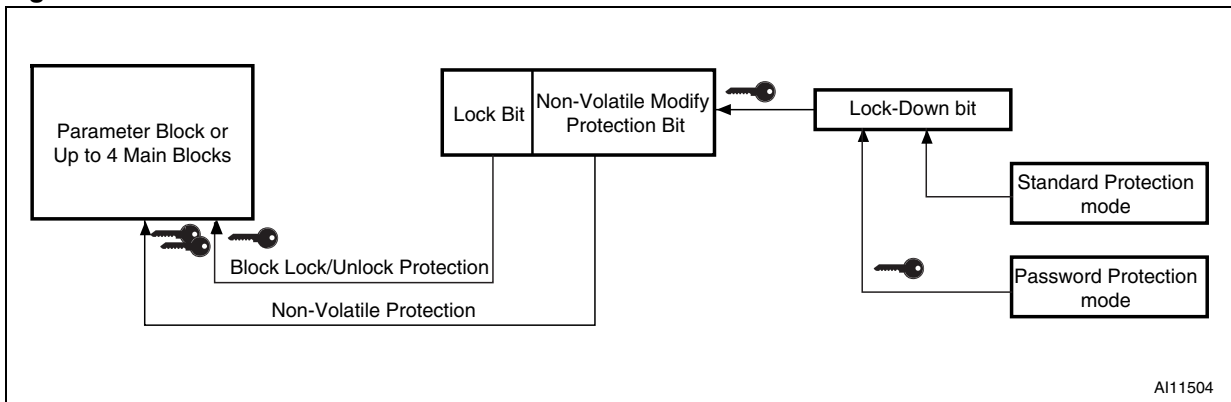

Figure 7. Software Protection scheme



6 Command interface

All Bus Write operations to the memory are interpreted by the Command Interface. Commands consist of one or more sequential Bus Write operations. Failure to observe a valid sequence of Bus Write operations will result in the memory returning to Read mode. The long command sequences are imposed to maximize data security.

The address used for the commands changes depending on whether the memory is in 16-bit or 8-bit mode.

6.1 Standard commands

See either *Table 12*, or *Table 11*, depending on the configuration that is being used, for a summary of the Standard commands.

6.1.1 Read/Reset command

The Read/Reset command returns the memory to Read mode. It also resets the errors in the Status Register. Either one or three Bus Write operations can be used to issue the Read/Reset command.

The Read/Reset command can be issued, between Bus Write cycles before the start of a program or erase operation, to return the device to Read mode. If the Read/Reset command is issued during the time-out of a Block erase operation, the memory will take up to 10 μ s to abort. During the abort period no valid data can be read from the memory.

The Read/Reset command will not abort an Erase operation when issued while in Erase Suspend.

6.1.2 Auto Select command

The Auto Select command is used to read the Manufacturer Code, the Device Code, the Protection Status of each block (Block Protection Status) and the Extended Block Protection Indicator. It can be addressed to either Bank.

Three consecutive Bus Write operations are required to issue the Auto Select command. Once the Auto Select command is issued Bus Read operations to specific addresses output the Manufacturer Code, the Device Code, the Extended Block Protection Indicator and a Block Protection Status (see *Table 11* and *Table 12* in conjunction with *Table 4*, *Table 5*, *Table 7* and *Table 8*). The memory remains in Auto Select mode until a Read/Reset or CFI Query command is issued.

6.1.3 Read CFI Query command

The Read CFI Query Command is used to put the addressed bank in Read CFI Query mode. Once in Read CFI Query mode Bus Read operations to the same bank will output data from the Common Flash Interface (CFI) Memory Area. If the read operations are to a different bank from the one specified in the command then the read operations will output the contents of the memory array and not the CFI data.

One Bus Write cycle is required to issue the Read CFI Query Command. Care must be taken to issue the command to one of the banks (A22-A19) along with the address shown in *Table 3* and *Table 6*. Once the command is issued subsequent Bus Read operations in the same bank (A22-A19) to the addresses shown in *Appendix B: Common Flash Interface (CFI) (A7-A0)*, will read from the Common Flash Interface Memory Area.

This command is valid only when the device is in the Read Array or Auto Select mode. To enter Read CFI query mode from Auto Select mode, the Read CFI Query command must be issued to the same bank address as the Auto Select command, otherwise the device will not enter Read CFI Query mode.

The Read/Reset command must be issued to return the device to the previous mode (the Read Array mode or Auto Select mode). A second Read/Reset command is required to put the device in Read Array mode from Auto Select mode.

See *Appendix B, Table 35, Table 36, Table 37, Table 38, Table 39* and *Table 40* for details on the information contained in the Common Flash Interface (CFI) memory area.

6.1.4 Blank Verify command

The Blank Verify command is used to check if a block is blank or in other words, if it has been successfully erased and all its bits set to '1'. Three cycles are required to issue a Verify command:

1. The command starts with two unlock cycles.
2. The third bus write cycle sets up the Verify command code along with the address of the block to be checked.
3. Bus Read operations during the Blank Verify operation output the Status Register on Data Inputs/Outputs (see *7: Status Register*).

After the Blank Verify command has completed, the memory returns to Read mode, unless an error has occurred. When an error occurs, the memory continues to output the Status Register. A Read/Reset command must be issued to reset the error condition and return to Read mode.F

6.1.5 Chip Erase command

The Chip Erase command can be used to erase the entire chip. Six Bus Write operations are required to issue the Chip Erase Command and start the Program/Erase Controller.

If any blocks are protected, then these are ignored and all the other blocks are erased. If all of the blocks are protected the Chip Erase operation appears to start but will terminate within about 100µs, leaving the data unchanged. No error condition is given when protected blocks are ignored.

During the erase operation the memory will ignore all commands, including the Erase Suspend command. It is not possible to issue any command to abort the operation. Typical chip erase times are given in *Table 18*. All Bus Read operations during the Chip Erase

operation will output the Status Register on the Data Inputs/Outputs. See the section on the Status Register for more details.

After the Chip Erase operation has completed the memory will return to the Read mode, unless an error has occurred. When an error occurs the memory will continue to output the Status Register. A Read/Reset command must be issued to reset the error condition and return to Read mode.

The Chip Erase Command sets all of the bits in unprotected blocks of the memory to '1'. All previous data is lost.

6.1.6 Block Erase command

The Block Erase command can be used to erase a list of one or more blocks in one or more Banks. It sets all of the bits in the unprotected selected blocks to '1'. All previous data in the selected blocks is lost.

Six Bus Write operations are required to select the first block in the list. Each additional block in the list can be selected by repeating the sixth Bus Write operation using the address of the additional block. The Block Erase operation starts the Program/Erase Controller after a time-out period of 50 μ s after the last Bus Write operation. Once the Program/Erase Controller starts it is not possible to select any more blocks. Each additional block must therefore be selected within 50 μ s of the last block. The 50 μ s timer restarts when an additional block is selected. After the sixth Bus Write operation a Bus Read operation within the same Bank will output the Status Register. See the Status Register section for details on how to identify if the Program/Erase Controller has started the Block Erase operation.

If any selected blocks are protected then these are ignored and all the other selected blocks are erased. If all of the selected blocks are protected the Block Erase operation appears to start but will terminate within about 100 μ s, leaving the data unchanged. No error condition is given when protected blocks are ignored.

During the Block Erase operation the memory will ignore all commands except the Erase Suspend command and the Read/Reset command which is only accepted during the 50 μ s time-out period. Typical block erase times are given in *Table 18*.

After the Erase operation has started all Bus Read operations to the Banks being erased will output the Status Register on the Data Inputs/Outputs. See the section on the Status Register for more details.

After the Block Erase operation has completed the memory will return to the Read mode, unless an error has occurred.

When an error occurs, Bus Read operations to the Banks where the command was issued will continue to output the Status Register. A Read/Reset command must be issued to reset the error condition and return to Read mode.

6.1.7 Erase Suspend command

The Erase Suspend command may be used to temporarily suspend a Block or multiple Block Erase operation. One Bus Write operation specifying the Bank Address of one of the Blocks being erased is required to issue the command. Issuing the Erase Suspend command returns the whole device to Read mode.

The Program/Erase Controller will suspend within the Erase Suspend Latency time (see *Table 18* for value) of the Erase Suspend Command being issued. Once the Program/Erase Controller has stopped the memory will be set to Read mode and the Erase will be suspended. If the Erase Suspend command is issued during the period when the memory is waiting for an additional block (before the Program/Erase Controller starts) then the Erase is suspended immediately and will start immediately when the Erase Resume Command is issued. It is not possible to select any further blocks to erase after the Erase Resume.

During Erase Suspend it is possible to Read and Program cells in blocks that are not being erased; both Read and Program operations behave as normal on these blocks. If any attempt is made to program in a protected block or in the suspended block then the Program command is ignored and the data remains unchanged. The Status Register is not read and no error condition is given. Reading from blocks that are being erased will output the Status Register.

It is also possible to issue the Auto Select, Read CFI Query and Unlock Bypass commands during an Erase Suspend. The Read/Reset command must be issued to return the device to Read Array mode before the Resume command will be accepted.

During Erase Suspend a Bus Read operation to the Extended Block will output the Extended Block data. Once in the Extended Block mode, the Exit Extended Block command must be issued before the erase operation can be resumed.

6.1.8 Erase Resume command

The Erase Resume command is used to restart the Program/Erase Controller after an Erase Suspend. The command must include the Bank Address of the Erase-Suspended Bank, otherwise the Program/Erase Controller is not restarted.

The device must be in Read Array mode before the Resume command will be accepted. An Erase can be suspended and resumed more than once.

6.1.9 Program Suspend command

The Program Suspend command allows the system to interrupt a program operation so that data can be read from any block. When the Program Suspend command is issued during a program operation, the device suspends the program operation within the Program Suspend Latency time (see *Table 18* for value) and updates the Status Register bits. The Bank Addresses of the Block being programmed must be specified in the Program Suspend command.

After the program operation has been suspended, the system can read array data from any address. However, data read from Program-Suspended addresses is not valid.

The Program Suspend command may also be issued during a program operation while an erase is suspended. In this case, data may be read from any addresses not in Erase Suspend or Program Suspend. If a read is needed from the Extended Block area (One-time Program area), the user must use the proper command sequences to enter and exit this region.

The system may also issue the Auto Select command sequence when the device is in the Program Suspend mode. The system can read as many Auto Select codes as required. When the device exits the Auto Select mode, the device reverts to the Program Suspend mode, and is ready for another valid operation. See Auto Select command sequence for more information.

6.1.10 Program Resume command

After the Program Resume command is issued, the device reverts to programming. The controller can determine the status of the program operation using the DQ7 or DQ6 status bits, just as in the standard program operation. See Write Operation Status for more information.

The system must write the Program Resume command, specifying the Bank addresses of the Program-Suspended Block, to exit the Program Suspend mode and to continue the programming operation.

Further issuing of the Resume command is ignored. Another Program Suspend command can be written after the device has resumed programming.

6.1.11 Program command

The Program command can be used to program a value to one address in the memory array at a time. The command requires four Bus Write operations, the final Write operation latches the address and data in the internal state machine and starts the Program/Erase Controller.

Programming can be suspended and then resumed by issuing a Program Suspend command and a Program Resume command, respectively (see *Section 6.1.9: Program Suspend command* and *Section 6.1.10: Program Resume command* paragraphs).

If the address falls in a protected block then the Program command is ignored, the data remains unchanged. The Status Register is never read and no error condition is given.

After programming has started, Bus Read operations in the Bank being programmed output the Status Register content, while Bus Read operations to the other Bank output the contents of the memory array. See the section on the Status Register for more details. Typical program times are given in *Table 18*.

After the program operation has completed the memory will return to the Read mode, unless an error has occurred. When an error occurs Bus Read operations to the Bank where the command was issued will continue to output the Status Register. A Read/Reset command must be issued to reset the error condition and return to Read mode.

One of the Erase Commands must be used to set all the bits in a block or in the whole memory from '0' to '1'.

Table 11. Standard Commands, 8-bit mode⁽¹⁾⁽²⁾

Command		Length	Bus operations												
			1st		2nd		3rd		4th		5th		6th		
			Add	Data	Add	Data	Add	Data	Add	Data	Add	Data	Add	Data	
Read/Reset		1	X	F0											
		3	AAA	AA	555	55	X	F0							
Auto Select	Manufacturer Code	3	AAA	AA	555	55	(BKA) AAA	90	(3)	(3)					
	Device Code														
	Extended Block Protection Indicator														
	Block Protection Status														
Program		4	AAA	AA	555	55	AAA	A0	PA	PD					
Blank Verify Command		3	AAA	AA	555	55	BA	BC							
Verify		3	AAA	AA	555	55	BA	BC							
Chip Erase		6	AAA	AA	555	55	AAA	80	AAA	AA	555	55	AAA	10	
Block Erase		6 +	AAA	AA	555	55	AAA	80	AAA	AA	555	55	BA	30	
Erase/Program Suspend		1	BKA	B0											
Erase/Program Resume		1	BKA	30											
Read CFI Query		1	(BKA) AAA	98											

1. Grey cells represent Read cycles. The other cells are Write cycles.
2. X Don't Care, PA Program Address, PD Program Data, BA Any address in the Block, BKA Bank Address. All values in the table are in hexadecimal.
3. The Auto Select addresses and data are given in *Table 4: Read Electronic Signature, 8-bit mode*, and *Table 5: Block Protection, 8-bit mode*, except for A9 that is 'Don't Care'.

Table 12. Standard Commands, 16-bit mode⁽¹⁾⁽²⁾

Command		Length	Bus operations												
			1st		2nd		3rd		4th		5th		6th		
			Add	Data	Add	Data	Add	Data	Add	Data	Add	Data	Add	Data	
Read/Reset		1	X	F0											
		3	555	AA	2AA	55	X	F0							
Auto Select	Manufacturer Code	3	555	AA	2AA	55	(BKA) 555	90	(3)	(3)					
	Device Code														
	Extended Block Protection Indicator														
	Block Protection Status														
Program		4	555	AA	2AA	55	555	A0	PA	PD					
Blank Verify Command		3	555	AA	2AA	55	BA	BC							
Verify		3	555	AA	2AA	55	BA	BC							
Chip Erase		6	555	AA	2AA	55	555	80	555	AA	2AA	55	555	10	
Block Erase		6+	555	AA	2AA	55	555	80	555	AA	2AA	55	BA	30	
Erase/Program Suspend		1	BKA	B0											
Erase/Program Resume		1	BKA	30											
Read CFI Query		1	(BKA) 555	98											

1. Grey cells represent Read cycles. The other cells are Write cycles.
2. X Don't Care, PA Program Address, PD Program Data, BA Any address in the Block, BKA Bank Address. All values in the table are in hexadecimal.
3. The Auto Select addresses and data are given in *Table 7: Read Electronic Signature, 16-bit mode*, and *Table 8: Block Protection, 16-bit mode*, except for A9 that is 'Don't Care'.

6.2 Fast Program commands

The M29DW128F offers a set of Fast Program commands to improve the programming throughput:

- Write to Buffer and Program
- Double and Quadruple Word, Program
- Double, Quadruple and Octuple Byte Program
- Unlock Bypass.

See either *Table 14*, or *Table 13*, depending on the configuration that is being used, for a summary of the Fast Program commands.

When V_{PPH} is applied to the $V_{PP}/\text{Write Protect}$ pin the memory automatically enters the Fast Program mode. The user can then choose to issue any of the Fast Program commands. Care must be taken because applying a V_{PPH} to the V_{PP}/\overline{WP} pin will temporarily unprotect any protected block.

Only one bank can be programmed at any one time. The other bank must be in Read mode or Erase Suspend.

After programming has started, Bus Read operations in the Bank being programmed output the Status Register content, while Bus Read operations to the other Bank output the contents of the memory array. Fast program commands can be suspended and then resumed by issuing a Program Suspend command and a Program Resume command, respectively (see *Section 6.1.9: Program Suspend command* and *Section 6.1.10: Program Resume command* paragraphs.)

After the fast program operation has completed, the memory will return to the Read mode, unless an error has occurred. When an error occurs Bus Read operations to the Bank where the command was issued will continue to output the Status Register. A Read/Reset command must be issued to reset the error condition and return to Read mode. One of the Erase Commands must be used to set all the bits in a block or in the whole memory from '0' to '1'.

Typical Program times are given in *Table 18: Program, Erase Times and Program, Erase Endurance Cycles*.

6.2.1 Write to Buffer and Program command

The Write to Buffer and Program Command makes use of the device's 64-byte Write Buffer to speed up programming. 32 Words/64 bytes can be loaded into the Write Buffer. Each Write Buffer has the same A5-A22 addresses. The Write to Buffer and Program command dramatically reduces system programming time compared to the standard non-buffered Program command.

When issuing a Write to Buffer and Program command, the V_{PP}/\overline{WP} pin can be either held High, V_{IH} or raised to V_{PPH} .

See *Table 18* for details on typical Write to Buffer and Program times in both cases.

Five successive steps are required to issue the Write to Buffer and Program command:

1. The Write to Buffer and Program command starts with two unlock cycles.
2. The third Bus Write cycle sets up the Write to Buffer and Program command. The setup code can be addressed to any location within the targeted block.
3. The fourth Bus Write cycle sets up the number of Words/bytes to be programmed. Value N is written to the same block address, where N+1 is the number of Words/bytes to be programmed. N+1 must not exceed the size of the Write Buffer or the operation will abort.
4. The fifth cycle loads the first address and data to be programmed.
5. Use N Bus Write cycles to load the address and data for each Word/bytes into the Write Buffer. Addresses must lie within the range from the start address+1 to the start address + N-1. Optimum performance is obtained when the start address corresponds to a 64 byte boundary. If the start address is not aligned to a 64 byte boundary, the total programming time is doubled.

All the addresses used in the Write to Buffer and Program operation must lie within the same page.

To program the content of the Write Buffer, this command must be followed by a Write to Buffer and Program Confirm command.

If an address is written several times during a Write to Buffer and Program operation, the address/data counter will be decremented at each data load operation and the data will be programmed to the last word loaded into the Buffer.

Invalid address combinations or failing to follow the correct sequence of Bus Write cycles will abort the Write to Buffer and Program.

The Status Register bits DQ1, DQ5, DQ6, DQ7 can be used to monitor the device status during a Write to Buffer and Program operation.

It is not possible to detect Program operation fails when changing programmed data from '0' to '1', that is when reprogramming data in a portion of memory already programmed. The resulting data will be the logical OR between the previous value and the current value.

A Write to Buffer and Program Abort and Reset command must be issued to abort the Write to Buffer and Program operation and reset the device in Read mode.

During Write to Buffer and Program operations, the bank being programmed will accept Program/Erase Suspend commands.

See *Appendix E, Figure 27: Write to Buffer and Program flowchart and Pseudo Code*, for a suggested flowchart on using the Write to Buffer and Program command.

6.2.2 Write to Buffer and Program Confirm command

The Write to Buffer and Program Confirm command is used to confirm a Write to Buffer and Program command and to program the N+1 Words/bytes loaded in the Write Buffer by this command.

6.2.3 Write to Buffer and Program Abort and Reset command

The Write to Buffer and Program Abort and Reset command is used to abort Write to Buffer and Program command.

6.2.4 Double Word Program command

This is used to write two adjacent Words in x16 mode, simultaneously. The addresses of the two Words must differ only in A0.

Three bus write cycles are necessary to issue the command:

1. The first bus cycle sets up the command.
2. The second bus cycle latches the Address and the Data of the first Word to be written.
3. The third bus cycle latches the Address and the Data of the second Word to be written and starts the Program/Erase Controller.

6.2.5 Quadruple Word Program command

This is used to write a page of four adjacent Words, in x16 mode, simultaneously. The addresses of the four Words must differ only in A1 and A0.

Five bus write cycles are necessary to issue the command:

1. The first bus cycle sets up the command.
2. The second bus cycle latches the Address and the Data of the first Word to be written.
3. The third bus cycle latches the Address and the Data of the second Word to be written.
4. The fourth bus cycle latches the Address and the Data of the third Word to be written.
5. The fifth bus cycle latches the Address and the Data of the fourth Word to be written and starts the Program/Erase Controller.

6.2.6 Double byte Program Command

This is used to write two adjacent bytes in x8 mode, simultaneously. The addresses of the two bytes must differ only in DQ15A-1.

Three bus write cycles are necessary to issue the command:

1. The first bus cycle sets up the command.
2. The second bus cycle latches the Address and the Data of the first byte to be written.
3. The third bus cycle latches the Address and the Data of the second byte to be written and starts the Program/Erase Controller.

6.2.7 Quadruple byte Program command

This is used to write four adjacent bytes in x8 mode, simultaneously. The addresses of the four bytes must differ only in A0, DQ15A-1.

Five bus write cycles are necessary to issue the command.

1. The first bus cycle sets up the command.
2. The second bus cycle latches the Address and the Data of the first byte to be written.
3. The third bus cycle latches the Address and the Data of the second byte to be written.
4. The fourth bus cycle latches the Address and the Data of the third byte to be written.
5. The fifth bus cycle latches the Address and the Data of the fourth byte to be written and starts the Program/Erase Controller.

6.2.8 Octuple byte Program command

This is used to write eight adjacent bytes, in x8 mode, simultaneously. The addresses of the eight bytes must differ only in A1, A0 and DQ15A-1.

Nine bus write cycles are necessary to issue the command:

1. The first bus cycle sets up the command.
2. The second bus cycle latches the Address and the Data of the first byte to be written.
3. The third bus cycle latches the Address and the Data of the second byte to be written.
4. The fourth bus cycle latches the Address and the Data of the third byte to be written.
5. The fifth bus cycle latches the Address and the Data of the fourth byte to be written.
6. The sixth bus cycle latches the Address and the Data of the fifth byte to be written.
7. The seventh bus cycle latches the Address and the Data of the sixth byte to be written.
8. The eighth bus cycle latches the Address and the Data of the seventh byte to be written.
9. The ninth bus cycle latches the Address and the Data of the eighth byte to be written and starts the Program/Erase Controller.

6.2.9 Unlock Bypass command

The Unlock Bypass command is used in conjunction with the Unlock Bypass Program command to program the memory faster than with the standard program commands. When the cycle time to the device is long, considerable time saving can be made by using these commands. Three Bus Write operations are required to issue the Unlock Bypass command.

Once the Unlock Bypass command has been issued the bank enters Unlock Bypass mode. When in Unlock Bypass mode, only the Unlock Bypass Program and Unlock Bypass Reset commands are valid. The Unlock Bypass Program command can then be issued to program addresses within the bank, or the Unlock Bypass Reset command can be issued to return the bank to Read mode. In Unlock Bypass mode the memory can be read as if in Read mode.

6.2.10 Unlock Bypass Program command

The Unlock Bypass Program command can be used to program one address in the memory array at a time. The command requires two Bus Write operations, the final write operation latches the address and data and starts the Program/Erase Controller.

The Program operation using the Unlock Bypass Program command behaves identically to the Program operation using the Program command. The operation cannot be aborted, a Bus Read operation to the Bank where the command was issued outputs the Status Register. See the Program command for details on the behavior.

6.2.11 Unlock Bypass Reset command

The Unlock Bypass Reset command can be used to return to Read/Reset mode from Unlock Bypass mode. Two Bus Write operations are required to issue the Unlock Bypass Reset command. Read/Reset command does not exit from Unlock Bypass mode.

Table 13. Fast Program Commands, 8-bit mode⁽¹⁾

Command	Length	Bus Write operations																	
		1st		2nd		3rd		4th		5th		6th		7th		8th		9th	
		Add	Data	Add	Data	Add	Data	Add	Data	Add	Data	Add	Data	Add	Data	Add	Data	Add	Data
Write to Buffer and Program	N + 5	AAA	AA	555	55	BA	25	BA	N ⁽²⁾	PA ⁽³⁾	PD	WBL ⁽⁴⁾	PD						
Write to Buffer and Program Abort and Reset	3	AAA	AA	555	55	AAA	F0												
Write to Buffer and Program Confirm	1	BA ⁽⁵⁾	29																
Double byte Program	3	AAA	50	PA0	PD0	PA1	PD1												
Quadruple byte Program	5	AAA	56	PA0	PD0	PA1	PD1	PA2	PD2	PA3	PD3								
Octuple byte Program	9	AAA	8B	PA0	PD0	PA1	PD1	PA2	PD2	PA3	PD3	PA4	PD4	PA5	PD5	PA6	PD6	PA7	PD7
Unlock Bypass	3	AAA	AA	555	55	AAA	20												
Unlock Bypass Program	2	X	A0	PA	PD														
Unlock Bypass Reset	2	X	90	X	00														

1. X Don't Care, PA Program Address, PD Program Data, BA Any address in the Block, BKA Bank Address, WBL Write Buffer Location. All values in the table are in hexadecimal.
2. The maximum number of cycles in the command sequence is 68. N+1 is the number of bytes to be programmed during the Write to Buffer and Program operation.
3. Each buffer has the same A5-A22 addresses. A0-A4 and A-1 are used to select a byte within the N+1 byte page.
4. The 6th cycle has to be issued N time. WBL scans the byte inside the page.
5. BA must be identical to the address loaded during the Write to buffer and Program 3rd and 4th cycles.

Table 14. Fast Program Commands, 16-bit mode⁽¹⁾

Command	Length	Bus Write operations											
		1st		2nd		3rd		4th		5th		6th	
		Add	Data	Add	Data	Add	Data	Add	Data	Add	Data	Add	Data
Write to Buffer and Program	N+5	555	AA	2AA	55	BA	25	BA	N ⁽²⁾	PA ⁽³⁾	PD	WBL ⁽⁴⁾	PD
Write to Buffer and Program Abort and Reset	3	555	AA	2AA	55	555	F0						
Write to Buffer and Program Confirm	1	BA ⁽⁵⁾	29										
Double Word Program	3	555	50	PA0	PD0	PA1	PD1						
Quadruple Word Program	5	555	56	PA0	PD0	PA1	PD1	PA2	PD2	PA3	PD3		
Unlock Bypass	3	555	AA	2AA	55	555	20						
Unlock Bypass Program	2	X	A0	PA	PD								
Unlock Bypass Reset	2	X	90	X	00								

1. X Don't Care, PA Program Address, PD Program Data, BA Any address in the Block, BKA Bank Address, WBL Write Buffer Location. All values in the table are in hexadecimal.
2. The maximum number of cycles in the command sequence is 36. N+1 is the number of Words to be programmed during the Write to Buffer and Program operation.
3. Each buffer has the same A5-A22 addresses. A0-A4 are used to select a Word within the N+1 Word page.
4. The 6th cycle has to be issued N time. WBL scans the Word inside the page.
5. BA must be identical to the address loaded during the Write to buffer and Program 3rd and 4th cycles.

6.3 Block Protection commands

Blocks or groups of blocks can be protected against accidental program, erase or read operations. The Protection Groups are shown in *Appendix A, Table 34: Block Addresses and Protection Groups*. The device block protection scheme is shown in *Figure 7: Software Protection scheme* and *Figure 6: Block Protection State diagram*. See either *Table 15*, or *Table 16*, depending on the configuration that is being used, for a summary of the Block Protection commands.

Only the commands related to the Extended Block Protection are available in both 8 bit and 16 bit memory configuration. The other block protection commands are available in 16-bit configuration only.

6.3.1 Enter Extended Block command

The M29DW128F has one extra 256-byte block (Extended Block) that can only be accessed using the Enter Extended Block command.

Three Bus Write cycles are required to issue the Extended Block command. Once the command has been issued the device enters the Extended Block mode where all Bus Read or Program operations are conducted on the Extended Block. Once the device is in the Extended Block mode, the Extended Block is addressed by using the addresses occupied by the boot blocks in the other operating modes (see *Table 34: Block Addresses and Protection Groups*).

The device remains in Extended Block mode until the Exit Extended Block command is issued or power is removed from the device. After power-up or a hardware reset, the device reverts to the Read mode where commands issued to the Boot Block Address space will address the Boot Blocks.

Note that when the device is in the Extended Block mode, the V_{PP}/\overline{WP} pin cannot be used for fast programming and the Unlock Bypass mode is not available.

The Extended Block cannot be erased, and can be treated as one-time programmable (OTP) memory. In Extended Block mode only array cell locations (Bank A) with the same addresses as the Extended Block are not accessible. In Extended Block mode dual operations are allowed and the Extended Block physically belongs to Bank A.

In Extended Block mode, Erase, Chip Erase, Erase Suspend and Erase resume commands are not allowed.

To exit from the Extended Block mode the Exit Extended Block command must be issued.

The Extended Block can be protected by setting the Extended Block Protection bit to '1'; however once protected the protection cannot be undone.

6.3.2 Exit Extended Block command

The Exit Extended Block command is used to exit from the Extended Block mode and return the device to Read mode. Four Bus Write operations are required to issue the command.

6.3.3 Set Extended Block Protection bit command

The Set Extended Block Protection bit command programs the Extended Block Protection bit to '1' thus preventing the second section of the Extended Block from being programmed.

A Read/Reset command must be issued to abort a Set Extended Block Protection bit command.

Six successive steps are required to issue the Set Extended Block Protection bit command.

1. The command starts with two unlock cycles.
2. The third Bus Write cycle sets up the Set Extended Block Protection bit command.
3. The fourth Bus Write Cycle programs the Extended Block Protection bit to '1'.
4. The last two cycles verify the value programmed at the Extended Block Protection bit address: if bit DQ0 of Data Inputs/Outputs is set to '1', it indicates that the Extended Block Protection bit has been successfully programmed. If DQ0 is '0', the Set Extended Block Protection bit command must be issued and verified again.

6.3.4 Verify Extended Block Protection bit command

The Verify Extended Block Protection bit command reads the status of the Extended Block Protection bit on bit DQ0 of the Data Inputs/Outputs. If DQ0 is '1', the second section of the Extended Block is protected from program operations.

6.3.5 Password Program command

The Password Program Command is used to program the 64-bit Password used in Password Protection mode.

Four cycles are required to program the Password:

1. The first two cycles are unlock cycles.
2. The third cycle issues the Password Program command.
3. The fourth cycle inputs the 16-bit data required to program the Password.

To program the 64-bit Password, the complete command sequence must be entered four times at four consecutive addresses selected by A1 to A0.

Read operations can be used to read the Status Register during a Password Program operation. All other operations are forbidden.

The Password can be checked by issuing a Password Verify command.

Once Password Program operation has completed, a Read/ Reset command must be issued to return the device to Read mode. The Password Protection mode can then be selected.

By default, all Password bits are set to '1'.

6.3.6 Password Verify command

The Password Verify Command is used to verify the Password used in Password Protection mode. To verify the 64-bit Password, the complete command sequence must be entered four times at four consecutive addresses selected by A1 to A0. If the Password Mode Locking bit is programmed and the user attempts to verify the Password, the device will output all F's onto the I/O data bus. The Password is output regardless of the bank address.

The user must issue a Read/reset command to return the device to Read mode.

Dual operations are not allowed during a Password Verify operation.

6.3.7 Password Protection Unlock command

The Password Protection Unlock command is used to clear the Lock-Down bit in order to unprotect all Non-Volatile Modify Protection bits when the device is in Password Protection mode. The Password Protection Unlock command must be issued along with the correct Password.

The complete command sequence must be entered for each 16 bits of the Password.

There must be a 2 μ s delay between successive Password Protection Unlock commands in order to prevent hackers from cracking the Password by trying all possible 64-bit combinations. If this delay is not respected, the latest command will be ignored.

6.3.8 Set Password Protection mode command

The Set Password Protection Mode command puts the device in Password Protection mode by programming the Password Protection Mode Lock bit to '1'. This command can be issued either with the Reset/Block Temporary Unprotect pin, \overline{RP} , at V_{ID} or at V_{IH} .

Six cycles are required to issue a Set Password Protection Mode command:

1. The first two cycles are unlock cycles.
2. The third cycle issues the command.
3. The fourth and fifth cycles select the address (see *Table 34*).
4. The last cycle verifies if the operation has been successful. If DQ0 is set to '1', the device has successfully entered the Password Protection mode. If DQ0 is '0', the operation has failed and the command must be re-issued.

There must be a 100 μ s delay between the fourth and fifth cycles.

Once the Password Protection mode is activated the device will permanently remain in this mode.

6.3.9 Verify Password Protection mode command

The Verify Password Protection Mode command reads the status of the Password Protection Mode Lock bit. If it is '1', the device is in Password Protection mode.

6.3.10 Set Standard Protection mode command

The Set Standard Protection Mode command puts the device in Standard Protection mode by programming the Standard Protection Mode Lock bit to '1'.

Six cycles are required to issue the Standard Protection Mode command:

1. The first two cycles are unlock cycles.
2. The third cycle issues the program command.
3. The fourth and fifth cycles select the address (see *Table 34*).
4. The last cycle verifies if the operation has been successful. If DQ0 is set to '1', the Standard Protection Mode has been successfully activated. If DQ0 is '0', the operation has failed and the command must be re-issued.

There must be a 100µs delay between the fourth and fifth cycles.

Once the Standard Protection mode is activated the device will permanently remain in this mode.

6.3.11 Verify Standard Protection mode command

The Verify Standard Protection Mode command reads the status of the Standard Protection Mode Lock bit. If it is '1', the device is in Standard Protection mode.

6.3.12 Set Non-Volatile Modify Protection bit command

A block or group of blocks can be protected from program or erase by issuing a Set Non-Volatile Modify Protection bit command along with the block address. This command sets the Non-Volatile Modify Protection bit to '1' for a given block or group of blocks.

Six cycles are required to issue the command:

1. The first two cycles are unlock cycles.
2. The third cycle issues the program command.
3. The fourth and fifth cycles select the address (see *Table 34*).
4. The last cycle verifies if the operation has been successful. If DQ0 is set to '1', the Non-Volatile Modify Protection bit has been successfully programmed. If DQ0 is '0', the operation has failed and the command must be re-issued.

There must be a 100µs delay between the fourth and fifth cycles.

The Non-Volatile Modify Protection bits are erased simultaneously by issuing a Clear Non-Volatile Modify Protection bits command except if the Lock-Down bit is set to '1'.

The Non-Volatile Modify Protection bits can be set a maximum of 100 times.

6.3.13 Verify Non-Volatile Modify Protection bit command

The status of a Non-Volatile Modify Protection bit for a given block or group of blocks can be read by issuing a Verify Non-Volatile Modify Protection Bit command along with the block address.

6.3.14 Clear Non-Volatile Modify Protection bits command

This command is used to clear all Non-Volatile Modify Protection bits. No specific block address is required. If the Lock-Down bit is set to '1', the command will fail.

Six cycles are required to issue a Clear Non-Volatile Modify Protection bits command:

1. The first two cycles are unlock cycles.
2. The third cycle issues the command.
3. The last three cycles verify if the operation has been successful. If DQ0 is set to '0', all Non-Volatile Modify Protection bits have been successfully cleared. If DQ0 is '1', the operation has failed and the command must be re-issued.

There must be a 12ms delay between the fourth and fifth cycles.

6.3.15 Set Lock bit command

The Set Lock bit command individually sets the Lock bit to '1' for a given block or group of blocks.

If the Non-Volatile Lock bit for the same block or group of blocks is set, the block is locked regardless of the value of the Lock bit. (see *Table 10: Block Protection status*).

6.3.16 Clear Lock bit command

The Clear Lock bit command individually clears (sets to '0') the Lock bit for a given block or group of blocks.

If the Non-Volatile Lock bit for the same block or group of blocks is set, the block or group of blocks remains locked (see *Table 10: Block Protection status*).

6.3.17 Verify Lock bit command

The status of a Lock bit for a given block can be read by issuing a Verify Lock bit command along with the block address.

6.3.18 Set Lock-Down bit command

This command is used to set the Lock-Down bit to '1' thus protecting the Non-Volatile Modify Protection bits from program and erase.

There is no Unprotect Lock-Down bit command.

6.3.19 Verify Lock-Down bit command

This command is used to read the status of the Lock-Down bit. The status is output on bit DQ1. If DQ1 is '1', all the Non-Volatile Modify Protection bits are protected from program or erase operations.

Table 15. Block Protection Commands, 8-bit mode⁽¹⁾⁽²⁾

Command	Length	Bus operations											
		1st		2nd		3rd		4th		5th		6th	
		Add	Data	Add	Data	Add	Data	Add	Data	Add	Data	Add	Data
Set Extended Block Protection bit	6	AAA	AA	555	55	AAA	60	OW	68	OW ₍₃₎	48	OW	DQ0
Verify Extended Block Protection bit	4	AAA	AA	555	55	AAA	60	OW	DQ0				
Enter Extended Block	3	AAA	AA	555	55	AAA	88						
Exit Extended Block	4	AAA	AA	555	55	AAA	90	X	00				

1. OW Extended Block Protection bit Address (A7-A0='00011010'), X Don't Care. All values in the table are in hexadecimal.
2. Grey cells represent Read cycles. The other cells are Write cycles.
3. A 100µs timeout is required between cycles 4 and 5.

Table 16. Block Protection Commands, 16-bit mode⁽¹⁾⁽²⁾⁽³⁾⁽⁴⁾

Command	Length	Bus operations													
		1st		2nd		3rd		4th		5th		6th		7th	
		Add	Data	Add	Data	Add	Data	Add	Data	Add	Data	Add	Data	Add	Data
Set Extended Block Protection bit ⁽⁵⁾⁽⁶⁾	6	555	AA	2AA	55	555	60	OW	68	OW	48	OW	DQ0		
Verify Extended Block Protection bit	4	555	AA	2AA	55	555	60	OW	DQ0						
Enter Extended Block	3	555	AA	2AA	55	555	88								
Exit Extended Block	4	555	AA	2AA	55	555	90	X	00						
Password Program ⁽⁵⁾⁽⁷⁾⁽⁸⁾	4	555	AA	2AA	55	555	38	X[0-3]	PW [0-3]						
Password Verify ⁽⁸⁾⁽⁹⁾	4	555	AA	2AA	55	555	C8	PWA [0-3]	RPW [0-3]						
Password Protection Unlock ⁽⁷⁾⁽¹⁰⁾⁽¹¹⁾	7	555	AA	2AA	55	555	28	PWA[0]	RPW[0]	PWA [1]	RPW [1]	PWA [2]	RPW [2]	PWA [3]	RPW [3]
Set Password Protection mode ⁽⁵⁾⁽⁶⁾	6	555	AA	2AA	55	555	60	PL	68	PL	48	PL	DQ0		
Verify Password Protection mode	4	555	AA	2AA	55	555	60	PL	DQ0						
Set Non-Volatile Modify Protection bit ⁽⁵⁾⁽⁶⁾	6	555	AA	2AA	55	555	60	(BA)/NVMP	68	(BA)/NVMP	48	(BA)/NVMP	DQ0		

Table 16. Block Protection Commands, 16-bit mode (continued)⁽¹⁾⁽²⁾⁽³⁾⁽⁴⁾

Command	Length	Bus operations													
		1st		2nd		3rd		4th		5th		6th		7th	
		Add	Data	Add	Data	Add	Data	Add	Data	Add	Data	Add	Data	Add	Data
Verify Non-Volatile Modify Protection bit	4	555	AA	2AA	55	555	60	(BA)/NVMP	48	(BA)/NVMP	DQ0				
Clear Non-Volatile Modify Protection bits ⁽¹²⁾⁽¹³⁾⁽¹⁴⁾	6	555	AA	2AA	55	555	60	NVMP	60	(BA)/NVMP	40	(BA)/NVMP	DQ0		
Set Lock-Down bit	3	555	AA	2AA	55	555	78								
Verify Lock-Down bit ⁽¹⁵⁾	4	555	AA	2AA	55	555	58	BA	DQ1						
Set Lock bit ⁽⁷⁾	4	555	AA	2AA	55	555	48	BA	X1h						
Clear Lock bit ⁽⁷⁾	4	555	AA	2AA	55	555	48	BA	X0h						
Verify Lock bit	4	555	AA	2AA	55	555	58	BA	DQ0						
Set Standard Protection mode ⁽⁵⁾⁽⁶⁾	6	555	AA	2AA	55	555	60	SL	68	SL	48	SL	DQ0		
Verify Standard Protection mode ⁽⁵⁾	4	555	AA	2AA	55	555	60	SL	DQ0						

1. Grey cells represent Read cycles. The other cells are Write cycles.
2. SA Protection Group Address, BA Any address in the Block, BKA Bank Address, SL Standard Protection Mode Lock bit Address, PL Password Protection Mode Lock bit Address, PW Password Data, PWA Password Address, RPW Password Data Being Verified, NVMP Non-Volatile Modify Protection bit Address, OW Extended Block Protection bit Address, X Don't Care. All values in the table are in hexadecimal.
3. Addresses are described in *Table 34*.
4. During Unlock and Command cycles, if the lower address bits are 555h or 2AAh then the address bits higher than A11 (except where BA is required) and data bits higher than DQ7 are Don't Care.
5. A Reset Command must be issued to return to the Read mode.
6. The 4th Bus Write cycle programs a protection bit (Extended Block Protection bit, Password Protection Mode Lock bit, Standard Protection Mode Lock bit, and a block NVMP bit). The 5th and 6th cycles verify that the bit has been successfully programmed when DQ0=1. If DQ0=0 in the 6th cycle, the program command must be issued again and verified again. A 100µs delay is required between the 4th and the 5th cycle.
7. Data is latched on the rising edge of \bar{W} .
8. The entire command sequence must be entered for each portion of the password.
9. The command sequence returns FFh if the Password Protection Mode locking bit is set.
10. The password is written over four consecutive cycles, at addresses [0-3]
11. A 2µs timeout is required between any two portions of the password.
12. A 10ms delay is required between the 4th and the 5th cycle.
13. A 12ms timeout is required between cycles 4 and 5.
14. Cycle 4 erases all Non-Volatile Modify Protection bits. Cycles 5 and 6 verify that the bits have been successfully cleared when DQ0=0. If DQ0=1 in the 6th cycle, the erase command must be issued again and verified again. Before issuing the erase command, all Non-Volatile Modify Protection bits should be programmed to prevent over erasure.
15. DQ1=1 if the Non-Volatile Modify Protection bit is locked, DQ1 = 0 if it is unlocked.

Table 17. Protection Command Addresses

Bit	Condition	Address Inputs A7-A0	Other Address Inputs
Password Protection Mode Lock bit Address (PL)	\overline{RP} at V_{IH}	00001010	X
	\overline{RP} at V_{ID}	10001010	X
Standard Protection Mode Lock bit Address (SL)		00010010	X
Non-Volatile Modify Protection bit Address (NVMP)		00000010	Block Protection Group Address
Extended Block Protection bit Address (OW)		00011010	X

Table 18. Program, Erase Times and Program, Erase Endurance Cycles

Parameter		Min	Typ ⁽¹⁾⁽²⁾	Max ⁽²⁾	Unit
Chip Erase			80	400 ⁽³⁾	s
Block Erase (64 kbytes)			0.8	6 ⁽⁴⁾	s
Erase Suspend Latency Time				50 ⁽⁴⁾	μs
Byte Program	Single or Multiple byte Program (1, 2, 4 or 8 bytes at-a-time)		10	200 ⁽³⁾	μs
	Write to Buffer and Program (64 bytes at-a-time)	$V_{PP}/\overline{WP}=V_{PPH}$	90	700 ⁽³⁾	μs
		$V_{PP}/\overline{WP}=V_{IH}$	280	1400 ⁽³⁾	μs
Word Program	Single or Multiple Word Program (1, 2 or 4 Words at-a-time)		10	200 ⁽³⁾	μs
	Write to Buffer and Program (32 Words at-a-time)	$V_{PP}/\overline{WP}=V_{PPH}$	90	700 ⁽³⁾	μs
		$V_{PP}/\overline{WP}=V_{IH}$	280	1400 ⁽³⁾	μs
Chip Program (byte by byte)			80	400 ⁽³⁾	s
Chip Program (Word by Word)			40	200 ⁽³⁾	s
Chip Program (Quadruple byte or Double Word)			20	100 ⁽³⁾	s
Chip Program (Octuple byte or Quadruple Word)			10	50 ⁽³⁾	s
Program Suspend Latency Time			5	15	μs
Program/Erase Cycles (per Block)		100,000			cycles
Data Retention		20			years

1. Typical values measured at room temperature and nominal voltages.
2. Sampled, but not 100% tested.
3. Maximum value measured at worst case conditions for both temperature and V_{CC} after 100,00 program/erase cycles.
4. Maximum value measured at worst case conditions for both temperature and V_{CC} .

7 Status Register

The M29DW128F has one Status Register. The Status Register provides information on the current or previous Program or Erase operations executed in each bank. The various bits convey information and errors on the operation. Bus Read operations from any address within the Bank, always read the Status Register during Program and Erase operations. It is also read during Erase Suspend when an address within a block being erased is accessed.

The bits in the Status Register are summarized in *Table 19: Status Register bits*.

7.1 Data Polling bit (DQ7)

The Data Polling bit can be used to identify whether the Program/Erase Controller has successfully completed its operation or if it has responded to an Erase Suspend. The Data Polling bit is output on DQ7 when the Status Register is read.

During Program operations the Data Polling bit outputs the complement of the bit being programmed to DQ7. After successful completion of the Program operation the memory returns to Read mode and Bus Read operations from the address just programmed output DQ7, not its complement.

During Erase operations the Data Polling bit outputs '0', the complement of the erased state of DQ7. After successful completion of the Erase operation the memory returns to Read mode.

In Erase Suspend mode the Data Polling bit will output a '1' during a Bus Read operation within a block being erased. The Data Polling bit will change from a '0' to a '1' when the Program/Erase Controller has suspended the Erase operation.

Figure 8: Data Polling flowchart, gives an example of how to use the Data Polling bit. A Valid Address is the address being programmed or an address within the block being erased.

7.2 Toggle bit (DQ6)

The Toggle bit can be used to identify whether the Program/Erase Controller has successfully completed its operation or if it has responded to an Erase Suspend. The Toggle bit is output on DQ6 when the Status Register is read.

During a Program/Erase operation the Toggle bit changes from '0' to '1' to '0', etc., with successive Bus Read operations at any address. After successful completion of the operation the memory returns to Read mode.

During Erase Suspend mode the Toggle bit will output when addressing a cell within a block being erased. The Toggle bit will stop toggling when the Program/Erase Controller has suspended the Erase operation.

Figure 9: Toggle flowchart, gives an example of how to use the Data Toggle bit. *Figure 16* and *Figure 17* describe Toggle bit timing waveform.

7.3 Error bit (DQ5)

The Error bit can be used to identify errors detected by the Program/Erase Controller. The Error bit is set to '1' when a Program, Block Erase or Chip Erase operation fails to write the correct data to the memory. If the Error bit is set a Read/Reset command must be issued before other commands are issued. The Error bit is output on DQ5 when the Status Register is read.

Note that the Program command cannot change a bit set to '0' back to '1' and attempting to do so will set DQ5 to '1'. A Bus Read operation to that address will show the bit is still '0'. One of the Erase commands must be used to set all the bits in a block or in the whole memory from '0' to '1'.

7.4 Erase Timer bit (DQ3)

The Erase Timer bit can be used to identify the start of Program/Erase Controller operation during a Block Erase command. Once the Program/Erase Controller starts erasing the Erase Timer bit is set to '1'. Before the Program/Erase Controller starts the Erase Timer bit is set to '0' and additional blocks to be erased may be written to the Command Interface. The Erase Timer bit is output on DQ3 when the Status Register is read.

7.5 Alternative Toggle bit (DQ2)

The Alternative Toggle bit can be used to monitor the Program/Erase controller during Erase operations. The Alternative Toggle bit is output on DQ2 when the Status Register is read.

During Chip Erase and Block Erase operations the Toggle bit changes from '0' to '1' to '0', etc., with successive Bus Read operations from addresses within the blocks being erased. A protected block is treated the same as a block not being erased. Once the operation completes the memory returns to Read mode.

During Erase Suspend the Alternative Toggle bit changes from '0' to '1' to '0', etc. with successive Bus Read operations from addresses within the blocks being erased. Bus Read operations to addresses within blocks not being erased will output the memory array data as if in Read mode.

After an Erase operation that causes the Error bit to be set, the Alternative Toggle bit can be used to identify which block or blocks have caused the error. The Alternative Toggle bit changes from '0' to '1' to '0', etc. with successive Bus Read Operations from addresses within blocks that have not erased correctly. The Alternative Toggle bit does not change if the addressed block has erased correctly.

Figure 16 and Figure 17 describe Alternative Toggle bit timing waveform.

7.6 Write to Buffer and Program Abort bit (DQ1)

The Write to Buffer and Program Abort bit, DQ1, is set to '1' when a Write to Buffer and Program operation aborts. The Write to Buffer and Program Abort and Reset command must be issued to return the device to Read mode (see Write to Buffer and Program in COMMANDS section).

Table 19. Status Register bits⁽¹⁾⁽²⁾

Operation	Address	DQ7	DQ6	DQ5	DQ3	DQ2	DQ1	R \bar{B}
Program	Bank Address	$\overline{DQ7}$	Toggle	0	–	–	0	0
Program During Erase Suspend	Bank Address	$\overline{DQ7}$	Toggle	0	–	–	–	0
Write to Buffer and Program Abort	Bank Address	$\overline{DQ7}$	Toggle	0	–	–	1	0
Program Error	Bank Address	$\overline{DQ7}$	Toggle	1	–	–	–	Hi-Z
Chip Erase	Any Address	0	Toggle	0	1	Toggle	–	0
Block Erase before timeout	Erasing Block	0	Toggle	0	0	Toggle	–	0
	Non-Erasing Block	0	Toggle	0	0	No Toggle	–	0
Block Erase	Erasing Block	0	Toggle	0	1	Toggle	–	0
	Non-Erasing Block	0	Toggle	0	1	No Toggle	–	0
Erase Suspend	Erasing Block	1	No Toggle	0	–	Toggle	–	Hi-Z
	Non-Erasing Block	Data read as normal					–	Hi-Z
Erase Error	Good Block Address	0	Toggle	1	1	No Toggle	–	Hi-Z
	Faulty Block Address	0	Toggle	1	1	Toggle	–	Hi-Z

1. Unspecified data bits should be ignored.
2. Figure 16 and Figure 17 describe Toggle and Alternative Toggle bits timing waveforms.

Figure 8. Data Polling flowchart

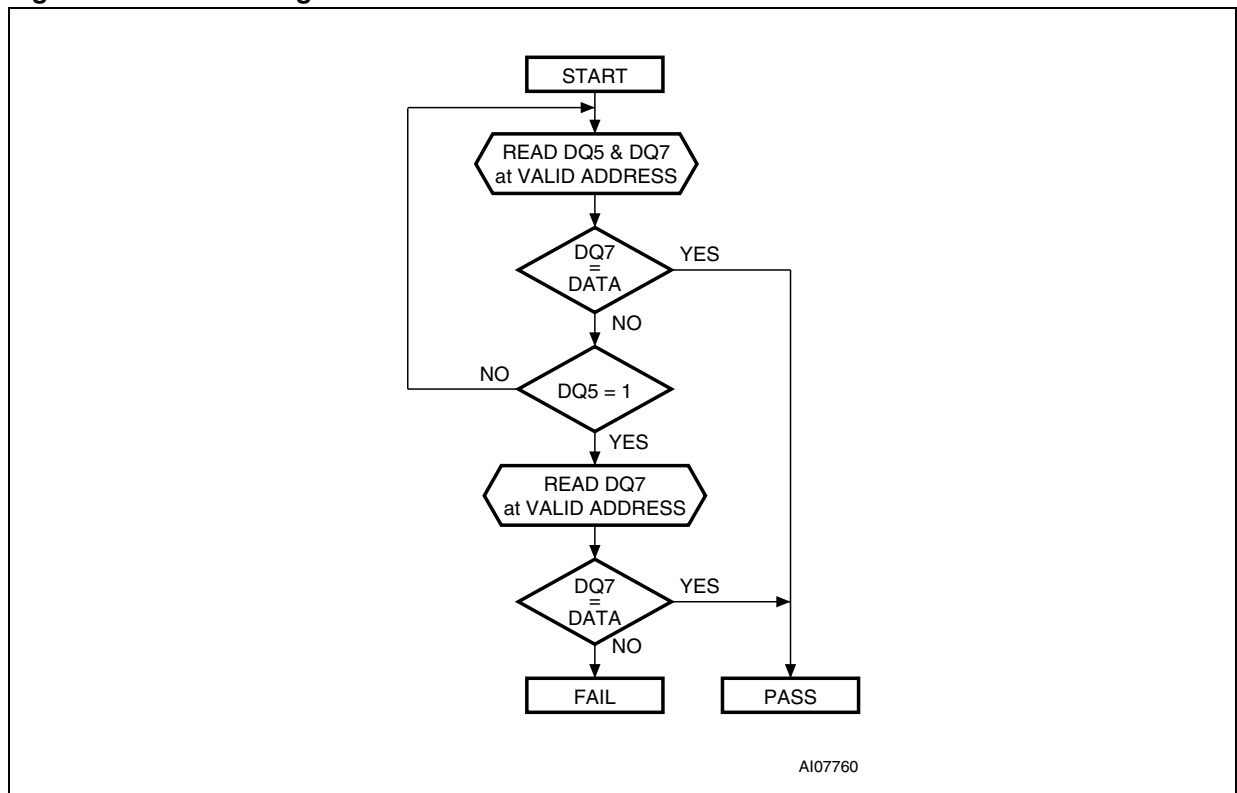
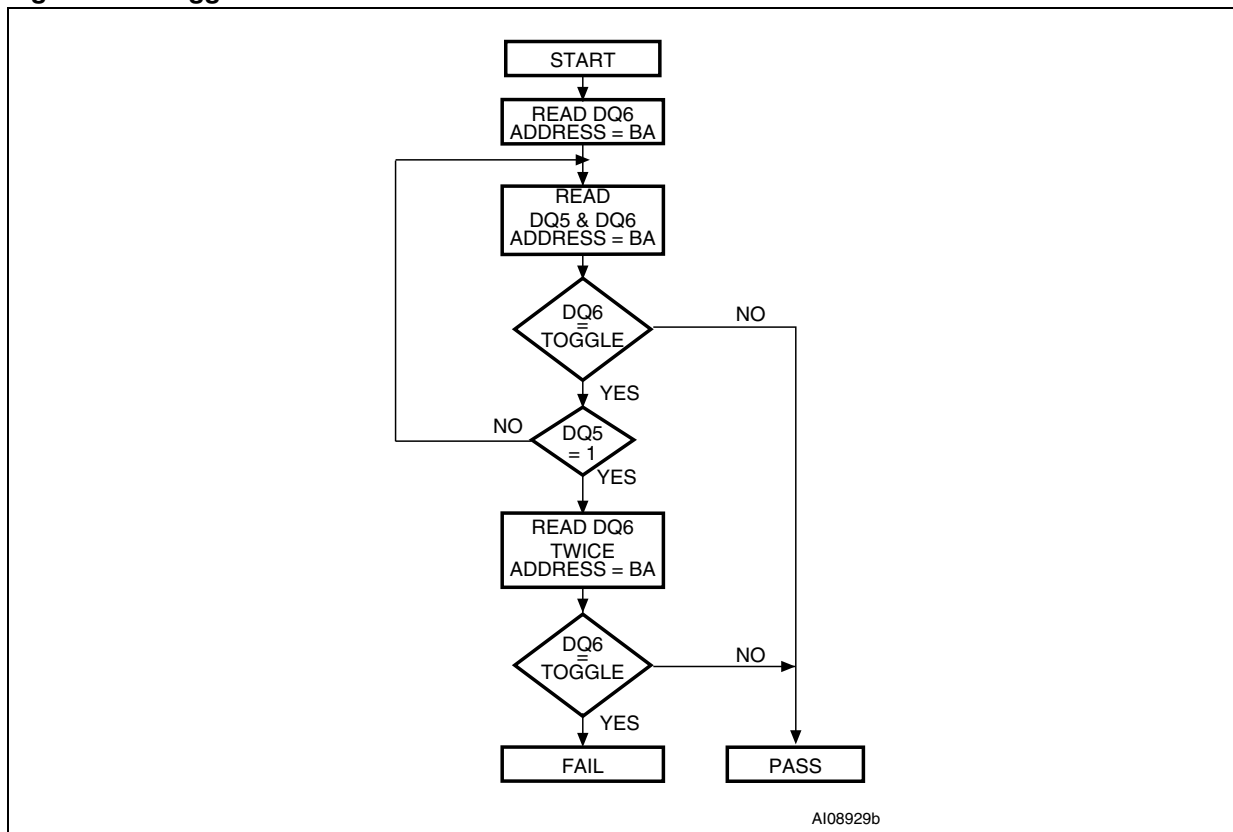

Figure 9. Toggle flowchart



1. BA = Address of Bank being Programmed or Erased.

8 Dual Operations and Multiple Bank architecture

The Multiple Bank Architecture of the M29DW128F gives greater flexibility for software developers to split the code and data spaces within the memory array. The Dual Operations feature simplifies the software management of the device by allowing code to be executed from one bank while another bank is being programmed or erased.

The Dual Operations feature means that while programming or erasing in one bank, read operations are possible in another bank with zero latency.

Only one bank at a time is allowed to be in program or erase mode. However, certain commands can cross bank boundaries, which means that during an operation only the banks that are not concerned with the cross bank operation are available for dual operations. For example, if a Block Erase command is issued to erase blocks in both Bank A and Bank B, then only Banks C or D are available for read operations while the erase is being executed.

If a read operation is required in a bank, which is programming or erasing, the program or erase operation can be suspended.

Also if the suspended operation was erase then a program command can be issued to another block, so the device can have one block in Erase Suspend mode, one programming and other banks in read mode.

By using a combination of these features, read operations are possible at any moment.

Table 20 and Table 21 show the dual operations possible in other banks and in the same bank. Note that only the commonly used commands are represented in these tables.

Table 20. Dual Operations allowed in other Banks⁽¹⁾

Status of Bank	Commands allowed in another bank							
	Read/Reset	Read Status Register ⁽²⁾	Read CFI Query	Auto Select	Program	Erase	Program/Erase Suspend	Program/Erase Resume
Idle	Yes	Yes ⁽³⁾	Yes	Yes	Yes	Yes	Yes ⁽³⁾	Yes ⁽⁴⁾
Programming	Yes	No	No	No	–	–	No	No
Erasing	Yes	No	No	No	–	–	No	No
Program Suspended	Yes	No	Yes	Yes	No	No	-	Yes ⁽⁵⁾
Erase Suspended	Yes	No	Yes	Yes	Yes	No	-	Yes ⁽⁶⁾

1. If several banks are involved in a program or erase operation, then only the banks that are not concerned with the operation are available for dual operations.
2. Read Status Register is not a command. The Status Register can be read during a block program or erase operation.
3. Only after a program or erase operation in that bank.
4. Only after a Program or Erase Suspend command in that bank.
5. Only a Program Resume is allowed if the bank was previously in Program Suspend mode.
6. Only an Erase Resume is allowed if the bank was previously in Erase Suspend mode.

Table 21. Dual Operations allowed in same Bank

Status of Bank	Commands allowed in same Bank							
	Read/Reset	Read Status Register (1)	Read CFI Query	Auto Select	Program	Erase	Program/Erase Suspend	Program/Erase Resume
Idle	Yes	Yes	Yes	Yes	Yes	Yes	Yes ⁽²⁾	Yes ⁽³⁾
Programming	No	Yes	No	No	–	–	Yes ⁽⁴⁾	–
Erasing	No	Yes	No	No	–	No	Yes ⁽⁵⁾	–
Program Suspended	Yes ⁽⁶⁾	No	Yes	Yes	No	–	–	Yes
Erase Suspended	Yes ⁽⁶⁾	Yes ⁽⁷⁾	Yes	Yes	Yes ⁽⁶⁾	No	–	Yes

1. Read Status Register is not a command. The Status Register can be read by addressing the block being programmed or erased.
2. Only after a program or erase operation in that bank.
3. Only after a Program or Erase Suspend command in that bank.
4. Only a Program Suspend.
5. Only an Erase suspend.
6. Not allowed in the Block or Word that is being erased or programmed.
7. The Status Register can be read by addressing the block being erase suspended.

9 Maximum rating

Stressing the device above the rating listed in the Absolute Maximum Ratings table may cause permanent damage to the device. Exposure to Absolute Maximum Rating conditions for extended periods may affect device reliability. These are stress ratings only and operation of the device at these or any other conditions above those indicated in the Operating sections of this specification is not implied. Refer also to the Numonyx SURE Program and other relevant quality documents.

Table 22. Absolute maximum ratings

Symbol	Parameter	Min	Max	Unit
T_{BIAS}	Temperature Under Bias	-50	125	°C
T_{STG}	Storage Temperature	-65	150	°C
V_{IO}	Input or Output voltage ⁽¹⁾⁽²⁾	-0.6	$V_{CC} + 0.6$	V
V_{CC}	Supply voltage	-0.6	4	V
V_{ID}	Identification voltage	-0.6	13.5	V
$V_{PP}^{(3)}$	Program voltage	-0.6	13.5	V

1. Minimum voltage may undershoot to -2V during transition and for less than 20ns during transitions.
2. Maximum voltage may overshoot to $V_{CC} + 2V$ during transition and for less than 20ns during transitions.
3. V_{PP} must not remain at 12V for more than a total of 80hrs.

10 DC and AC parameters

This section summarizes the operating measurement conditions, and the DC and AC characteristics of the device. The parameters in the DC and AC characteristics Tables that follow, are derived from tests performed under the Measurement Conditions summarized in *Table 23: Operating and AC measurement conditions*. Designers should check that the operating conditions in their circuit match the operating conditions when relying on the quoted parameters.

Table 23. Operating and AC measurement conditions

Parameter	M29DW128F				Unit
	60		70		
	Min	Max	Min	Max	
V _{CC} supply voltage	2.7	3.6	2.7	3.6	V
Ambient Operating Temperature	-40	85	-40	85	°C
Load capacitance (C _L)	30		30		pF
Input Rise and Fall Times		10		10	ns
Input pulse voltages	0 to V _{CC}		0 to V _{CC}		V
Input and Output Timing Ref. voltages	V _{CC} /2		V _{CC} /2		V

Figure 10. AC measurement I/O waveform

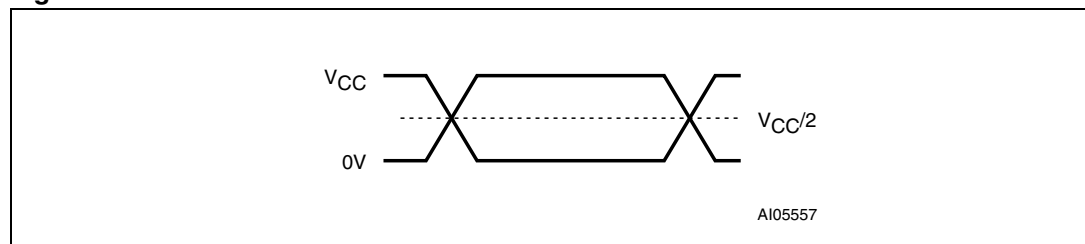

Figure 11. AC measurement Load Circuit

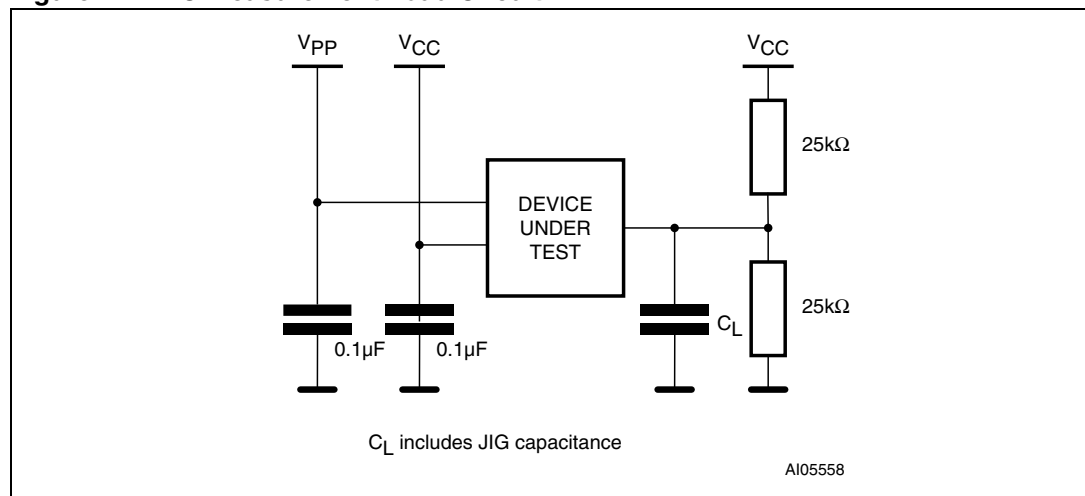

Table 24. Device capacitance

Symbol	Parameter	Test condition	Min	Max ⁽¹⁾	Unit
C _{IN}	Input capacitance	V _{IN} = 0V		6	pF
C _{OUT}	Output capacitance	V _{OUT} = 0V		12	pF

1. Sampled only, not 100% tested.

Table 25. DC Characteristics

Symbol	Parameter	Test condition	Min	Max	Unit
I _{LI}	Input Leakage Current	0V ≤ V _{IN} ≤ V _{CC}		±1	μA
I _{LO}	Output Leakage Current	0V ≤ V _{OUT} ≤ V _{CC}		±1	μA
I _{CC1} ⁽¹⁾	Supply Current (Read)	$\bar{E} = V_{IL}, \bar{G} = V_{IH},$ f = 6MHz		10	mA
I _{CC2}	Supply Current (Standby)	$\bar{E} = V_{CC} \pm 0.2V,$ $\overline{RP} = V_{CC} \pm 0.2V$		100	μA
I _{CC3} ⁽¹⁾⁽²⁾	Supply Current (Program/Erase)	Program/Erase Controller active	$V_{PP}/\overline{WP} = V_{IL} \text{ or } V_{IH}$	20	mA
			$V_{PP}/\overline{WP} = V_{PPH}$	20	mA
V _{IL}	Input Low voltage		-0.5	0.8	V
V _{IH}	Input High voltage		0.7V _{CC}	V _{CC} + 0.3	V
V _{PPH}	Voltage for V _{PP} / \overline{WP} Program Acceleration	V _{CC} = 2.7V ±10%	11.5	12.5	V
I _{PP}	Current for V _{PP} / \overline{WP} Program Acceleration	V _{CC} = 2.7V ±10%		15	mA
V _{OL}	Output Low voltage	I _{OL} = 1.8mA		0.45	V
V _{OH}	Output High voltage	I _{OH} = -100μA	V _{CC} - 0.4		V
V _{ID}	Identification voltage		11.5	12.5	V
V _{LKO}	Program/Erase Lockout supply voltage		1.8	2.3	V

1. In Dual operations the Supply Current will be the sum of I_{CC1}(read) and I_{CC3}(program/erase).

2. Sampled only, not 100% tested.

Figure 12. Random Read AC waveforms

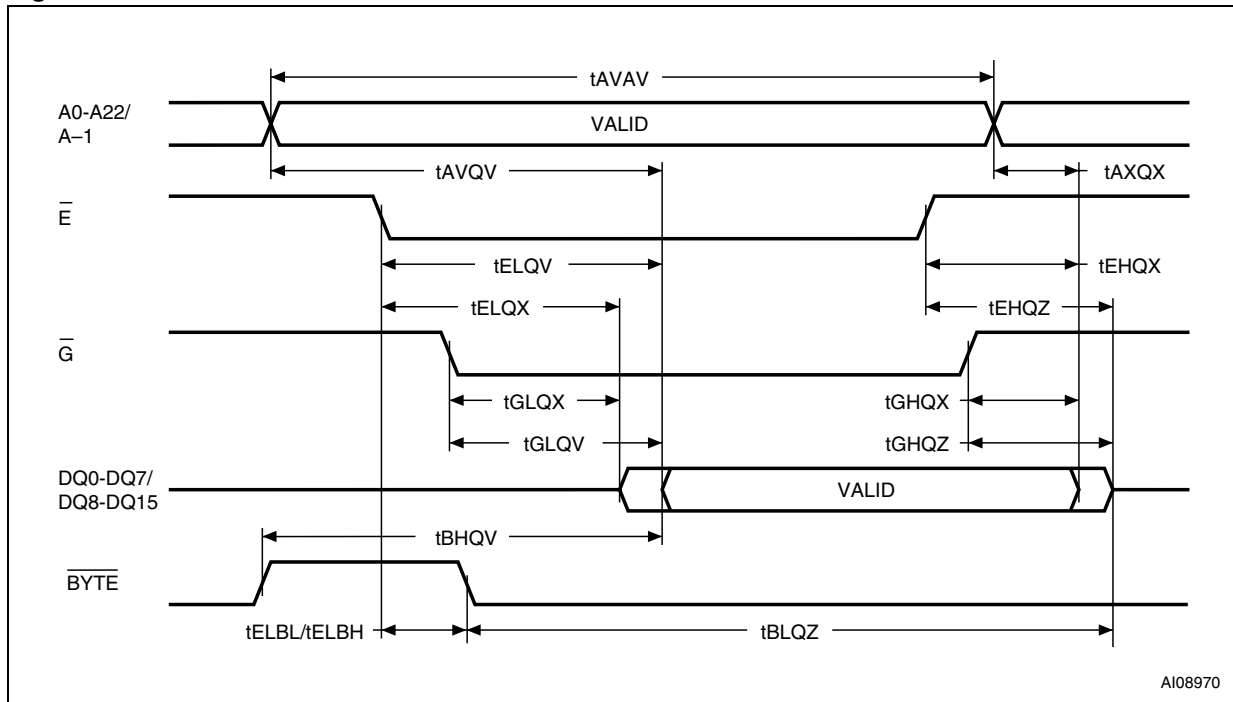

A108970

Figure 13. Page Read AC waveforms

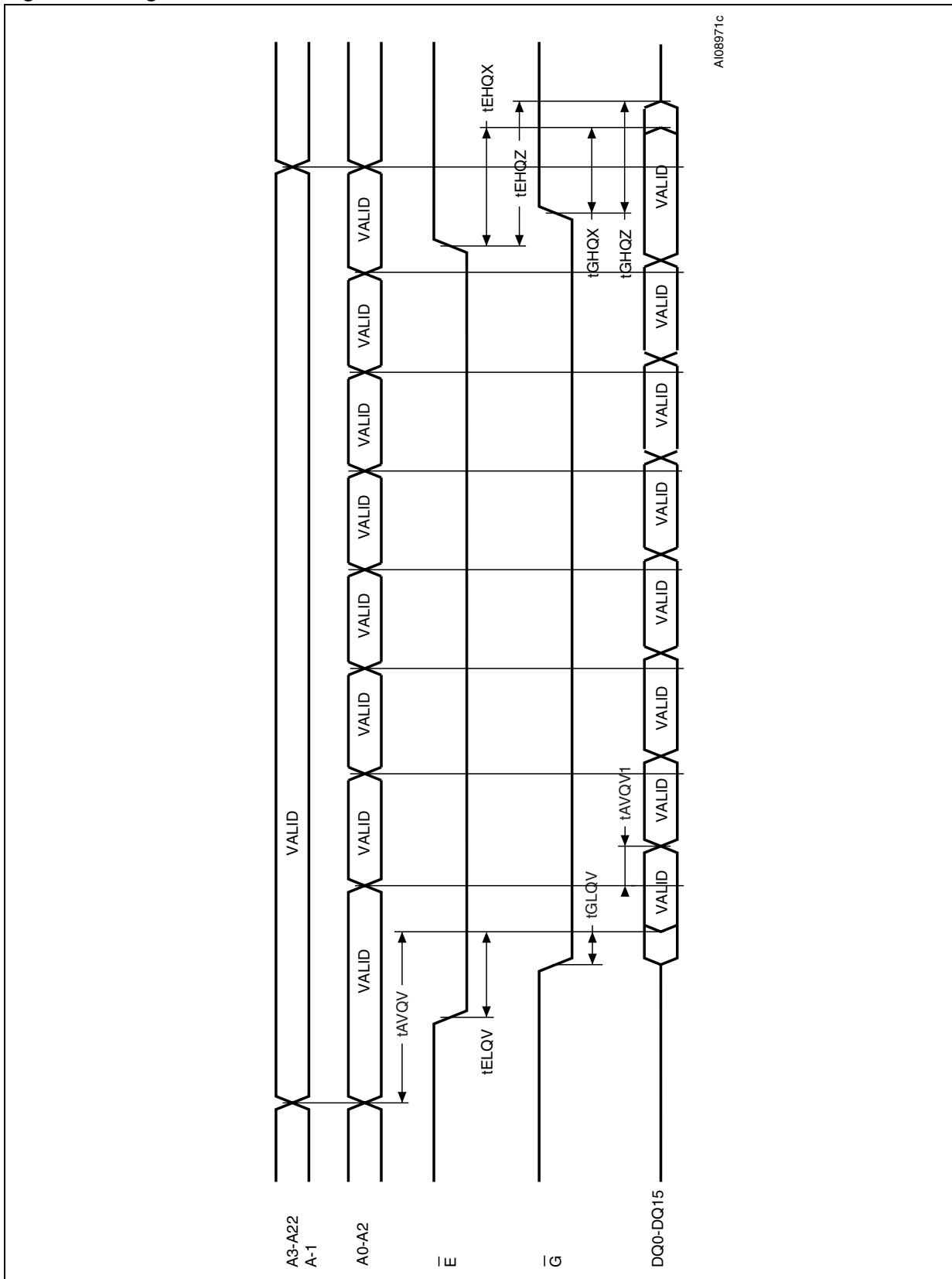

Table 26. Read AC characteristics

Symbol	Alt	Parameter	Test condition		M29DW128F		Unit
					60	70	
t_{AVAV}	t_{RC}	Address Valid to Next Address Valid	$\overline{E} = V_{IL},$ $\overline{G} = V_{IL}$	Min	60	70	ns
t_{AVQV}	t_{ACC}	Address Valid to Output Valid	$\overline{E} = V_{IL},$ $\overline{G} = V_{IL}$	Max	60	70	ns
t_{AVQV1}	t_{PAGE}	Address Valid to Output Valid (Page)	$\overline{E} = V_{IL},$ $\overline{G} = V_{IL}$	Max	25	30	ns
$t_{ELQX}^{(1)}$	t_{LZ}	Chip Enable Low to Output Transition	$\overline{G} = V_{IL}$	Min	0	0	ns
t_{ELQV}	t_{CE}	Chip Enable Low to Output Valid	$\overline{G} = V_{IL}$	Max	60	70	ns
$t_{GLQX}^{(1)}$	t_{OLZ}	Output Enable Low to Output Transition	$\overline{E} = V_{IL}$	Min	0	0	ns
t_{GLQV}	t_{OE}	Output Enable Low to Output Valid	$\overline{E} = V_{IL}$	Max	20	25	ns
$t_{EHQZ}^{(1)}$	t_{HZ}	Chip Enable High to Output Hi-Z	$\overline{G} = V_{IL}$	Max	25	25	ns
$t_{GHQZ}^{(1)}$	t_{DF}	Output Enable High to Output Hi-Z	$\overline{E} = V_{IL}$	Max	25	25	ns
t_{EHQX} t_{GHQX} t_{AXQX}	t_{OH}	Chip Enable, Output Enable or Address Transition to Output Transition		Min	0	0	ns
t_{ELBL} t_{ELBH}	t_{ELFL} t_{ELFH}	Chip Enable to \overline{BYTE} Low or High ⁽²⁾		Max	5	5	ns
t_{BLQZ}	t_{FLQZ}	\overline{BYTE} Low to Output Hi-Z ⁽²⁾		Max	25	25	ns
t_{BHQV}	t_{FHQV}	\overline{BYTE} High to Output Valid ⁽²⁾		Max	30	30	ns

1. Sampled only, not 100% tested.

2. TSOP56 package only.

Figure 14. Write AC waveforms, Write Enable Controlled

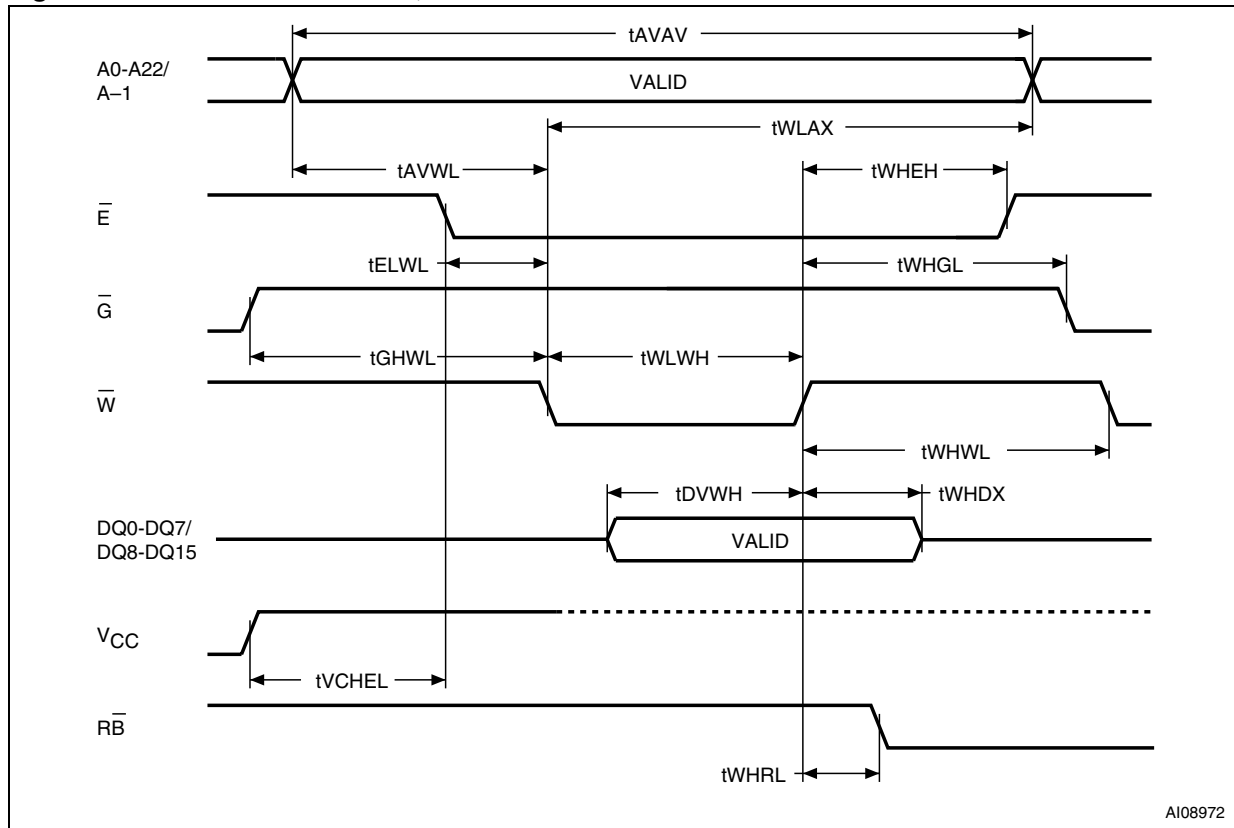

AI08972

Table 27. Write AC characteristics, Write Enable Controlled

Symbol	Alt	Parameter		M29DW128F		Unit
				60	70	
t_{AVAV}	t_{WC}	Address Valid to Next Address Valid	Min	60	70	ns
t_{ELWL}	t_{CS}	Chip Enable Low to Write Enable Low	Min	0	0	ns
t_{WLWH}	t_{WP}	Write Enable Low to Write Enable High	Min	45	45	ns
t_{DVWH}	t_{DS}	Input Valid to Write Enable High	Min	45	45	ns
t_{WHDX}	t_{DH}	Write Enable High to Input Transition	Min	0	0	ns
t_{WHEH}	t_{CH}	Write Enable High to Chip Enable High	Min	0	0	ns
t_{WHWL}	t_{WPH}	Write Enable High to Write Enable Low	Min	30	30	ns
t_{AVWL}	t_{AS}	Address Valid to Write Enable Low	Min	0	0	ns
t_{WLAX}	t_{AH}	Write Enable Low to Address Transition	Min	45	45	ns
t_{GHWL}		Output Enable High to Write Enable Low	Min	0	0	ns
t_{WHGL}	t_{OEHL}	Write Enable High to Output Enable Low	Min	0	0	ns
$t_{WHRL}^{(1)}$	t_{BUSY}	Program/Erase Valid to \overline{RB} Low	Max	30	30	ns
t_{VCHL}	t_{VCS}	V_{CC} High to Chip Enable Low	Min	50	50	μ s

1. Sampled only, not 100% tested.

Figure 16. Toggle and Alternative Toggle bits mechanism, Chip Enable Controlled

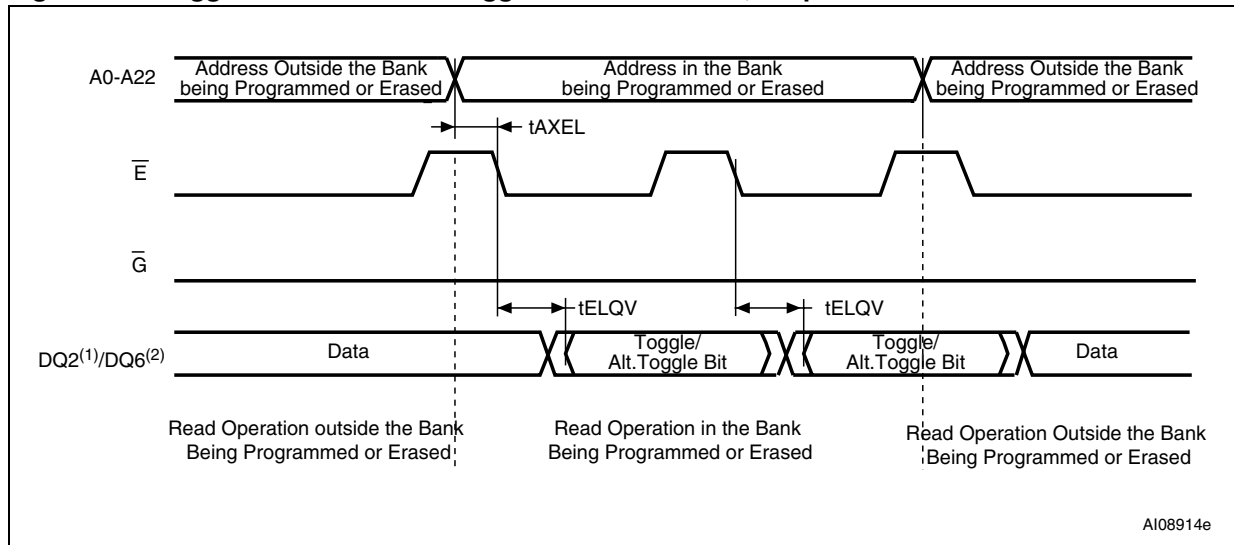

1. The Toggle bit is output on DQ6.
2. The Alternative Toggle bit is output on DQ2.
3. Refer to *Table 26: Read AC characteristics* for the value of t_{ELQV} .

Figure 17. Toggle and Alternative Toggle bits mechanism, Output Enable Controlled

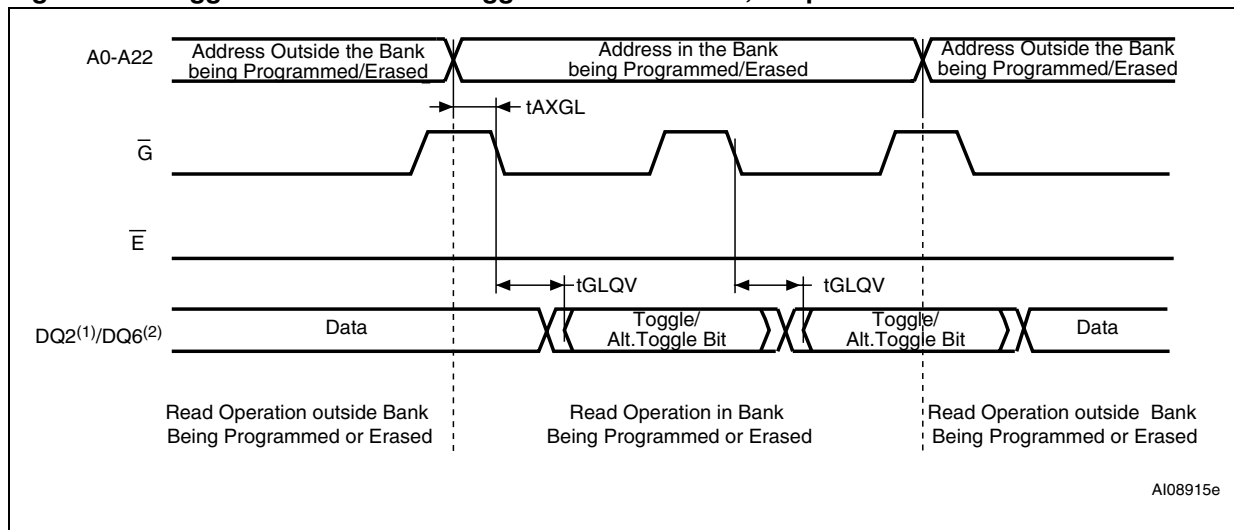

1. The Toggle bit is output on DQ6.
2. The Alternative Toggle bit is output on DQ2.
3. Refer to *Table 26: Read AC characteristics* for the value of t_{GLQV} .

Table 29. Toggle and Alternative Toggle bits AC characteristics

Symbol	Alt	Parameter	M29DW128F		Unit	
			60	70		
t_{AXEL}		Address Transition to Chip Enable Low	Min	10	10	ns
t_{AXGL}		Address Transition to Output Enable Low	Min	10	10	ns

Figure 18. Reset/Block Temporary Unprotect AC waveforms (No Program/Erase ongoing)

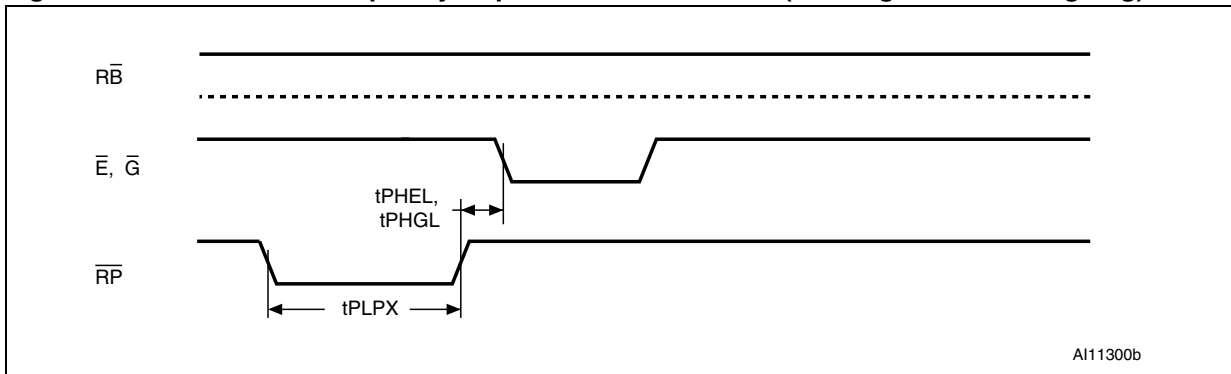

Figure 19. Reset/Block Temporary Unprotect During Program/Erase Operation AC waveforms

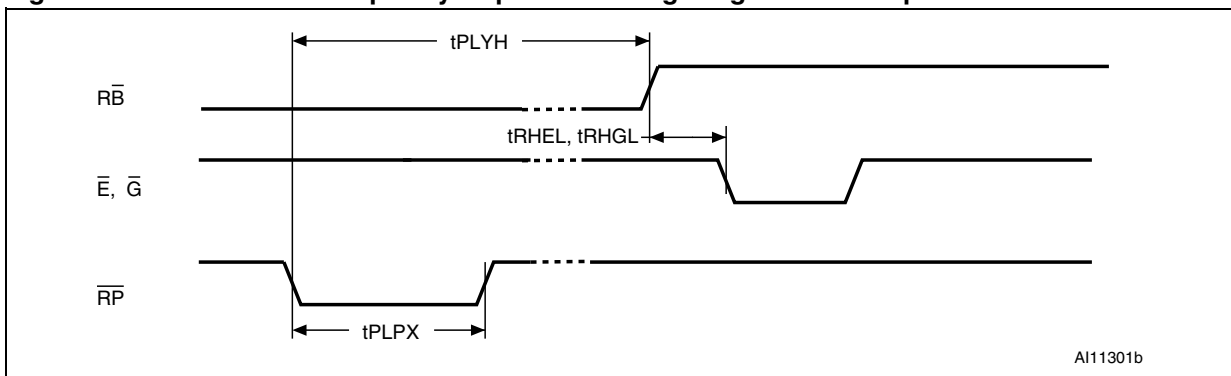

Figure 20. Accelerated Program Timing waveforms

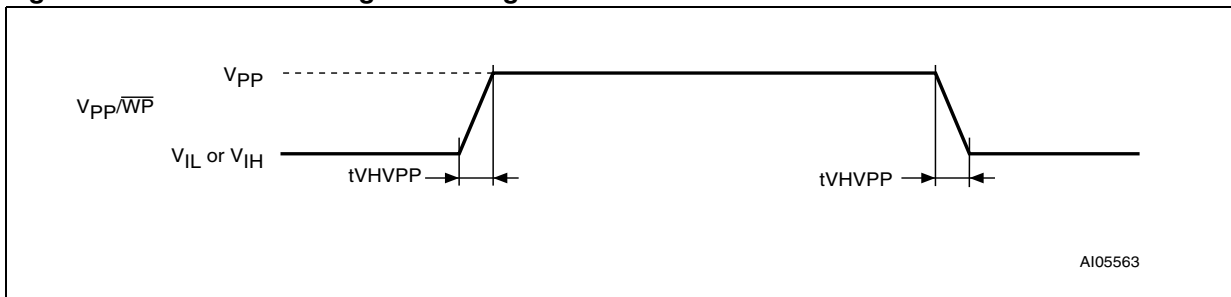

Table 30. Reset/Block Temporary Unprotect AC characteristics

Symbol	Alt	Parameter		M29DW128F		Unit
				60	70	
$t_{PLYH}^{(1)}$	t_{READY}	\overline{RP} Low to Read mode, during Program or Erase	Max	20		μs
t_{PLPX}	t_{RP}	\overline{RP} Pulse Width	Min	500		ns
$t_{PHEL}^{(1)}$ $t_{PHGL}^{(1)}$	t_{RH}	\overline{RP} High to Write Enable Low, Chip Enable Low, Output Enable Low	Min	50		ns
	t_{RPD}	\overline{RP} Low to Standby Mode.	Min	20		ns
$t_{RHEL}^{(1)}$ $t_{RHGL}^{(1)}$	t_{RB}	$R\overline{B}$ High to Write Enable Low, Chip Enable Low, Output Enable Low	Min	0		ns

1. Sampled only, not 100% tested.

11 Package mechanical

Figure 21. TSOP56 – 56 lead Plastic Thin Small Outline, 14 x 20mm, package outline

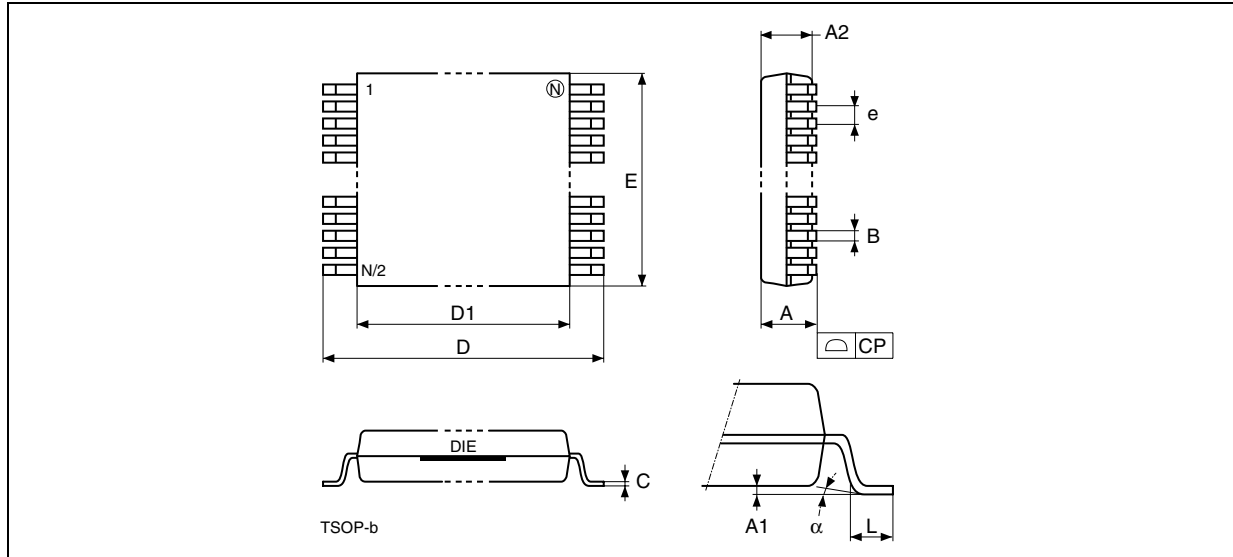

1. Drawing is not to scale.

Table 31. TSOP56 – 56 lead Plastic Thin Small Outline, 14 x 20mm, package mechanical data

Symbol	millimeters			inches		
	Typ	Min	Max	Typ	Min	Max
A			1.200			0.0472
A1	0.100	0.050	0.150	0.0039	0.0020	0.0059
A2	1.000	0.950	1.050	0.0394	0.0374	0.0413
B	0.220	0.170	0.270	0.0087	0.0067	0.0106
C		0.100	0.210		0.0039	0.0083
CP			0.100			0.0039
D	20.000	19.800	20.200	0.7874	0.7795	0.7953
D1	18.400	18.300	18.500	0.7244	0.7205	0.7283
e	0.500	–	–	0.0197	–	–
E	14.000	13.900	14.100	0.5512	0.5472	0.5551
L	0.600	0.500	0.700	0.0236	0.0197	0.0276
alpha	3°	0	5°	3°	0	5°
N	56			56		

Figure 22. TBGA64 10x13mm - 8x8 active ball array, 1mm pitch, package outline

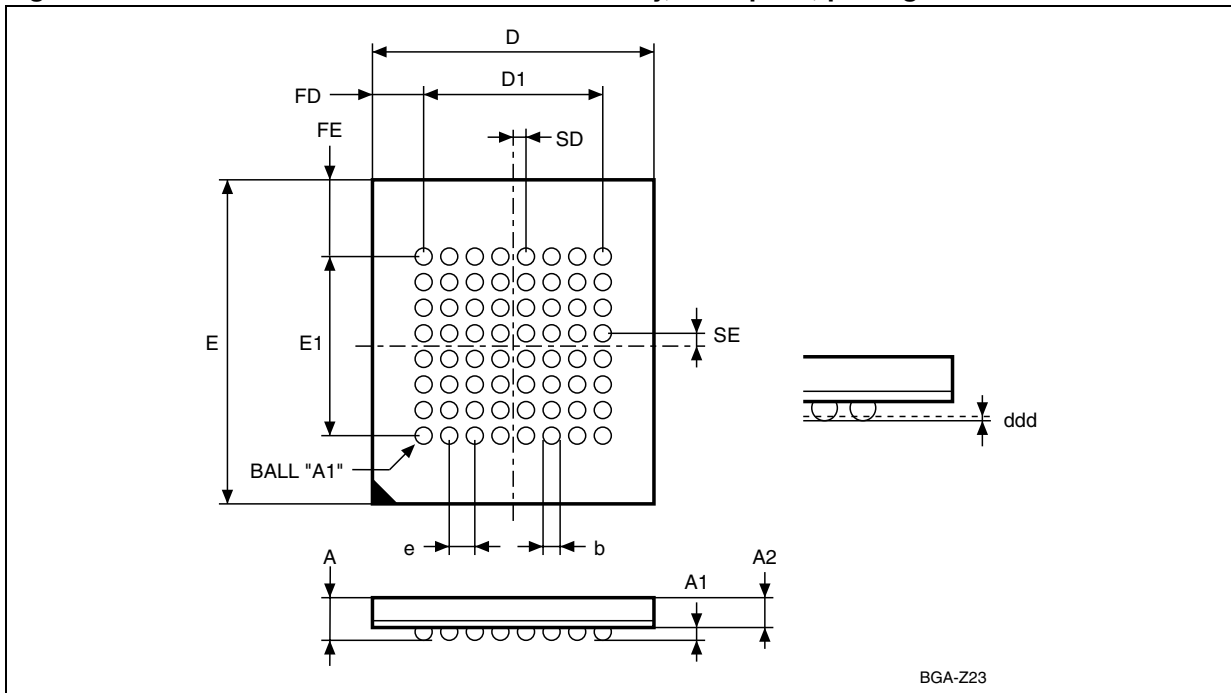

1. Drawing is not to scale.

Table 32. TBGA64 10x13mm - 8x8 active ball array, 1mm pitch, package mechanical data

Symbol	millimeters			inches		
	Typ	Min	Max	Typ	Min	Max
A			1.200			0.0472
A1	0.300	0.200	0.350	0.0118	0.0079	0.0138
A2	0.800			0.0315		
b		0.350	0.500		0.0138	0.0197
D	10.000	9.900	10.100	0.3937	0.3898	0.3976
D1	7.000	-	-	0.2756	-	-
ddd			0.100			0.0039
e	1.000	-	-	0.0394	-	-
E	13.000	12.900	13.100	0.5118	0.5079	0.5157
E1	7.000	-	-	0.2756	-	-
FD	1.500	-	-	0.0591	-	-
FE	3.000	-	-	0.1181	-	-
SD	0.500	-	-	0.0197	-	-
SE	0.500	-	-	0.0197	-	-

12 Part numbering

Table 33. Ordering information scheme

Example:	M29DW128F	70	NF	1	T
Device type	M29				
Architecture	D = Dual Operation				
Operating voltage	W = $V_{CC} = 2.7$ to $3.6V$				
Device function	128F = 128 Mbit (x8/x16), Multiple Bank, Page, Boot Block, 16+48+48+16 partitioning, Flash Memory				
Speed	60 = 60ns 70 = 70ns				
Package	NF = TSOP56: 14 x 20 mm ZA = TBGA64: 10 x13mm, 1mm pitch				
Temperature range	1 = 0 to 70 °C 6 = -40 to 85 °C				
Option	Blank = Standard Packing T = Tape & Reel Packing E = ECOPACK Package, Standard Packing F = ECOPACK Package, Tape & Reel 24mm Packing				

Note: This product is also available with the Extended Block factory locked. For further details and ordering information contact your nearest Numonyx sales office.

Devices are shipped from the factory with the memory content bits erased to '1'.

For a list of available options (Speed, Package, etc.) or for further information on any aspect of this device, please contact your nearest Numonyx Sales Office.

Appendix A Block addresses and Read/Modify Protection Groups

Table 34. Block Addresses and Protection Groups

Bank	Block	Size (kbytes/KWords)	Protection Block Group	(x8)	(x16)
Bank A	0	8/4	Protection Group	000000h-001FFFh ⁽¹⁾	000000h-000FFFh ⁽¹⁾
	1	8/4	Protection Group	002000h-003FFFh ⁽¹⁾	001000h-001FFFh ⁽¹⁾
	2	8/4	Protection Group	004000h-005FFFh ⁽¹⁾	002000h-002FFFh ⁽¹⁾
	3	8/4	Protection Group	006000h-007FFFh ⁽¹⁾	003000h-003FFFh ⁽¹⁾
	4	8/4	Protection Group	008000h-009FFFh ⁽¹⁾	004000h-004FFFh ⁽¹⁾
	5	8/4	Protection Group	00A000h-00BFFFh ⁽¹⁾	005000h-005FFFh ⁽¹⁾
	6	8/4	Protection Group	00C000h-00DFFFh ⁽¹⁾	006000h-006FFFh ⁽¹⁾
	7	8/4	Protection Group	00E000h-00FFFFh ⁽¹⁾	007000h-007FFFh ⁽¹⁾
	8	64/32	Protection Group	010000h-01FFFFh	008000h-00FFFFh
	9	64/32		020000h-02FFFFh	010000h-017FFFh
	10	64/32		030000h-03FFFFh	018000h-01FFFFh
	11	64/32	Protection Group	040000h-04FFFFh	020000h-027FFFh
	12	64/32		050000h-05FFFFh	028000h-02FFFFh
	13	64/32		060000h-06FFFFh	030000h-037FFFh
	14	64/32		070000h-07FFFFh	038000h-03FFFFh
	15	64/32	Protection Group	080000h-08FFFFh	040000h-047FFFh
	16	64/32		090000h-09FFFFh	048000h-04FFFFh
	17	64/32		0A0000h-0AFFFFh	050000h-057FFFh
	18	64/32		0B0000h-0BFFFFh	058000h-05FFFFh
	19	64/32	Protection Group	0C0000h-0CFFFFh	060000h-067FFFh
	20	64/32		0D0000h-0DFFFFh	068000h-06FFFFh
	21	64/32		0E0000h-0EFFFFh	070000h-077FFFh
	22	64/32		0F0000h-0FFFFFh	078000h-07FFFFh
	23	64/32	Protection Group	100000h-10FFFFh	080000h-087FFFh
	24	64/32		110000h-11FFFFh	088000h-08FFFFh
	25	64/32		120000h-12FFFFh	090000h-097FFFh
26	64/32	130000h-13FFFFh		098000h-09FFFFh	

Table 34. Block Addresses and Protection Groups (continued)

Bank	Block	Size (kbytes/KWords)	Protection Block Group	(x8)	(x16)
Bank A	27	64/32	Protection Group	140000h-14FFFFh	0A0000h-0A7FFFh
	28	64/32		150000h-15FFFFh	0A8000h-0AFFFFh
	29	64/32		160000h-16FFFFh	0B0000h-0B7FFFh
	30	64/32		170000h-17FFFFh	0B8000h-0BFFFFh
	31	64/32	Protection Group	180000h-18FFFFh	0C0000h-0C7FFFh
	32	64/32		190000h-19FFFFh	0C8000h-0CFFFFh
	33	64/32		1A0000h-1AFFFFh	0D0000h-0D7FFFh
	34	64/32		1B0000h-1BFFFFh	0D8000h-0DFFFFh
	35	64/32	Protection Group	1C0000h-1CFFFFh	0E0000h-0E7FFFh
	36	64/32		1D0000h-1DFFFFh	0E8000h-0EFFFFh
	37	64/32		1E0000h-1EFFFFh	0F0000h-0F7FFFh
	38	64/32		1F0000h-1FFFFFh	0F8000h-0FFFFFh
Bank B	39	64/32	Protection Group	200000h-20FFFFh	100000h-107FFFh
	40	64/32		210000h-21FFFFh	108000h-10FFFFh
	41	64/32		220000h-22FFFFh	110000h-117FFFh
	42	64/32		230000h-23FFFFh	118000h-11FFFFh
	43	64/32	Protection Group	240000h-24FFFFh	120000h-127FFFh
	44	64/32		250000h-25FFFFh	128000h-12FFFFh
	45	64/32		260000h-26FFFFh	130000h-137FFFh
	46	64/32		270000h-27FFFFh	138000h-13FFFFh
	47	64/32	Protection Group	280000h-28FFFFh	140000h-147FFFh
	48	64/32		290000h-29FFFFh	148000h-14FFFFh
	49	64/32		2A0000h-2AFFFFh	150000h-157FFFh
	50	64/32		2B0000h-2BFFFFh	158000h-15FFFFh
	51	64/32	Protection Group	2C0000h-2CFFFFh	160000h-167FFFh
	52	64/32		2D0000h-2DFFFFh	168000h-16FFFFh
	53	64/32		2E0000h-2EFFFFh	170000h-177FFFh
	54	64/32		2F0000h-2FFFFFh	178000h-17FFFFh
55	64/32	Protection Group	300000h-30FFFFh	180000h-187FFFh	
56	64/32		310000h-31FFFFh	188000h-18FFFFh	
57	64/32		320000h-32FFFFh	190000h-197FFFh	
58	64/32		330000h-33FFFFh	198000h-19FFFFh	

Table 34. Block Addresses and Protection Groups (continued)

Bank	Block	Size (kbytes/KWords)	Protection Block Group	(x8)	(x16)
Bank B	59	64/32	Protection Group	340000h-34FFFFh	1A0000h-1A7FFFh
	60	64/32		350000h-35FFFFh	1A8000h-1AFFFFh
	61	64/32		360000h-36FFFFh	1B0000h-1B7FFFh
	62	64/32		370000h-37FFFFh	1B8000h-1BFFFFh
	63	64/32	Protection Group	380000h-38FFFFh	1C0000h-1C7FFFh
	64	64/32		390000h-39FFFFh	1C8000h-1CFFFFh
	65	64/32		3A0000h-3AFFFFh	1D0000h-1D7FFFh
	66	64/32		3B0000h-3BFFFFh	1D8000h-1DFFFFh
	67	64/32	Protection Group	3C0000h-3CFFFFh	1E0000h-1E7FFFh
	68	64/32		3D0000h-3DFFFFh	1E8000h-1EFFFFh
	69	64/32		3E0000h-3EFFFFh	1F0000h-1F7FFFh
	70	64/32		3F0000h-3FFFFFh	1F8000h-1FFFFFh
	71	64/32	Protection Group	400000h-40FFFFh	200000h-207FFFh
	72	64/32		410000h-41FFFFh	208000h-20FFFFh
	73	64/32		420000h-42FFFFh	210000h-217FFFh
	74	64/32		430000h-43FFFFh	218000h-21FFFFh
	75	64/32	Protection Group	440000h-44FFFFh	220000h-227FFFh
	76	64/32		450000h-45FFFFh	228000h-22FFFFh
	77	64/32		460000h-46FFFFh	230000h-237FFFh
	78	64/32		470000h-47FFFFh	238000h-23FFFFh
79	64/32	Protection Group	480000h-48FFFFh	240000h-247FFFh	
80	64/32		490000h-49FFFFh	248000h-24FFFFh	
81	64/32		4A0000h-4AFFFFh	250000h-257FFFh	
82	64/32		4B0000h-4BFFFFh	258000h-25FFFFh	
83	64/32	Protection Group	4C0000h-4CFFFFh	260000h-267FFFh	
84	64/32		4D0000h-4DFFFFh	268000h-26FFFFh	
85	64/32		4E0000h-4EFFFFh	270000h-277FFFh	
86	64/32		4F0000h-4FFFFFh	278000h-27FFFFh	
87	64/32	Protection Group	500000h-50FFFFh	280000h-287FFFh	
88	64/32		510000h-51FFFFh	288000h-28FFFFh	
89	64/32		520000h-52FFFFh	290000h-297FFFh	
90	64/32		530000h-53FFFFh	298000h-29FFFFh	

Table 34. Block Addresses and Protection Groups (continued)

Bank	Block	Size (kbytes/KWords)	Protection Block Group	(x8)	(x16)
Bank B	91	64/32	Protection Group	540000h–54FFFFh	2A0000h–2A7FFFh
	92	64/32		550000h–55FFFFh	2A8000h–2AFFFFh
	93	64/32		560000h–56FFFFh	2B0000h–2B7FFFh
	94	64/32		570000h–57FFFFh	2B8000h–2BFFFFh
	95	64/32	Protection Group	580000h–58FFFFh	2C0000h–2C7FFFh
	96	64/32		590000h–59FFFFh	2C8000h–2CFFFFh
	97	64/32		5A0000h–5AFFFFh	2D0000h–2D7FFFh
	98	64/32		5B0000h–5BFFFFh	2D8000h–2DFFFFh
	99	64/32	Protection Group	5C0000h–5CFFFFh	2E0000h–2E7FFFh
	100	64/32		5D0000h–5DFFFFh	2E8000h–2EFFFFh
	101	64/32		5E0000h–5EFFFFh	2F0000h–2F7FFFh
	102	64/32		5F0000h–5FFFFFh	2F8000h–2FFFFFh
	103	64/32	Protection Group	600000h–60FFFFh	300000h–307FFFh
	104	64/32		610000h–61FFFFh	308000h–30FFFFh
	105	64/32		620000h–62FFFFh	310000h–317FFFh
	106	64/32		630000h–63FFFFh	318000h–31FFFFh
	107	64/32	Protection Group	640000h–64FFFFh	320000h–327FFFh
	108	64/32		650000h–65FFFFh	328000h–32FFFFh
	109	64/32		660000h–66FFFFh	330000h–337FFFh
	110	64/32		670000h–67FFFFh	338000h–33FFFFh
	111	64/32	Protection Group	680000h–68FFFFh	340000h–347FFFh
	112	64/32		690000h–69FFFFh	348000h–34FFFFh
113	64/32	6A0000h–6AFFFFh		350000h–357FFFh	
114	64/32	6B0000h–6BFFFFh		358000h–35FFFFh	
115	64/32	Protection Group	6C0000h–6CFFFFh	360000h–367FFFh	
116	64/32		6D0000h–6DFFFFh	368000h–36FFFFh	
117	64/32		6E0000h–6EFFFFh	370000h–377FFFh	
118	64/32		6F0000h–6FFFFFh	378000h–37FFFFh	
119	64/32	Protection Group	700000h–70FFFFh	380000h–387FFFh	
120	64/32		710000h–71FFFFh	388000h–38FFFFh	
121	64/32		720000h–72FFFFh	390000h–397FFFh	
122	64/32		730000h–73FFFFh	398000h–39FFFFh	

Table 34. Block Addresses and Protection Groups (continued)

Bank	Block	Size (kbytes/KWords)	Protection Block Group	(x8)	(x16)
Bank B	123	64/32	Protection Group	740000h–74FFFFh	3A0000h–3A7FFFh
	124	64/32		750000h–75FFFFh	3A8000h–3AFFFFh
	125	64/32		760000h–76FFFFh	3B0000h–3B7FFFh
	126	64/32		770000h–77FFFFh	3B8000h–3BFFFFh
	127	64/32	Protection Group	780000h–78FFFFh	3C0000h–3C7FFFh
	128	64/32		790000h–79FFFFh	3C8000h–3CFFFFh
	129	64/32		7A0000h–7AFFFFh	3D0000h–3D7FFFh
	130	64/32		7B0000h–7BFFFFh	3D8000h–3DFFFFh
	131	64/32	Protection Group	7C0000h–7CFFFFh	3E0000h–3E7FFFh
	132	64/32		7D0000h–7DFFFFh	3E8000h–3EFFFFh
	133	64/32		7E0000h–7EFFFFh	3F0000h–3F7FFFh
	134	64/32		7F0000h–7FFFFFFh	3F8000h–3FFFFFFh
Bank C	135	64/32	Protection Group	800000h–80FFFFh	400000h–407FFFh
	136	64/32		810000h–81FFFFh	408000h–40FFFFh
	137	64/32		820000h–82FFFFh	410000h–417FFFh
	138	64/32		830000h–83FFFFh	418000h–41FFFFh
	139	64/32	Protection Group	840000h–84FFFFh	420000h–427FFFh
	140	64/32		850000h–85FFFFh	428000h–42FFFFh
	141	64/32		860000h–86FFFFh	430000h–437FFFh
	142	64/32		870000h–87FFFFh	438000h–43FFFFh
	143	64/32	Protection Group	880000h–88FFFFh	440000h–447FFFh
	144	64/32		890000h–89FFFFh	448000h–44FFFFh
	145	64/32		8A0000h–8AFFFFh	450000h–457FFFh
	146	64/32		8B0000h–8BFFFFh	458000h–45FFFFh
	147	64/32	Protection Group	8C0000h–8CFFFFh	460000h–467FFFh
	148	64/32		8D0000h–8DFFFFh	468000h–46FFFFh
	149	64/32		8E0000h–8EFFFFh	470000h–477FFFh
	150	64/32		8F0000h–8FFFFFFh	478000h–47FFFFh
	151	64/32	Protection Group	900000h–90FFFFh	480000h–487FFFh
152	64/32	910000h–91FFFFh		488000h–48FFFFh	
153	64/32	920000h–92FFFFh		490000h–497FFFh	
154	64/32	930000h–93FFFFh		498000h–49FFFFh	

Table 34. Block Addresses and Protection Groups (continued)

Bank	Block	Size (kbytes/KWords)	Protection Block Group	(x8)	(x16)
Bank C	155	64/32	Protection Group	940000h–94FFFFh	4A0000h–4A7FFFh
	156	64/32		950000h–95FFFFh	4A8000h–4AFFFFh
	157	64/32		960000h–96FFFFh	4B0000h–4B7FFFh
	158	64/32		970000h–97FFFFh	4B8000h–4BFFFFh
	159	64/32	Protection Group	980000h–98FFFFh	4C0000h–4C7FFFh
	160	64/32		990000h–99FFFFh	4C8000h–4CFFFFh
	161	64/32		9A0000h–9AFFFFh	4D0000h–4D7FFFh
	162	64/32		9B0000h–9BFFFFh	4D8000h–4DFFFFh
	163	64/32	Protection Group	9C0000h–9CFFFFh	4E0000h–4E7FFFh
	164	64/32		9D0000h–9DFFFFh	4E8000h–4EFFFFh
	165	64/32		9E0000h–9EFFFFh	4F0000h–4F7FFFh
	166	64/32		9F0000h–9FFFFFFh	4F8000h–4FFFFFFh
	167	64/32	Protection Group	A00000h–A0FFFFh	500000h–507FFFh
	168	64/32		A10000h–A1FFFFh	508000h–50FFFFh
	169	64/32		A20000h–A2FFFFh	510000h–517FFFh
	170	64/32		A30000h–A3FFFFh	518000h–51FFFFh
	171	64/32	Protection Group	A40000h–A4FFFFh	520000h–527FFFh
	172	64/32		A50000h–A5FFFFh	528000h–52FFFFh
	173	64/32		A60000h–A6FFFFh	530000h–537FFFh
	174	64/32		A70000h–A7FFFFh	538000h–53FFFFh
175	64/32	Protection Group	A80000h–A8FFFFh	540000h–547FFFh	
176	64/32		A90000h–A9FFFFh	548000h–54FFFFh	
177	64/32		AA0000h–AAFFFFh	550000h–557FFFh	
178	64/32		AB0000h–ABFFFFh	558000h–55FFFFh	
179	64/32	Protection Group	AC0000h–ACFFFFh	560000h–567FFFh	
180	64/32		AD0000h–ADFFFFh	568000h–56FFFFh	
181	64/32		AE0000h–AEFFFFh	570000h–577FFFh	
182	64/32		AF0000h–AFFFFFFh	578000h–57FFFFh	
183	64/32	Protection Group	B00000h–B0FFFFh	580000h–587FFFh	
184	64/32		B10000h–B1FFFFh	588000h–58FFFFh	
185	64/32		B20000h–B2FFFFh	590000h–597FFFh	
186	64/32		B30000h–B3FFFFh	598000h–59FFFFh	

Table 34. Block Addresses and Protection Groups (continued)

Bank	Block	Size (kbytes/KWords)	Protection Block Group	(x8)	(x16)
Bank C	187	64/32	Protection Group	B40000h–B4FFFFh	5A0000h–5A7FFFh
	188	64/32		B50000h–B5FFFFh	5A8000h–5AFFFFh
	189	64/32		B60000h–B6FFFFh	5B0000h–5B7FFFh
	190	64/32		B70000h–B7FFFFh	5B8000h–5BFFFFh
	191	64/32	Protection Group	B80000h–B8FFFFh	5C0000h–5C7FFFh
	192	64/32		B90000h–B9FFFFh	5C8000h–5CFFFFh
	193	64/32		BA0000h–BAFFFFh	5D0000h–5D7FFFh
	194	64/32		BB0000h–BBFFFFh	5D8000h–5DFFFFh
	195	64/32	Protection Group	BC0000h–BCFFFFh	5E0000h–5E7FFFh
	196	64/32		BD0000h–BDFFFFh	5E8000h–5EFFFFh
	197	64/32		BE0000h–BEFFFFh	5F0000h–5F7FFFh
	198	64/32		BF0000h–BFFFFFh	5F8000h–5FFFFFh
	199	64/32	Protection Group	C00000h–C0FFFFh	600000h–607FFFh
	200	64/32		C10000h–C1FFFFh	608000h–60FFFFh
	201	64/32		C20000h–C2FFFFh	610000h–617FFFh
	202	64/32		C30000h–C3FFFFh	618000h–61FFFFh
	203	64/32	Protection Group	C40000h–C4FFFFh	620000h–627FFFh
	204	64/32		C50000h–C5FFFFh	628000h–62FFFFh
	205	64/32		C60000h–C6FFFFh	630000h–637FFFh
	206	64/32		C70000h–C7FFFFh	638000h–63FFFFh
207	64/32	Protection Group	C80000h–C8FFFFh	640000h–647FFFh	
208	64/32		C90000h–C9FFFFh	648000h–64FFFFh	
209	64/32		CA0000h–CAFFFFh	650000h–657FFFh	
210	64/32		CB0000h–CBFFFFh	658000h–65FFFFh	
211	64/32	Protection Group	CC0000h–CCFFFFh	660000h–667FFFh	
212	64/32		CD0000h–CDFFFFh	668000h–66FFFFh	
213	64/32		CE0000h–CEFFFFh	670000h–677FFFh	
214	64/32		CF0000h–CFFFFFh	678000h–67FFFFh	
215	64/32	Protection Group	D00000h–D0FFFFh	680000h–687FFFh	
216	64/32		D10000h–D1FFFFh	688000h–68FFFFh	
217	64/32		D20000h–D2FFFFh	690000h–697FFFh	
218	64/32		D30000h–D3FFFFh	698000h–69FFFFh	

Table 34. Block Addresses and Protection Groups (continued)

Bank	Block	Size (kbytes/KWords)	Protection Block Group	(x8)	(x16)
Bank C	219	64/32	Protection Group	D40000h–D4FFFFh	6A0000h–6A7FFFh
	220	64/32		D50000h–D5FFFFh	6A8000h–6AFFFFh
	221	64/32		D60000h–D6FFFFh	6B0000h–6B7FFFh
	222	64/32		D70000h–D7FFFFh	6B8000h–6BFFFFh
	223	64/32	Protection Group	D80000h–D8FFFFh	6C0000h–6C7FFFh
	224	64/32		D90000h–D9FFFFh	6C8000h–6CFFFFh
	225	64/32		DA0000h–DAFFFFh	6D0000h–6D7FFFh
	226	64/32		DB0000h–DBFFFFh	6D8000h–6DFFFFh
	227	64/32	Protection Group	DC0000h–DCFFFFh	6E0000h–6E7FFFh
	228	64/32		DD0000h–DDFFFFh	6E8000h–6EFFFFh
	229	64/32		DE0000h–DEFFFFh	6F0000h–6F7FFFh
	230	64/32		DF0000h–DFFFFFh	6F8000h–6FFFFFh
Bank D	231	64/32	Protection Group	E00000h–E0FFFFh	700000h–707FFFh
	232	64/32		E10000h–E1FFFFh	708000h–70FFFFh
	233	64/32		E20000h–E2FFFFh	710000h–717FFFh
	234	64/32		E30000h–E3FFFFh	718000h–71FFFFh
	235	64/32	Protection Group	E40000h–E4FFFFh	720000h–727FFFh
	236	64/32		E50000h–E5FFFFh	728000h–72FFFFh
	237	64/32		E60000h–E6FFFFh	730000h–737FFFh
	238	64/32		E70000h–E7FFFFh	738000h–73FFFFh
	239	64/32	Protection Group	E80000h–E8FFFFh	740000h–747FFFh
	240	64/32		E90000h–E9FFFFh	748000h–74FFFFh
	241	64/32		EA0000h–EAFFFFh	750000h–757FFFh
	242	64/32		EB0000h–EBFFFFh	758000h–75FFFFh
	243	64/32	Protection Group	EC0000h–ECFFFFh	760000h–767FFFh
	244	64/32		ED0000h–EDFFFFh	768000h–76FFFFh
	245	64/32		EE0000h–EEFFFFh	770000h–777FFFh
	246	64/32		EF0000h–EFFFFFh	778000h–77FFFFh
	247	64/32	Protection Group	F00000h–F0FFFFh	780000h–787FFFh
248	64/32	F10000h–F1FFFFh		788000h–78FFFFh	
249	64/32	F20000h–F2FFFFh		790000h–797FFFh	
250	64/32	F30000h–F3FFFFh		798000h–79FFFFh	

Table 34. Block Addresses and Protection Groups (continued)

Bank	Block	Size (kbytes/KWords)	Protection Block Group	(x8)	(x16)
Bank D	251	64/32	Protection Group	F40000h-F4FFFFh	7A0000h-7A7FFFh
	252	64/32		F50000h-F5FFFFh	7A8000h-7AFFFFh
	253	64/32		F60000h-F6FFFFh	7B0000h-7B7FFFh
	254	64/32		F70000h-F7FFFFh	7B8000h-7BFFFFh
	255	64/32	Protection Group	F80000h-F8FFFFh	7C0000h-7C7FFFh
	256	64/32		F90000h-F9FFFFh	7C8000h-7CFFFFh
	257	64/32		FA0000h-FAFFFFh	7D0000h-7D7FFFh
	258	64/32		FB0000h-FBFFFFh	7D8000h-7DFFFFh
	259	64/32	Protection Group	FC0000h-FCFFFFh	7E0000h-7E7FFFh
	260	64/32		FD0000h-FDFFFFh	7E8000h-7EFFFFh
	261	64/32		FE0000h-FEFFFFh	7F0000h-7F7FFFh
	262	8/4	Protection Group	FF0000h-FF1FFFh ⁽¹⁾	7F8000h-7F8FFFh ⁽¹⁾
	263	8/4	Protection Group	FF2000h-FF3FFFh ⁽¹⁾	7F9000h-7F9FFFh ⁽¹⁾
	264	8/4	Protection Group	FF4000h-FF5FFFh ⁽¹⁾	7FA000h-7FAFFFh ⁽¹⁾
	265	8/4	Protection Group	FF6000h-FF7FFFh ⁽¹⁾	7FB000h-7FBFFFh ⁽¹⁾
	266	8/4	Protection Group	FF8000h-FF9FFFh ⁽¹⁾	7FC000h-7FCFFFh ⁽¹⁾
	267	8/4	Protection Group	FFA000h-FFBFFFh ⁽¹⁾	7FD000h-7FDFFFh ⁽¹⁾
	268	8/4	Protection Group	FFC000h-FFDFFFh ⁽¹⁾	7FE000h-7FEFFFh ⁽¹⁾
269	8/4	Protection Group	FFE000h-FFFFFh ⁽¹⁾	7FF000h-7FFFFFh ⁽¹⁾	

1. Parameter Blocks.

Appendix B Common Flash Interface (CFI)

The Common Flash Interface is a JEDEC approved, standardized data structure that can be read from the Flash memory device. It allows a system software to query the device to determine various electrical and timing parameters, density information and functions supported by the memory. The system can interface easily with the device, enabling the software to upgrade itself when necessary.

When the Read CFI Query command is issued the addressed bank enters Read CFI Query mode and read operations in the same bank (A22-A19) output the CFI data. *Table 35, Table 36, Table 37, Table 38, Table 39* and *Table 40* show the addresses (A-1, A0-A10) used to retrieve the data.

The CFI data structure also contains a security area where a 64 bit unique security number is written (see *Table 40: Security Code Area*). This area can be accessed only in Read mode by the final user. It is impossible to change the security number after it has been written by Numonyx.

Table 35. Query Structure Overview⁽¹⁾

Address		Sub-section Name	Description
x16	x8		
10h	20h	CFI Query Identification String	Command set ID and algorithm data offset
1Bh	36h	System Interface Information	Device timing & voltage information
27h	4Eh	Device Geometry Definition	Flash device layout
40h	80h	Primary Algorithm-specific Extended Query table	Additional information specific to the Primary Algorithm (optional)
61h	C2h	Security Code Area	64 bit unique device number

1. Query data are always presented on the lowest order data outputs.

Table 36. CFI Query Identification String⁽¹⁾

Address		Data	Description	Value
x16	x8			
10h	20h	0051h	Query Unique ASCII String "QRY"	"Q"
11h	22h	0052h		"R"
12h	24h	0059h		"Y"
13h	26h	0002h	Primary Algorithm Command Set and Control Interface ID code 16 bit ID code defining a specific algorithm	AMD Compatible
14h	28h	0000h		
15h	2Ah	0040h	Address for Primary Algorithm extended Query table (see <i>Table 39</i>)	P = 40h
16h	2Ch	0000h		
17h	2Eh	0000h	Alternate Vendor Command Set and Control Interface ID Code second vendor - specified algorithm supported	NA
18h	30h	0000h		
19h	32h	0000h	Address for Alternate Algorithm extended Query table	NA
1Ah	34h	0000h		

1. Query data are always presented on the lowest order data outputs (DQ7-DQ0) only. DQ8-DQ15 are '0'.

Table 37. CFI Query System Interface information⁽¹⁾

Address		Data	Description	Value
x16	x8			
1Bh	36h	0027h	V _{CC} Logic Supply Minimum Program/Erase voltage bit 7 to 4BCD value in volts bit 3 to 0BCD value in 100mV	2.7V
1Ch	38h	0036h	V _{CC} Logic Supply Maximum Program/Erase voltage bit 7 to 4BCD value in volts bit 3 to 0BCD value in 100mV	3.6V
1Dh	3Ah	00B5h	V _{PP} [Programming] Supply Minimum Program/Erase voltage bit 7 to 4HEX value in volts bit 3 to 0BCD value in 100mV	11.5V
1Eh	3Ch	00C5h	V _{PP} [Programming] Supply Maximum Program/Erase voltage bit 7 to 4HEX value in volts bit 3 to 0BCD value in 10mV	12.5V
1Fh	3Eh	0004h	Typical timeout per single byte/Word program = 2 ⁿ μs	16μs
20h	40h	0000h	Typical timeout for minimum size write buffer program = 2 ⁿ μs	NA
21h	42h	0009h	Typical timeout per individual block erase = 2 ⁿ ms	512ms
22h	44h	0000h	Typical timeout for full Chip Erase = 2 ⁿ ms	NA
23h	46h	0005h	Maximum timeout for byte/Word program = 2 ⁿ times typical	512μs
24h	48h	0000h	Maximum timeout for write buffer program = 2 ⁿ times typical	NA
25h	4Ah	0004h	Maximum timeout per individual block erase = 2 ⁿ times typical	8s
26h	4Ch	0000h	Maximum timeout for Chip Erase = 2 ⁿ times typical	NA

1. The values given in the above table are valid for both packages.

Table 38. Device Geometry Definition⁽¹⁾

Address		Data	Description	Value
x16	x8			
27h	4Eh	0018h	Device Size = 2 ⁿ in number of bytes	16 Mbytes
28h	50h	0001h	TBGA64 (x16 only)	Flash Device Interface Code description
		0002h	TSOP56 (x8/x16)	
29h	52h	0000h	Both Packages	
2Ah	54h	0006h	Maximum number of bytes in Multiple-byte program or Page= 2 ⁿ	64
2Bh	56h	0000h		
2Ch	58h	0003h	Number of Erase Block Regions ⁽¹⁾ . It specifies the number of regions containing contiguous Erase Blocks of the same size.	3
2Dh	5Ah	0007h	Erase Block Region 1 Information	8
2Eh	5Ch	0000h	Number of Erase Blocks of identical size = 0007h+1	
2Fh	5Eh	0020h	Erase Block Region 1 Information	8 Kbytes
30h	60h	0000h	Block size in Region 1 = 0020h * 256 byte	
31h	62h	00FDh	Erase Block Region 2 Information	254
32h	64h	0000h	Number of Erase Blocks of identical size = 00FDh+1	
33h	66h	0000h	Erase Block Region 2 Information	64 Kbytes
34h	68h	0001h	Block size in Region 2 = 0100h * 256 byte	
35h	6Ah	0007h	Erase Block Region 3 information	8
36h	6Ch	0000h	Number of Erase Blocks of identical size = 0007h + 1	
37h	6Eh	0020h	Erase Block Region 3 information	8 Kbytes
38h	70h	0000h	Block size in region 3 = 0020h * 256 bytes	
39h	72h	0000h	Erase Block Region 4 information	0
3Ah	74h	0000h		
3Bh	76h	0000h		
3Ch	78h	0000h		

1. Erase Block Region 1 corresponds to addresses 000000h to 007FFFh; Erase block Region 2 corresponds to addresses 008000h to 3F7FFFh and Erase Block Region 3 corresponds to addresses 3F8000h to 3FFFFFFh.

Table 39. Primary Algorithm-Specific Extended Query table ⁽¹⁾

Address		Data	Description	Value
x16	x8			
40h	80h	0050h	Primary Algorithm Extended Query table unique ASCII string "PRI"	"P"
41h	82h	0052h		"R"
42h	84h	0049h		"I"
43h	86h	0031h	Major version number, ASCII	"1"
44h	88h	0033h	Minor version number, ASCII	"3"
45h	8Ah	000Ch	Address Sensitive Unlock (bits 1 to 0) 00 = required, 01 = not required Silicon Revision Number (bits 7 to 2)	Yes
46h	8Ch	0002h	Erase Suspend 00 = not supported, 01 = Read only, 02 = Read and Write	2
47h	8Eh	0001h	Block Protection 00 = not supported, x = number of sectors in per group	1
48h	90h	0001h	Temporary Block Unprotect 00 = not supported, 01 = supported	Yes
49h	92h	0006h	Block Protect /Unprotect 06 = M29DW128F	6
4Ah	94h	00E7	Simultaneous Operations, x = number of blocks (excluding Bank A)	231
4Bh	96h	0000h	Burst Mode, 00 = not supported, 01 = supported	No
4Ch	98h	0002h	Page Mode, 00 = not supported, 02 = 8-Word page	Yes
4Dh	9Ah	00B5h	V _{PP} Supply Minimum Program/Erase voltage bit 7 to 4 HEX value in volts bit 3 to 0 BCD value in 100mV	11.5V
4Eh	9Ch	00C5h	V _{PP} Supply Maximum Program/Erase voltage bit 7 to 4 HEX value in volts bit 3 to 0 BCD value in 100mV	12.5V
4Fh	9Eh	0001h	Top/Bottom Boot Block Flag 00h = Uniform device 01h = 8 x8 Kbyte Blocks or 4KWords, Top and Bottom Boot with Write Protect 02h = Bottom boot device 03h = Top Boot Device 04h = Both Top and Bottom	T/B
50h	A0h	0001h	Program Suspend, 00 = not supported, 01 = supported	Yes
57h	A Eh	0004h	Bank Organization, 00 = data at 4Ah is zero X = number of banks	4
58h	B0h	0027h	Bank A information X = number of blocks in Bank A	39

Table 39. Primary Algorithm-Specific Extended Query table (continued)⁽¹⁾

Address		Data	Description	Value
x16	x8			
59h	B2h	0060h	Bank B information X = number of blocks in Bank B	96
5Ah	B4h	0060h	Bank C information X = number of blocks in Bank C	96
5Bh	B6h	0027h	Bank D information X = number of blocks in Bank D	39

1. The values given in the above table are valid for both packages.

Table 40. Security Code Area

Address		Data	Description
x16	x8		
61h	C3h, C2h	XXXX	64 bit: unique device number
62h	C5h, C4h	XXXX	
63h	C7h, C6h	XXXX	
64h	C9h, C8h	XXXX	

Appendix C Extended Memory Block

The M29DW128F has an extra block, the Extended Block, that can be accessed using a dedicated command.

This Extended Block is 128 Words in x16 mode and 256 bytes in x8 mode. It is used as a security block (to provide a permanent security identification number) or to store additional information.

The Extended Block is divided into two memory areas of 64 Words each:

- The first one is Factory Locked.
- The second one is Customer Lockable. It is up to the customer to protect it from program operations. Its status is indicated by bit DQ6 and DQ7. When DQ7 is set to '1' and DQ6 to '0', it indicates that this second memory area is Customer Lockable. When DQ7 and DQ6 are both set to '1', it indicates that the second part of the Extended Block is Customer Locked and protected from program operations. Bit DQ7 being permanently locked to either '1' or '0' is another security feature which ensures that a customer lockable device cannot be used instead of a factory locked one.

Bits DQ6 and DQ7 are the most significant bits in the Extended Block Protection Indicator and a specific procedure must be followed to read it. See "*Section 3.6.2: Verify Extended Block Protection Indicator*" and *Table 5* and *Table 8*, Block Protection, for details of how to read bit DQ7.

The Extended Block can only be accessed when the device is in Extended Block mode. For details of how the Extended Block mode is entered and exited, refer to the *Section 6.1.11: Program command* and *Section 6.3.2: Exit Extended Block command* paragraphs, and to *Table 15* and *Table 16*, Block Protection Commands.

C.1 Factory Locked Section of the Extended Block

The first section of The Extended Block is permanently protected from program operations and cannot be unprotected. The Random Number, Electronic Serial Number (ESN) and Security Identification Number (see *Table 41: Extended Block Address and Data*) are written in this section in the factory.

C.2 Customer Lockable Section of the Extended Block

The device is delivered with the second section of the Extended Block "Customer Lockable": bits DQ7 and DQ6 are set to '1' and '0' respectively. It is up to the customer to program and protect this section of the Extended Block but care must be taken because the protection is not reversible.

There are three ways of protecting this section:

- Issue the Enter Extended Block command to place the device in Extended Block mode, then use the In-System Technique with \overline{RP} either at V_{IH} or at V_{ID} . Refer to *Section D.2: In-System technique* in *Appendix D: High Voltage Block Protection*, and to the corresponding flowcharts *Figure 25* and *Figure 26* for a detailed explanation of the technique).
- Issue the Enter Extended Block command to place the device in Extended Block mode, then use the Programmer Technique. Refer to *Section D.1: Programmer technique* in *Appendix D: High Voltage Block Protection*, and to the corresponding flowcharts *Figure 23* and *Figure 24* for a detailed explanation of the technique).
- Issue a Set Extended Block Protection bit command to program the Extended Block Protection bit to '1' thus preventing the second section of the Extended Block from being programmed.

Bit DQ6 of the Extended Block Protection Indicator is automatically set to '1' to indicate that the second section of the Extended Block is Customer Locked.

Once the Extended Block is programmed and protected, the Exit Extended Block command must be issued to exit the Extended Block mode and return the device to Read mode.

Table 41. Extended Block Address and Data

Device	Address ⁽¹⁾		Data	
	x8	x16	Factory Locked	Customer Lockable
M29DW128F	000000h-00007Fh	000000h-00003Fh	Random Number, ESN ⁽²⁾ , Security Identification Number	Unavailable
	000080h-0000FFh	000040h-00007Fh	Unavailable	Determined by Customer

1. See *Table 34: Block Addresses and Protection Groups*.

2. ESN = Electronic Serial Number.

Appendix D High Voltage Block Protection

The High Voltage Block Protection can be used to prevent any operation from modifying the data stored in the memory. The blocks are protected in groups, refer to *Appendix A, Table 34* for details of the Protection Groups. Once protected, Program and Erase operations within the protected group fail to change the data.

There are three techniques that can be used to control Block Protection, these are the Programmer technique, the In-System technique and Temporary Unprotection. Temporary Unprotection is controlled by the Reset/Block Temporary Unprotection pin, \overline{RP} ; this is described in the Signal Descriptions section.

To protect the Extended Block issue the Enter Extended Block command and then use either the Programmer or In-System technique. Once protected issue the Exit Extended Block command to return to read mode. The Extended Block protection is irreversible, once protected the protection cannot be undone.

D.1 Programmer technique

The Programmer technique uses high (V_{ID}) voltage levels on some of the bus pins. These cannot be achieved using a standard microprocessor bus, therefore the technique is recommended only for use in Programming Equipment.

To protect a group of blocks follow the flowchart in *Figure 23: Programmer equipment Group Protect flowchart*. To unprotect the whole chip it is necessary to protect all of the groups first, then all groups can be unprotected at the same time. To unprotect the chip follow *Figure 24: Programmer equipment Chip Unprotect flowchart*. *Table 42: Programmer technique Bus operations, 8-bit or 16-bit mode*, gives a summary of each operation.

The timing on these flowcharts is critical. Care should be taken to ensure that, where a pause is specified, it is followed as closely as possible. Do not abort the procedure before reaching the end. Chip Unprotect can take several seconds and a user message should be provided to show that the operation is progressing.

D.2 In-System technique

The In-System technique requires a high voltage level on the Reset/Blocks Temporary Unprotect pin, \overline{RP} ⁽¹⁾. This can be achieved without violating the maximum ratings of the components on the microprocessor bus, therefore this technique is suitable for use after the memory has been fitted to the system.

To protect a group of blocks follow the flowchart in *Figure 25: In-System equipment Group Protect flowchart*. To unprotect the whole chip it is necessary to protect all of the groups first, then all the groups can be unprotected at the same time. To unprotect the chip follow *Figure 26: In-System equipment Chip Unprotect flowchart*.

The timing on these flowcharts is critical. Care should be taken to ensure that, where a pause is specified, it is followed as closely as possible. Do not allow the microprocessor to service interrupts that will upset the timing and do not abort the procedure before reaching the end. Chip Unprotect can take several seconds and a user message should be provided to show that the operation is progressing.

Note: \overline{RP} can be either at V_{IH} or at V_{ID} when using the In-System Technique to protect the Extended Block.

Table 42. Programmer technique Bus operations, 8-bit or 16-bit mode

Operation	\overline{E}	\overline{G}	\overline{W}	Address Inputs A0-A22	Data Inputs/Outputs DQ15A-1, DQ14-DQ0
Block (Group) Protect ⁽¹⁾	V_{IL}	V_{ID}	V_{IL} Pulse	A9 = V_{ID} , A12-A22 Block Address Others = X	X
Chip Unprotect	V_{ID}	V_{ID}	V_{IL} Pulse	A6 = V_{IH} , A9 = V_{ID} , A12 = V_{IH} , A15 = V_{IH} Others = X	X
Block (Group) Protect Verify	V_{IL}	V_{IL}	V_{IH}	A0 = V_{IL} , A1 = V_{IH} , A2-A7 = V_{IL} , A9 = V_{ID} , A12-A22 Block Address Others = X	Pass = xx01h Retry = xx00h.
Block (Group) Unprotect Verify	V_{IL}	V_{IL}	V_{IH}	A0 = V_{IL} , A1 = V_{IH} , A2 -A5 = V_{IL} , A6 = V_{IH} , A7 = V_{IL} , A9 = V_{ID} , A12-A22 Block Address Others = X	Pass = xx00h Retry = xx01h.

1. Block Protection Groups are shown in *Appendix A, Table 34*.

Appendix E Flowcharts

Figure 23. Programmer equipment Group Protect flowchart

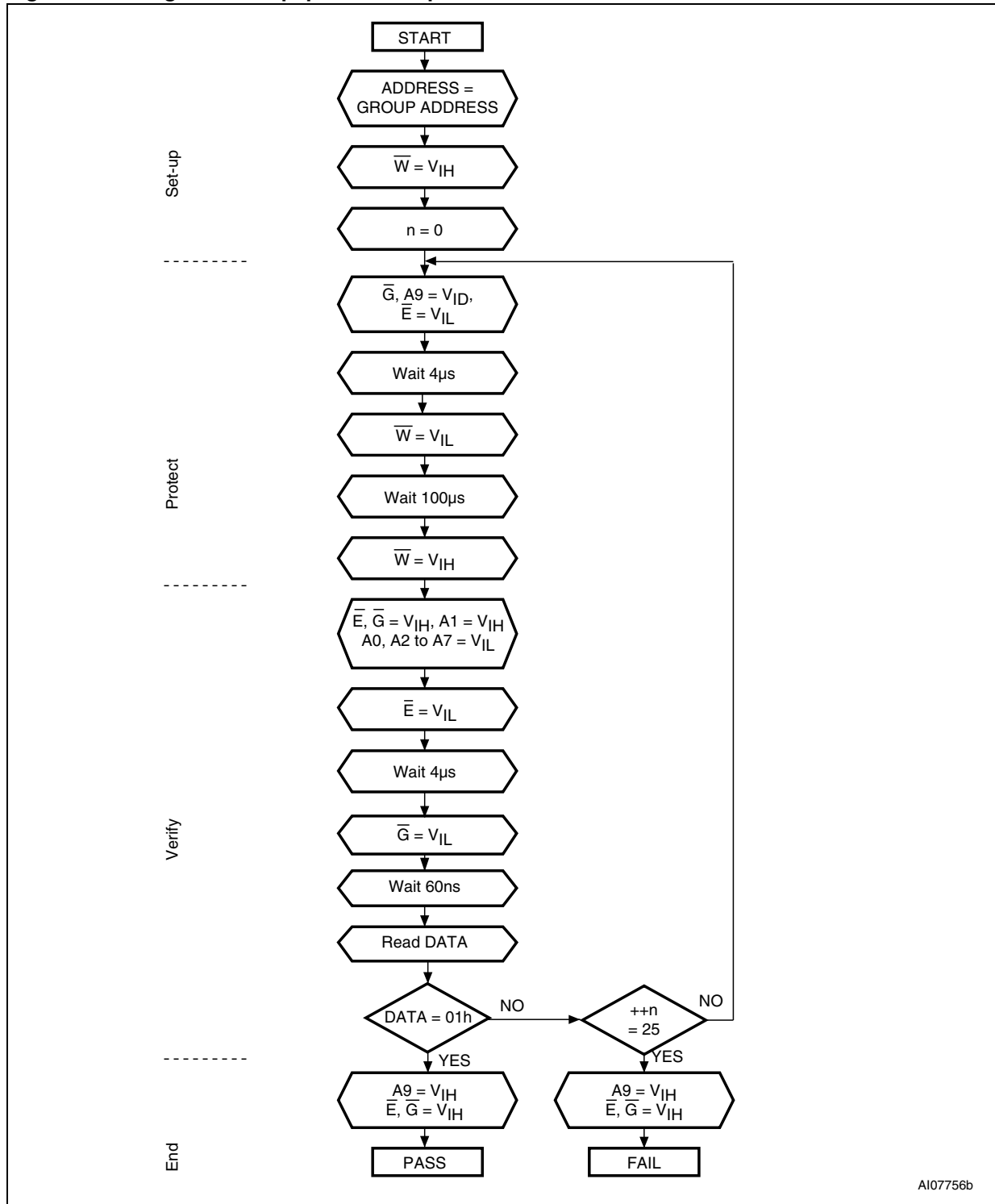

AI07756b

1. Block Protection Groups are shown in Appendix A, Table 34.

Figure 24. Programmer equipment Chip Unprotect flowchart

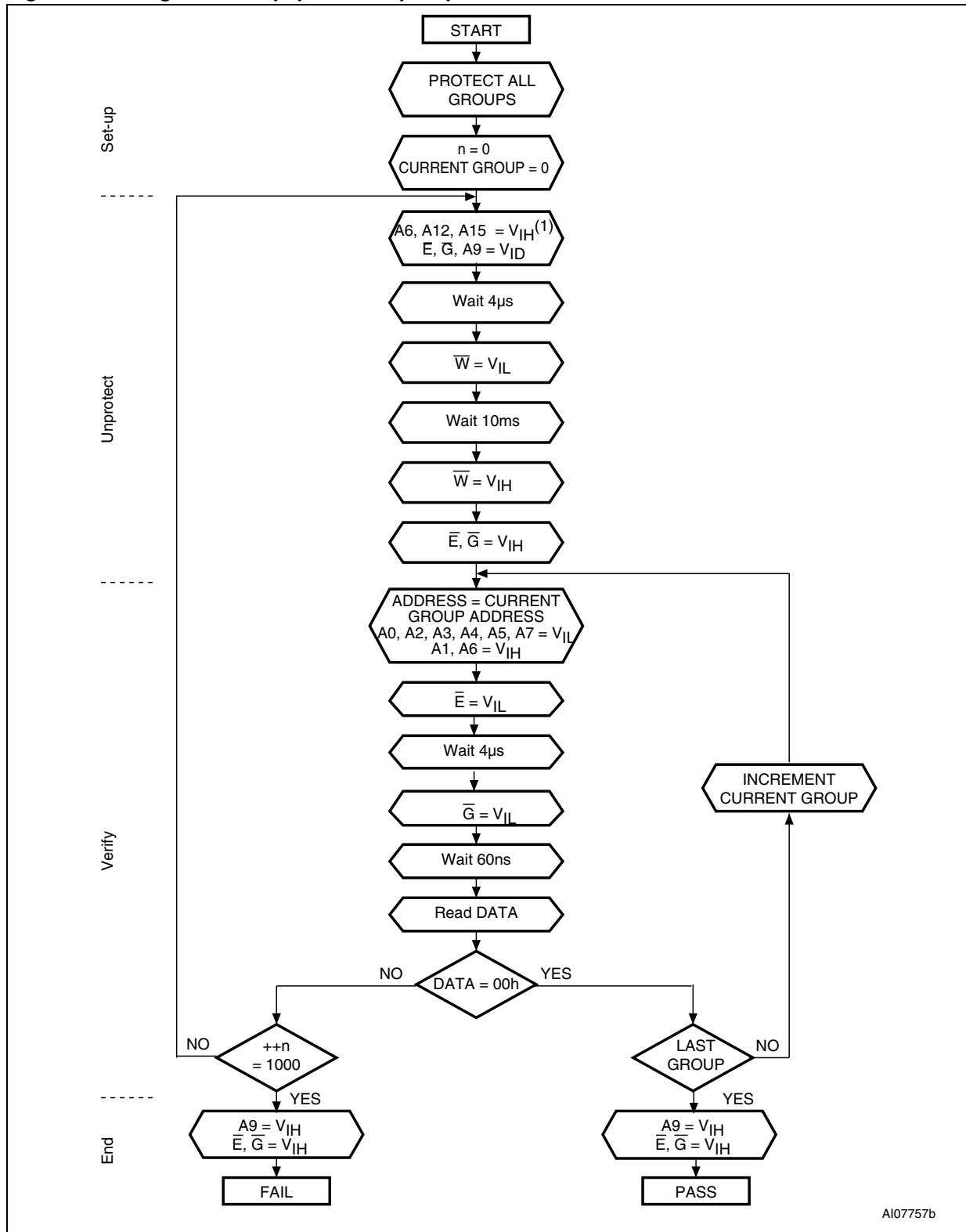

AI07757b

1. Block Protection Groups are shown in Appendix A, Table 34.

Figure 25. In-System equipment Group Protect flowchart

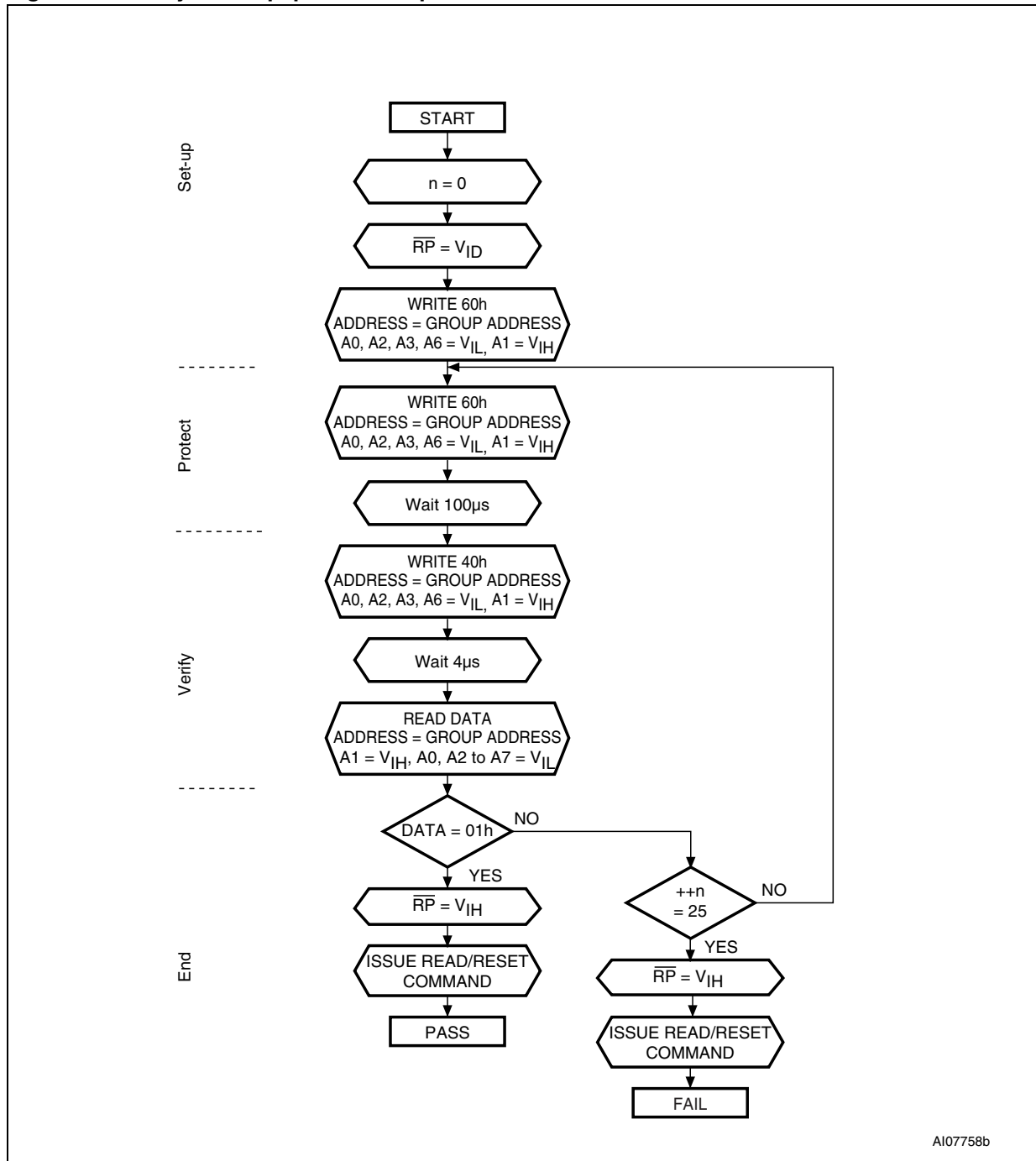

AI07758b

1. Block Protection Groups are shown in *Appendix A, Table 34*.
2. \overline{RP} can be either at V_{IH} or at V_{ID} when using the In-System Technique to protect the Extended Block.

Figure 26. In-System equipment Chip Unprotect flowchart

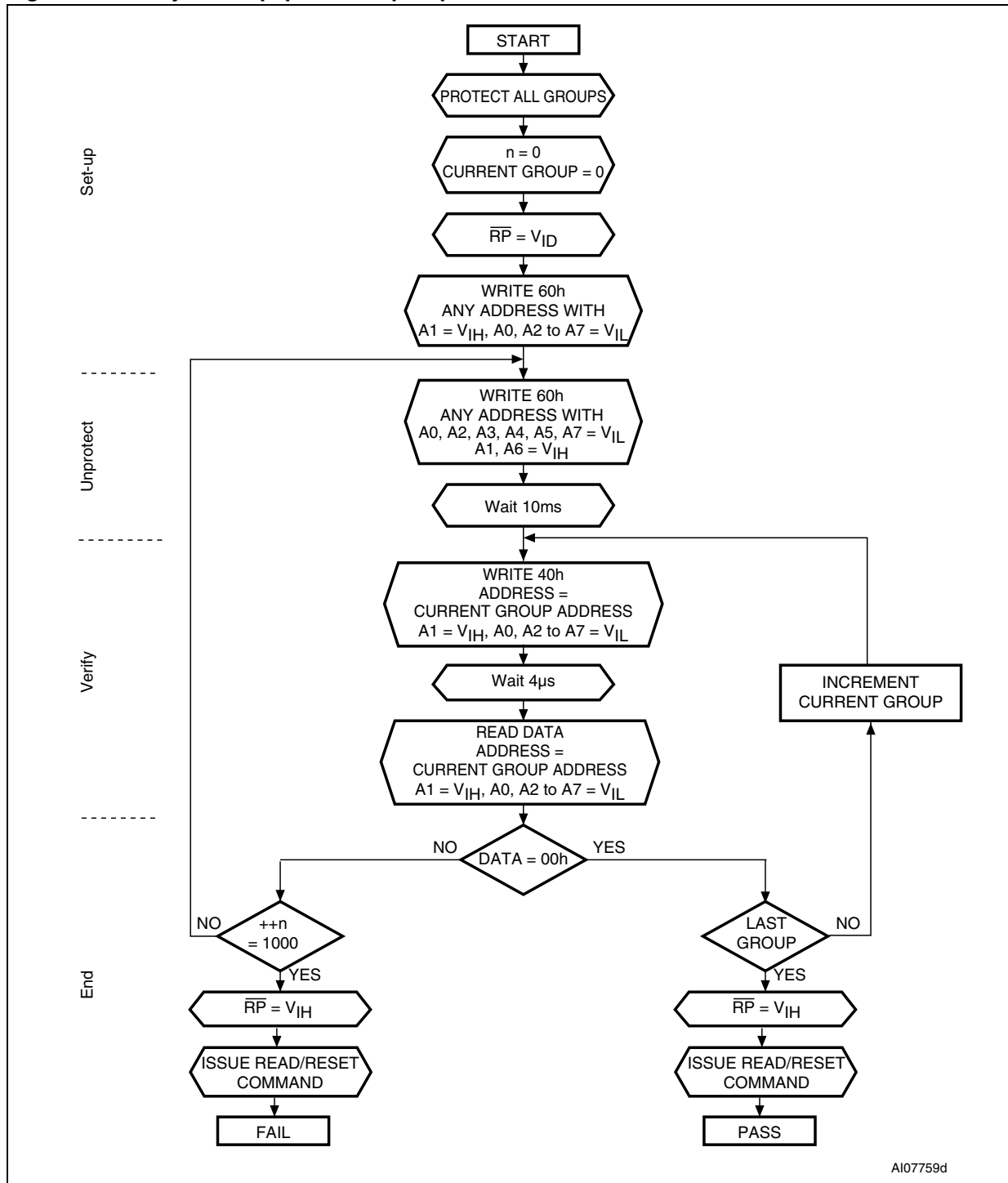

AI07759d

1. Block Protection Groups are shown in Appendix A, Table 34.

Figure 27. Write to Buffer and Program flowchart and Pseudo Code

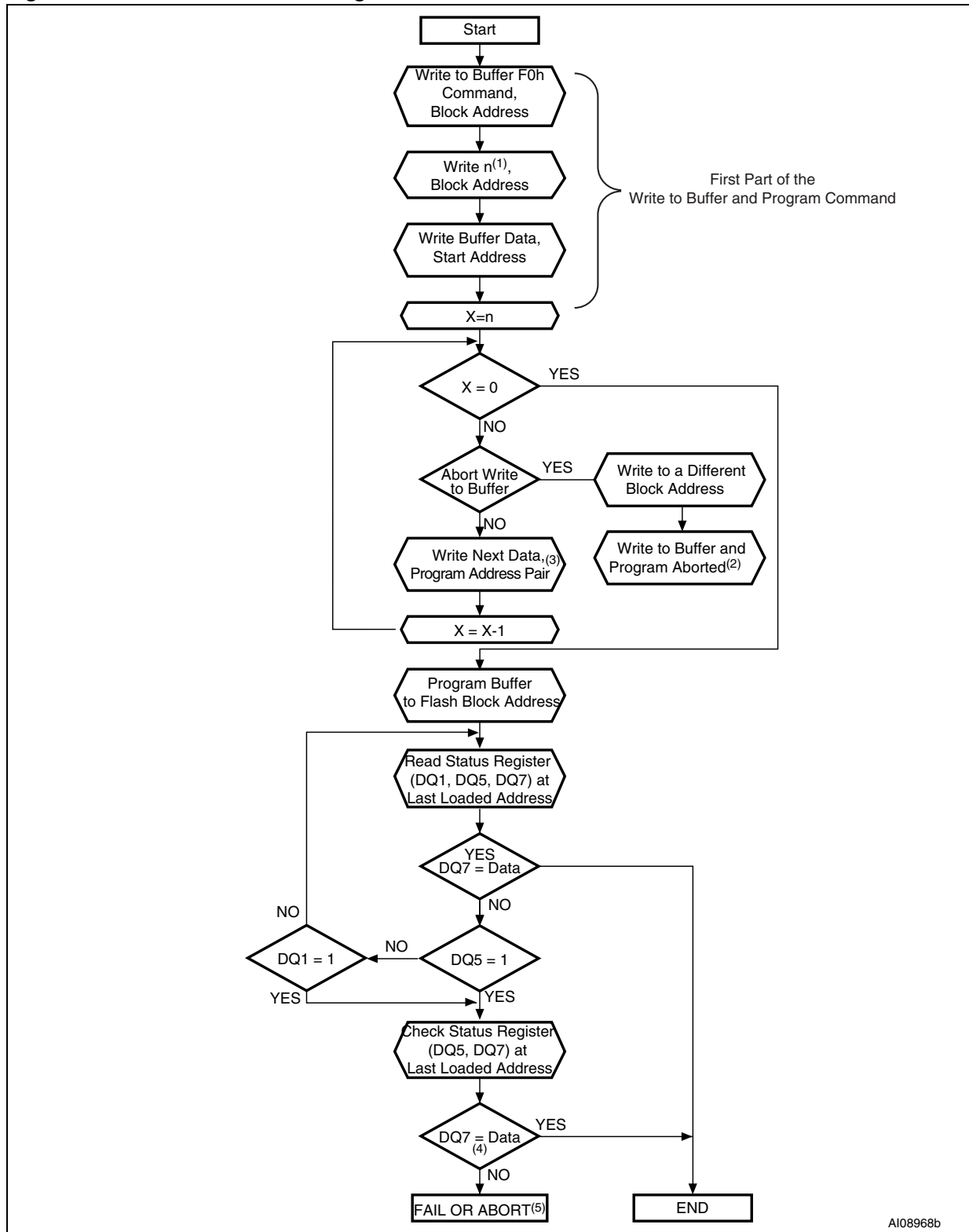

AI08968b

1. n+1 is the number of addresses to be programmed.
2. A Write to Buffer and Program Abort and Reset must be issued to return the device in Read mode.

3. When the block address is specified, any address in the selected block address space is acceptable. However when loading Write Buffer address with data, all addresses must fall within the selected Write Buffer page.
4. DQ7 must be checked since DQ5 and DQ7 may change simultaneously.
5. If this flowchart location is reached because DQ5='1', then the Write to Buffer and Program command failed. If this flowchart location is reached because DQ1='1', then the Write to Buffer and Program command aborted. In both cases, the appropriate reset command must be issued to return the device in Read mode: a Reset command if the operation failed, a Write to Buffer and Program Abort and Reset command if the operation aborted.
6. See *Table 11* and *Table 12*, for details on Write to Buffer and Program command sequence.

Revision history

Table 43. Document revision history

Date	Revision	Changes
02-Aug-2005	1.0	First Issue derived from the M29DW128F/FS datasheet revision 0.5.
13-Oct-2005	2.0	<i>Table 18: Program, Erase Times and Program, Erase Endurance Cycles</i> updated.
02-Dec-2005	3.0	Datasheet status updated to "FULL DATASHEET". Program Suspend Latency time updated in <i>Table 18: Program, Erase Times and Program, Erase Endurance Cycles</i> .
13-Mar-2006	4.0	<i>Table 19: Status Register bits</i> : DQ7 changed into $\overline{DQ7}$ for Program, Program Error and Program during Erase Suspend operations. <i>Section 6.2.1: Write to Buffer and Program command</i> , and <i>Section 6.2.2: Write to Buffer and Program Confirm command</i> updated to cover 8-bit mode. <i>Note 2</i> , <i>Note 3</i> , and <i>Note 4</i> updated in <i>Table 13: Fast Program Commands, 8-bit mode</i> .
13-Jun-2006	5	Blank Verify command added in <i>Section 6: Command interface</i> . Input/output supply voltage, V_{CCQ} , removed.
20-Jun-2006	6	Address Inputs A7-A0 modified for NVMPbits in <i>Table 17: Protection Command Addresses</i> .
26-Oct-2006	7	Updated <i>Table 19: Status Register bits</i> ; updated blank verify command description and removed verify command in <i>Section 6: Command interface</i> .
10-Dec-2007	8	Applied Numonyx branding.

Please Read Carefully:

INFORMATION IN THIS DOCUMENT IS PROVIDED IN CONNECTION WITH NUMONYX™ PRODUCTS. NO LICENSE, EXPRESS OR IMPLIED, BY ESTOPPEL OR OTHERWISE, TO ANY INTELLECTUAL PROPERTY RIGHTS IS GRANTED BY THIS DOCUMENT. EXCEPT AS PROVIDED IN NUMONYX'S TERMS AND CONDITIONS OF SALE FOR SUCH PRODUCTS, NUMONYX ASSUMES NO LIABILITY WHATSOEVER, AND NUMONYX DISCLAIMS ANY EXPRESS OR IMPLIED WARRANTY, RELATING TO SALE AND/OR USE OF NUMONYX PRODUCTS INCLUDING LIABILITY OR WARRANTIES RELATING TO FITNESS FOR A PARTICULAR PURPOSE, MERCHANTABILITY, OR INFRINGEMENT OF ANY PATENT, COPYRIGHT OR OTHER INTELLECTUAL PROPERTY RIGHT.

Numonyx products are not intended for use in medical, life saving, life sustaining, critical control or safety systems, or in nuclear facility applications.

Numonyx may make changes to specifications and product descriptions at any time, without notice.

Numonyx, B.V. may have patents or pending patent applications, trademarks, copyrights, or other intellectual property rights that relate to the presented subject matter. The furnishing of documents and other materials and information does not provide any license, express or implied, by estoppel or otherwise, to any such patents, trademarks, copyrights, or other intellectual property rights.

Designers must not rely on the absence or characteristics of any features or instructions marked "reserved" or "undefined." Numonyx reserves these for future definition and shall have no responsibility whatsoever for conflicts or incompatibilities arising from future changes to them.

Contact your local Numonyx sales office or your distributor to obtain the latest specifications and before placing your product order.

Copies of documents which have an order number and are referenced in this document, or other Numonyx literature may be obtained by visiting Numonyx's website at <http://www.numonyx.com>.

Numonyx StrataFlash is a trademark or registered trademark of Numonyx or its subsidiaries in the United States and other countries.

*Other names and brands may be claimed as the property of others.

Copyright © 11/5/7, Numonyx, B.V., All Rights Reserved.