



深圳市拓普微科技开发有限公司

SHENZHEN TOPWAY TECHNOLOGY CO., LTD.

LM3086BFW

LCD Module User Manual

Prepared by: Wangxikuan Date: 2017-06-06	Checked by: Date:	Approved by: Date:
--	----------------------------------	-----------------------------------

Rev.	Descriptions	Release Date
0.1	Preliminary release	2017-06-06

Table of Content

1. Basic Specifications	3
1.1 Display Specifications	3
1.2 Mechanical Specifications	3
1.3 Block Diagram	3
1.4 Terminal Functions	3
2. Absolute Maximum Ratings	4
3. Electrical Characteristics	4
3.1 DC Characteristics	4
3.2 LED Backlight Circuit Characteristics	4
3.3 AC Characteristics	5
4. Function specifications	6
4.1 Adjusting the Display Contrast	6
4.2 Basic Setting	6
4.3 Resetting the LCD module	6
4.4 Display Memory Map	6
4.5 Display Commands	7
5. Design and Handling Precaution	8

1. Basic Specifications

1.1 Display Specifications

- 1) LCD Display Mode : STN-Blue, Negative, Transmissive
- 2) Display Color : Display Data = "1" : Light Gray (*1)
: Display Data = "0" : Dark Blue (*2)
- 3) Viewing Angle : 12H
- 4) Driving Method : 1/33 duty, 1/7 bias
- 5) Backlight : White LED backlight

Note:

*1. Color tone may slightly change by Temperature and Driving Condition.

*2. The Color is defined as the inactive / background color.

*3. Fine Contrast adjustment function is necessary in the application design for optimal display result.

1.2 Mechanical Specifications

- 1) Outline Dimension : 150.0 x 23.0 x 11.8MAX (mm)
(See attached Outline Drawing for details)

1.3 Block Diagram

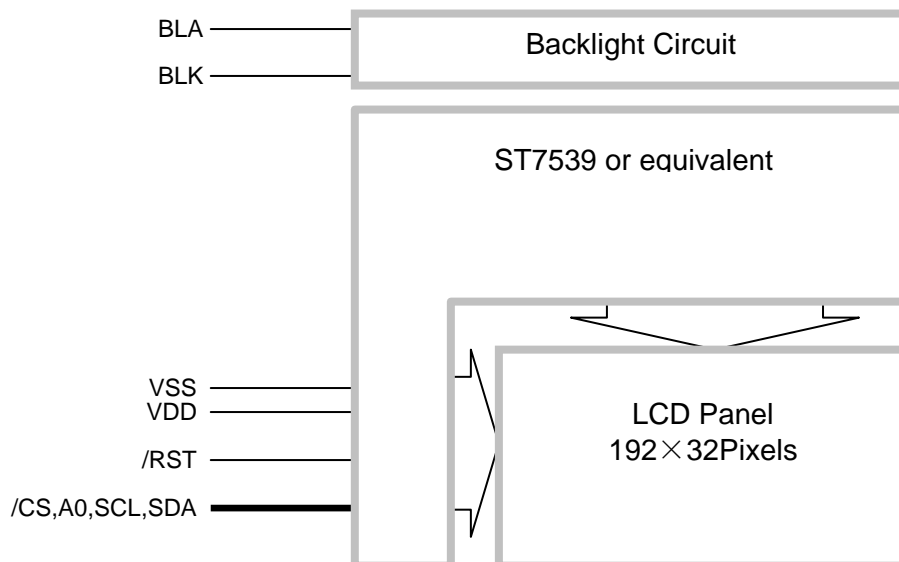

1.4 Terminal Functions

Pin No.	PIN Name	I/O	Descriptions
			Serial mode
1	/CS	Input	Chip select input pins /CS = L ,Chip is active /CS = H ,Chip is non-active
2	/RST	Input	Reset signal /RST = L, Initialization is executed /RST = H, Normal running
3	A0	Input	A0 = H, Transferring the Display Data A0 = L, Transferring the Control Data
4	SCL	Input	Serial Clock Input
5	SDA	Input	Serial Data Input
6	VDD	Power	Positive power supply
7	VSS	Power	Negative power supply,0V
8	NC	--	No Connect.
9	BLA	Power	Positive power for LED backlight
10	BLK	Power	Negative power for LED backlight,0V

2. Absolute Maximum Ratings

Items	Symbol	Min.	Max.	Unit	Condition
Supply Voltage	V_{DD}	-0.3	+3.8	V	$V_{SS} = 0V$
Input Voltage	V_{IN}	-0.3	$V_{DD}+0.2$	V	$V_{SS} = 0V$
Operating Temperature	T_{OP}	-20	+70	°C	No Condensation
Storage Temperature	T_{ST}	-30	+80	°C	No Condensation

Cautions:

Any Stresses exceeding the Absolute Maximum Ratings may cause substantial damage to the device. Functional operation of this device at other conditions beyond those listed in the specification is not implied and prolonged exposure to extreme conditions may affect device reliability.

3. Electrical Characteristics

3.1 DC Characteristics

$V_{SS}=0V, V_{DD}=3.3V, T_{OP}=25^{\circ}C$

Items	Symbol	MIN.	TYP.	MAX.	Unit	Condition / Application Pin
Operating Voltage	V_{DD}	3.0	3.3	3.6	V	VDD
Input High Voltage	V_{IH}	$0.8 \times V_{DD}$	-	V_{DD}	V	/CS, /RES, A0, SCL, SDA
Input Low Voltage	V_{IL}	V_{SS}	-	$0.2 \times V_{DD}$	V	
Operating Current	I_{DD}	-	0.3	1	mA	VDD

3.2 LED Backlight Circuit Characteristics

$V_{SS}=0V, BLA=3.3V, T_{OP} = 25^{\circ}C$

Items	Symbol	MIN.	TYP.	MAX.	Unit	Applicable Pin
Forward Voltage	V_{BLA}	-	3.3	-	V	BLA
Forward Current	I_{BLA}	-	25	40	mA	BLA

Cautions:

Exceeding the recommended driving current could cause substantial damage to the backlight and shorten its lifetime.

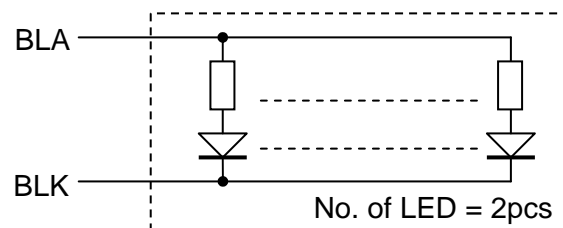

3.3 AC Characteristics

3.3.1 Serial Mode Interface

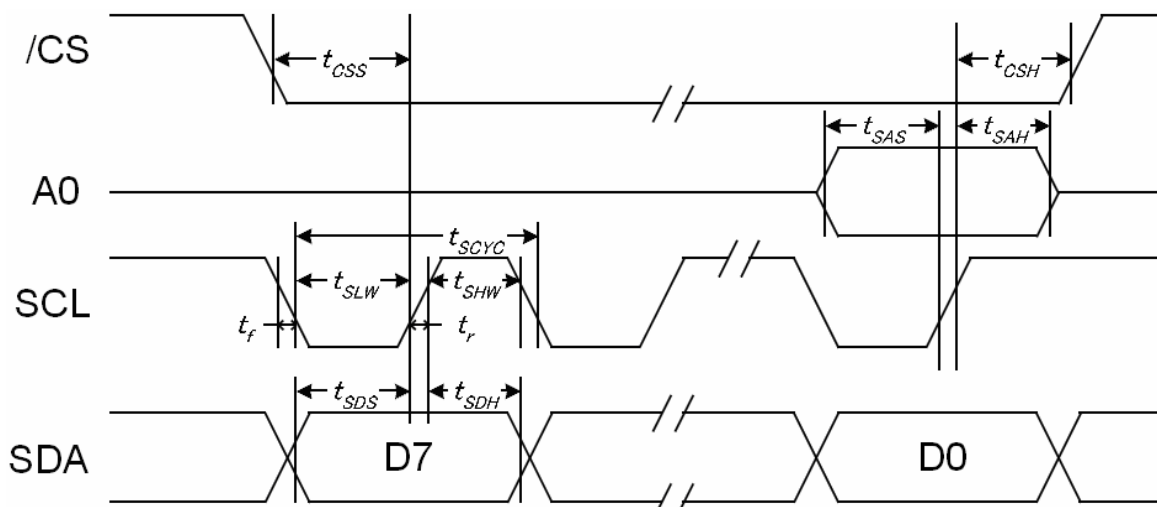

$V_{SS}=0V, V_{DD}=3.3V, T_{OP}=25^{\circ}C$

Item	Symbol	MIN.	TYP.	MAX.	Unit
Serial Clock Period	tscyc	78	-	-	ns
Address setup time (A0)	tsas	13	-	-	ns
Address hold time (A0)	tsah	13	-	-	ns
SCL "H" pulse width	tshw	20	-	-	ns
SCL "L" pulse width	tslw	20	-	-	ns
Data setup time	tsds	13	-	-	ns
Data hold time	tsdh	13	-	-	ns

Note:

*1. Input signal rise/fall time should be less than 15ns .

*2. CL=100pF

*3.All timing is using 20% and 80% of VDD as the reference.

3.3.2 Reset Timing

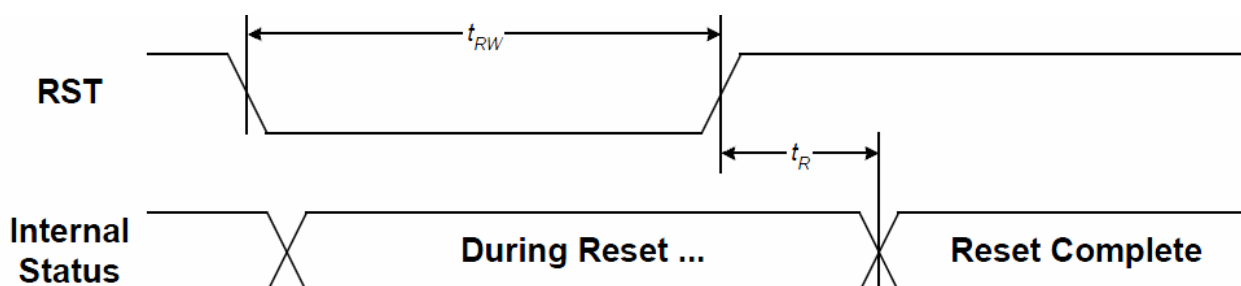

$V_{SS}=0V, V_{DD}=3.3V, T_{OP}=25^{\circ}C$

Item	Symbol	MIN.	TYP.	MAX.	Unit
Reset time	tr	-	-	1.3	ms
Reset LOW pulse width	trw	1.3	-	-	ms

Note:

*1.All timing is using 20% and 80% of VDD as the reference.

4. Function specifications

4.1 Adjusting the Display Contrast

- This LCD module equipped with latest digital contrast adjustment function.
- Its display contrast could be adjusted by MCU command. (please see the command tables for details)
- It is recommended to provide a contrast adjustment interface for end-user, where the best display result could meet the individual preference in mass production.

4.2 Basic Setting

To drive the LCD module correctly and provide normally display, please use the following setting

- Set Frame Rate 76 fps
- Set Bias 1/7
- Set Duty 1/33
- MX = 1, MY =0
- PS=1(Disable partial mode)
- AC[0:2]=1 (Set RAM Address Control)
- AP=0, INV=0 (Normal display)
- Display ON

Note:

*1. These setting/commands should issue the LCD module while start up.

*2. See the Display Commands section for details.

4.3 Resetting the LCD module

The LCD module should be initialized by using /RES terminal.

While turning on the VDD and VSS power supply, maintain /RES terminal at LOW level. After the power supply stabilized, release the reset terminal (/RES=HIGH)

4.4 Display Memory Map

Page address	data	LCD Display (front view)	
0	D0 : D7	192x32 pixels	
1	D0 : D7		
2	D0 : D7		
3	D0 : D7		
Column Address		00h	→ BFh

Note:

*1.MY=0

*2.MX=1

*3.Initial Display Line=0

4.5 Display Commands

COMMAND TABLE												
INSTRUCTION	A0	R/W	COMMAND BYTE								DESCRIPTION	
			D7	D6	D5	D4	D3	D2	D1	D0		
Write Data	1	0	D7	D6	D5	D4	D3	D2	D1	D0	Write data to DDRAM	
Read Data	1	1	D7	D6	D5	D4	D3	D2	D1	D0	Read data from DDRAM Only for parallel interface and I ² C	
Read Status Byte (parallel interface)	0	1	ID0	MX	MY	WA	DE	0	0	0	Read status byte Only for parallel interface	
			0	POR	0	0	0	ID3	ID2	ID1		
Read Status Byte (4-SPI)	0	1	1	1	1	1	1	1	1	0	Read status byte Only for 4 line SPI	
			ID0	MX	MY	WA	DE	0	0	0		ID3
Set Column Address LSB	0	0	0	0	0	0	CA3	CA2	CA1	CA0	Set column address of RAM	
Set Column Address MSB	0	0	0	0	0	1	CA7	CA6	CA5	CA4		
Set Scroll Line	0	0	0	1	SL5	SL4	SL3	SL2	SL1	SL0	Specify line address for the 1 st display line of DDRAM (vertical scrolling)	
Set Page Address	0	0	1	0	1	1	PA3	PA2	PA1	PA0	Set page address of RAM	
Set Contrast	0	0	1	0	0	0	0	0	0	1	2-byte instruction. Set Vop voltage	
			EV7	EV6	EV5	EV4	EV3	EV2	EV1	EV0		
Set Partial Screen Mode	0	0	1	0	0	0	0	1	0	PS	PS=1: Enable partial mode	
Set RAM Address Control	0	0	1	0	0	0	1	AC2	AC1	AC0	Set column and page address behavior	
Set Frame Rate	0	0	1	0	1	0	0	0	FR1	FR0	Set frame frequency	
Set All Pixel ON	0	0	1	0	1	0	0	1	0	AP	Set all display segments on	
Set Inverse Display	0	0	1	0	1	0	0	1	1	INV	Set inverse display	
Set Display Enable	0	0	1	0	1	0	1	1	1	PD	PD=0: Chip is in power down mode	
Scan Direction	0	0	1	1	0	0	0	MY	MX	0	Set COM and SEG scan direction	
Software Reset	0	0	1	1	1	0	0	0	0	1	0	Set software reset
NOP	0	0	1	1	1	0	0	0	0	1	1	No operation
Set Bias	0	0	1	1	1	0	1	0	BR1	BR0	Set internal bias circuit	
Set COM End	0	0	1	1	1	1	0	0	0	1	2-byte instruction. Set display duty	
			--	--	CEN5	CEN4	CEN3	CEN2	CEN1	CEN0		
Partial Start Address	0	0	1	1	1	1	0	0	1	0	Set partial start for partial display screen	
			--	--	DST5	DST4	DST3	DST2	DST1	DST0		
Partial End Address	0	0	1	1	1	1	0	0	1	1	Set partial end for partial display screen	
			--	--	DEN5	DE4	DEN3	DEN2	DEN1	DEN0		
Test Control	0	0	1	1	1	1	1	1	1	1	Set test command table	
			--	--	--	--	--	--	H1	H0		

- Note:
- *1. Do not use any other command not listed, or the system malfunction may result.
 - *2. For the details of the Display Commands, please refer to ST7539 data sheet.
 - *3. "--" = Disabled bit. It can be either logic 0 or 1.

5. Design and Handling Precaution

1. The LCD panel is made by glass. Any mechanical shock (eg. dropping from high place) will damage the LCD module.
2. Do not add excessive force on the surface of the display, which may cause the Display color change abnormally.
3. The polarizer on the LCD is easily get scratched. If possible, do not remove the LCD protective film until the last step of installation.
4. Never attempt to disassemble or rework the LCD module.
5. Only Clean the LCD with Isopropyl Alcohol or Ethyl Alcohol. Other solvents (eg. water) may damage the LCD.
6. When mounting the LCD module, make sure that it is free from twisting, warping and distortion.
7. Ensure to provide enough space (with cushion) between case and LCD panel to prevent external force adding on it, or it may cause damage to the LCD or degrade the display result.
8. Only hold the LCD module by its side. Never hold LCD module by add force on the heat seal or TAB.
9. Never add force to component of the LCD module. It may cause invisible damage or degrade of the reliability.
10. LCD module could be easily damaged by static electricity. Be careful to maintain an optimum anti-static work environment to protect the LCD module.
11. When peeling off the protective film from LCD, static charge may cause abnormal display pattern. It is normal and will resume to normal in a short while.
12. Take care and prevent get hurt by the LCD panel sharp edge.
13. Never operate the LCD module exceed the absolute maximum ratings.
14. Keep the signal line as short as possible to prevent noisy signal applying to LCD module.
15. Never apply signal to the LCD module without power supply.
16. IC chip (eg. TAB or COG) is sensitive to the light. Strong lighting environment could possibly cause malfunction. Light sealing structure casing is recommend.
17. LCD module reliability may be reduced by temperature shock.
18. When storing the LCD module, avoid exposure to the direct sunlight, high humidity, high temperature or low temperature. They may damage or degrade the LCD module