

SPECIFICATIONS FOR APPROVAL



Customer Part No.: _____ HELE. Part No: **X3S026000B71HZ-NCHPR**
 Application For: _____ Products: **CRYSTAL**
 Accepted Model: _____ Type & Freq.: **HSX321S / 26.000MHZ**
 Sample Order No: **EOS-790404-1** Date: **2007/10/02**

Approved By :

加高電子股份有限公司

加高電子股份有限公司

HARMONY ELECTRONICS CORP.

HARMONY ELECTRONICS (THAILAND) CO., LTD.

HARMONY ELECTRONICS (SHENZHEN) CORP., LTD.

TAIPEI OFFICE:

公司:(114)
 台北市內湖區堤頂大道 2 段 409 號 2 樓
 2F., NO.409, SEC.2, TIDING BLVD.,
 NEIHU DISTRICT, TAIPEI CITY 114,
 TAIWAN (R.O.C.)
 TEL:886-2-26588883
 FAX:886-2-26588683

TAIWAN FACTORY:

工廠:(831)
 高雄縣大寮鄉大發工業區華東路 39 號
 NO. 39, HWA DONG RD., TA FA IND.
 DIST., TA LIAO KAOHSIUNG HSIEN 831,
 TAIWAN, R.O.C.
 TEL: (07)787-1555-6
 FAX: (07)787-1557

THAILAND FACTORY:

66MOO 5, KAONGU-BEOKPRAI RD.,
 T.BEOKPRAI, A. BANPONG,
 RAJCHABUREE PROVINCE 70110,
 THAILAND
 TEL: (032)221994-6, 200740-1
 FAX: (032)200742

SHENZHEN FACTORY:

深圳市福永鎮塘尾村塘橋路聚源工業區
 QIAO TANG RD., TANGWEI VILLAGE
 FU YONG TOWN SHENZHEN CITY
 CHINA
 TEL: 0755-7309272 / 7309262
 FAX: 0755-7309755

Title HSX321S				Remark		
QUARTZ CRYSTAL SPECIFICATION				TAIWAN FACTORY		
Date	Confirm	Check	Prepare	Spec. No.	Rev.	Page
2007/10/02	F. S. TSAI	C. L. WANG	U. F. CHEN	X3S026000B71HZ-NCHPR	0	1

HARMONY ELECTRONICS CORP.

HSX321S SPECIFICATION

INDEX

ITEM	PAGE
1. QUARTZ CRYSTAL UNIT SPECIFICATION	3
2. MARKING & DIMENSIONS	4
3. INSIDE STRUCTURE	5
4. EMBOSS CARRIER TAPE&REEL	6
a. DIMENSIONS OF CARRIER TAPE	6
b. DIMENSIONS OF REEL	6-7
c. STORAGE CONDITION	7
d. STANDARD PACKING QUANTITY	7
e. MATERIAL OF TAPE	7
f. LABEL CONTENTS	7
g. TAPING DIMENSION	8
h. JOINT OF TAPE	8
i. RELEASE STRENGHT OF COVER TAPE	8
5. MECHANICAL PERFORMANOE	9
6. ENVIRONMENTAL PERFORMANOE	9-10
7. SUPPLRMENT	10-11
8. FLOW CHARD	12
9. Environmental Workload Chemical Substance Components List .	13
10. TEST DATA	

Title HSX321S QUARTZ CRYSTAL SPECIFICATION				Remark TAIWAN FACTORY		
Date	Confirm	Check	Prepare	Spec. No.	Rev.	Page
2007/10/02	F. S. TSAI	C. L. WANG	U. F. CHEN	X3S026000B71HZ-NCHPR	0	2

1. QUARTZ CRYSTAL UNIT SPECIFICATION

1. Frequency:	26.000000MHz
2. Holder type :	HSX321S
3. Frequency tolerance:	+/-10 ppm at 25deg.C +/-3deg.C
4. Equivalent resistance:	34 ohms Max. / SERIES
5. Storage temperature range:	-40 deg.C To +85 deg.C
6. Operable temperature range:	-20 deg.C To +75 deg.C
7. Temperature drift:	+/-10 ppm -20 deg.C To +75deg.C
8. Loading capacitance (CL) :	7.9 pF +/- 0.2 pF
9. Drive level:	100 μ W +/-10 μ W
10. Shunt Capacitance:	1.5 pF +/- 15%
11. Insulation resistance :	More than 500M ohms at DC 100V
12. Mode of oscillation:	Fundamental
13. Circuit:	Measured in HP/E5100A,S&A 250B
14. Shocking :	Dropping from 50 cm height 3 times on firm wood
Variation :	Frequency less than +/-5 ppm Resistance less than +/- 15 % or 2ohms max.
15. Aging:	Less than +/-1ppm/Year
16. Holder	HSX321S Seam type
17. Dimensions and marking	Refer to page.4
18. Emboss carrier tape & reel	Refer to page.6 and page.7
19. Note:	C1 : 4.92 fF +/-15% TS : >27.5 ppm/pF

Title HSX321S QUARTZ CRYSTAL SPECIFICATION				Remark TAIWAN FACTORY		
Date	Confirm	Check	Prepare	Spec. No.	Rev.	Page
2007/10/02	F. S. TSAI	C. L. WANG	U. F. CHEN	X3S026000B71HZ-NCHPR	0	3

2. HSX321S MARKING & DIMENSIONS

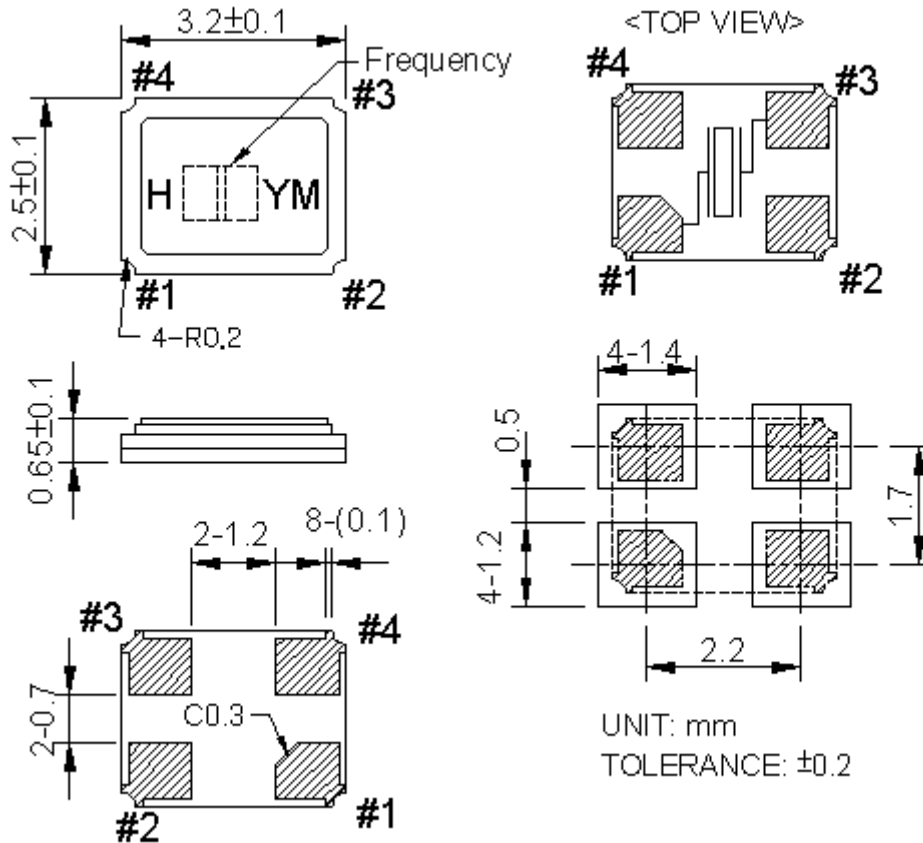

- *Marking should be printed as following:
Logo, Nominal Frequency, Manufactured year & month
- *Nominal frequency = integer only
(ex. 14.31818 MHz \rightarrow 14)
- *Manufacturing Lot No.
(Y: year) ex. 2000 shall be marked as ' 0 ' (The last digit of the year)
(M: month) ex. June shall be marked as ' F ' (As shown on the Table-1).

Marking : Laser marking.

(Table-1)

Jan.	Feb.	Mar.	Apr.	May.	Jun.	Jul.	Aug.	Sep.	Oct.	Nov.	Dec.
A	B	C	D	E	F	G	H	J	K	L	M

Title HSX321S QUARTZ CRYSTAL SPECIFICATION				Remark TAIWAN FACTORY			
Date	Confirm	Check	Prepare	Spec. No.	Rev.	Page	
2007/10/02	F. S. TSAI	C. L. WANG	U. F. CHEN	X3S026000B71HZ-NCHPR	0	4	

HARMONY ELECTRONICS CORP.

3. INSIDE STRUCTURE

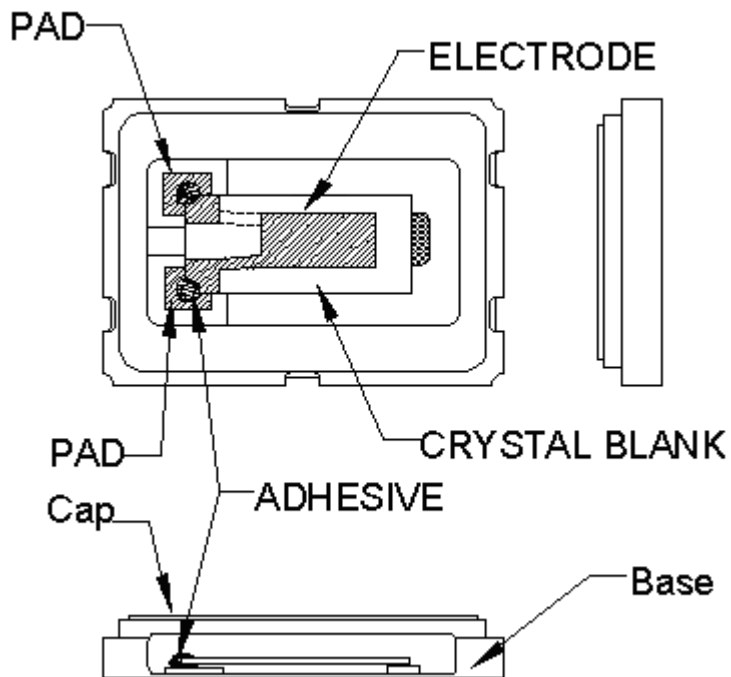

※Reference drawing

(1) Base: Alumina Ceramic (Al_2O_3) Metallized Pad: W Ni Plating Au Plating
(2) Cap: Fe-Ni
(3) Crystal Enclosure Seal: Seal Seam
(4) Crystal Blank Rectangular At-Cut Quartz Crystal Blank
(5) Adhesive Silver Conductive Polyimide Resin
(6) Electrode Au
(7) PAD Alumina Ceramic (W. Ni. Au)

The use prohibition chemistry substance of Table 1 of DHE-0204-1 (QA-QM-08) is not included in this item.

Title HSX321S QUARTZ CRYSTAL SPECIFICATION				Remark TAIWAN FACTORY		
Date	Confirm	Check	Prepare	Spec. No.	Rev.	Page
2007/10/02	F. S. TSAI	C. L. WANG	U. F. CHEN	X3S026000B71HZ-NCHPR	0	5

4. HSX321S EMOSS CARRIER TAPE & REEL

a.) Dimensions of Carrier Tape

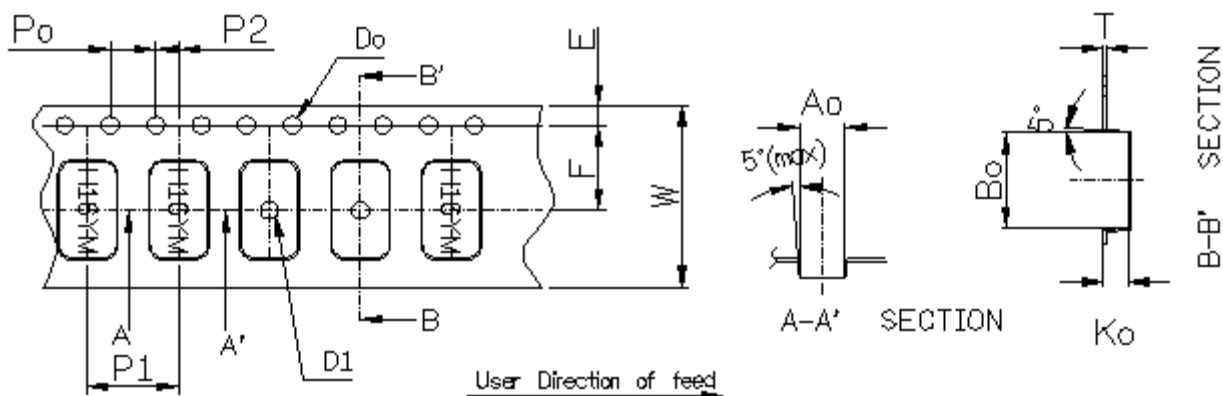

Symbol	A_0	B_0	K_0	P_0	P_1	P_2
Spec	2.70 ± 0.1	3.4 ± 0.1	1.40 ± 0.1	4.0 ± 0.1	4.0 ± 0.1	2.0 ± 0.05
Symbol	E	F	D_0	D_1	W	T
Spec	1.75 ± 0.1	3.5 ± 0.05	$\phi 1.55 \pm 0.05$	$\phi 1.0$ (min)	8.0 ± 0.2	0.25 ± 0.05

b.) Dimensions of Reel

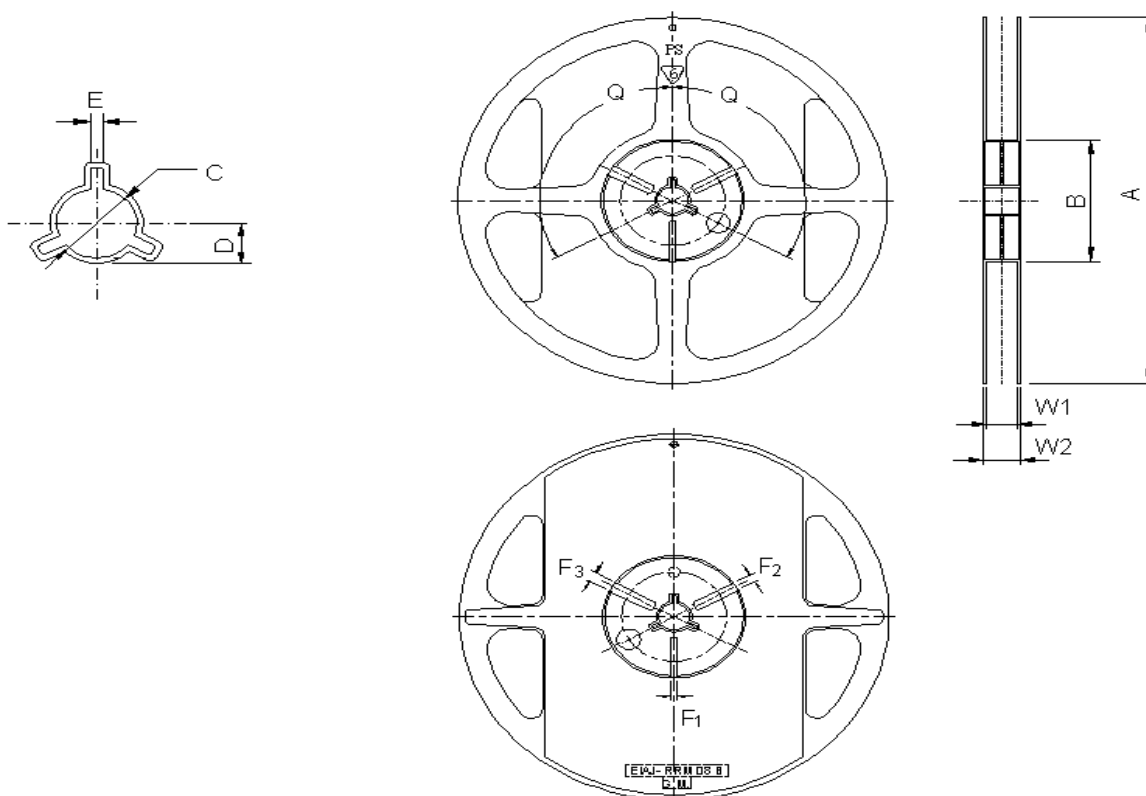

(Table-2)

(UNIT: mm)

Tittle HSX321S QUARTZ CRYSTAL SPECIFICATION				Remark TAIWAN FACTORY		
Date	Confirm	Check	Prepare	Spec. No.	Rev.	Page
2007/10/02	F. S. TSAI	C. L. WANG	U. F. CHEN	X3S026000B71HZ-NCHPR	0	6

ITEM		MARK	DIMENSIONS · ANGLE
FLANCE	Diameter		A ϕ 178+1/-1
	Inner Width		W1 8.0+/-1.5
	Outer Width		W2 11.5+/-0.2
HUB	Out Line diameter		B ϕ 60+1.0/-0.0
	Center Core slit	Width	F1 3.0+0.5/-0
			F2 4.0+0.5/-0
			F3 5.0+0.5/-0
	Position		q 120deg
	Spindle diameter		C ϕ 13+/-0.5
Key Ditch	Width	E 2.5+/-0.5/-0	

c.) Storage condition

Temperature: +40deg.C Max.

Relative Humidity: 80% Max.

d.) Standard packing quantity

3,000PCS / REEL

e.) Material of the tape

Tape	Material
Carrier tape	A – PET
Top tape	Polyester

f.) Label contents

- .The type of product
- .Our specification No.
- .Your Part No.
- .Lot No.
- .Nominal Frequency
- .Quantity
- .Our Company Name

Sticks label for every reel.

TYPE	
SPEC NO.	
Parts NO.	
Lot No.	
FREQ.	
Q'TY	(RoHS Compliance)
H.E.E. HARMONY ELECTRONICS CORP.	

Title HSX321S

QUARTZ CRYSTAL SPECIFICATION

Remark

TAIWAN FACTORY

Date	Confirm	Check	Prepare	Spec. No.	Rev.	Page
2007/10/02	F. S. TSAI	C. L. WANG	U. F. CHEN	X3S026000B71HZ-NCHPR	0	7

HARMONY ELECTRONICS CORP.

g.) Taping dimension

Leader	Cover-tape	The length of cover-tape in the leader is more than 400 mm including empty embossed area.
	Carrier-tape	After all products were packaged, must remain more than twenty pieces or 400 mm empty area, which should be sealed by cover-tape.
Terminal	Cover-tape	The tip of cover-tape shall be fixed temporary by paper tape and roll around the core of reel one round.
	Carrier-tape	The empty embossed area which are sealed by top cover-tape must remain more the 40 mm.

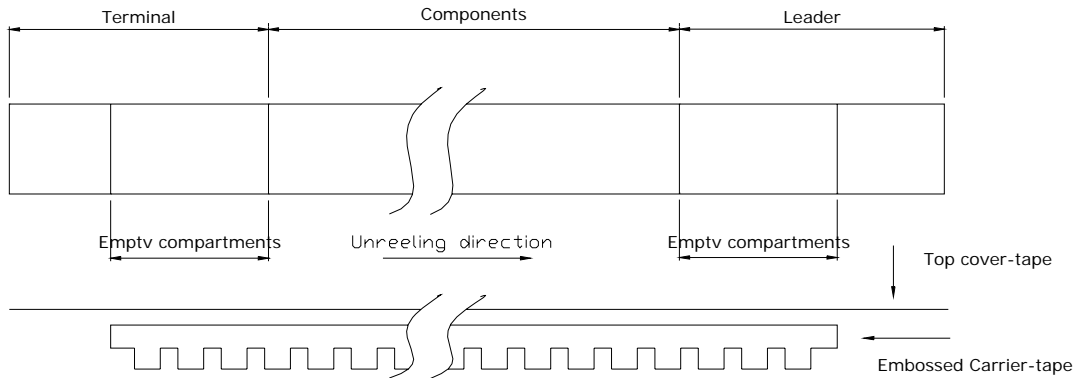

h.) Joint of tape

The carrier-tape and top cover-tape should not be jointed.

i.) Release strength of cover tape

It has to between 0.1N to 0.7N under following condition.

Pulling direction 165° to 180°

Speed 300mm/min.

Otherwise unless specified.

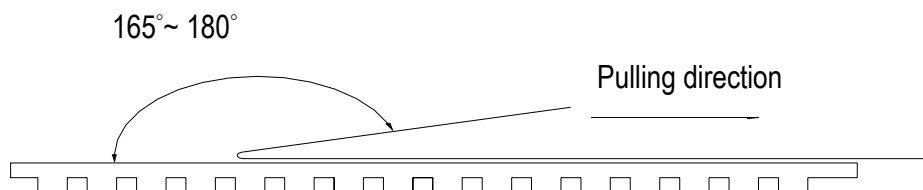

Other standards shall be based on JIS C 0806-1990.

Title HSX321S QUARTZ CRYSTAL SPECIFICATION				Remark TAIWAN FACTORY		
Date	Confirm	Check	Prepare	Spec. No.	Rev.	Page
2007/10/02	F. S. TSAI	C. L. WANG	U. F. CHEN	X3S026000B71HZ-NCHPR	0	8

5. Mechanical Performance

5.1.Natural Drop

Drop 3 times from the height of 50cm onto min. 30mm thickness hard wooden board
The component shall satisfy requirement of the electrical characteristics.

5.2.Vibration

Frequency 10-55Hz, Sine Wave full amplitude of 1.5mm to X,Y and Z 3 axes, Duration of 2 hours to each axis.
The component shall satisfy requirement of the electrical characteristics.

5.3.Sealing Tightness

Leak Rate 1.0×10^{-7} Pa·m³/sec. Max. measured by Helium leak detector.

5.4.Solderability

After applying ROSIN Flux, dipping in solder bath at 230°C +/-5°C for 5 sec.
Over 90% of terminal shall be covered by solder.

6. Environment Performance

6.1.Humidity

Temperature 60°C +/-2°C, RH 90~95%, Duration of 240 hours
Back to room temperature first, then in 1~2 hours, the component shall be checked.
The component shall satisfy requirement of the electrical characteristics.
No physical damage

6.2.Storage in Low Temperature

-30°C +/-2°C, Duration of 240 hours.
Back to the room temperature first, then in 1~2 hours, the component shall be checked.
The component shall satisfy requirement of the electrical characteristics.
No physical damage

6.3.Storage in High Temperature

+85°C +/-2°C, Duration of 240 hours.
Back to the room temperature first, then in 1~2 hours, the component shall be checked.
The component shall satisfy requirement of the electrical characteristics.
No physical damage

Tittle HSX321S				Remark		
QUARTZ CRYSTAL SPECIFICATION				TAIWAN FACTORY		
Date	Confirm	Check	Prepare	Spec. No.	Rev.	Page
2007/10/02	F. S. TSAI	C. L. WANG	U. F. CHEN	X3S026000B71HZ-NCHPR	0	9

6.4. Temperature cycles

-30°C +/- 2°C (30min) ↔ +85°C +/- 2°C (30min) 20 cycles

Back to the room temperature first, then in 1~2 hours, the component shall be checked.

The component shall satisfy requirement of the electrical characteristics.

No physical damage

6.5. VPS

FC-70 (the boiling point: +215°C) Vapor for 30 sec

Back to the room temperature first, then in 1~2 hours, the component shall be checked.

The component shall satisfy requirement of the electrical characteristics.

No physical damage

7. Supplement

7.1. Soldering

7.2. Please stay with our proposed reflow condition and do then soldering 2 times max.

Available for Lead Free Soldering

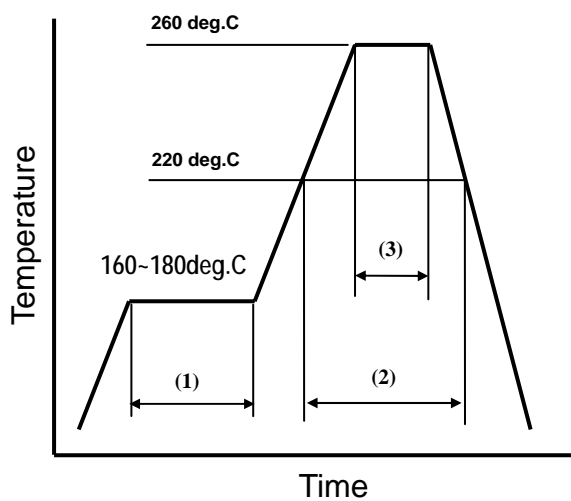

(1)	Preheat	160~180 deg.C	120sec.
(2)	Primary heat	220 deg.C	60sec.
(3)	Peak	260 deg.C	10sec. Max.

Title HSX321S

QUARTZ CRYSTAL SPECIFICATION

Remark

TAIWAN FACTORY

Date	Confirm	Check	Prepare	Spec. No.	Rev.	Page
2007/10/02	F. S. TSAI	C. L. WANG	U. F. CHEN	X3S026000B71HZ-NCHPR	0	10

HARMONY ELECTRONICS CORP.

7.3.Land pattern layout(Example)

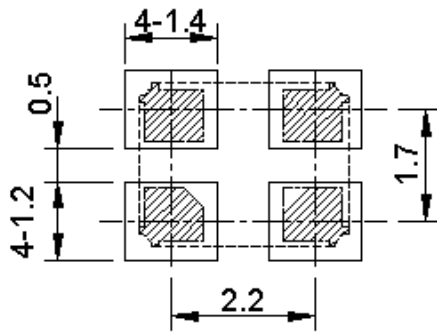

7.4.Solder iron (Example)

Bit temp.:350°C max.,Time:3sec max. ,Each terminal solder a 1 time max.

7.5.Mounting

This component is designed for automatic insertion.

However, you are requested to do the trial with your insertion machine in order to be sure of proper operation and no damage of component.

Please pay attention to board warp which may damage the component and cause Soldering Process.

7.6.Cleaning

Cleaning liquid which corrodes Nickel shall not be used

It may cause the problem on the surface, color, marking etc.

Ultra-sonic cleaning is possible, however, you are requested to check on your board.

Because we only checked as single unit.

7.7.Storage

Please keep away from high temperature and high humidity ,which may cause put solderbility. No direct Sunlight, No dew as well.

Tittle HSX321S QUARTZ CRYSTAL SPECIFICATION				Remark TAIWAN FACTORY		
Date	Confirm	Check	Prepare	Spec. No.	Rev.	Page
2007/10/02	F. S. TSAI	C. L. WANG	U. F. CHEN	X3S026000B71HZ-NCHPR	0	11

8. Flow Chard

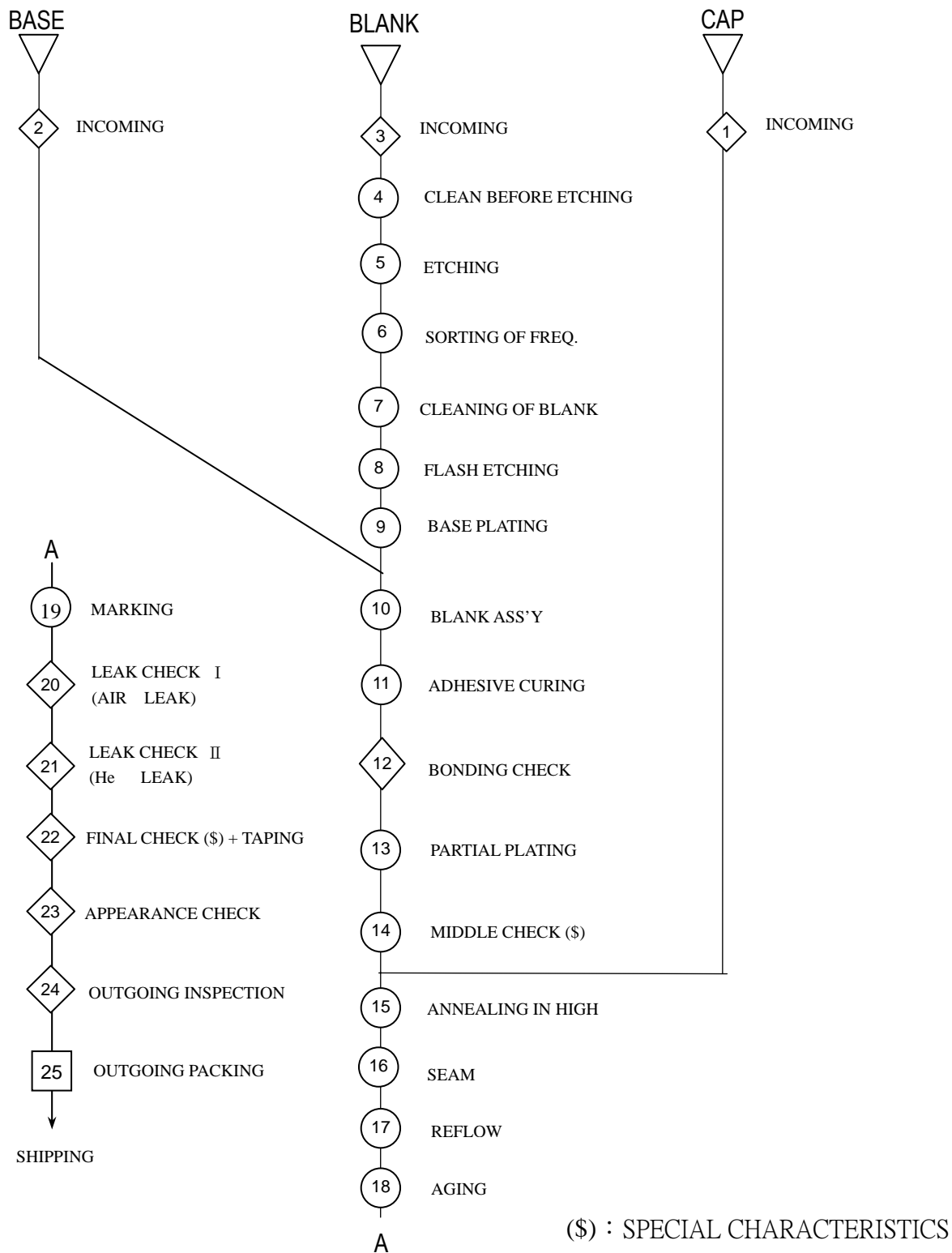

Tittle HSX321S				Remark		
QUARTZ CRYSTAL SPECIFICATION				TAIWAN FACTORY		
Date	Confirm	Check	Prepare	Spec. No.	Rev.	Page
2007/10/02	F. S. TSAI	C. L. WANG	U. F. CHEN	X3S026000B71HZ-NCHPR	0	12

9. Environmental Workload Chemical Substance Components List

Environmental Workload Chemical Substance Components List		
TYPE	H(D)SX321S	
PERCENTAGE		
Chemical Substance Components	19(mg)	ppm
Si	0.0437	2,300
Au	0.1463	7,700
Co & Co Compound	1.1286	59,400
Mo & Mo Compound	0.0380	2,000
Ag	0.3952	20,800
Cu	0.1102	5,800
Cr & Cr Compound	0.0380	2,000
Al	4.7234	248,600
Mn & Mn Compound	0.0228	1,200
W & W Compound	0.1843	9,700
Ni & Ni Compound	2.8424	149,600
Fe	3.8437	202,300

Title HSX321S QUARTZ CRYSTAL SPECIFICATION				Remark TAIWAN FACTORY		
Date	Confirm	Check	Prepare	Spec. No.	Rev.	Page
2007/10/02	F. S. TSAI	C. L. WANG	U. F. CHEN	X3S026000B71HZ-NCHPR	0	13

REV. No.	DATE	REASON	CONTENTS
0	2007/10/02	New	

Title HSX321S QUARTZ CRYSTAL SPECIFICATION				Remark TAIWAN FACTORY		
Date	Confirm	Check	Prepare	Spec. No.	Rev.	Page
2007/10/02	F. S. TSAI	C. L. WANG	U. F. CHEN	X3S026000B71HZ-NCHPR	0	14

HARMONY ELECTRONICS CORP.

EXCEL EXPORT PRINTOUT FORMAT

Run Date : 02-10-2007 11:44 am
 S&A 250B: 9.40 Report: 4.60
 Description: eos-790404-1

Reference Fr: 26,000,000.00 (Using Measured FL)
 Power: 10.00 uW Into 20.0 ohms
 PL: 0.00 ohms CL: 7.90 pF

Crystal	First Failure	FR Hz	FL Hz	FL ppm	RR Ohms	C0 pF	C1 fF	C0/C1	L mH	Q k	TS ppm/pF	RLD2 Ohms	DLD2 Ohms	FDLD ppm
High Limit					34	1.7	5.66							
Low Limit						1.3	4.18				27			
1	PASS	25992540.6	26000266.2	10.24	19.43	1.48	5.49	269.54	6.83	57.38	31.21	20.32	1.50	0.24
2	PASS	25992379.3	26000222.0	8.54	15.01	1.50	5.60	268.37	6.69	72.78	31.68	15.20	0.62	0.48
3	PASS	25992510.4	26000271.5	10.44	23.31	1.53	5.56	274.44	6.74	47.22	31.30	26.21	4.45	2.48
4	PASS	25992400.9	26000286.7	11.03	16.02	1.52	5.64	268.71	6.64	67.72	31.82	16.20	0.46	0.55
5	PASS	25992525.4	26000223.7	8.60	16.76	1.46	5.47	267.23	6.85	66.78	31.20	16.88	0.77	1.46
6	PASS	25992294.9	25999981.1	-0.73	19.19	1.50	5.49	273.48	6.83	58.17	31.04	19.22	0.53	0.58
7	PASS	25992433.8	25999993.5	-0.25	20.57	1.50	5.40	277.85	6.94	55.07	30.57	22.04	2.75	1.22
8	PASS	25992409.0	26000017.2	0.66	15.77	1.48	5.42	272.53	6.92	71.65	30.81	15.71	0.84	0.46
9	PASS	25992363.1	25999994.2	-0.22	22.20	1.46	5.43	269.30	6.90	50.79	30.98	22.11	0.41	0.64
10	PASS	25992376.8	26000004.8	0.18	17.92	1.48	5.44	273.00	6.89	62.85	30.87	17.95	0.45	0.37
11	PASS	25992472.1	25999789.4	-8.10	17.73	1.47	5.22	282.13	7.19	66.22	29.70	17.83	0.90	0.54
12	PASS	25992401.7	25999716.2	-10.92	18.25	1.46	5.19	280.30	7.22	64.59	29.67	18.40	0.61	0.96
13	PASS	25992393.4	25999791.8	-8.01	19.96	1.48	5.27	280.82	7.11	58.17	29.96	20.06	0.74	0.75
14	PASS	25992398.4	25999829.7	-6.55	20.71	1.48	5.29	279.78	7.08	55.84	30.08	21.20	0.82	2.35
15	PASS	25992325.3	25999757.5	-9.33	17.79	1.47	5.29	278.35	7.09	65.10	30.10	19.43	2.09	1.26

Test Report

DAISHINKU CORP.(KDS)
HARMONY ELECTRONICS CORPORATION
NO.39, HUADONG RD., DALIAO TOWNSHIP, KAOHSIUNG COUNTY 831,
TAIWAN (R.O.C.)

Report No. : KA/2007/81047
Date : 2007/08/23
Page : 1 of 4



The following sample(s) was/were submitted and identified by/on behalf of the client as :

Sample Description	:	CRYSTAL RESONATORS
Style/Item No.	:	HSX321S,DSX321S(Au)
Color	:	BROWN+GOLD
Sample Receiving Date	:	2007/08/16
Testing Period	:	2007/08/16 TO 2007/8/23

Test Result(s) : - Please see the next page(s) -

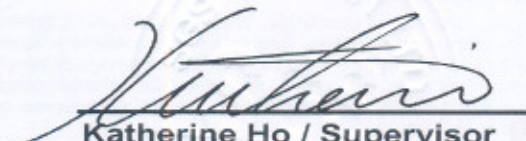
Katherine Ho / Supervisor
Signed for and on behalf of
SGS Taiwan Limited

This Test Report is issued by the Company subject to its General Conditions of Service printed overleaf or available on request and accessible at www.sgs.com. Attention is drawn to the limitations of liability, indemnification and jurisdictional issues defined therein. Unless otherwise stated the results shown in this test report refer only to the sample(s) tested. This test report cannot be reproduced, except in full, without prior written permission of the Company. Any unauthorized alteration, forgery or falsification of the content or appearance of this report is unlawful and offenders may be prosecuted to the fullest extent of the law. 此報告是遵照本公司訂定之通用服務條款所製作發放，請注意此條款列印於背面，亦可在www.sgs.com中查閱。將本公司之義務，免責，管轄權皆明確規範之。除非另有說明，此報告結果僅對檢驗之樣品負責。本報告未經本公司書面許可，不可部份複製。對本報告內容或外觀之任何未經授權之變更、偽造、篡改皆屬非法，違犯者將會被依法追究。

TW5337589

Test Report

DAISHINKU CORP.(KDS)
 HARMONY ELECTRONICS CORPORATION
 NO.39, HUADONG RD., DALIAO TOWNSHIP, KAOHSIUNG COUNTY 831, TAIWAN
 (R.O.C.)

Report No. : KA/2007/81047

Date : 2007/08/23

Page : 2 of 4



Test Result(s)

PART NAME NO.1 : CRYSTAL RESONATORS

Test Item (s)	Unit	Method	MDL	Result
				No. 1
Cadmium (Cd)	mg/kg	With reference to IEC 62321, ED.1 (111/54/CDV). Determination of Cadmium by ICP-AES.	2	n.d.
Hexavalent Chromium Cr(VI) by alkaline extraction	mg/kg	With reference to IEC 62321, Ed.1 111/54/CDV. Determination of Hexavalent Chromium for non-metallic samples by UV/vis Spectrometry.	2	n.d.
Mercury (Hg)	mg/kg	With reference to IEC 62321, ED.1 (111/54/CDV). Determination of Mercury by ICP-AES.	2	n.d.
Lead (Pb)	mg/kg	With reference to IEC 62321, ED.1 (111/54/CDV). Determination of Lead by ICP-AES.	2	n.d.
Sum of PBBs	mg/kg	With reference to IEC 62321, ED.1 (111/54/CDV). Determination of PBBs and PBDEs by GC/MS.	-	n.d.
Monobromobiphenyl			5	n.d.
Dibromobiphenyl			5	n.d.
Tribromobiphenyl			5	n.d.
Tetrabromobiphenyl			5	n.d.
Pentabromobiphenyl			5	n.d.
Hexabromobiphenyl			5	n.d.
Heptabromobiphenyl			5	n.d.
Octabromobiphenyl			5	n.d.
Nonabromobiphenyl			5	n.d.
Decabromobiphenyl	5	n.d.		

This Test Report is issued by the Company subject to its General Conditions of Service printed overleaf or available on request and accessible at www.sgs.com. Attention is drawn to the limitations of liability, indemnification and jurisdictional issues defined therein. Unless otherwise stated the results shown in this test report refer only to the sample(s) tested. This test report cannot be reproduced, except in full, without prior written permission of the Company. Any unauthorized alteration, forgery or falsification of the content or appearance of this report is unlawful and offenders may be prosecuted to the fullest extent of the law. 此報告是遵照本公司訂定之通用服務條款所製作發給。請注意此條款列印於背面，亦可在 www.sgs.com 中查閱。將本公司之義務，免責，管轄權皆明確規範之。除非另有說明，此報告結果僅對檢驗之樣品負責。本報告未經本公司書面許可，不可部份複製。對本報告內容或外觀之任何未經授權之變更、偽造、竄改皆屬非法，違犯者將會被依法追訴。

TW5337588

Test Report

DAISHINKU CORP.(KDS)
HARMONY ELECTRONICS CORPORATION

NO.39, HUADONG RD., DALIAO TOWNSHIP, KAOHSIUNG COUNTY 831, TAIWAN
(R.O.C.)

Report No. : KA/2007/81047

Date : 2007/08/23

Page : 3 of 4



Test Item (s)	Unit	Method	MDL	Result
				No. 1
Sum of PBDEs (Mono to Nona)(Note 4)	mg/kg	With reference to IEC 62321, ED.1 (111/54/CDV). Determination of PBBs and PBDEs by GC/MS.	-	n.d.
Monobromobiphenyl ether			5	n.d.
Dibromobiphenyl ether			5	n.d.
Tribromobiphenyl ether			5	n.d.
Tetrabromobiphenyl ether			5	n.d.
Pentabromobiphenyl ether			5	n.d.
Hexabromobiphenyl ether			5	n.d.
Heptabromobiphenyl ether			5	n.d.
Octabromobiphenyl ether			5	n.d.
Nonabromobiphenyl ether			5	n.d.
Decabromobiphenyl ether			5	n.d.
Sum of PBDEs (Mono to Deca)				
Halogen	---	---	---	---
Halogen-Fluorine (F) (CAS No:007782-41-4)	mg/kg	With reference to IEC 61189-2 TEST 2C12. Analysis was performed by IC method for Fluorine content.	50	n.d.
Halogen-Chlorine (Cl) (CAS No:007782-50-5)	mg/kg	With reference to IEC 61189-2 TEST 2C12. Analysis was performed by IC method for Chlorine content.	50	n.d.
Halogen-Bromine (Br) (CAS No:007726-95-6)	mg/kg	With reference to IEC 61189-2 TEST 2C12. Analysis was performed by IC method for Bromine content.	50	n.d.
Halogen-Iodine (I) (CAS No:007553-56-2)	mg/kg	With reference to IEC 61189-2 TEST 2C12. Analysis was performed by IC method for Iodine content.	50	n.d.

- Note :
1. mg/kg = ppm
 2. n.d. = Not Detected
 3. MDL = Method Detection Limit
 4. According to 2005/717/EC DecaBDE is exempt.
 5. " - " = Not Regulated
 6. " --- " = Not Conducted

This Test Report is issued by the Company subject to its General Conditions of Service printed overleaf or available on request and accessible at www.sgs.com. Attention is drawn to the limitations of liability, indemnification and jurisdictional issues defined therein. Unless otherwise stated the results shown in this test report refer only to the sample(s) tested. This test report cannot be reproduced, except in full, without prior written permission of the Company. Any unauthorized alteration, forgery or falsification of the content or appearance of this report is unlawful and offenders may be prosecuted to the fullest extent of the law. 此報告是遵照本公司訂定之通用服務條款所製作發放，請注意此條款列印於背面，亦可在www.sgs.com中查閱。將本公司之義務、免責、管轄權皆明確規範之。除非另有說明，此報告結果僅對檢驗之樣品負責。本報告未經本公司書面許可，不可部份複製。對本報告內容或外觀之任何未經授權之變更、偽造、竄改皆屬非法，違犯者將會被依法追訴。

TW5337587

Test Report

DAISHINKU CORP.(KDS)
HARMONY ELECTRONICS CORPORATION
NO.39, HUADONG RD., DALIAO TOWNSHIP, KAOHSIUNG COUNTY 831,
TAIWAN (R.O.C.)

Report No. : KA/2007/81047

Date : 2007/08/23

Page : 4 of 4



** End of Report **

This Test Report is issued by the Company subject to its General Conditions of Service printed overleaf or available on request and accessible at www.sgs.com. Attention is drawn to the limitations of liability, indemnification and jurisdictional issues defined therein. Unless otherwise stated the results shown in this test report refer only to the sample(s) tested. This test report cannot be reproduced, except in full, without prior written permission of the Company. Any unauthorized alteration, forgery or falsification of the content or appearance of this report is unlawful and offenders may be prosecuted to the fullest extent of the law. 此報告是遵照本公司訂定之通用服務條款所製作發放，請注意此條款列印於背面，亦可在www.sgs.com中查閱。將本公司之義務，免責，管轄權皆明確規範之。除非另有說明，此報告結果僅對檢驗之樣品負責。本報告未經本公司書面許可，不可部份複製。對本報告內容或外觀之任何未經授權之變更、偽造、篡改皆屬非法，違犯者將會被依法追訴。

TW5337586