



U74HC640

CMOS IC

OCTAL BUS TRANSCEIVERS WITH 3-STATE OUTPUTS

DESCRIPTION

The **U74AHC640** is a octal bus transceivers with 3-state outputs. It is designed for asynchronous two-way communication between data buses. Depending on the direction-control (DIR) input, data are transmitted from the A bus to the B bus or from the B bus to the A bus.

When \overline{OE} is high, the buses are effectively isolated. When \overline{OE} is low, the buses are enable.

FEATURES

- * Wide Supply Voltage Range from 2V to 6V
- * Typical t_{PD} of 8ns at 6V, $C_L=50pF$
- * Low Power Consumption, $I_{CC} = 8\mu A$ (Max) at 5.5V
- * $\pm 7.8mA$ Output Driver at 6V

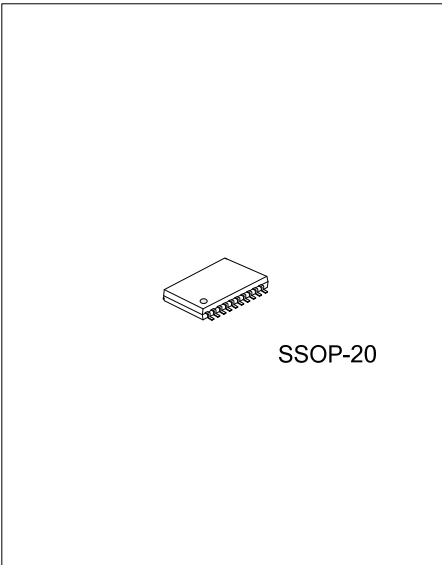

ORDERING INFORMATION

Ordering Number		Package	Packing
Lead Free	Halogen Free		
U74AHC640L-R20-R	U74AHC640G-R20-R	SSOP-20	Tape Reel
U74AHC640L-R20-T	U74AHC640G-R20-T	SSOP-20	Tube

<p>U74AHC640L-R20-R</p> <p>(1) Packing Type</p> <p>(2) Package Type</p> <p>(3) Lead Free</p>	<p>(1) R: Tape Reel, T: Tube</p> <p>(2) R20: SSOP-20</p> <p>(3) G: Halogen Free, L: Lead Free</p>
--	---

■ PIN CONFIGURATION

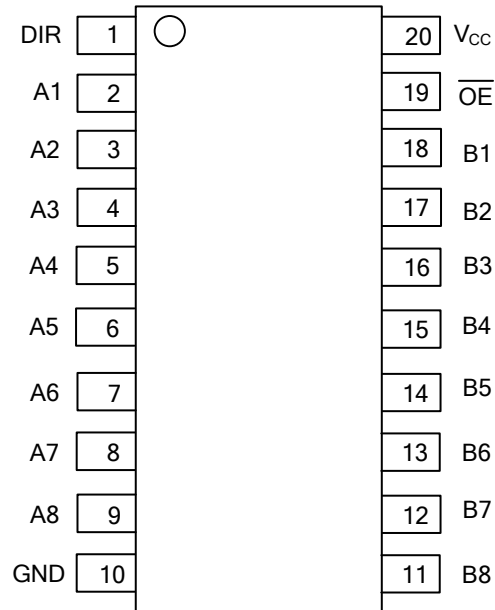

■ FUNCTION TABLE

INPUTS		OPERATION
\overline{OE}	DIR	
L	L	\overline{B} data to A bus
L	H	A data to B bus
H	X	Isolation

■ LOGIC DIAGRAM

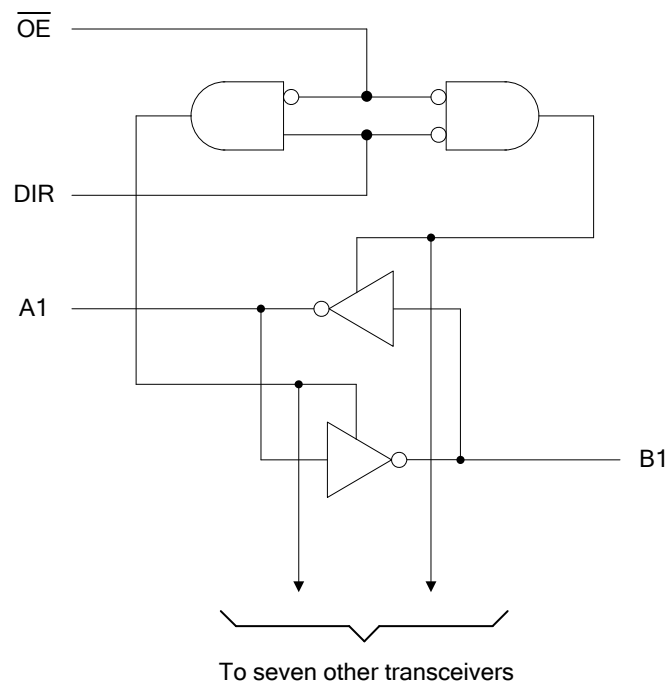

■ ABSOLUTE MAXIMUM RATING (unless otherwise specified)

PARAMETER	SYMBOL	RATINGS	UNIT
Supply Voltage	V_{CC}	-0.5~7	V
Input Voltage	V_{IN}	-0.5~7	V
Output Voltage	V_{OUT}	-0.5~ $V_{CC} + 0.5$	V
Input Clamp Current ($V_{IN} < 0$)	I_{IK}	± 20	mA
Output Clamp Current ($V_{OUT} < 0$, or $V_{OUT} > V_{CC}$)	I_{OK}	± 20	mA
Output Current	I_{OUT}	± 35	mA
V_{CC} or GND Current	I_{CC}	± 70	mA
Storage Temperature	T_{STG}	-65 ~ +150	°C

Note: 1. The input and output voltage ratings may be exceeded if the input and output current ratings are observed.
 2. Absolute maximum ratings are those values beyond which the device could be permanently damaged.
 Absolute maximum ratings are stress ratings only and functional device operation is not implied.

■ RECOMMENDED OPERATING CONDITIONS

PARAMETER	SYMBOL	CONDITIONS	MIN	TYP	MAX	UNIT
Supply Voltage	V_{CC}		2	5	6	V
High-Level Input Voltage	V_{IH}	$V_{CC} = 2V$	1.5			V
		$V_{CC} = 4.5V$	3.15			
		$V_{CC} = 6V$	4.2			
Low-Level Input Voltage	V_{IL}	$V_{CC} = 2V$			0.5	V
		$V_{CC} = 4.5V$			1.35	
		$V_{CC} = 6V$			1.8	
Input Voltage	V_{IN}		0		V_{CC}	V
Output Voltage	V_{OUT}		0		V_{CC}	V
Input Transition Rise or Fall Rate	$\Delta t/\Delta v$	$V_{CC} = 2V$			1000	ns/V
		$V_{CC} = 4.5V$			500	
		$V_{CC} = 6V$			400	
Operating Temperature	T_A		-40		85	°C

■ ELECTRICAL CHARACTERISTICS ($T_A = 25^\circ C$, unless otherwise specified)

PARAMETER	SYMBOL	TEST CONDITIONS	MIN	TYP	MAX	UNIT
High-Level Output Voltage	V_{OH}	$I_{OH} = -20\mu A, V_{CC} = 2V$	1.9	1.998		V
		$I_{OH} = -20\mu A, V_{CC} = 4.5V$	4.4	4.499		
		$I_{OH} = -20\mu A, V_{CC} = 6V$	5.9	5.999		
		$I_{OH} = -6mA, V_{CC} = 4.5V$	3.98	4.3		
		$I_{OH} = -7.8mA, V_{CC} = 6V$	5.48	5.8		
Low-Level Output Voltage	V_{OL}	$I_{OL} = 20\mu A, V_{CC} = 2V$		0.002	0.1	V
		$I_{OL} = 20\mu A, V_{CC} = 4.5V$		0.001	0.1	
		$I_{OL} = 20\mu A, V_{CC} = 6V$		0.001	0.1	
		$I_{OL} = 6mA, V_{CC} = 4.5V$		0.17	0.26	
		$I_{OL} = 7.8mA, V_{CC} = 6V$		0.15	0.26	
Input Leakage Current(DIR or \overline{OE})	$I_{I(LEAK)}$	$V_{IN} = V_{CC}$ or 0, $V_{CC} = 6V$		± 0.1	± 100	μA
High-Impedance State Current (A or B)	I_{OZ}	$V_{OUT} = V_{CC}$ or 0, $V_{CC} = 6V$		± 0.01	± 0.5	μA
Quiescent Supply Current	I_{CC}	$V_{IN} = V_{CC}$ or 0, $I_{OUT} = 0, V_{CC} = 6V$			8	μA
Input Capacitance (DIR or \overline{OE})	C_{IN}	$V_{IN} = V_{CC}$ or 0, $V_{CC} = 2V$ to 6V		3	10	pF

■ SWITCHING CHARACTERISTICS (T_A =25°C)

C_L=50pF, R_L=1kΩ

PARAMETER	SYMBOL	TEST CONDITIONS	MIN	TYP	MAX	UNIT
Propagation Delay from A to B or B to A	t _{PD}	V _{CC} =2V		29	105	ns
		V _{CC} =4.5V		10	21	
		V _{CC} =6V		8	18	
Enable Times from \overline{OE} to A or B	t _{EN}	V _{CC} =2V		109	230	ns
		V _{CC} =4.5V		27	46	
		V _{CC} =6V		20	39	
Disable Times from \overline{OE} to A or B	t _{DIS}	V _{CC} =2V		40	150	ns
		V _{CC} =4.5V		18	30	
		V _{CC} =6V		16	26	
Output Rise or fall Time	t _T	V _{CC} =2V		20	60	ns
		V _{CC} =4.5V		8	12	
		V _{CC} =6V		6	10	

C_L=150pF, R_L=1kΩ

PARAMETER	SYMBOL	TEST CONDITIONS	MIN	TYP	MAX	UNIT
Propagation Delay from A to B or B to A	t _{PD}	V _{CC} =2V		44	190	ns
		V _{CC} =4.5V		14	38	
		V _{CC} =6V		11	33	
Enable Times from \overline{OE} to A or B	t _{EN}	V _{CC} =2V		124	315	ns
		V _{CC} =4.5V		31	63	
		V _{CC} =6V		23	54	
OUTPUT rise or fall Time	t _T	V _{CC} =2V		45	210	ns
		V _{CC} =4.5V		17	42	
		V _{CC} =6V		13	36	

■ OPERATING CHARACTERISTICS (T_A =25°C)

PARAMETER	SYMBOL	TEST CONDITIONS	TYP	UNIT
Power Dissipation Capacitance	C _{PD}	No load	40	pF

■ TEST CIRCUIT AND WAVEFORMS

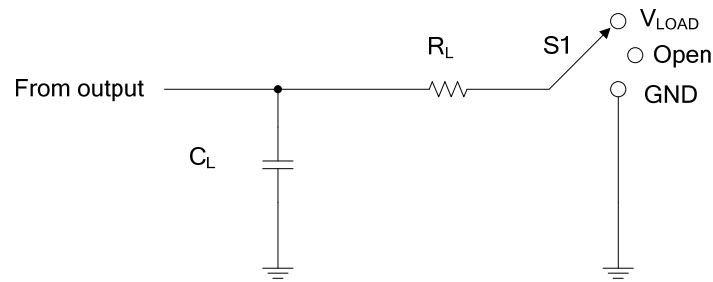

Test Circuit

TEST	S1
t_{PLH}/t_{PHL}	Open
t_{PLZ}/t_{PZL}	V_{LOAD}
t_{PHZ}/t_{PZH}	GND

V_{CC}	Input		V_M	V_{LOAD}	C_L	R_L	V_{Δ}
	V_{IN}	t_R, t_F					
$3.3V \pm 0.3V$	V_{CC}	$\leq 3ns$	$V_{CC}/2$	V_{CC}	50pF	1k Ω	0.3V
					150pF		
$5V \pm 0.5V$	V_{CC}	$\leq 3ns$	$V_{CC}/2$	V_{CC}	50pF	1k Ω	0.5V
					150pF		

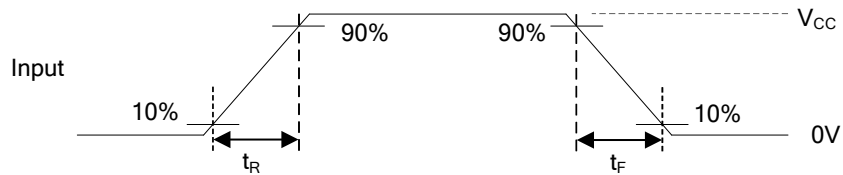

Voltage Waveforms Input Rise and Fall Times

■ TEST CIRCUIT AND WAVEFORMS(Cont.)

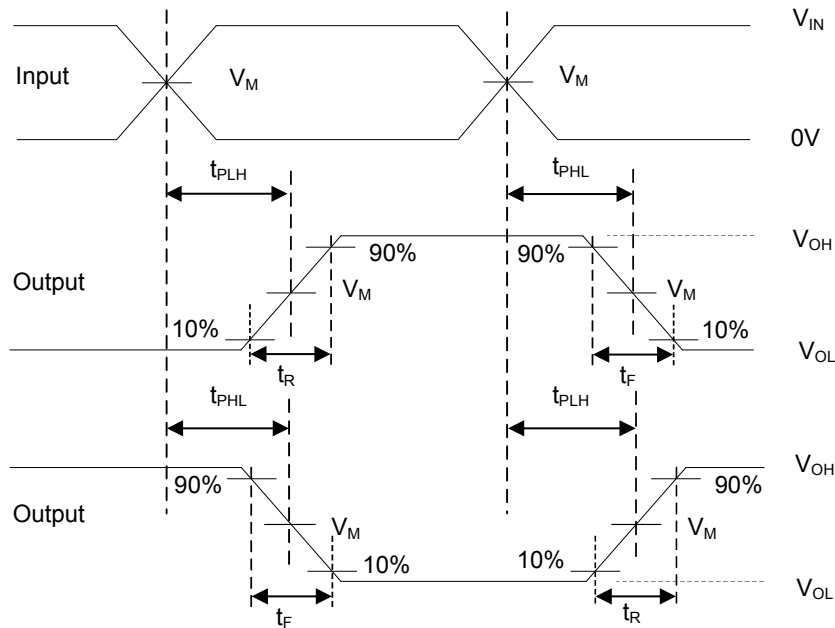

Voltage Waveforms Propagation Delay and Output Transition Times

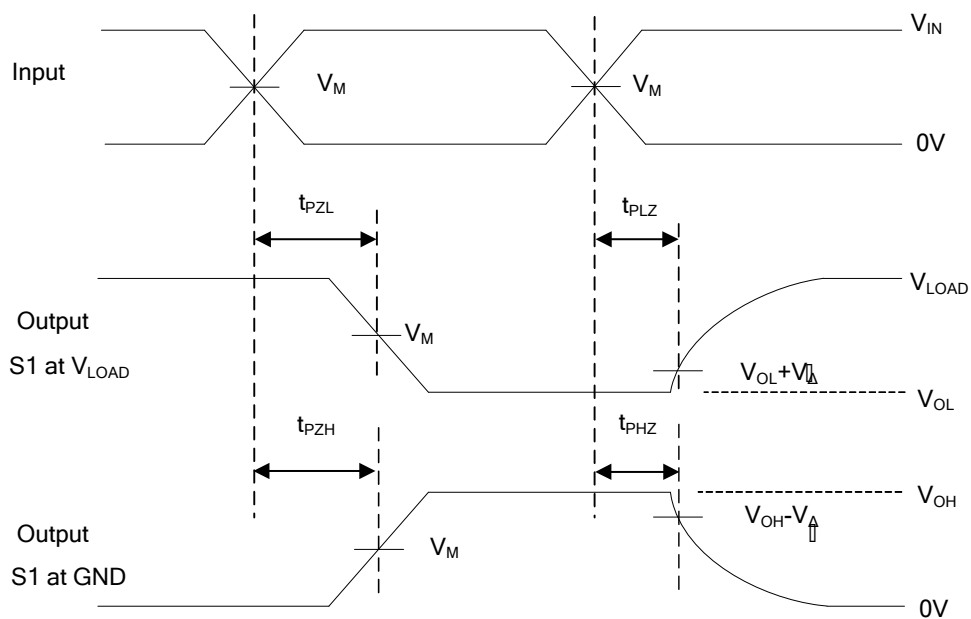

VOLTAGE WAVEFORMS ENABLE AND DISABLE TIMES

- Notes:
1. C_L includes probe and jig capacitance.
 2. All input pulses are supplied by generators having the following characteristics: $P_{RR} \leq 1\text{MHz}$, $Z_O = 50\Omega$, $t_R = 6\text{ns}$, $t_F = 6\text{ns}$.
 3. t_{PLH} and t_{PHL} are the same as t_{PD} .
 4. t_{PLZ} and t_{PHZ} are the same as t_{DIS} .
 5. t_{PZH} and t_{PZL} are the same as t_{EN} .

UTC assumes no responsibility for equipment failures that result from using products at values that exceed, even momentarily, rated values (such as maximum ratings, operating condition ranges, or other parameters) listed in products specifications of any and all UTC products described or contained herein. UTC products are not designed for use in life support appliances, devices or systems where malfunction of these products can be reasonably expected to result in personal injury. Reproduction in whole or in part is prohibited without the prior written consent of the copyright owner. The information presented in this document does not form part of any quotation or contract, is believed to be accurate and reliable and may be changed without notice.