

Rack-mounted Power Transducers 17-RACK

THERMOCOUPLE CONVERTER

(fast response)

Functions & Features

- Accepting direct input from a thermocouple and providing a standard process signal
- 5-segment linearization
- Burnout protection
- High-accuracy cold junction compensation

Typical Applications

- High-accuracy cold junction compensation benefits narrow span measurements
- 0.1 μ A burnout sensing enables long distance transmission with minimum offset drifts
- Electric furnace (isolation)
- No burnout type can connect to a single T/C in parallel with a recorder

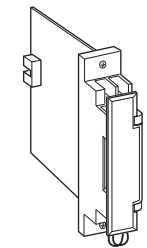

MODEL: 17TK-[1]6-R[2]

ORDERING INFORMATION

- Code number: 17TK-[1]6-R[2]
- Specify a code from below for each [1] and [2]. (e.g. 17TK-26-R/BL)
- Temperature range (e.g. 0 - 800°C)

[1] INPUT THERMOCOUPLE

- 1: (PR) (Usable Range 0 to 1760°C, 32 to 3200°F)
- 2: K (CA) (Usable range -270 to +1370°C, -454 to +2498°F)
- 3: E (CRC) (Usable range -270 to +1000°C, -454 to +1832°F)
- 4: J (IC) (Usable range -210 to +1200°C, -346 to +2192°F)
- 5: T (CC) (Usable range -270 to +400°C, -454 to +752°F)
- 6: B (RH) (Usable range 0 to 1820°C, 32 to 3308°F)
- 7: R (Usable range -50 to +1760°C, -58 to +3200°F)
- 8: S (Usable range -50 to +1760°C, -58 to +3200°F)
- N: N (Usable range -270 to +1300°C, -454 to +2372°F)
- 0: Specify

OUTPUT

Voltage

6: 1 - 5 V DC (Load resistance 2000 Ω min.)

POWER INPUT

DC Power

R: 24 V DC
(Operational voltage range 24 V \pm 10 %, ripple 10 %p-p max.)

[2] OPTIONS

Burnout

blank: Upscale burnout
/BL: Downscale burnout
/BN: No burnout

GENERAL SPECIFICATIONS

Construction: Rack-mounted; terminal access via screw terminals on the front and connector on the rear; terminal cover provided

Connection:

Input: M3.5 screw terminals (torque 0.8 N·m)

Output: Connector

Power input: Supplied from connector

Screw terminal: Nickel-plated steel

Isolation: Input to output to power

Zero adjustment: -5 to +5 % (front)

Span adjustment: 95 to 105 % (front)

Linearization: Standard

Cold junction compensation: CJC sensor attached to the input terminals (B thermocouple is without CJC as standard)

INPUT SPECIFICATIONS

Input resistance: 20 k Ω minimum

Burnout sensing: 0.1 μ A

Minimum span: 3 mV

Offset: Max. 1.5 times span

Minimum span (in °C)

(PR): 370°C

K (CA): 75°C

E (CRC): 50°C

J (IC): 60°C

T (CC): 75°C

B (RH): 780°C

R: 360°C

S: 380°C

N: 110°C

Minimum span (in °F)

(PR): 670°F

K (CA): 140°F

- E (CRC): 90°F
- J (IC): 110°F
- T (CC): 140°F
- B (RH): 1410°F
- R: 650°F
- S: 690°F
- N: 200°F

For the temperatures that range below 0°C, the transmitter may partially not satisfy the described accuracy. Consult factory.

INSTALLATION

- Current consumption:** Approx. 35 mA
- Operating temperature:** -5 to +55°C (23 to 131°F)
- Operating humidity:** 40 to 85 % RH (non-condensing)
- Mounting:** Standard Rack 17BXE
- Weight:** 150 g (0.33 lb)

PERFORMANCE in percentage of span

- Accuracy:** ±0.4 % (at over 400°C or 750°F for R, S and PR; over 770°C or 1420°F for B)
- Cold junction compensation error**
(at 20°C ±10°C or 68°F ±18°F)
- K, E, J, T, N:** ±0.5°C or ±0.9°F
- S, R, PR:** ±1°C or ±1.8°F
- Temp. coefficient:** ±0.015 %/°C (±0.008 %/°F)
(at over 400°C or 750°F for R, S and PR; over 770°C or 1420°F for B)
- Response time:** Approx. 25 msec. (0 - 90 %)
- Burnout response:** ≤ 10 sec.
- Line voltage effect:** ±0.1 % over voltage range
- Insulation resistance:** ≥ 100 MΩ with 500 V DC
- Dielectric strength:** 1500 V AC @ 1 minute
(input to output or power)
500 V AC @ 1 minute (output to power)
1500 V AC @ 1 minute (input or output or power to ground)

DIMENSIONS unit: mm (inch)

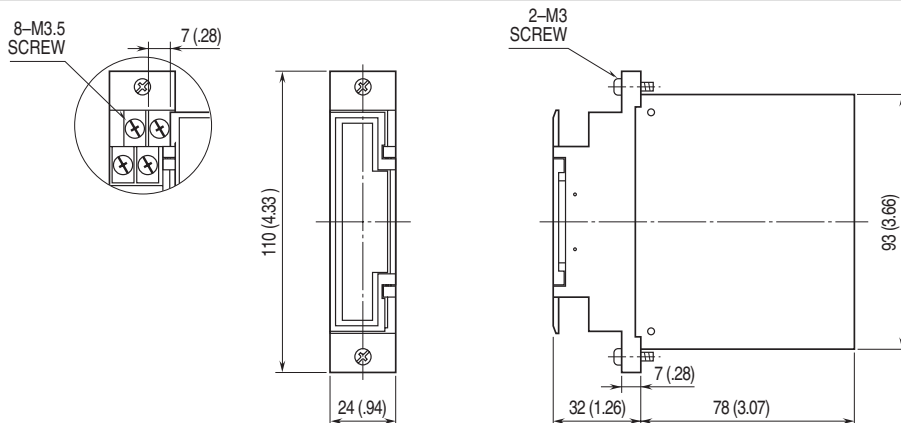

TERMINAL ASSIGNMENTS

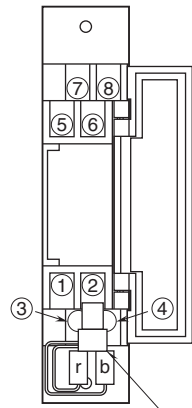

CJC SENSOR (model: CJM)

SCHEMATIC CIRCUITRY & CONNECTION DIAGRAM

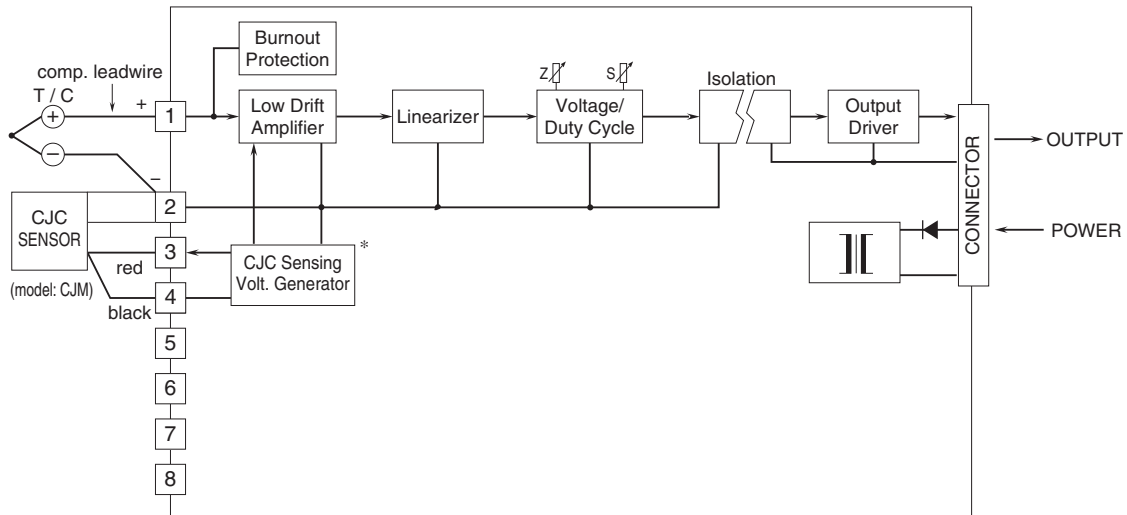

*Deleted with Option /B thermocouple.



Specifications are subject to change without notice.