

# EMB-H61B

Mini-ITX Embedded Motherboard with Intel® 2nd/3rd Generation Core™ i7/ i5/ i3 Processor

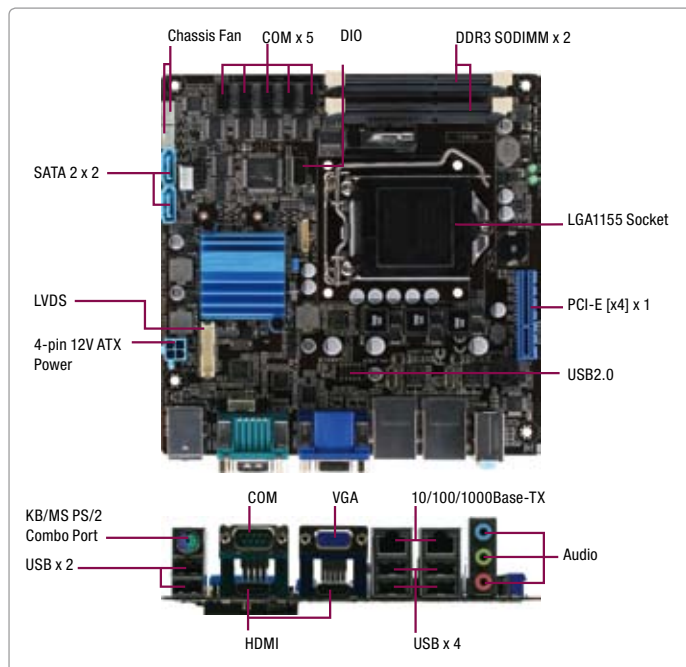

## Features

- Intel® Socket 1155 for 2nd/3rd Generation Core™ Processor up to 65W
- Intel® H61 Express Chipset
- DDR3 1066/1333 MHz SODIMM x 2, Max. 16GB
- VGA, HDMI x 2 , LVDS Dual Independent Display
- Realtek 8111F x 2, Gigabit Ethernet x 2
- PCI-E [x4] x 1, Full-size Mini Card + SIM Card x 1
- TPM Infineon SLB9635 TT 1.2



## Specifications

System	
Form Factor	Mini-ITX
Processor	LGA1155 socket for Intel® 2nd/3rd Generation Core™ i7/ i5/ i3/ Pentium®/ Celeron® Processors, Supports Intel® 22/32 nm CPU up to 65W. (65W CPU supported without Turbo Boost mode)
System Memory	SODIMM x 2, Max. 16GB, DDR3 1333/1066 MHz Non-ECC, Un-buffered Memory
Chipset	Intel® H61 Express Chipset
I/O Chipset	Fintek F81866D-1
Ethernet	Realtek 8111F, Gigabit Ethernet, RJ-45 x 2
BIOS	64Mbit Flash ROM, AMI BIOS
Wake On LAN	Yes (WOL/ PXE)
Watchdog Timer	1~255 steps by software program
H/W Status Monitoring	Temperature Monitor on CPU/ System, Voltage Monitor on Vcore/5V/VBAT/12V, Fan Monitor on CPU/ Chassis
Expansion Interface	PCIe 2.0[x4] x 1, Full-size Mini Card(PCIe +USB) + SIM Card x 1
Battery	Lithium battery
Power Requirement	4-pin 12V Power connector x 1
Power Consumption (Typical)	Intel® Core™ i7-3770S Processor, DDR3 1600 8GB x 2, 8.1A@12V
Board Size	6.7" x 6.7" (170mm x 170mm)
Gross Weight	1.1 lb (0.5 Kg)
Operation Temperature	32°F ~ 131°F (0°C ~ 55°C)
Storage Temperature	-4°F ~ 158°F (-20°C ~ 70°C)
Operation Humidity	10% ~ 80% RH, non-condensing
MTBF (Hours)	211,000
Display	
Graphic Engine	Intel® Graphics Media Accelerator
Resolution	Up to 2048 x 1536 @75 Hz for VGA Up to 1920 x 1200 @60 Hz for HDMI Up to 1920 x 1200 @60 Hz, Dual Channel 18/24-bit for LVDS
Output Interface	VGA, HDMI x 2, LVDS
I/O	
Storage	SATA 3Gb/s x 2, CF-SATA (SATA+IDE) x 1
Serial Port	RS-232 (on back panel) x 5, RS-232/422/485 x 1, supports optional 5V/12V/RI (on mid-board)
Universal Serial Bus	USB2.0 x 8, 2 ports on mid-board, 6 ports on back panel
Digital I/O	8-bit programmable (4-in / 4-out)
PS/2 Port	keyboard / Mouse with PS/2 connector x 1
Audio	Line-in, Mic-in, Line-out

## Packing List

- I/O Shield
- SATA Cable x 2
- SATA Power Cable
- Product CD
- EMB-H61B

# EMB-H61B

## Dimension

Unit: mm

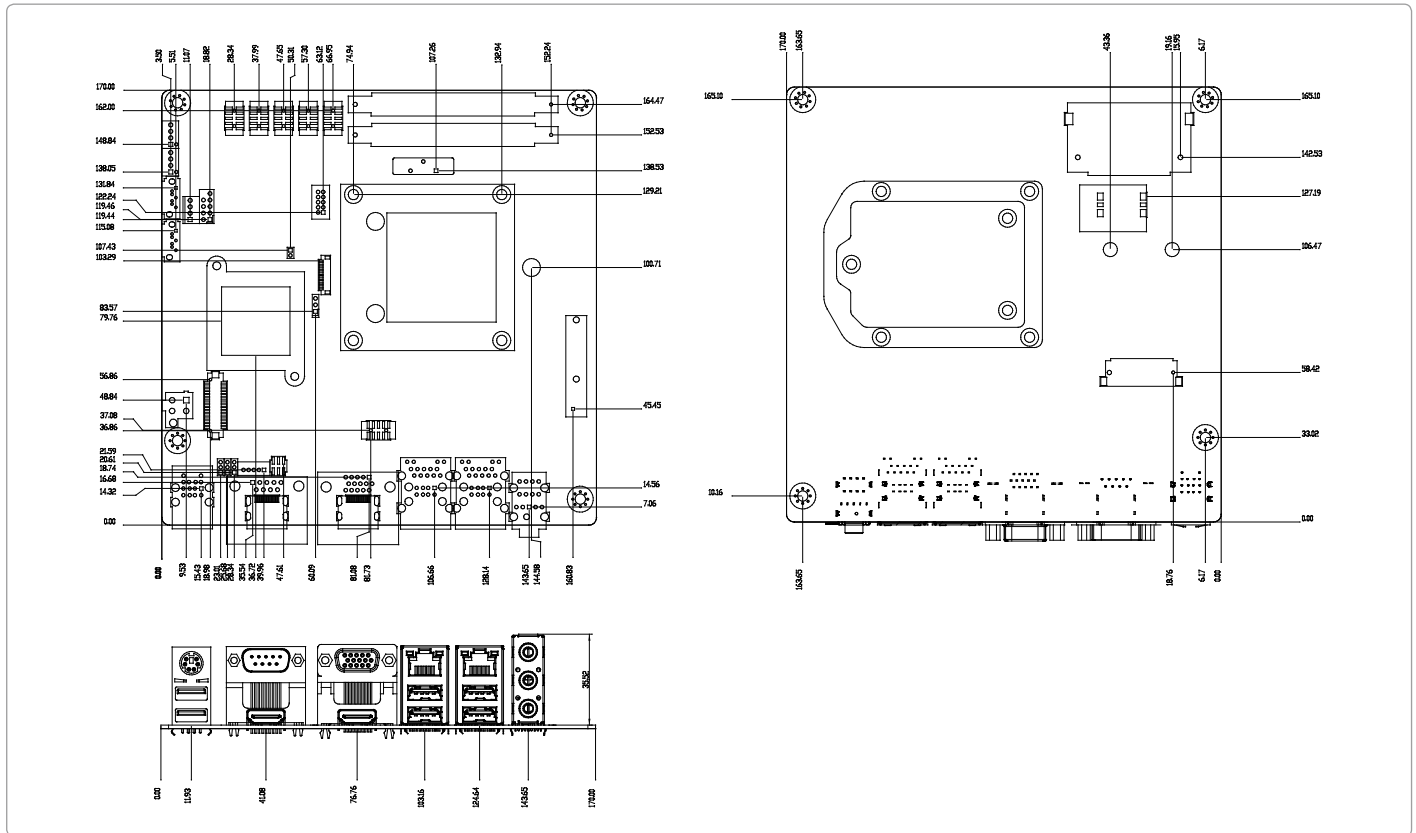

## Ordering Information

Part Number	CPU	RAM	Fan/ Fanless	Display	Storage	LVDS	LAN	USB	RS-232	RS-232/422/485	Expansion Slot	Power	Temp.
EMB-H61B-A10	Socket	SODIMM	Fan	VGA, HDMI x 2	SATA2 x 2 CF-SATA x 1	18/24-bit	GbE x 2	USB 2.0 x 8	5	1	PCIe [x4] x 1 Full-size Mini Card + SIM Card	ATX	0°C ~ 55°C

## Optional Accessories

- **1709100201**  
USB 2.0 Cable
- **1701100206**  
COM Port Cable
- **17592H61A0**  
CPU Cooler
- **1709070800**  
SATA Cable