

BLC SERIES LOW PRESSURE COMPACT SENSORS

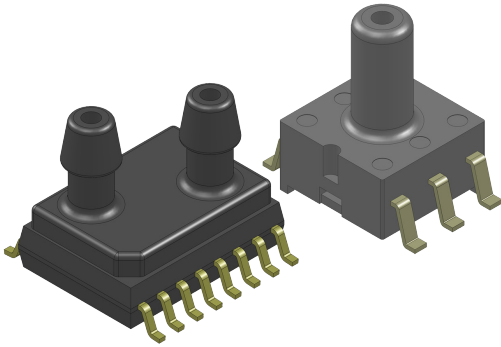

Features

- 0 to 1 inH₂O to 0 to 30 inH₂O and 15 PSIA Pressure Ranges
- uPower Low Supply Voltage (0.9V to 1.8V)
- 0.1% Linearity Typical
- Improved Front to Back Linearity
- Less Position Sensitivity
- Improved Warm-Up Shift Distribution
- Parylene Coating Available Upon Request

Applications

- Medical Instrumentation
- Environmental Controls
- HVAC
- Portable / Hand Held Devices

General Description

The BLC Series Basic Low Pressure Compact Sensor is based on All Sensors' CoBeam²™ Technology. The device provides a high output signal at a low operating voltage and reduces the overall supply voltage while maintaining comparable output levels to traditional equivalent basic sensing elements. This lower supply voltage gives rise to improved warm-up shift while the CoBeam² Technology itself reduces package stress susceptibility resulting in improved overall long term stability. The technology also vastly improves position sensitivity compared to conventional single die devices.

This series is intended for use with non-corrosive, non-ionic working fluids such as air, dry gases and the like. The output is also ratio-metric to the supply voltage and is operable from 0.9 to 1.8 volts DC.

Standard Pressure Ranges

| Device | Operating Range | Proof Pressure | Burst Pressure |
|----------|-----------------------------------|---------------------------------|----------------------------------|
| BLC-L01D | ±1 inH ₂ O (250 Pa) | 100 inH ₂ O (25 KPa) | 150 inH ₂ O (37 KPa) |
| BLC-L05D | ±5 inH ₂ O (1,250 Pa) | 200 inH ₂ O (50 KPa) | 300 inH ₂ O (75 KPa) |
| BLC-L10D | ±10 inH ₂ O (2,500 Pa) | 200 inH ₂ O (50 KPa) | 300 inH ₂ O (75 KPa) |
| BLC-L20D | ±20 inH ₂ O (5,000 Pa) | 200 inH ₂ O (50 KPa) | 500 inH ₂ O (125 KPa) |
| BLC-L30D | ±30 inH ₂ O (7,500 Pa) | 200 inH ₂ O (50 KPa) | 800 inH ₂ O (200 KPa) |
| BLC-015A | 0 to 15 PSIA (1 barA) | 60 PSI (4 barA) | 120 PSI (8 barA) |

Pressure Sensor Maximum Ratings

| | |
|---------------------------------------|--------|
| Supply Voltage (Vs) | 3 Vdc |
| Common Mode Pressure | 5 psig |
| Lead Temperature (soldering 2-4 sec.) | 270 °C |

Environmental Specifications

| | | |
|--------------------|-----------|---------------------------------|
| Temperature Ranges | Operating | -25 to 85 °C |
| | Storage | -40 to 125 °C |
| Humidity Limits | | 0 to 95% RH (non condensing) |

Performance Characteristics for BLC Series

ALL PARAMETERS ARE MEASURED AT 1.8V EXCITATION AND ROOM TEMPERATURE UNLESS OTHERWISE SPECIFIED. PRESSURE MEASUREMENTS ARE WITH POSITIVE PRESSURE APPLIED TO PORT B (THE ONLY PORT FOR THE SINGLE PORT CONFIGURATION.)

| Parameter | Min | Typ | Max | Units | Notes |
|--|------|-------|-------|--------|-------|
| Output Span (FSS) | | | | | 4 |
| L01D | 4.5 | 8.0 | 11.5 | mV | |
| L05D | 13.5 | 24.0 | 34.5 | mV | |
| L10D | 18.0 | 32.0 | 46.0 | mV | |
| L20D | 22.0 | 38.0 | 55.0 | mV | |
| L30D | 25.0 | 42.0 | 60.0 | mV | |
| 015A | 43.2 | 62.1 | 81.0 | mV | |
| Offset Voltage | | | | | - |
| L01D, L05D, L10D, L20D, L30D (@ Zero Diff. Pressure) | | - | ±10.0 | mV | |
| 015A (@ 0 PSIA) | - | - | ±15.0 | mV | |
| Offset Temperature Shift (0°C-70°C) | - | ±30.0 | - | µV/°C | 1 |
| Offset Warm-up Shift | - | ±30.0 | - | µV | 2, 6 |
| Offset Position Sensitivity (1g) | - | ±20.0 | - | µV | - |
| Linearity, Hysteresis Error | - | 0.10 | ±0.50 | %FSS | 3 |
| Response Time (10% to 90% Pressure Response) | - | 100 | - | µS | - |
| Front to Back Linearity | - | 0.25 | - | %FSS | 5 |
| Temperature Effect on Resistance (0°C-70°C) | - | 2800 | - | ppm/°C | - |
| Temperature Effect on Span (0°C-70°C) | - | -2000 | - | ppm/°C | - |
| Input Resistance | | | | | - |
| L01D, L05D, L10D, L20D, L30D | - | 3.4 | - | kΩ | |
| 015A | - | 5.0 | - | kΩ | |
| Output Resistance | | | | | - |
| L01D, L05D, L10D, L20D, L30D | - | 3.4 | - | kΩ | |
| 015A | - | 5.0 | - | kΩ | |

Specification Notes

NOTE 1: SHIFT IS RELATIVE TO 25°C.

NOTE 2: SHIFT IS WITHIN THE FIRST HOUR OF EXCITATION APPLIED TO THE DEVICE.

NOTE 3: MEASURED AT ONE-HALF FULL SCALE RATED PRESSURE USING BEST STRAIGHT LINE CURVE FIT.

NOTE 4: THE SPAN IS THE ALGEBRAIC DIFFERENCE BETWEEN FULL SCALE OUTPUT VOLTAGE AND THE OFFSET VOLTAGE.

$$\text{Lin}_{FB} = \left(\left| \frac{\text{Span}_{\text{PortB}}}{\text{Span}_{\text{PortA}}} \right| - 1 \right) \cdot 100\%$$

NOTE 5: FRONT-BACK LINERITY COMPUTED AS:

NOTE 6: TYPICAL WARM UP OF CHARACTERISTICS AS SHOWN BELOW.

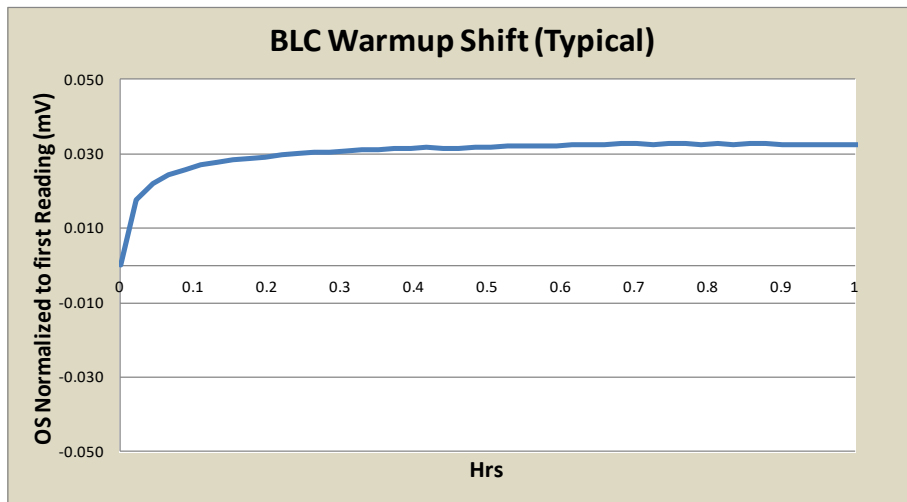

How To Order

Refer to Table 1 for configuring a standard base part number which includes the pressure range and package.

Example P/N with options: BLC-L01D-D4

Table 1 - How to Configure a Part Number

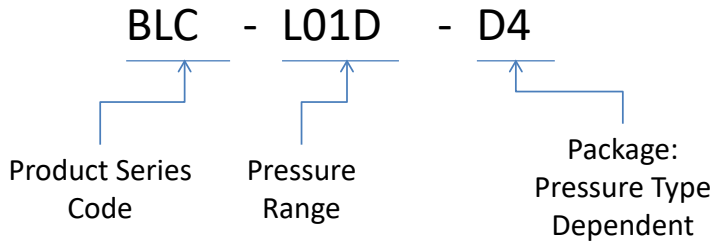

Where:

Pressure Range (D1, D3, D4 Packages — Differential Only): L01D, L05D, L10D, L20D, L30D

Pressure Range (U2, U3 Package — Gage Only): L01D, L05D, L10D, L20D, L30D

Pressure Range (U4 Package — Absolute Only): 015A

(Consult with factory for parylene coating)

Product Identification on backside of device

All products are labeled via laser marking as seen in Figure 1.

Figure 2 details how to interpret the part marking code. Low pressure ranges from 1 to 30 inH₂O are specified with code "L" and 15psi absolute high pressure products with code "H".

The pressure range will be indicated on the same line as the lot number before the starting character "R".

Example: BLC-L01D-D4

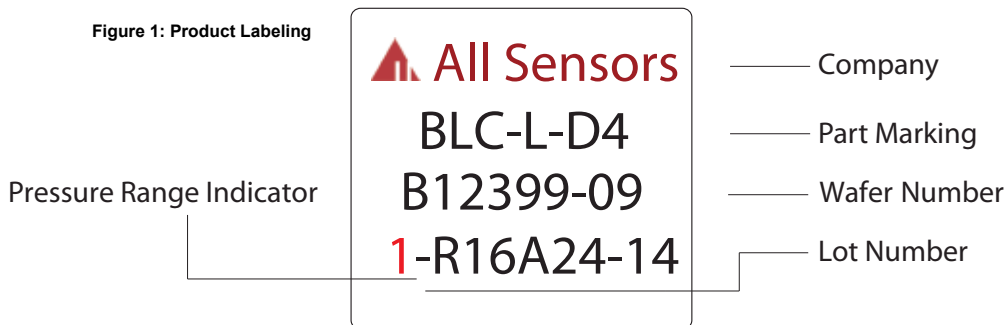

Product Identification on backside of device (Cont'd)

Figure 2: Part Marking

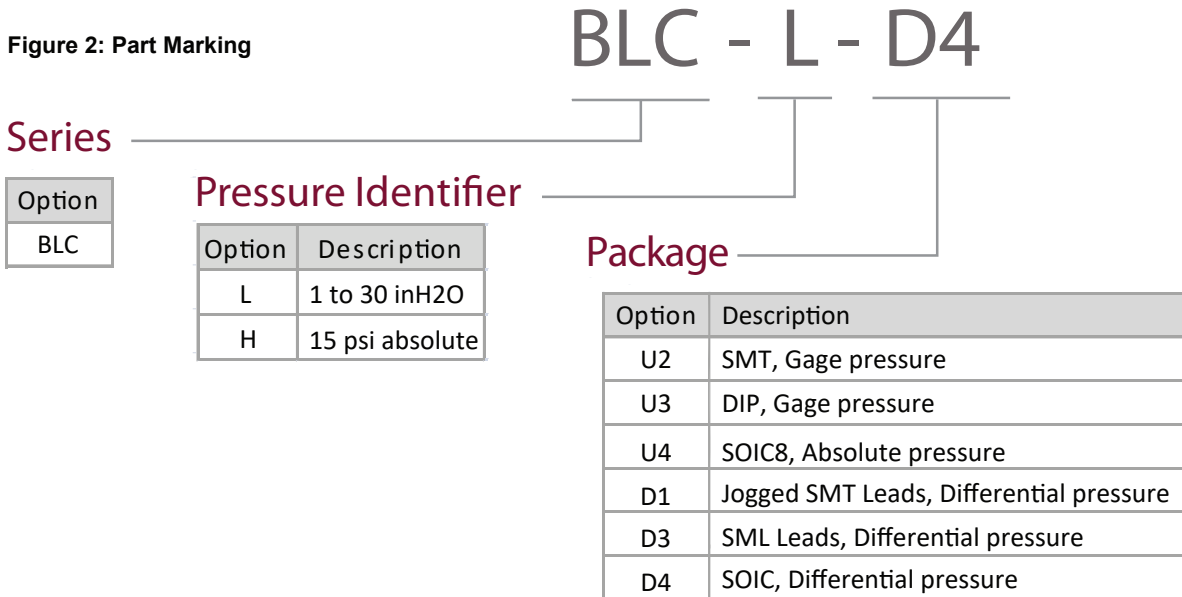

Soldering Recommendations

- 1) Solder parts as a second operation only.
- 2) For D4 package post reflow, wait for 72 hrs before performing any calibration operations.
- 3) For all other packages post reflow, wait for 36 hrs before performing any calibration operations.
- 4) Perform spot cleaning as necessary only by hand. DO NOT wash or submerge device in cleaning liquid.

Package Drawings

U2 Package

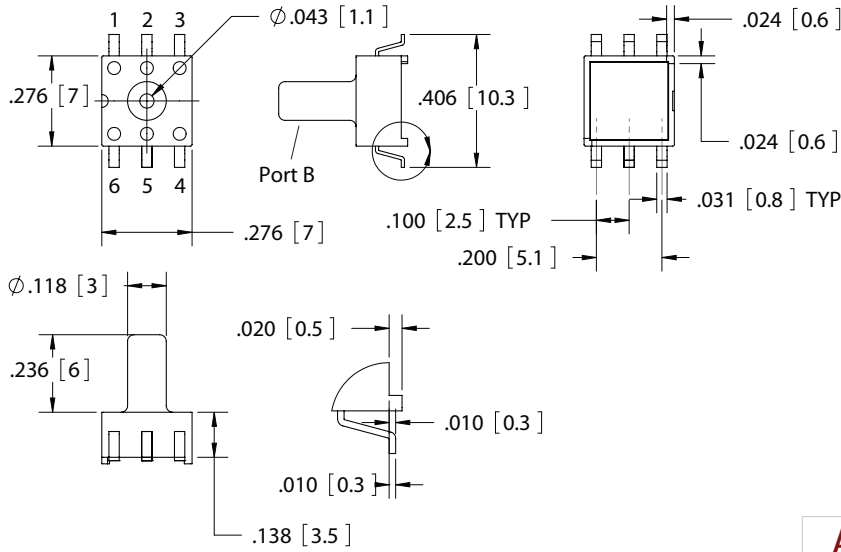

| Pin | Definition |
|-----|------------|
| 1 | +GND |
| 2 | +Vout |
| 3 | Vs |
| 4 | N/C |
| 5 | -Vout |
| 6 | -GND |

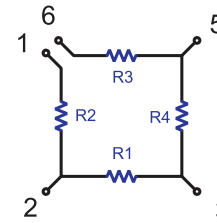

NOTES

- 1) Dimensions are in inches [mm].
- 2) For suggested pad layout, see drawing: PAD-24
- 3) Pins 1 and 6 must be connected for Gnd.

All Sensors

TITLE: U-Series Package

SIZE FILE NAME
A U2 Package

U3 Package

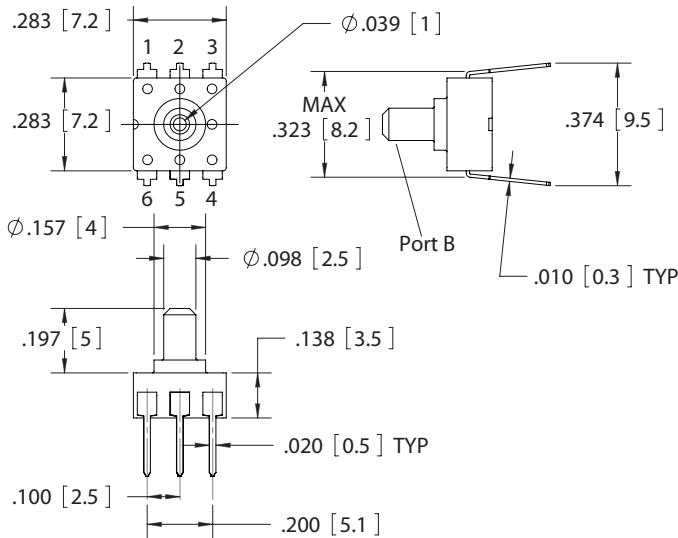

| Pin | Definition |
|-----|------------|
| 1 | N/C |
| 2 | -Vout |
| 3 | -GND |
| 4 | +GND |
| 5 | +Vout |
| 6 | Vs |

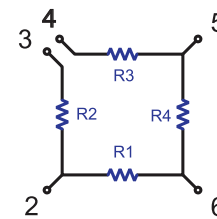

NOTES

- 1) Dimensions are in inches [mm].
- 2) For suggested pad layout, see drawing: PAD-25
- 3) Pins 3 and 4 must be connected for Gnd.

All Sensors

TITLE: U-Series Package

SIZE FILE NAME
A U3 Package

Package Drawings (Cont'd)

U4 Package

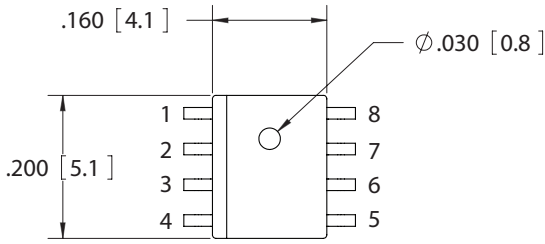

| Pin | Definition |
|-----|------------|
| 1 | N/C |
| 2 | +Vout |
| 3 | N/C |
| 4 | +GND |
| 5 | -GND |
| 6 | -Vout |
| 7 | N/C |
| 8 | Vs |

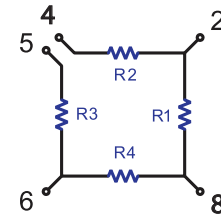
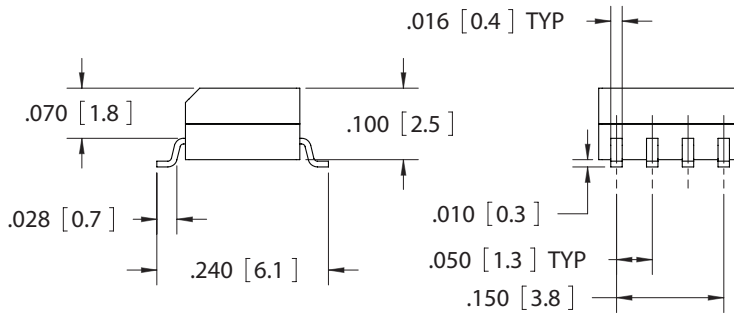

NOTES

- 1) Dimensions are in mm [inches].
- 2) Offered for 015A only.
- 3) For suggested pad layout, see drawing: PAD-26
- 4) Pins 4 and 5 must be connected for Gnd.

All Sensors

TITLE: U-Series Package

SIZE FILE NAME
A U4 Package

Package Drawings (Cont'd)

D1 Package

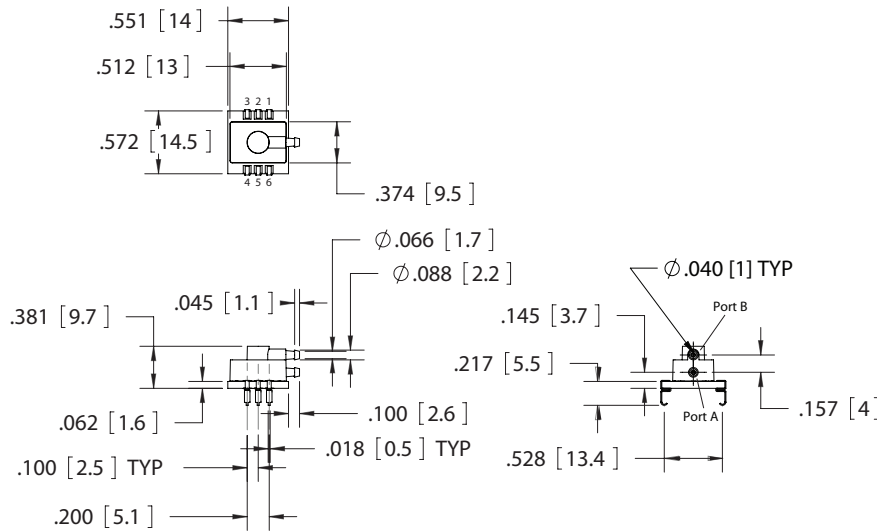

| Pin | Definition |
|-----|------------|
| 1 | +GND |
| 2 | +Vout |
| 3 | Vs |
| 4 | N/C |
| 5 | -Vout |
| 6 | -GND |

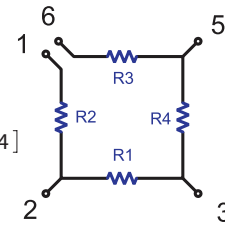

NOTES

- 1) Dimensions are in inches [mm].
- 2) For suggested pad layout, see drawing: PAD-20.
- 3) Pins 1 and 6 must be connected for Gnd.

All Sensors

TITLE: D-Series Package

SIZE FILE NAME
A D1 Package

D3 Package

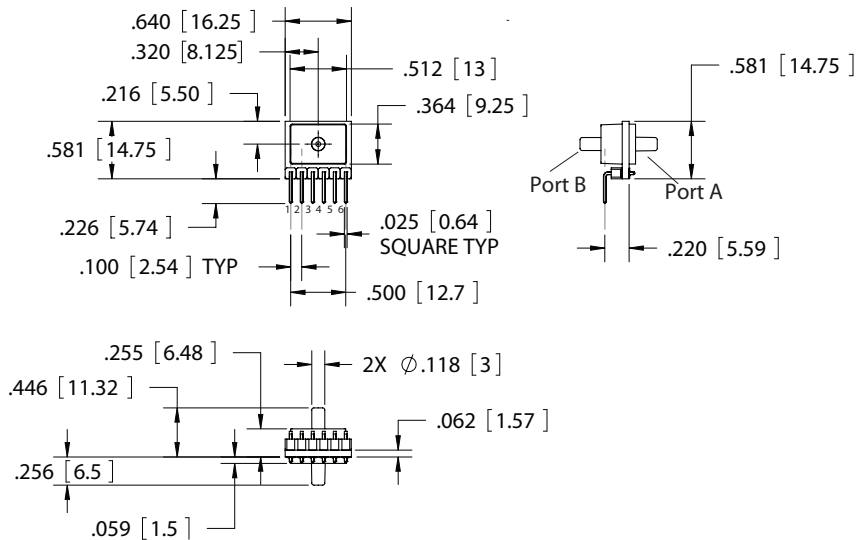

| Pin | Definition |
|-----|------------|
| 1 | +GND |
| 2 | +Vout |
| 3 | Vs |
| 4 | N/C |
| 5 | -Vout |
| 6 | -GND |

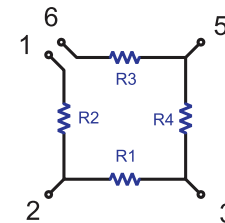

NOTES

- 1) Dimensions are in inches [mm].
- 2) For suggested pad layout, see drawing: PAD-21.
- 3) Pins 1 and 6 must be connected for Gnd.

All Sensors

TITLE: D-Series Package

SIZE FILE NAME
A D3 Package

D4 Package

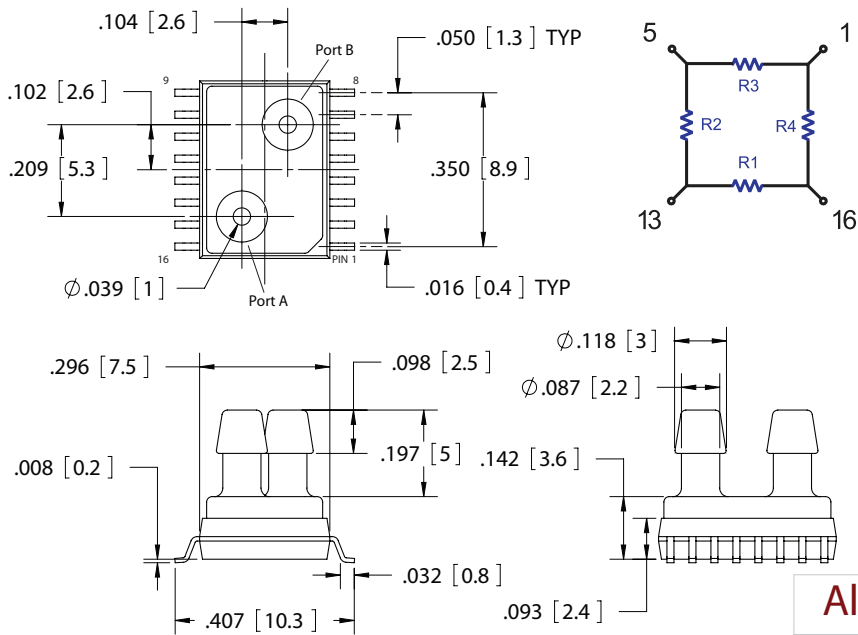

| Pin | Definition |
|-----|------------|
| 1 | -Vout |
| 2 | N/C |
| 3 | N/C |
| 4 | N/C |
| 5 | GND |
| 6 | N/C |
| 7 | N/C |
| 8 | N/C |
| 9 | N/C |
| 10 | N/C |
| 11 | N/C |
| 12 | N/C |
| 13 | +Vout |
| 14 | N/C |
| 15 | N/C |
| 16 | Vs |

NOTES

- 1) Dimensions are in inches [mm].
- 2) For suggested pad layout, see drawing: PAD-22.

All Sensors

| | |
|----------|------------------|
| TITLE: | D-Series Package |
| SIZE | FILE NAME |
| A | D4 Package |

Pressure Tubing Recommendations

| Tubing Number | Part Number | Description |
|---------------|-------------|---|
| 1 | ABX00002 | Versilic SPX-50, 1/16" I.D. x 1/8" O.D. x 1/32" Wall |
| 2 | ABX00004 | Versilic SPX-50, 3/32" I.D. x 5/32" O.D. x 1/32" Wall |

| Package | Tubing Number |
|---------|---------------|
| D1 | 1 |
| D3 | 2 |
| D4 | 2 |
| U2 | 2 |
| U3 | 1 |
| U4 | N/A |

Packaging

TUBE



ALL PRODUCTS FOUND IN THIS DATASHEET ARE PACKAGED IN TUBES WITH PIN 1 ORIENTED TOWARDS THE WHITE STOPPER.

Suggested Pad Layout

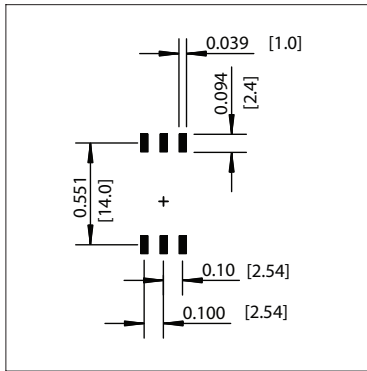

PAD-20

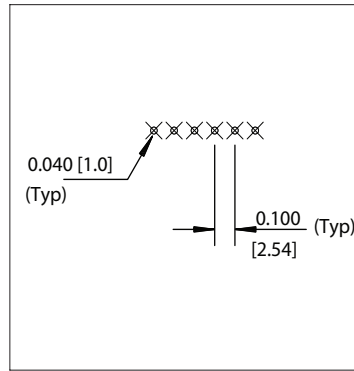

PAD-21

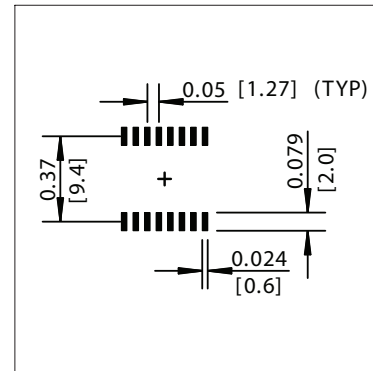

PAD-22

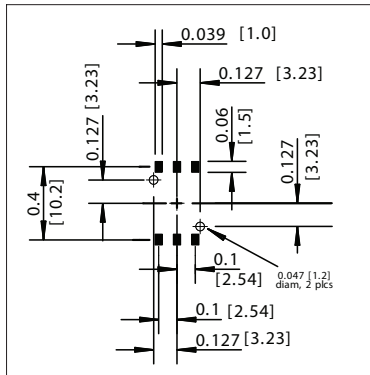

PAD-24

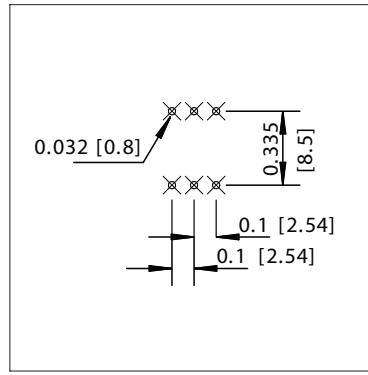

PAD-25

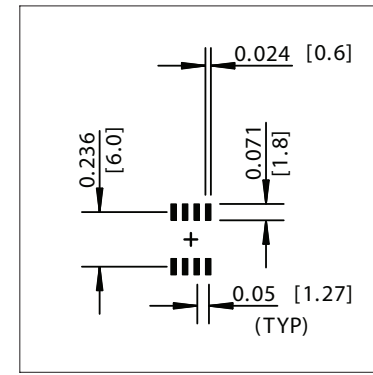

PAD-26

Dimensions are in inches [mm].

All Sensors reserves the right to make changes to any products herein. All Sensors does not assume any liability arising out of the application or use of any product or circuit described herein, neither does it convey any license under its patent rights nor the rights of others.