

---

# HD26C32A

## Quadruple Differential Line Receivers With 3 State Outputs

# HITACHI

ADE-205-575 (Z)  
1st. Edition  
Dec. 2000

---

### Description

The HD26C32A provides differential line receivers which realize low power dissipation by CMOS process. The device has four receivers which meet the requirements of EIA standard RS-422A and RS-423A in a 16 pin package.

The enable function is common to all four receivers and offers a choice of active high or active low inputs. Fail safe design ensures that if the inputs are open the outputs will always be high.

### Features

- Low power dissipation with CMOS process
- Meets EIA standard RS-422A/423A
- Input sensitivity:  $\pm 0.2V$  (In the range of  $\pm 7 V$  of common mode input voltage)
- Propagation delay time: 19 ns typ
- Input hysteresis width: 60 mV typ
- Three state outputs
- Differential Inputs are includes fail safe circuit
- Power up and power down protection
- Pin to pin compatible with HD26LS32/32A

# HD26C32A

## Pin Arrangement

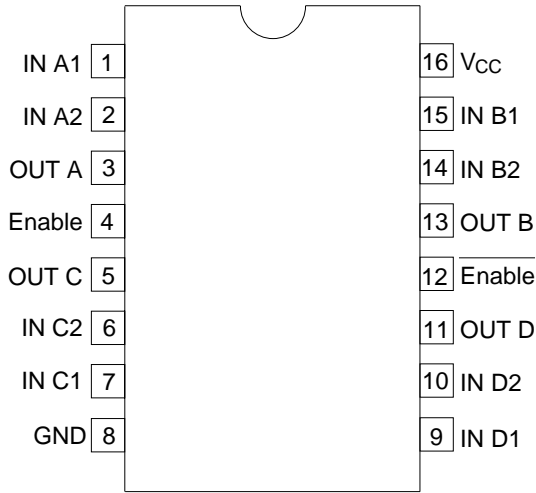

## Function Table

Differential Input	Enable	$\overline{\text{Enable}}$	Outputs
$V_{ID} \geq V_{TH}$ or OPEN	H	X	H
	X	L	
$V_{TL} < V_{ID} < V_{TH}$	H	X	?
	X	L	
$V_{ID} \geq V_{TH}$	H	X	L
	X	L	
X	L	H	Z

H : High level

L : Low level

Z : High impedance

X : Irrelevant

? : Indeterminate

HITACHI

**Absolute Maximum Ratings** (Ta = 25°C)

Item	Symbol	Ratings	Unit
Supply Voltage*2	V <sub>CC</sub>	7	V
Common Mode Input Voltage	V <sub>CM</sub>	±14	V
Differential Input Voltage*3	V <sub>DIFF</sub>	±14	V
Enable Input Voltage	V <sub>IN</sub>	7	V
Output Current	I <sub>O</sub>	±25	mA
Storage Temperature	Tstg	-65 to +150	°C

- Notes: 1. The absolute maximum ratings are values which must not individually be exceeded, and furthermore, no two of which may be realized at the same time.
2. All voltage values except for differential input voltage are with respect to network ground terminal.
3. Differential input voltage is measured at the noninverting input with respect to the corresponding inverting input.

**Recommended Operating Conditions** (Ta = -40°C to +85°C)

Item	Symbol	Min	Typ	Max	Unit
Supply Voltage	V <sub>CC</sub>	4.5	5.0	5.5	V
Common Mode Input Voltage	V <sub>CM</sub>	—	—	±7	V
Differential Input Voltage	V <sub>DIFF</sub>	—	—	±7	V
Output Current	I <sub>O</sub>	—	—	±6	mA
Operating Temperature	Topr	-40	—	85	°C
Enable Input Rise / Fall Time	t <sub>r</sub> , t <sub>f</sub>	—	—	500	ns

- Note: 1. This item guarantees maximum limit when one input switches.  
Waveform: Refer to test circuit of switching characteristics.

## Logic Diagram

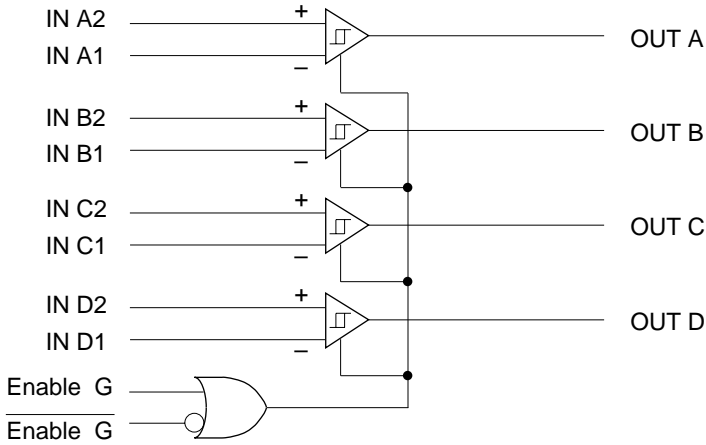

## Electrical Characteristics (Ta = -40°C to +85°C, V<sub>CC</sub> = 5 V ± 10%)

Item	Symbol	Min	Typ	Max	Unit	Conditions
Differential Input	V <sub>TH</sub>	—	—	0.2	V	V <sub>CM</sub> = -7 to 7 V, V <sub>OUT</sub> ≥ 3.8 V
Threshold Voltage	V <sub>TL</sub>	—	—	-0.2	V	V <sub>CM</sub> = -7 to 7 V, V <sub>OUT</sub> ≤ 0.3 V
Input Hysteresis	V <sub>HYST</sub>	—	60	—	mV	V <sub>CM</sub> = 0 V
Enable Input	V <sub>IH</sub>	2.0	—	—	V	
Voltage	V <sub>IL</sub>	—	—	0.8	V	
Output Voltage	V <sub>OH</sub>	3.8	4.2	—	V	V <sub>CC</sub> = 4.5 V, V <sub>DIEF</sub> = 1 V, I <sub>OUT</sub> = -6.0 mA
	V <sub>OL</sub>	—	0.2	0.3	V	V <sub>CC</sub> = 5.5 V, V <sub>DIEF</sub> = -1 V, I <sub>OUT</sub> = 6.0 mA
Output Leak Current <sup>1</sup>	I <sub>OZ</sub>	—	0.5	5.0	μA	Enable = 0.8 V, $\overline{\text{Enable}} = 2.0 \text{ V}$ V <sub>OUT</sub> = V <sub>CC</sub>
		—	-0.5	-5.0	μA	Enable = 0.8 V, $\overline{\text{Enable}} = 2.0 \text{ V}$ V <sub>OUT</sub> = GND
Input Current	I <sub>IN</sub>	—	1.1	1.5	mA	V <sub>IN</sub> = 10 V, Other Input = GND
		-0.1* <sup>1</sup>	—	0.6	mA	V <sub>IN</sub> = 3 V, Other Input = GND
		0	—	-1.1	mA	V <sub>IN</sub> = -3 V, Other Input = GND
		—	-2.0	-2.5	mA	V <sub>IN</sub> = -10 V, Other Input = GND
Enable Input Current	I <sub>I</sub>	—	—	1.0	μA	V <sub>I</sub> = V <sub>CC</sub>
		—	—	-1.0	μA	V <sub>I</sub> = GND
Input Resistance	R <sub>IN</sub>	5.8	6.8	10	kΩ	V <sub>CM</sub> = -7 to 7 V (One Input AC GND)
Supply Current	I <sub>CC</sub>	—	16	23	mA	V <sub>CC</sub> = 5.5 V, V <sub>DIEF</sub> = 1 V

Note: 1. This specification is nonstandard of RS-422A.

**Switching Characteristics** ( $T_a = -40^{\circ}\text{C}$  to  $+85^{\circ}\text{C}$ ,  $V_{CC} = 5\text{ V} \pm 10\%$ )

Item	Symbol	Min	Typ	Max	Unit	Conditions
Propagation Delay Time	$t_{PLH}$	7	16	25	ns	$C_L = 50\text{ pF}$ , $V_{DIEF} = 2.5\text{ V}$ , $V_{CM} = 0\text{ V}$
	$t_{PHL}$	7	16	25	ns	
Output Rise / Fall Time	$t_{RISE}$	—	4	9	ns	$C_L = 50\text{ pF}$ , $V_{DIEF} = 2.5\text{ V}$ , $V_{CM} = 0\text{ V}$
	$t_{FALL}$		4	9	ns	
Output Disable Time	$t_{LZ}$	—	13	22	ns	$C_L = 50\text{ pF}$ , $R_L = 1000\ \Omega$
	$t_{HZ}$		13	22	ns	$V_{DIEF} = 2.5\text{ V}$
Output Enable Time	$t_{ZL}$	—	13	22	ns	$C_L = 50\text{ pF}$ , $R_L = 1000\ \Omega$
	$t_{ZH}$		13	22	ns	$V_{DIEF} = 2.5\text{ V}$

## 1. $t_{PLH}$ , $t_{PHL}$ , $t_{RISE}$ , $t_{FALL}$

### Test Circuit

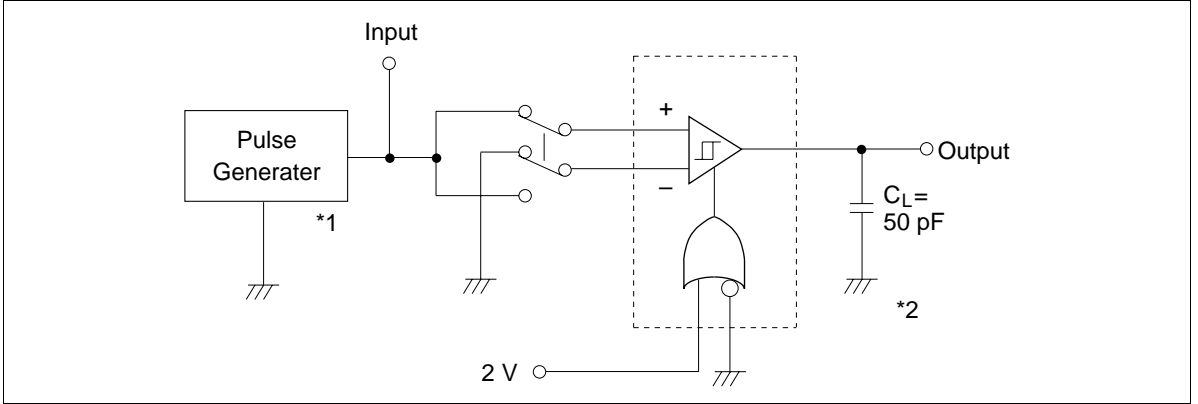

### Wave forms

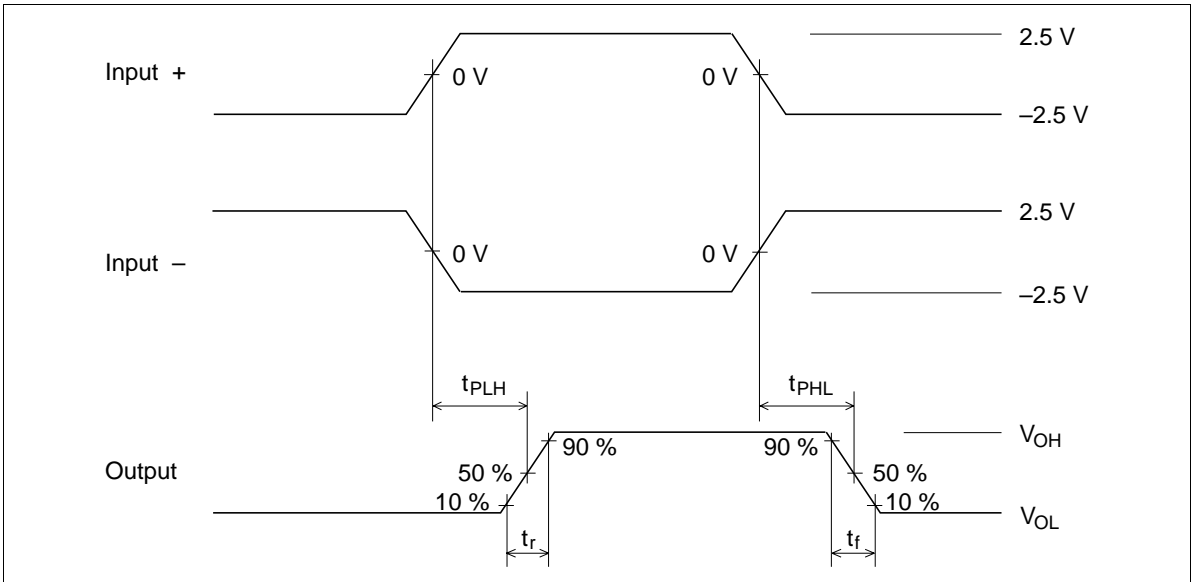

2.  $t_{HZ}$ ,  $t_{ZH}$

Test Circuit

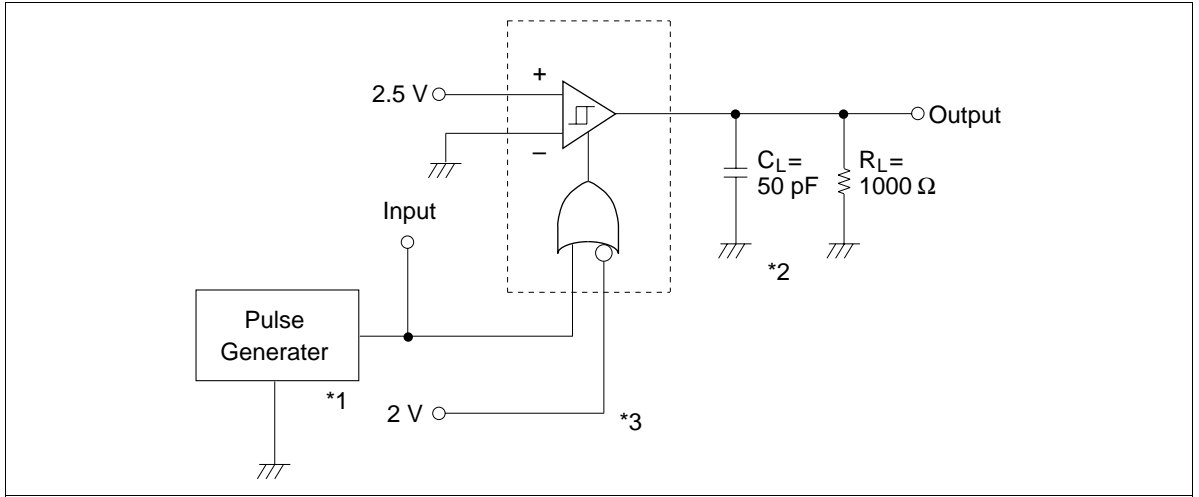

Wave forms

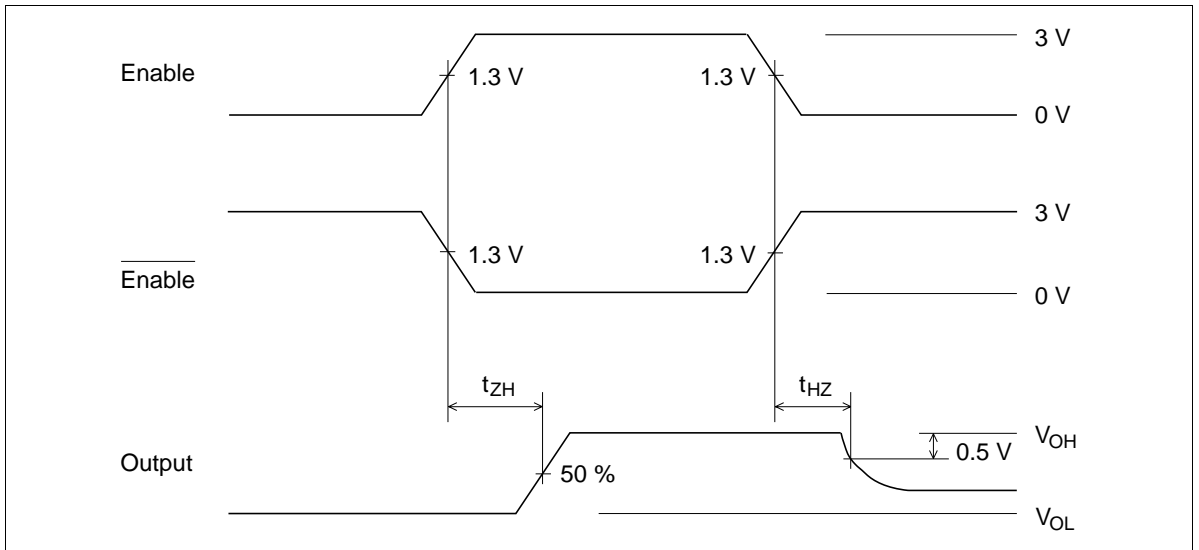

## 3. $t_{LZ}$ , $t_{ZL}$

### Test circuit

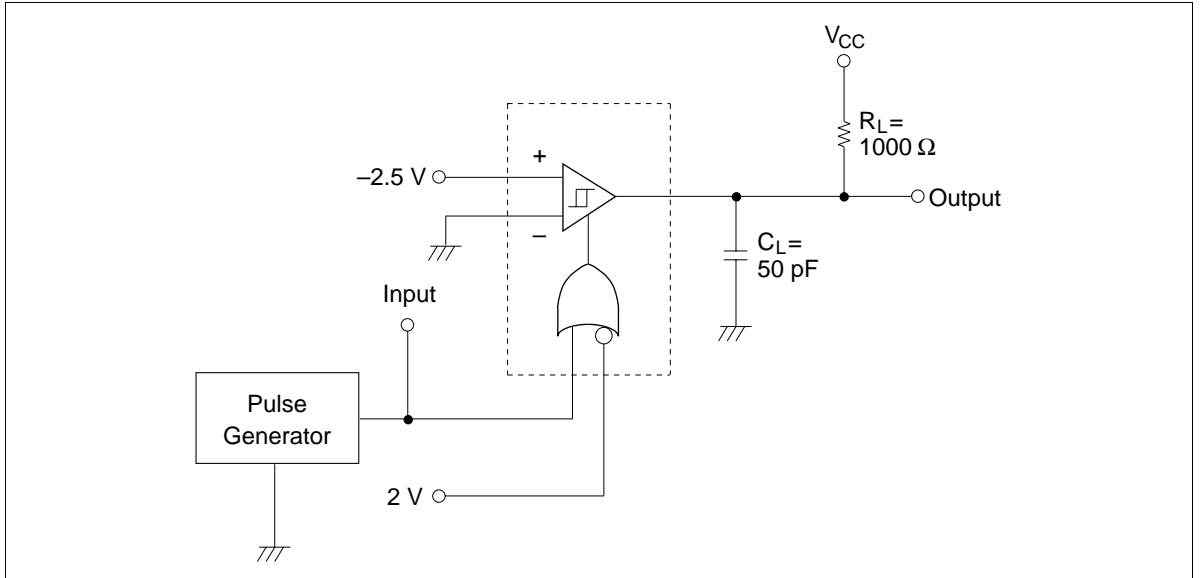

### Wave forms

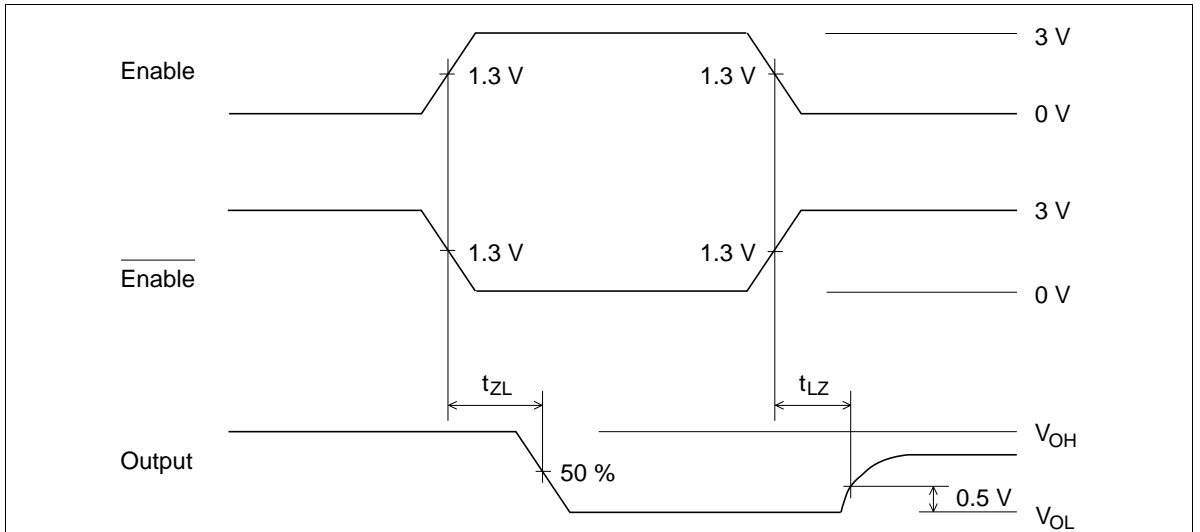

- Notes:
1. The pulse generator has the following characteristics:  
 $PRR = 1 \text{ MHz}$ , 50 % duty cycle,  $t_r \leq 6 \text{ ns}$ ,  $t_f \leq 6 \text{ ns}$ ,  $Z_{out} = 50 \Omega$
  2.  $C_L$  includes probe and jig capacitance.
  3. To test  $\overline{\text{Enable}}$  input, ground Enable input and apply an inverted input waveform.

## HD26C32A Line Receiver Applications

The HD26C32A is a line receiver that meets the EIA RS-422A and RS-423A conditions. It has a high in-phase input voltage range, both positive and negative, enabling highly reliable transmission to be performed even in noisy environments.

Its main features are listed below.

- Operates on a single 5 V power supply.
- $\pm 0.2$  V input sensitivity in in-phase input voltage  $\pm 7$  V range
- Three-state output
- On-chip input fail-safe circuit
- On-chip power up/down protection circuit

As shown by the logic diagram, the enable function is common to all four drivers, and either active-high or active-low input can be selected.

When exchange is carried out using a party line system, it is better to keep the receiver input bias current constituting the driver load small, as this allows more receivers to be connected.

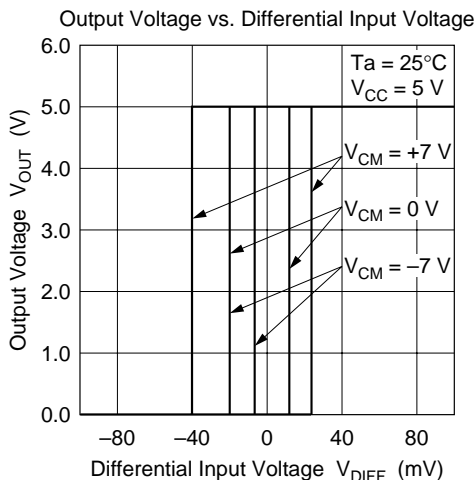

Figure 1 Differential Input Voltage vs. Output Voltage Characteristics

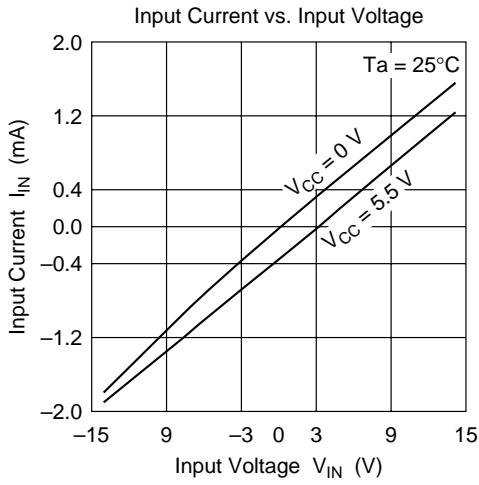

Figure 2 Input Voltage vs. Input Current Characteristics

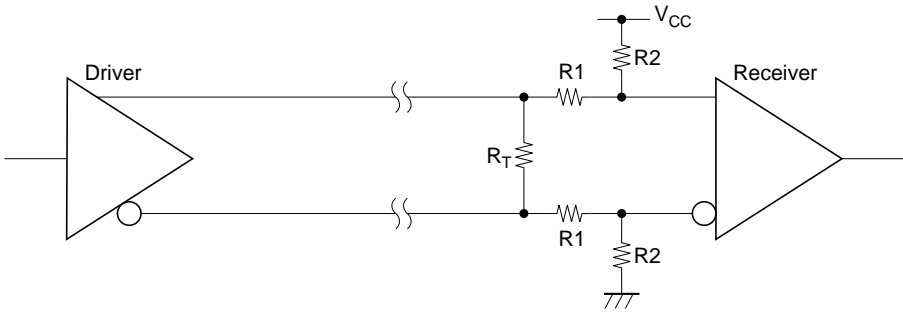

Figure 3 Method of Enhancing Fail-Safe Function

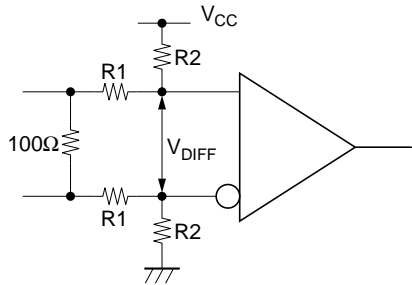
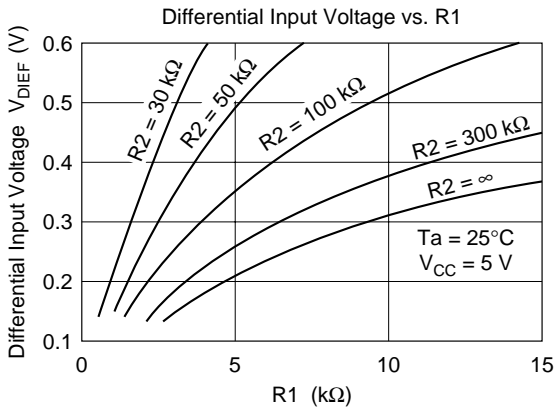

Figure 4  $R_1, R_2$  vs. Differential Input Voltage

1. Unidirectional Transmission (1 : 1 Configuration)

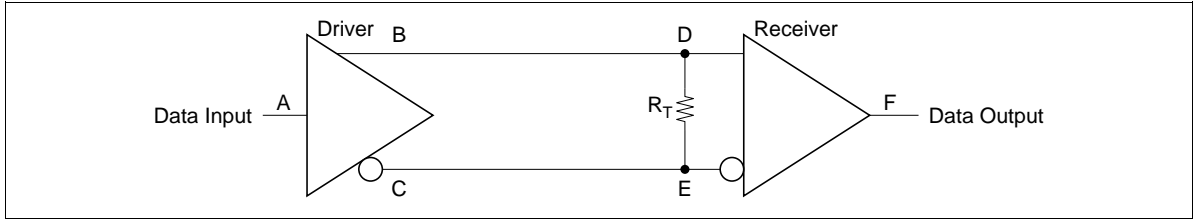

Figure 5 1 : 1 Unidirectional Transmission

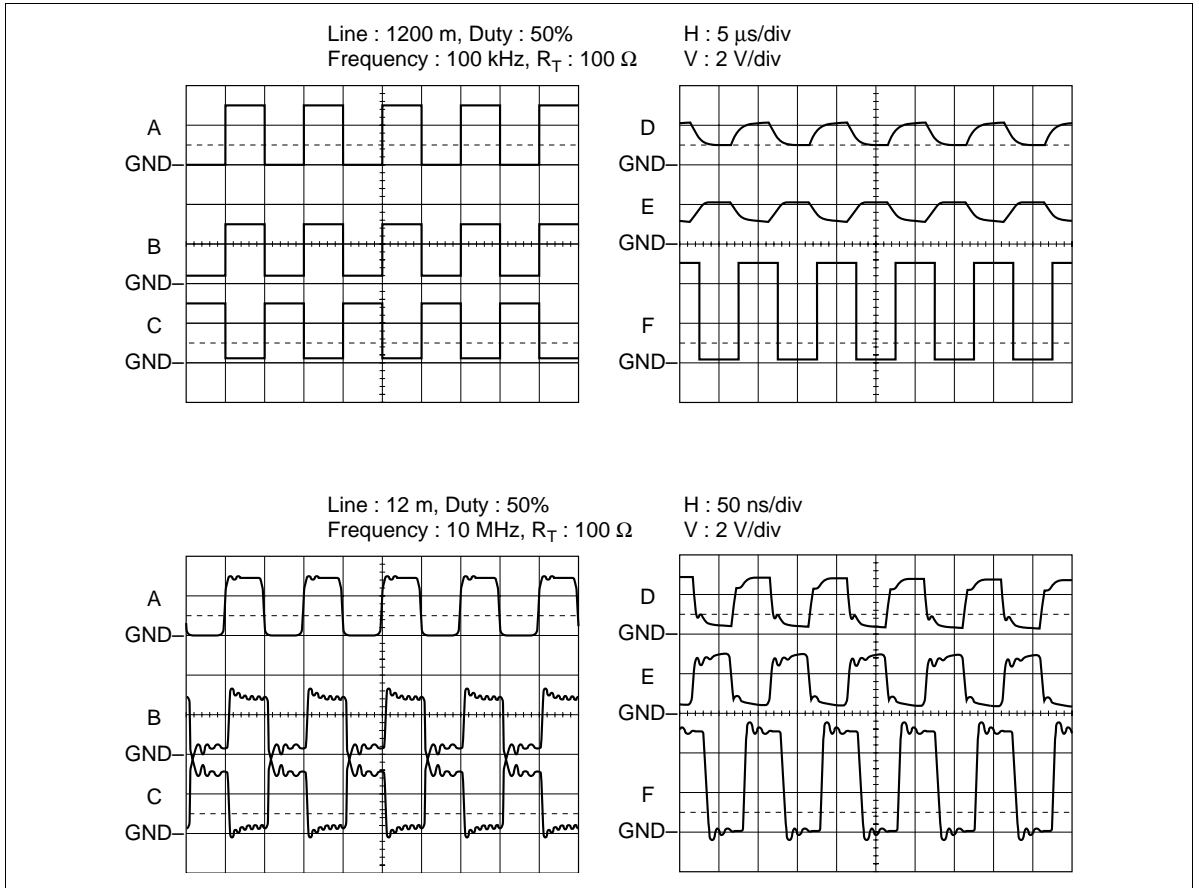
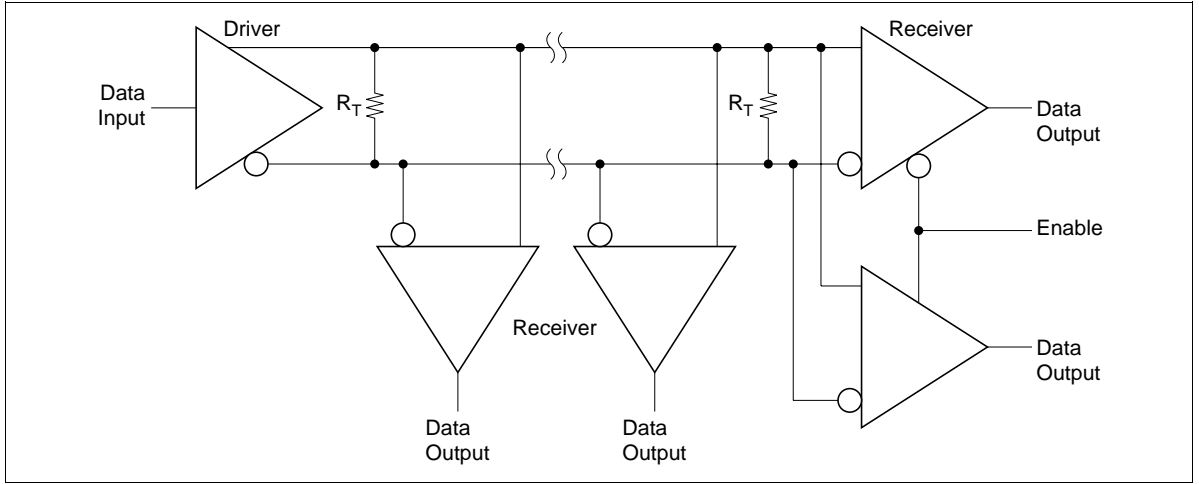

Figure 6 Sample Transmission Waveforms

## 2. Unidirectional Transmission (1 : n Configuration)

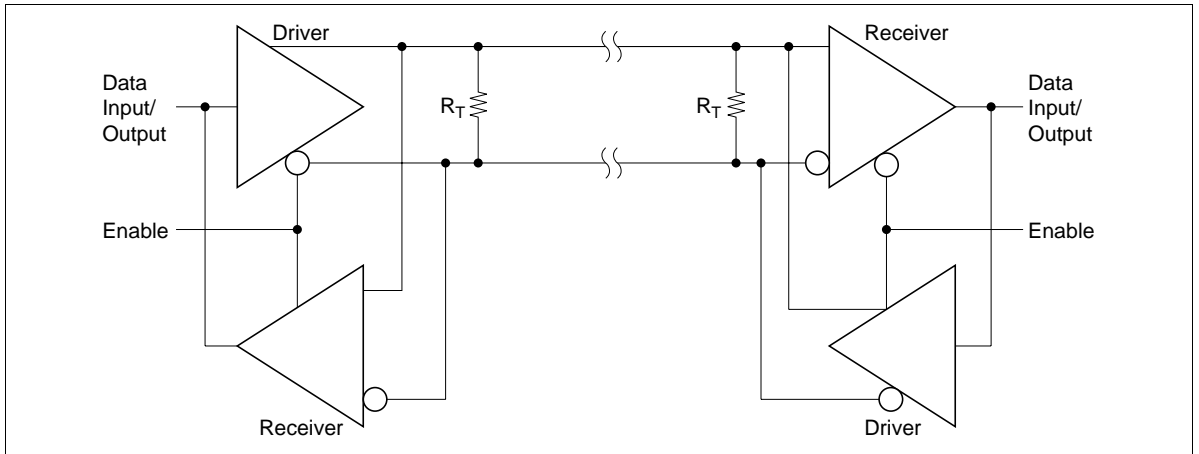

**Figure 7 1:n Unidirectional Transmission**

With this connection method, n receivers are connected for one driver. In the RS-422A standard, ten receivers can be connected simultaneously for one driver.

Conversely, it is also possible to connect one receiver for n drivers.

## 3. Bidirectional Transmission



**Figure 8 Bidirectional Transmission**

When bidirectional data exchange is performed using a combination of the HD26C31 and HD26C32A, since either high or low output control is possible, using complementary enable inputs for the driver and receiver makes it easy to configure the kind of combination illustrated in figure 8.

Extending this combination makes it possible to exchange n-bit data simultaneously, and handle a party line system.

Package Dimensions

Unit: mm

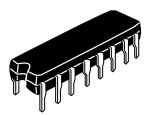
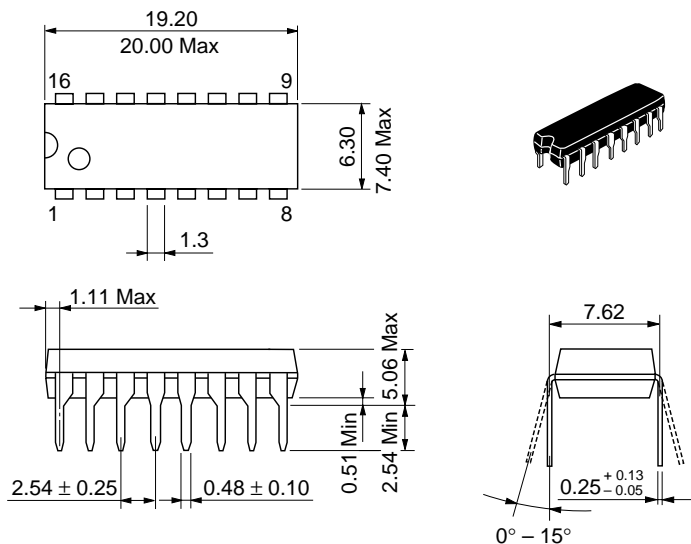

Hitachi Code	DP-16
JEDEC	Conforms
EIAJ	Conforms
Mass (reference value)	1.07 g

Unit: mm

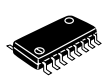
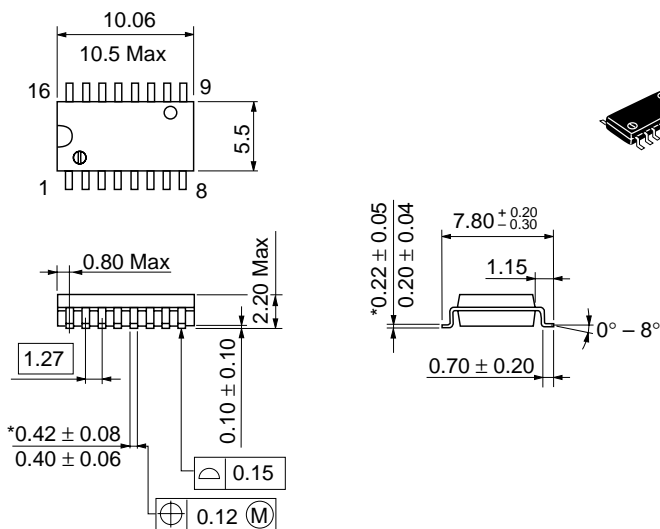

Hitachi Code	FP-16DA
JEDEC	—
EIAJ	Conforms
Mass (reference value)	0.24 g

\*Dimension including the plating thickness  
Base material dimension

## Cautions

1. Hitachi neither warrants nor grants licenses of any rights of Hitachi's or any third party's patent, copyright, trademark, or other intellectual property rights for information contained in this document. Hitachi bears no responsibility for problems that may arise with third party's rights, including intellectual property rights, in connection with use of the information contained in this document.
2. Products and product specifications may be subject to change without notice. Confirm that you have received the latest product standards or specifications before final design, purchase or use.
3. Hitachi makes every attempt to ensure that its products are of high quality and reliability. However, contact Hitachi's sales office before using the product in an application that demands especially high quality and reliability or where its failure or malfunction may directly threaten human life or cause risk of bodily injury, such as aerospace, aeronautics, nuclear power, combustion control, transportation, traffic, safety equipment or medical equipment for life support.
4. Design your application so that the product is used within the ranges guaranteed by Hitachi particularly for maximum rating, operating supply voltage range, heat radiation characteristics, installation conditions and other characteristics. Hitachi bears no responsibility for failure or damage when used beyond the guaranteed ranges. Even within the guaranteed ranges, consider normally foreseeable failure rates or failure modes in semiconductor devices and employ systemic measures such as fail-safes, so that the equipment incorporating Hitachi product does not cause bodily injury, fire or other consequential damage due to operation of the Hitachi product.
5. This product is not designed to be radiation resistant.
6. No one is permitted to reproduce or duplicate, in any form, the whole or part of this document without written approval from Hitachi.
7. Contact Hitachi's sales office for any questions regarding this document or Hitachi semiconductor products.

# HITACHI

## Hitachi, Ltd.

Semiconductor & Integrated Circuits.  
Nippon Bldg., 2-6-2, Ohte-machi, Chiyoda-ku, Tokyo 100-0004, Japan  
Tel: Tokyo (03) 3270-2111 Fax: (03) 3270-5109

URL      NorthAmerica      : <http://semiconductor.hitachi.com/>  
             Europe                : <http://www.hitachi-eu.com/hel/ecg>  
             Asia                        : <http://sicapac.hitachi-asia.com>  
             Japan                        : <http://www.hitachi.co.jp/Sicd/indx.htm>

## For further information write to:

Hitachi Semiconductor  
(America) Inc.  
179 East Tasman Drive,  
San Jose, CA 95134  
Tel: <1> (408) 433-1990  
Fax: <1> (408) 433-0223

Hitachi Europe GmbH  
Electronic Components Group  
Dornacher StraÙe 3  
D-85622 Feldkirchen, Munich  
Germany  
Tel: <49> (89) 9 9180-0  
Fax: <49> (89) 9 29 30 00

Hitachi Europe Ltd.  
Electronic Components Group.  
Whitebrook Park  
Lower Cookham Road  
Maidenhead  
Berkshire SL6 8YA, United Kingdom  
Tel: <44> (1628) 585000  
Fax: <44> (1628) 585160

Hitachi Asia Ltd.  
Hitachi Tower  
16 Collyer Quay #20-00,  
Singapore 049318  
Tel: <65>-538-6533/538-8577  
Fax: <65>-538-6933/538-3877  
URL: <http://www.hitachi.com.sg>

Hitachi Asia Ltd.  
(Taipei Branch Office)  
4/F, No. 167, Tun Hwa North Road,  
Hung-Kuo Building,  
Taipei (105), Taiwan  
Tel: <886>-(2)-2718-3666  
Fax: <886>-(2)-2718-8180  
Telex: 23222 HAS-TP  
URL: <http://www.hitachi.com.tw>

Hitachi Asia (Hong Kong) Ltd.  
Group III (Electronic Components)  
7/F., North Tower,  
World Finance Centre,  
Harbour City, Canton Road  
Tsim Sha Tsui, Kowloon,  
Hong Kong  
Tel: <852>-(2)-735-9218  
Fax: <852>-(2)-730-0281  
URL: <http://www.hitachi.com.hk>

Copyright © Hitachi, Ltd., 2000. All rights reserved. Printed in Japan.  
Colophon 2.0

## HITACHI