



ON Semiconductor®

<http://onsemi.com>

LC898214XC

CMOS LSI

AF Controller

Overview

This LSI is AF control LSI. It consists of 1 system of feedback circuit for AF control.

Features

- Built-in equalizer circuit using digital operation
 - AF control equalize circuit
 - Any coefficient can be specified by I²C I/F
- I²C Interface
- Built-in A/D converter
 - Maximum 10-bit
 - Input 2 channel
- Built-in D/A converter
 - 8-bit
 - Output 2-channel (Hall offset, Constant current Bias)
- Built-in Hall Sensor
 - Si Hall sensor
- Built-in EEPROM
 - 128 byte (8 byte/page)
- Built-in VGA
 - Hall Amp
- Built-in OSC
 - 48MHz
- Built-in Constant Current Driver
- Package
 - WL-CSP 8-pin
 - Lead-free, halogen-free
- Supply voltage
 - V_{DD} (2.6V to 3.6V)

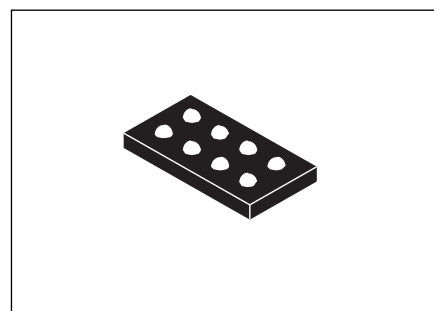

WLCSP8, 1.15x2.37, 0.5P

* I²C Bus is a trademark of Philips Corporation.

ORDERING INFORMATION

See detailed ordering and shipping information on page 8 of this data sheet.

Pin Description

TYPE					
I	INPUT	P	Power supply, GND	NC	NOT CONNECT
O	OUTPUT				
B	BIDIRECTION				

■ I²C interface

I2CCK	B	I ² C Clock pin
I2CDT	B	I ² C Data pin

■ Hall interface

HALL	O	Hall amp output
------	---	-----------------

■ Driver interface

OUT1	O	Actuator output pin
OUT2	O	Actuator output pin

■ Power supply pin

VDD	P	Power supply
VSS	P	GND

■ Test pin

TEST	O	Test pin
------	---	----------

*Process when pins are not used

PIN TYPE “O” – Ensure that it is set to OPEN.

PIN TYPE “I” – OPEN is inhibited. Ensure that it is connected to the VDD or VSS even when it is unused.

(Please contact ON Semiconductor for more information about selection of VDD or VSS.)

PIN TYPE “B” – If you are unsure about processing method on the pin description of pin layout table, please contact us.

Note that incorrect processing of unused pins may result in defects.

LC898214XC

Pin Layout

Circuit Name	Number of Pins	Circuit Name	Number of Pins
Analog	4	Driver	2
Logic	2		

Backside pin layout diagram (Top View from the mold side)

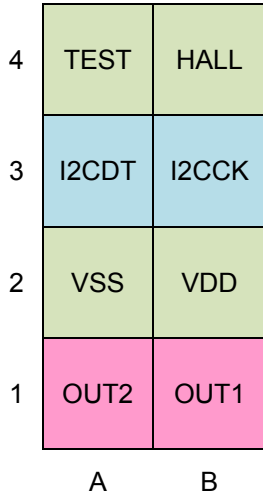

Block Diagram

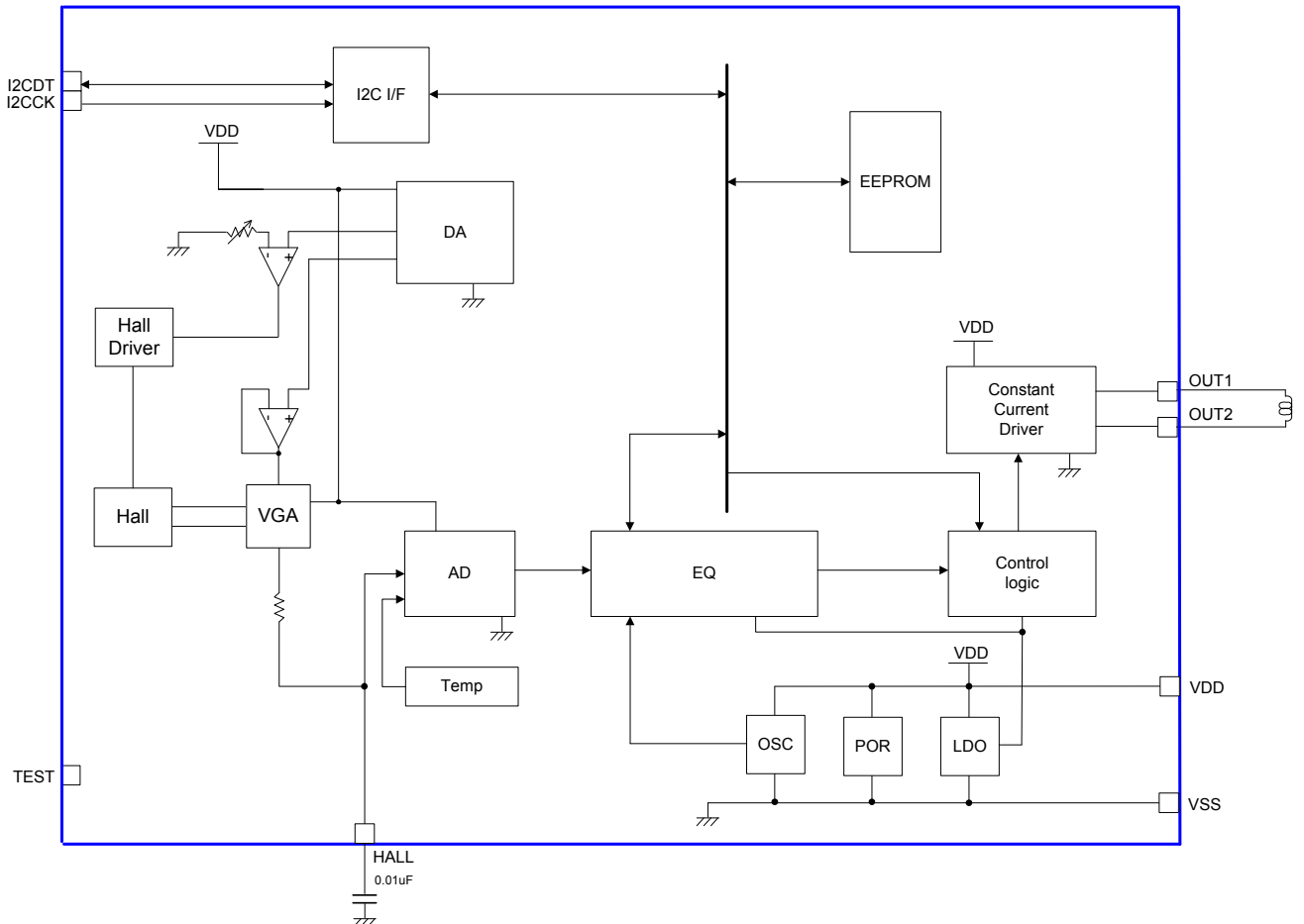

LC898214XC

Electrical Characteristics

1) Absolute maximum rating at $V_{SS} = 0V$

Item	Symbol	Condition	Rating	Unit
Supply voltage	V_{DD33} max	$T_a \leq 25^\circ C$	-0.3 to 4.6	V
Input/output voltage	V_{I33}, V_{O33}	$T_a \leq 25^\circ C$	-0.3 to $V_{DD33}+0.3$	V
Storage ambient temperature	Tstg		-55 to 125	$^\circ C$
Operating ambient temperature	Topr		-30 to 70	$^\circ C$
Peak output current	lopeak	OUT1,OUT2 $t \leq 10$ msec, On-duty $\leq 20\%$	180	mA
Continuous output current	lomax	OUT1,OUT2	120	mA

Stresses exceeding those listed in the Maximum Ratings table may damage the device. If any of these limits are exceeded, device functionality should not be assumed, damage may occur and reliability may be affected.

2) Acceptable operation range at $T_a = -30$ to $70^\circ C$, $V_{SS} = 0V$ 3V power supply (DVDD)

Item	Symbol	Min	Std	Max	Unit
Supply voltage	V_{DD33}	2.6	2.8	3.6	V
Input voltage range	V_{IN}	0	-	V_{DD33}	V

Functional operation above the stresses listed in the Recommended Operating Ranges is not implied. Extended exposure to stresses beyond the Recommended Operating Ranges limits may affect device reliability.

3) DC characteristics : Input/output level at $V_{SS} = 0V$, $V_{DD} = 2.6V$ to $3.6V$, $T_a = -30$ to $70^\circ C$

Item	Symbol	Condition	Min	Std	Max	Unit	Applicable pins
High-level input voltage	V_{IH}	CMOS compliant Schmidt	1.4			V	I2CCK, I2CDT,
Low-level input voltage	V_{IL}						
Low-level output voltage	V_{OL}	IOL= 2mA			0.4	V	I2CDT

Product parametric performance is indicated in the Electrical Characteristics for the listed test conditions, unless otherwise noted. Product performance may not be indicated by the Electrical Characteristics if operated under different conditions.

4) Driver output (OUT1, OUT2) at $V_{SS} = 0V$, $V_{DD} = 2.8V$, $T_a = 25^\circ C$

Item	Symbol	Condition	Min	Std	Max	Unit	Applicable pins
Output ON resistance	Ronu	Io=120mA Pch		2.8		Ω	OUT1, OUT2
	Rond	Io=120mA Nch		2.0		Ω	
Output leak current	Ioleak			1		μA	
Diode forward voltage	VD	ID=-120mA		0.9		V	

5) Non-volatile Memory Characteristics

Item	Symbol	Condition	Min	Std	Max	Unit	Applicable pins
Endurance	EN				100	Cycles	E2PROM
Data retention	RT		10			Years	

Hall element position

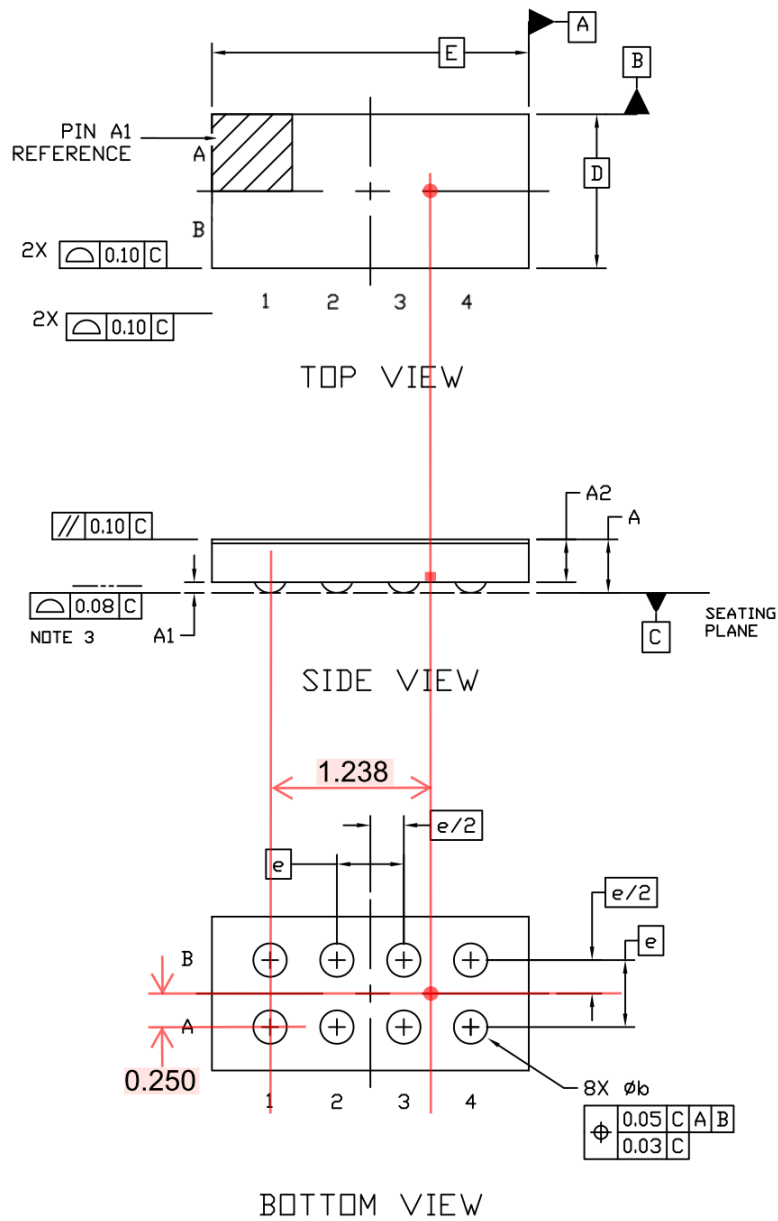

Figure 1 : Hall element position

Please refer to package diagram for each dimension.

AC Characteristics

VDD supply timing

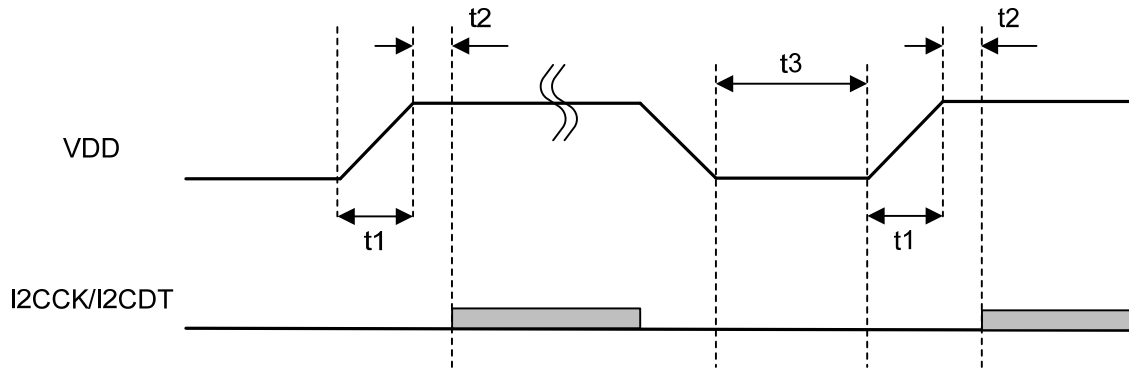

Figure 2 : VDD supply timing

It is available to use I²C 2ms later for Power On Reset of VDD.

Item	Symbol	Min	Typ	Max	Unit
VDD turn on time	t1			3	ms
I ² C start time from VDD on	t2	2			ms
VDD off time	t3	10			ms

AC specification

Figure 2 shows interface timing definition and Table 1 shows electric characteristics.

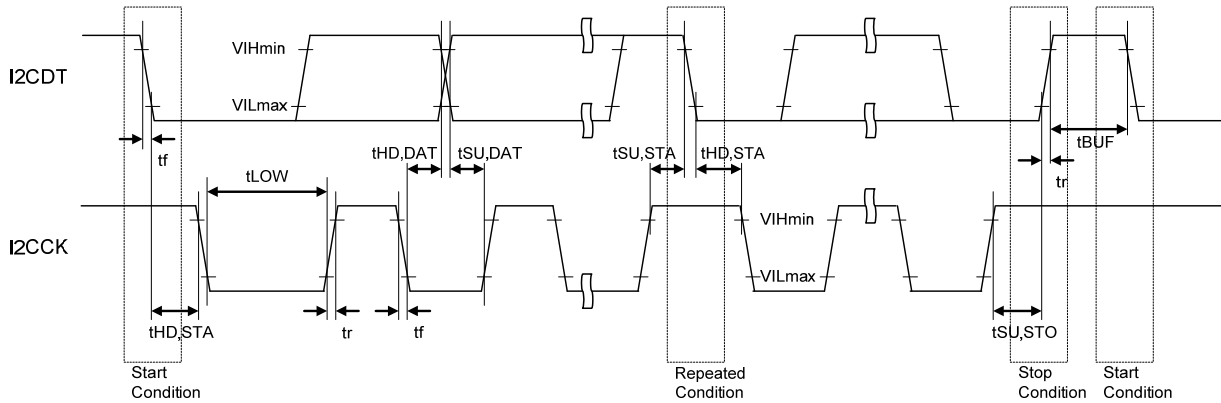

Figure 3 : I²C interface timing definition

Table 1 : Electric characteristics for I²C interface (AC characteristics)

Item	Symbol	Pin name	Min	Typ	Max	Unit
I2CCK clock frequency	Fi2cck	I2CCK			400	kHz
START condition hold time	tHD,STA	I2CCK I2CDT	0.6			μs
I2CCK clock Low period	tLOW	I2CCK	1.3			μs
I2CCK clock High period	tHIGH	I2CCK	0.6			μs
Setup time for repetition START condition	tSU,STA	I2CCK I2CDT	0.6			μs
Data hold time	tHD,DAT	I2CCK I2CDT	0 (*3)		0.9	μs
Data setup time	tSU,DAT	I2CCK I2CDT	100			ns
I2CDT, I2CCK rising time	tr	I2CCK I2CDT			300	ns
I2CDT, I2CCK falling time	tf	I2CCK I2CDT			300	ns
STOP condition setup time	tSU,STO	I2CCK I2CDT	0.6			μs
Bus free time between STOP and START	tBU	I2CCK I2CDT	1.3			μs

*3 : Although the I²C specification defines a condition that 300 ns of hold time is required internally, LC898214XC is designed for a condition with typ. 20 ns of hold time. If I2CDT signal is unstable around falling point of I2CCK signal, please implement an appropriate treatment on board, such as inserting a resistor.

LC898214XC

Package Dimensions

unit : mm

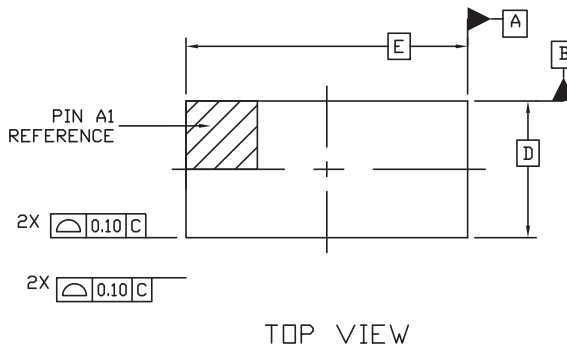

NOTES:

1. DIMENSIONING AND TOLERANCING PER ASME Y14.5M, 1994.
2. CONTROLLING DIMENSION: MILLIMETERS
3. COPLANARITY APPLIES TO THE SPHERICAL CROWNS OF THE SOLDER BALLS.

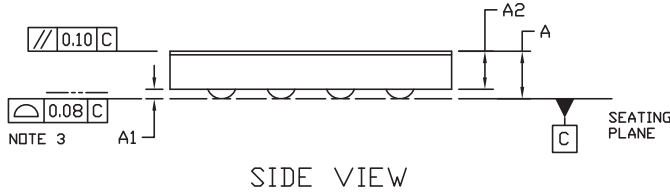

DIM	MILLIMETERS	
	MIN.	MAX.
A	0.35	0.45
A1	0.045	0.115
b	0.20	0.30
D	1.15 BSC	
E	2.37 BSC	
e	0.50 BSC	

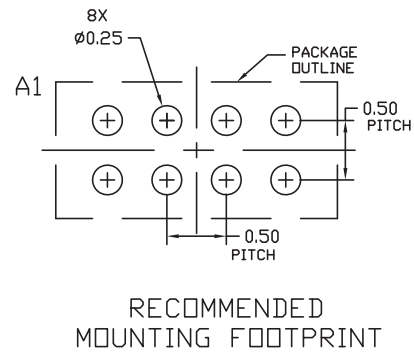
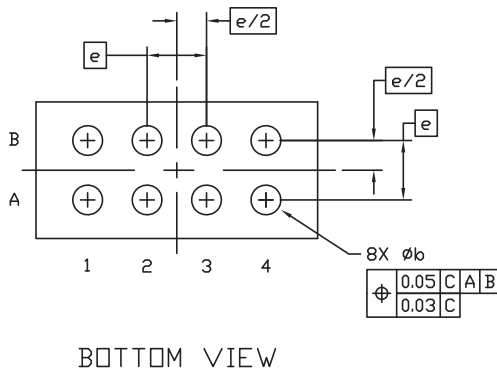

ORDERING INFORMATION

Device	Package	Shipping (Qty / Packing)
LC898214XC-MH	WLCSP8, 1.15x2.37, 0.5P (Pb-Free / Halogen Free)	4000 / Tape & Reel

ON Semiconductor and the ON logo are registered trademarks of Semiconductor Components Industries, LLC (SCILLC) or its subsidiaries in the United States and/or other countries. SCILLC owns the rights to a number of patents, trademarks, copyrights, trade secrets, and other intellectual property. A listing of SCILLC's product/patent coverage may be accessed at www.onsemi.com/site/pdf/Patent-Marking.pdf. SCILLC reserves the right to make changes without further notice to any products herein. SCILLC makes no warranty, representation or guarantee regarding the suitability of its products for any particular purpose, nor does SCILLC assume any liability arising out of the application or use of any product or circuit, and specifically disclaims any and all liability, including without limitation special, consequential or incidental damages. "Typical" parameters which may be provided in SCILLC data sheets and/or specifications can and do vary in different applications and actual performance may vary over time. All operating parameters, including "Typicals" must be validated for each customer application by customer's technical experts. SCILLC does not convey any license under its patent rights nor the rights of others. SCILLC products are not designed, intended, or authorized for use as components in systems intended for surgical implant into the body, or other applications intended to support or sustain life, or for any other application in which the failure of the SCILLC product could create a situation where personal injury or death may occur. Should Buyer purchase or use SCILLC products for any such unintended or unauthorized application, Buyer shall indemnify and hold SCILLC and its officers, employees, subsidiaries, affiliates, and distributors harmless against all claims, costs, damages, and expenses, and reasonable attorney fees arising out of, directly or indirectly, any claim of personal injury or death associated with such unintended or unauthorized use, even if such claim alleges that SCILLC was negligent regarding the design or manufacture of the part. SCILLC is an Equal Opportunity/Affirmative Action Employer. This literature is subject to all applicable copyright laws and is not for resale in any manner.