

## Hybrid IC Isolation Amplifiers 20 Series

### ISOLATION AMPLIFIER

(high-accuracy, input isolation)

#### Functions & Features

- Being used for printed wiring board installation
- Up to 2500 V isolation between input to output or power input
- High-linearity
- Small installation area in printed wiring board
- Gain adjustable range,  $\times 1$  to  $\times 10$
- Power 15 V DC

#### Typical Applications

- Isolating the field and input circuit of microprocessor to reduce noise from field
- Available for manufacturers of small-lot products to omit the development of isolation circuit

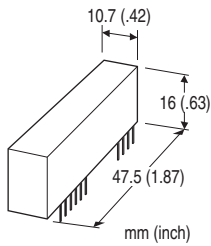

### MODEL: 20VS5-204-U

#### ORDERING INFORMATION

- Code number: 20VS5-204-U

INPUT RANGE -10 - +10 V DC

OUTPUT RANGE -10 - +10 V DC

#### POWER INPUT

**DC Power**

U: 15 V DC

#### GENERAL SPECIFICATIONS

**Construction:** Hybrid IC

**Housing material:** Flame-resistant resin (black)

**Isolation:** Input to output or power

#### INPUT SPECIFICATIONS

■ **DC Voltage**

**Input :** -10 - +10 V DC

**Input resistance:**  $\geq 1 \text{ M}\Omega$  (10 k $\Omega$  in power failure)

**Overload input voltage:**  $\pm 30 \text{ V DC}$  continuous

**Input offset voltage:**  $\pm 15 \text{ mV}$

**Input bias current:** 0.5 nA TYP. (@25°C)

#### OUTPUT SPECIFICATIONS

■ **DC Voltage:** -10 - +10 V DC

**Load resistance:**  $\geq 5 \text{ k}\Omega$

**Output impedance:**  $\leq 1 \Omega$

#### REFERENCE VOLTAGE SOURCE

**Output voltage:**  $\pm 15 \text{ V DC TYP.}$

**Load current:**  $\leq 2 \text{ mA}$

#### INSTALLATION

##### Power input

- **DC:** Operational voltage range: Rating  $\pm 10 \%$ , ripple 2 %p-p max.; approx. 7 mA with no load

**Operating temperature:** -10 to +70°C (14 to 158°F)

**Operating humidity:** 30 to 90 %RH (non-condensing)

**Mounting:** Soldering to the printed wiring board

**Weight:** 10g (0.35 oz)

#### PERFORMANCE in percentage of span

Unless otherwise specified,  $G = 1$ .

**Linearity:**  $\pm 0.005 \%$  TYP. ( $\pm 0.025 \%$  max.)

**Temp. coefficient:**

Offset drift 20 ppm/°C

Span drift 40 ppm/°C

**Frequency characteristics:** Approx. 3 kHz, -3 dB

**Response time:**  $\leq 150 \mu\text{sec.}$  (0 - 90 %)

**Conversion gain:**  $\times 0.98 \pm 5 \%$

**Gain adjustable range:**  $\times 1$  to  $\times 10$

**Line voltage effect:**  $\pm 0.05 \%$  over voltage range

**Insulation resistance:**  $\geq 100 \text{ M}\Omega$  with 500 V DC

**Dielectric strength:** 2500 V AC @1 minute (input or reference voltage source to output or power)

**CMRR:**  $\geq 100 \text{ dB}$  (500 V AC 50/60 Hz)

## EXTERNAL DIMENSIONS & TERMINAL ASSIGNMENTS unit: mm (inch)

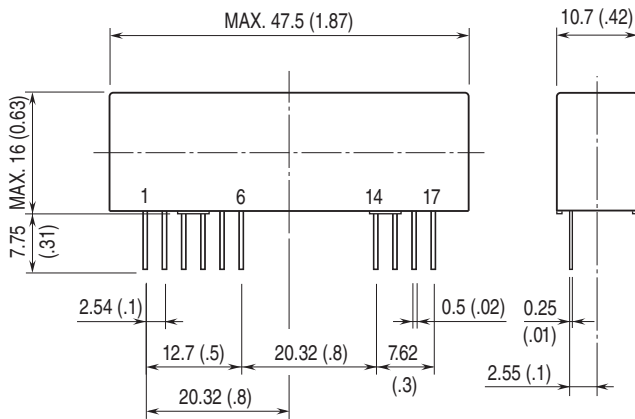

### PIN ASSIGNMENT

1	FEEDBACK
2	INVERTING INPUT
3	NON-INVERTING INPUT
4	COM (-)
5	REFERENCE VOLTAGE SOURCE (+)
6	REFERENCE VOLTAGE SOURCE (-)
14	POWER SUPPLY (+)
15	POWER SUPPLY (-)
16	OUTPUT (-)
17	OUTPUT (+)

## SCHEMATIC CIRCUITRY & CONNECTION DIAGRAM

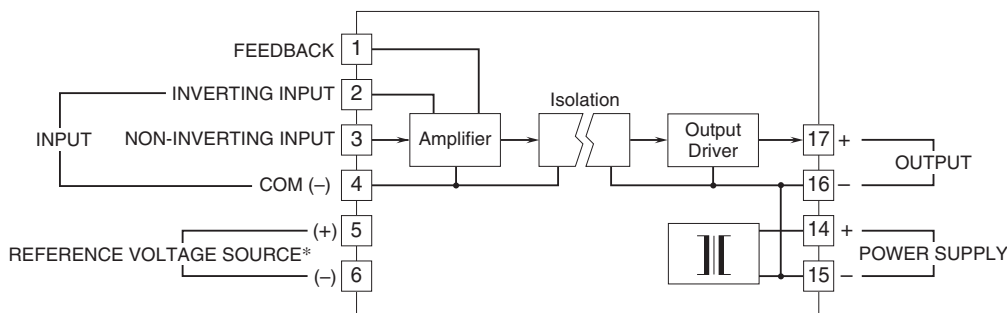

\*To be used in the printed wiring board on which the unit is mounted.  
Note. The reference voltage source is common to the COM (-), terminal 4.

## APPLICATION EXAMPLE

The series resistance of the amplifier,  $R_1 + R_2$  must be between 10 k $\Omega$  and 200 k $\Omega$ .

■ Non-inverting amplifier circuit: Basic example of  $G = 0.98$

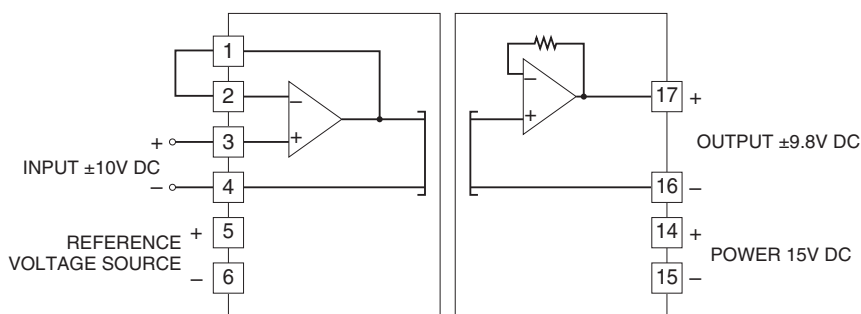

■ Inverting amplifier circuit: Basic example of  $G = -1$  (output inverted to the input) ( $R_1 \approx R_2$ )

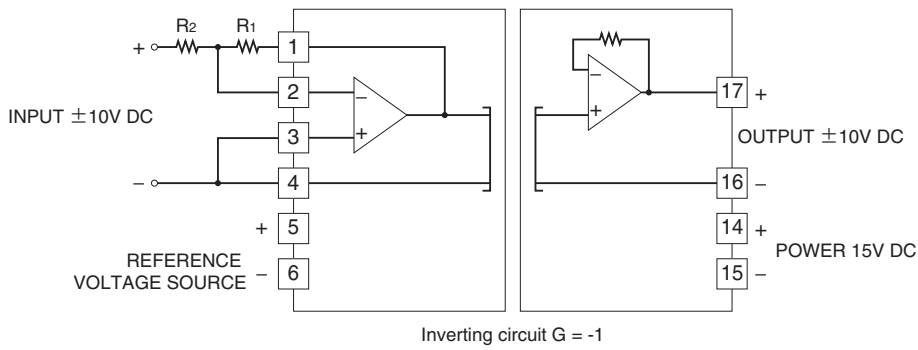

■ Non-inverting amplifier circuit: Example of  $G = 1 + R_1 / R_2$

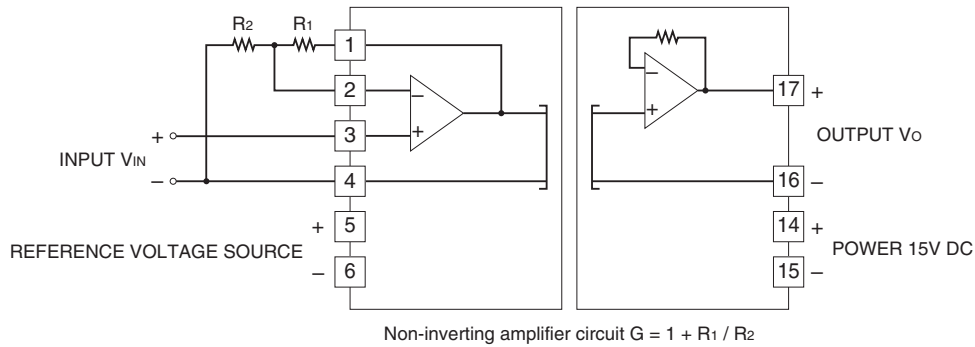

■ Inverting amplifier circuit: Example of  $G = -R_1 / R_2$  (output inverted to the input)

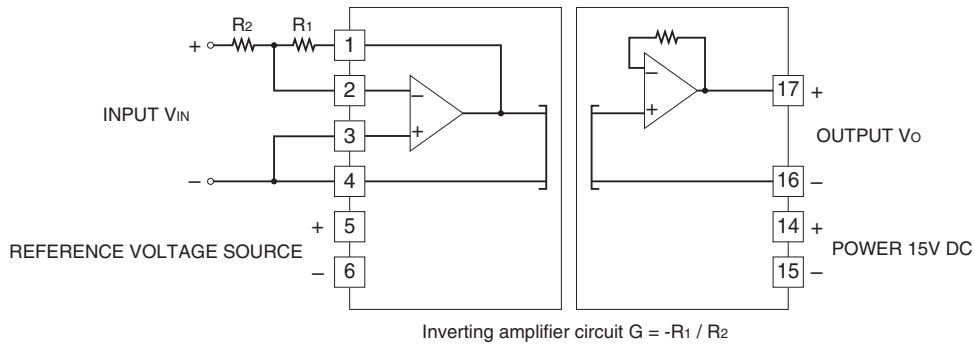

■ Non-inverting amplifier's circuit with external adjustments: Example of  $G = 2$

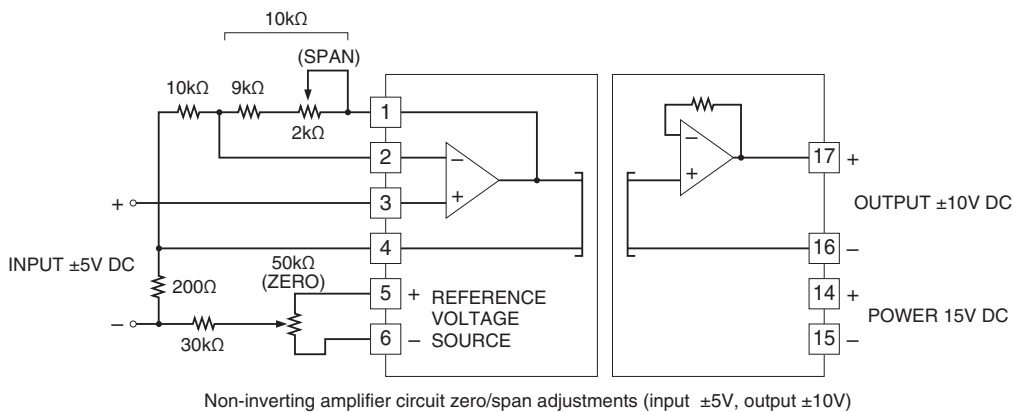

■ Inverting amplifier's circuit with external adjustments: Example of  $G = -1$  (output inverted to the input)

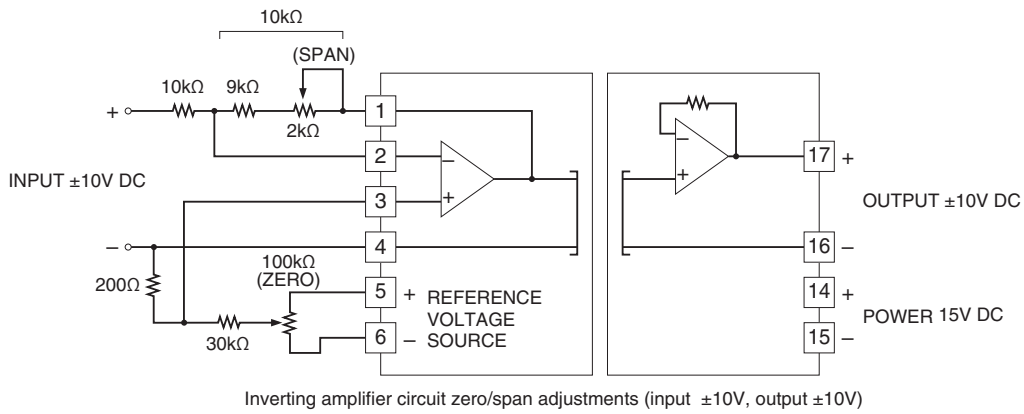

Specifications are subject to change without notice.