

Pb Free Plating Product

## BR75N75



75V,80A Heatsink Planar N-Channel Power MOSFETs

## FEATURES

- \*  $R_{DS(ON)} = 9.5m\Omega @ V_{GS} = 10V$  (Typical)
- \* Ultra low gate charge ( typical 117 nC )
- \* Fast switching capability
- \* Low reverse transfer Capacitance ( $C_{RSS} =$  typical 240 pF )
- \* Avalanche energy Specified
- \* Improved dv/dt capability, high ruggedness

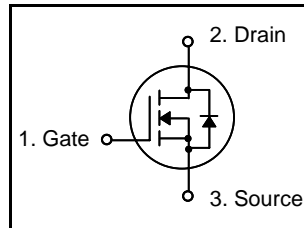
 $BV_{DSS} = 75V$  $R_{DS(ON)} = 0.011 \text{ ohm}$  $I_D = 80A$ 

## General Description

This N-channel enhancement mode field-effect power transistor using THINKI Semiconductor advanced planar stripe, DMOS technology intended for off-line switch mode power supply.

Also, especially designed to minimize  $r_{ds(on)}$  and high rugged avalanche characteristics. The TO-220M-SQ pkg is well suited for adaptor power units, amplifiers, inverters and SMPS application.

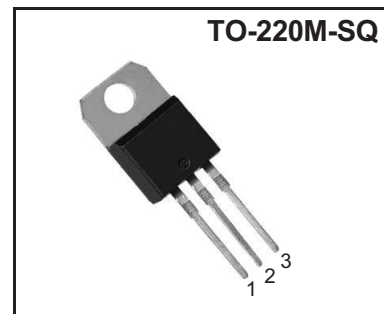

■ ABSOLUTE MAXIMUM RATINGS

PARAMETER	SYMBOL	RATINGS	UNIT
Drain-Source Voltage	$V_{DSS}$	75	V
Gate-Source Voltage	$V_{GSS}$	$\pm 20$	V
Continuous Drain Current	$I_D$	80	A
Pulsed Drain Current (Note 2)	$I_{DM}$	320	A
Single Pulsed Avalanche Energy (Note 3)	$E_{AS}$	700	mJ
Peak Diode Recovery dv/dt (Note 4)	dv/dt	12	V/ns
Power Dissipation	$P_D$	TO-220/TO-263	300
		TO-220F	45
Junction Temperature	$T_J$	+175	$^{\circ}C$
Storage Temperature	$T_{STG}$	-55 ~ +175	$^{\circ}C$

Note: 1. Absolute maximum ratings are those values beyond which the device could be permanently damaged.

Absolute maximum ratings are stress ratings only and functional device operation is not implied.

2. Pulse width limited by safe operating area
3. Starting  $T_J = 25^{\circ}C$ ,  $I_D = 40A$ ,  $V_{DD} = 37.5V$
4.  $I_{SD} \leq 80A$ ,  $di/dt \leq 300A/\mu s$ ,  $V_{DD} \leq BV_{DSS}$ ,  $T_J \leq T_{JMAX}$

■ THERMAL DATA

PARAMETER		SYMBOL	RATINGS	UNIT
Junction to Ambient	TO-220/TO-263	$\theta_{JA}$	62.5	$^{\circ}\text{C}/\text{W}$
	TO-220F		62.5	$^{\circ}\text{C}/\text{W}$
Junction to Case	TO-220/TO-263	$\theta_{JC}$	0.5	$^{\circ}\text{C}/\text{W}$
	TO-220F		3.33	$^{\circ}\text{C}/\text{W}$

■ ELECTRICAL CHARACTERISTICS ( $T_C = 25^{\circ}\text{C}$ , unless otherwise specified)

PARAMETER		SYMBOL	TEST CONDITIONS	MIN	TYP	MAX	UNIT
<b>OFF CHARACTERISTICS</b>							
Drain-Source Breakdown Voltage		$BV_{DSS}$	$V_{GS} = 0\text{ V}, I_D = 250\ \mu\text{A}$	75			V
Drain-Source Leakage Current		$I_{DSS}$	$V_{DS} = 75\text{ V}, V_{GS} = 0\text{ V}$			1	$\mu\text{A}$
Gate-Source Leakage Current	Forward	$I_{GSS}$	$V_{GS} = 20\text{ V}, V_{DS} = 0\text{ V}$			100	nA
	Reverse		$V_{GS} = -20\text{ V}, V_{DS} = 0\text{ V}$			-100	nA
<b>ON CHARACTERISTICS</b>							
Gate Threshold Voltage		$V_{GS(TH)}$	$V_{DS} = V_{GS}, I_D = 250\ \mu\text{A}$	2.0	3.0	4.0	V
Static Drain-Source On-State Resistance		$R_{DS(ON)}$	$V_{GS} = 10\text{ V}, I_D = 40\text{ A}$		9.5	11	m $\Omega$
<b>DYNAMIC CHARACTERISTICS</b>							
Input Capacitance		$C_{ISS}$	$V_{GS} = 0\text{ V}, V_{DS} = 25\text{ V}$ $f = 1\text{ MHz}$		3700		pF
Output Capacitance		$C_{OSS}$			730		pF
Reverse Transfer Capacitance		$C_{RSS}$			240		pF
<b>SWITCHING CHARACTERISTICS</b>							
Turn-On Delay Time		$t_{D(ON)}$	$V_{DD} = 37.5\text{ V}, I_D = 45\text{ A},$ $V_{GS} = 10\text{ V}, R_G = 4.7\ \Omega$		25		ns
Turn-On Rise Time		$t_R$			100		ns
Turn-Off Delay Time		$t_{D(OFF)}$			66		ns
Turn-Off Fall Time		$t_F$			30		ns
Total Gate Charge		$Q_G$	$V_{DS} = 60\text{ V}, V_{GS} = 10\text{ V}$ $I_D = 80\text{ A}$		117	160	nC
Gate-Source Charge		$Q_{GS}$			27		nC
Gate-Drain Charge		$Q_{GD}$			47		nC

■ ELECTRICAL CHARACTERISTICS(Cont.)

PARAMETER		SYMBOL	TEST CONDITIONS	MIN	TYP	MAX	UNIT
<b>SOURCE-DRAIN DIODE RATINGS AND CHARACTERISTICS</b>							
Drain-Source Diode Forward Voltage (Note 2)		$V_{SD}$	$V_{GS} = 0\text{ V}, I_S = 80\text{ A}$			1.5	V
Continuous Source Current		$I_S$				80	A
Pulsed Source Current (Note 1)		$I_{SM}$				320	A
Reverse Recovery Time		$t_{RR}$	$I_S = 80\text{ A}, V_{DD} = 25\text{ V}$		132		ns
Reverse Recovery Charge		$Q_{RR}$	$dl_F / dt = 100\text{ A}/\mu\text{s}$		660		$\mu\text{C}$

Note: 1. Pulse width limited by safe operating area  
2. Pulsed: pulse duration=300 $\mu\text{s}$ , duty cycle 1.5%

■ TEST CIRCUITS AND WAVEFORMS

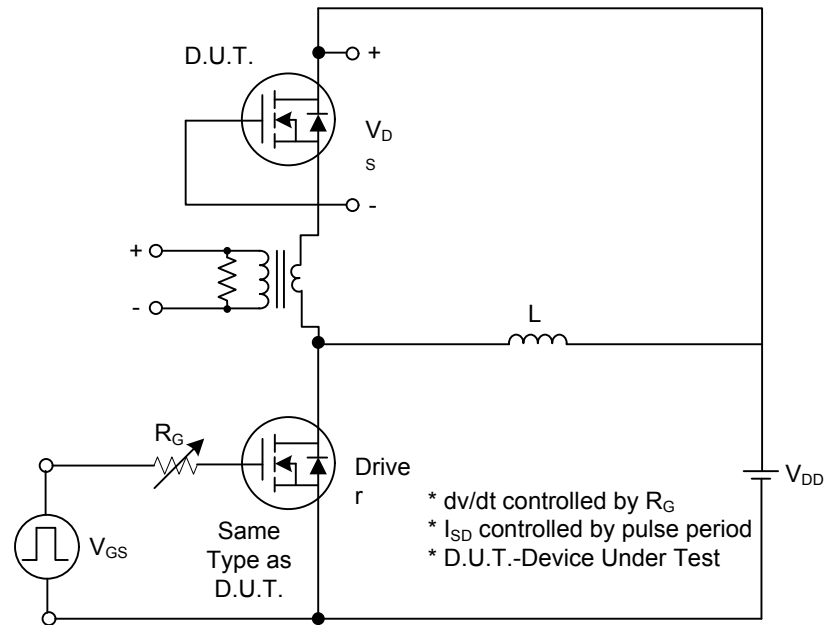

1A Peak Diode Recovery  $dv/dt$  Test Circuit

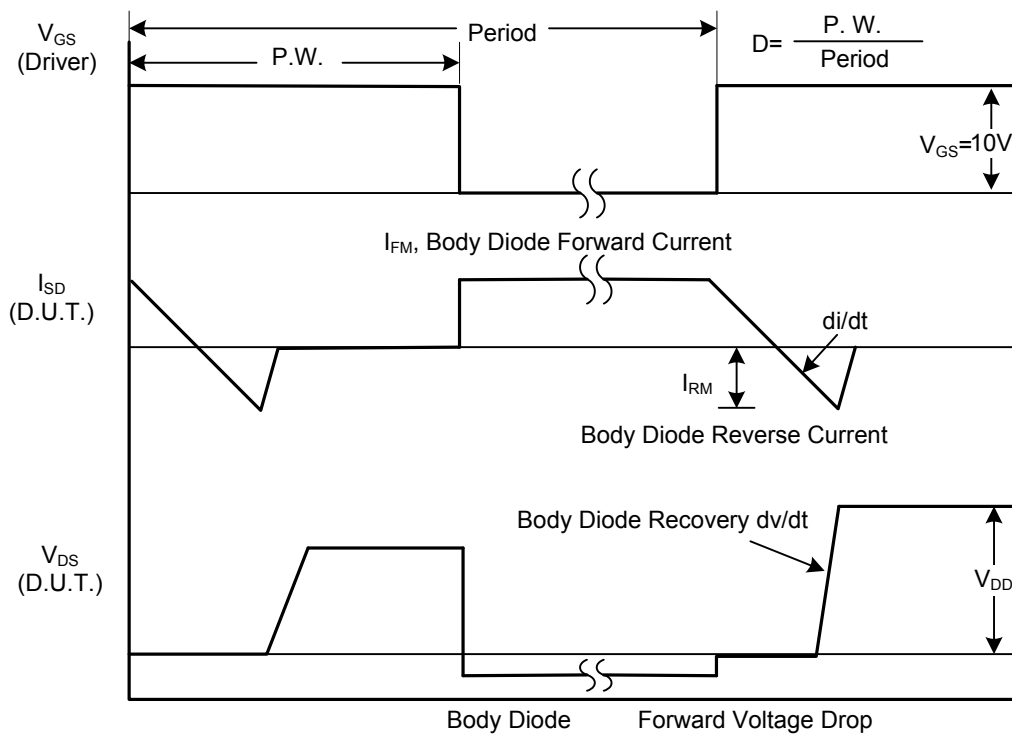

1B Peak Diode Recovery  $dv/dt$  Waveforms

■ TEST CIRCUITS AND WAVEFORMS (Cont.)

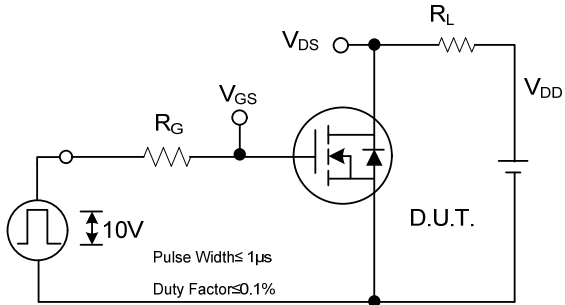

2A Switching Test Circuit

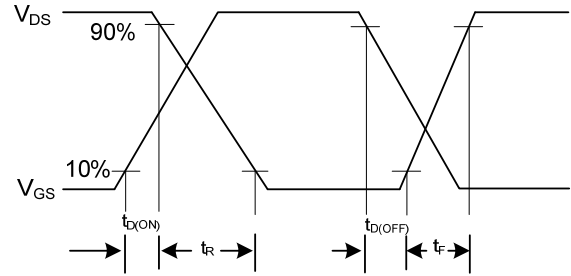

2B Switching Waveforms

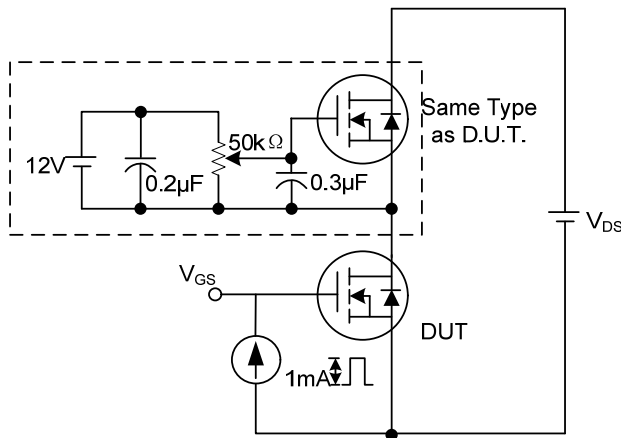

3A Gate Charge Test Circuit

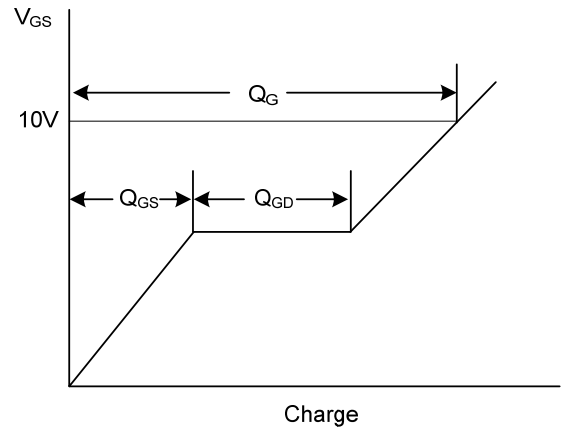

3B Gate Charge Waveform

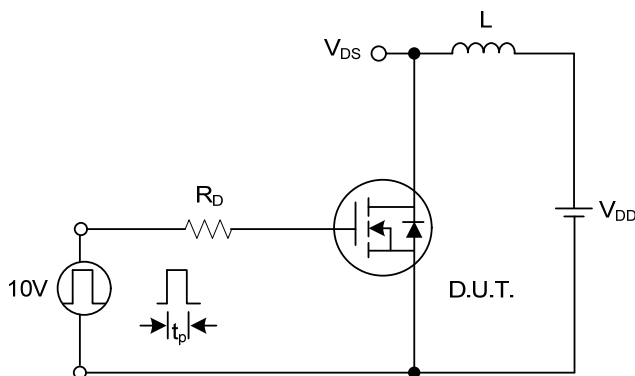

4A Unclamped Inductive Switching Test Circuit

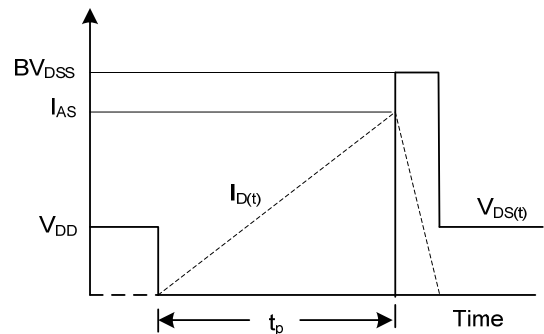

4B Unclamped Inductive Switching Waveforms

## ■ TYPICAL CHARACTERISTICS

