

Ceramic High Pass Filter

1060 to 3200 MHz

NEW!
HFCN-880



BLUE CELL™

CASE STYLE: FV1206

Maximum Ratings

Operating Temperature	-55°C to 100°C
Storage Temperature	-55°C to 100°C
RF Power Input*	7W max. at 25°C

*Passband rating, derate linearly to 3W at 100°C ambient.

Pin Connections

RF IN	1**
RF OUT	3**
GROUND	2,4

** RF IN & RF OUT can be interchanged

Features

- low cost
- small size
- 7 sections
- temperature stable
- excellent power handling, 7W

Applications

- sub-harmonic rejection
- transmitters/receivers
- lab use

Model	Price	Qty.
HFCN-880	\$1.99	(10-49)
HFCN-880D	\$2.49	(10-49)

High Pass Filter Electrical Specifications¹ (T_{AMB}=25°C)

MODEL NO.	STOP BAND (MHz)		f _{co} , MHz Nom. (loss < 3 dB) Typ.	PASSBAND (MHz)		VSWR Typ. Frequency (MHz) 1.5:1 Stopband	POWER INPUT (W)	NO. OF SECTIONS
	(loss > 40 dB) Min.	(loss > 20 dB)		(loss < 1.3 dB) Max.	(loss < 2 dB) Typ.			
HFCN-880	500	640	880	1060-2500	950-3200	20:1	7	7

1. For Applications requiring DC voltage to be applied to the Input or output, use HFCN-880D (DC Resistance to ground is 100 Mohms min.)

Outline Drawing

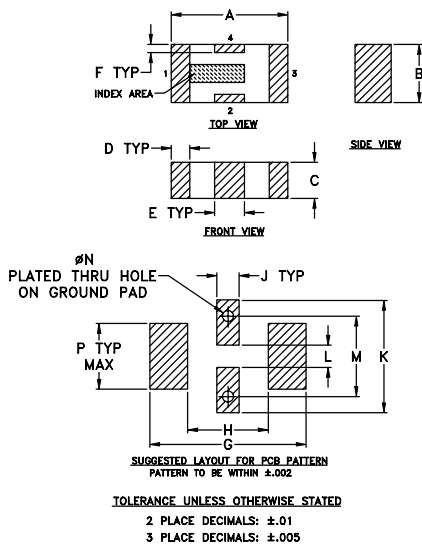

Outline Dimensions (inch)

A	B	C	D	E	F	G	H	J	K	L	M	N	P	wt
.126	.063	.037	.024	.087	.024	.009	.169	.087	.024	.024	.087	.012	.071	grams
3.20	1.60	0.94	0.51	0.81	0.23	4.29	2.21	0.61	3.10	0.61	2.21	0.30	1.80	.020

Demo Board MCL P/N: TB-270
Suggested PCB Layout (PL-137)

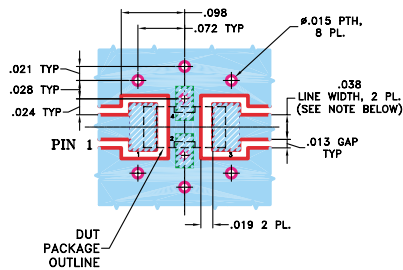

typical frequency response

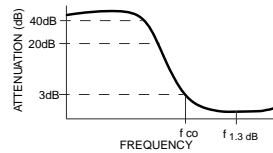

schematic

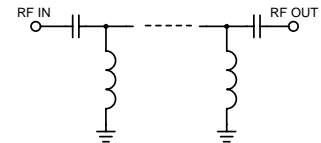

Typical Performance Data at 25°C

Frequency (MHz)	Insertion Loss (dB)	VSWR (:1)
1.00	82.28	>20
10.00	78.78	>20
501.00	50.29	>20
650.00	26.04	>20
880.00	3.50	2.39
970.00	1.56	1.58
1000.00	1.24	1.50
1600.00	0.55	1.39
2000.00	0.39	1.03
2400.00	0.54	1.44
2800.00	0.90	2.10
3200.00	1.68	2.96
3800.00	3.10	4.60
4200.00	4.05	5.83
5000.00	5.81	8.47

