

Features

- ▶ Gate driver with 20 Ω (on) / 10 Ω (off) on resistance @150°C for 1 NMOS LS FET
- ▶ PWM frequency up to 50 kHz
- ▶ μ C interface, SPI
- ▶ IC supply voltage range 7V to 28V (peak 42V) (limited operation range down to 5V)
- ▶ Sleep mode current less than 30 μ A
- ▶ Supply generation for external μ C 3.3V or 5V with maximal load current 30mA
- ▶ μ C window watchdog (adjustable)
- ▶ Amplifier for low side motor current measurement
- ▶ Adjustable comparator for fast over current switch off
- ▶ Power FET short circuit protection
- ▶ Gate driving for reverse polarity protection circuits
- ▶ Detection and protection for over temperature
- ▶ Available interfaces LIN 1.3-2.2A or PWM
- ▶ Wake-up via LIN or PWM interface
- ▶ LIN Flash Mode with 125kbaud
- ▶ Monitoring VBAT, VG, temperature
- ▶ QFN20L4 package ¹⁾: -40°C to + 150°C junction temperature (+170°C peak)

Applications

- ▶ DC motor HVAC fans
- ▶ DC motor Cooling fans
- ▶ DC motor Fuel, Hydraulik, Oil and Water pumps
- ▶ General DC motor control

General Description

This IC controls one NMOS – FET for driving DC motors, or other loads. The IC provides a power supply (3.3V or 5V), reset and watchdog for an external μ C. The QFN package guarantees good power dissipation performance. Product versions with LIN 1.3-2.2A or PWM interface are available. For controlling the motor a current amplifier is implemented. Diagnostic functions are detecting over current (programmable threshold), over temperature, over- and undervoltage.

Ordering Information

Product ID	Interface	Regulator Voltage
E523.03	LIN 2.x or PWM	5V
E523.13	PWM	5V
E523.04	LIN 2.x or PWM	3.3V
E523.14	PWM	3.3V

¹⁾ For alternative package please contact factory.

Typical Applications Circuit

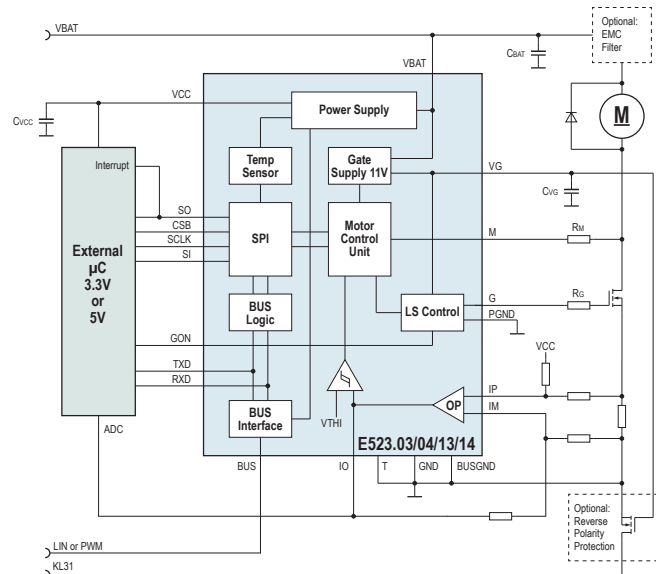

This document contains information on a product under development. ELMOS Semiconductor AG reserves the right to change or discontinue this product without notice.

ELMOS Semiconductor AG – Headquarters
Heinrich-Hertz-Str. 1 | 44227 Dortmund | Germany
Phone +49 (0) 231-75 49-100 | Fax +49 (0) 231-75 49-159
sales@elmos.com | www.elmos.com

Note ELMOS Semiconductor AG (below ELMOS) reserves the right to make changes to the product contained in this publication without notice. ELMOS assumes no responsibility for the use of any circuits described herein, conveys no licence under any patent or other right, and makes no representation that the circuits are free of patent infringement. While the information in this publication has been checked, no responsibility, however, is assumed for inaccuracies. ELMOS does not recommend the use of any of its products in life support applications where the failure or malfunction of the product can reasonably be expected to cause failure of a life-support system or to significantly affect its safety or effectiveness. Products are not authorized for use in such applications.

Copyright © 2012 ELMOS. Reproduction, in part or whole, without the prior written consent of ELMOS, is prohibited.