

OKI Semiconductor

MSC23B1321D-xxBS2/DS2

1,048,576-word x 32-bit DYNAMIC RAM MODULE : FAST PAGE MODE TYPE

DESCRIPTION

The MSC23B1321D-xxBS2/DS2 is a fully decoded, 1,048,576-word x 32-bit CMOS dynamic random access memory module composed of two 16Mb DRAMs in SOJ packages mounted with four decoupling capacitors on a 72-pin glass epoxy single-inline package. This module supports any application where high density and large capacity of storage memory are required.

FEATURES

- 1,048,576-word x 32-bit organization
- 72-pin socket insertable module
 - MSC23B1321D-xxBS2 : Gold tab
 - MSC23B1321D-xxDS2 : Solder tab
- Single +5V supply $\pm 10\%$ tolerance
- Input : TTL compatible
- Output : TTL compatible, 3-state
- Refresh : 1024cycles/16ms
- /CAS before /RAS refresh, hidden refresh, /RAS only refresh capability
- Fast page mode capability

PRODUCT FAMILY

Family	Access Time (Max.)			Cycle Time (Min.)	Power Dissipation	
	t _{RAC}	t _{AA}	t _{CAC}		Operating(Max.)	Standby(Max.)
MSC23B1321D-60BS2/DS2	60ns	30ns	15ns	110ns	1375mW	11mW
MSC23B1321D-70BS2/DS2	70ns	35ns	20ns	130ns	1265mW	

MODULE OUTLINE

MSC23B1321D-xxBS2/DS2

(Unit : mm)

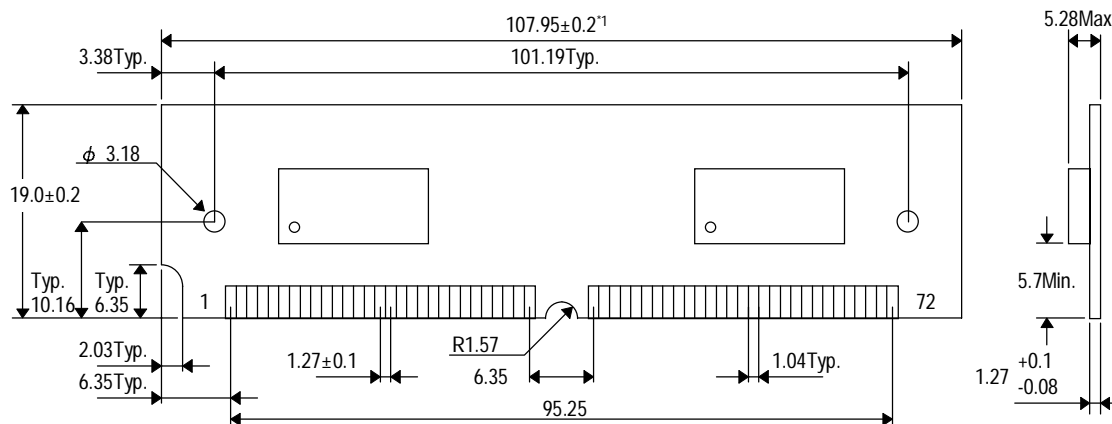

*1 The common size difference of the board width 12.5mm of its height is specified as ± 0.2 .
The value above 12.5mm is specified as ± 0.5 .

PIN CONFIGURATION

Pin No.	Pin Name	Pin No.	Pin Name	Pin No.	Pin Name	Pin No.	Pin Name
1	V _{SS}	19	NC	37	NC	55	DQ11
2	DQ0	20	DQ4	38	NC	56	DQ27
3	DQ16	21	DQ20	39	V _{SS}	57	DQ12
4	DQ1	22	DQ5	40	/CAS0	58	DQ28
5	DQ17	23	DQ21	41	/CAS2	59	V _{CC}
6	DQ2	24	DQ6	42	/CAS3	60	DQ29
7	DQ18	25	DQ22	43	/CAS1	61	DQ13
8	DQ3	26	DQ7	44	/RAS0	62	DQ30
9	DQ19	27	DQ23	45	NC	63	DQ14
10	V _{CC}	28	A7	46	NC	64	DQ31
11	NC	29	NC	47	/WE	65	DQ15
12	A0	30	V _{CC}	48	NC	66	NC
13	A1	31	A8	49	DQ8	67	PD1
14	A2	32	A9	50	DQ24	68	PD2
15	A3	33	NC	51	DQ9	69	PD3
16	A4	34	/RAS2	52	DQ25	70	PD4
17	A5	35	NC	53	DQ10	71	NC
18	A6	36	NC	54	DQ26	72	V _{SS}

Presence Detect Pins

Pin No.	Pin Name	MSC23B1321D -60BS2/DS2	MSC23B1321D -70BS2/DS2
67	PD1	V _{SS}	V _{SS}
68	PD2	V _{SS}	V _{SS}
69	PD3	NC	V _{SS}
70	PD4	NC	NC

BLOCK DIAGRAM

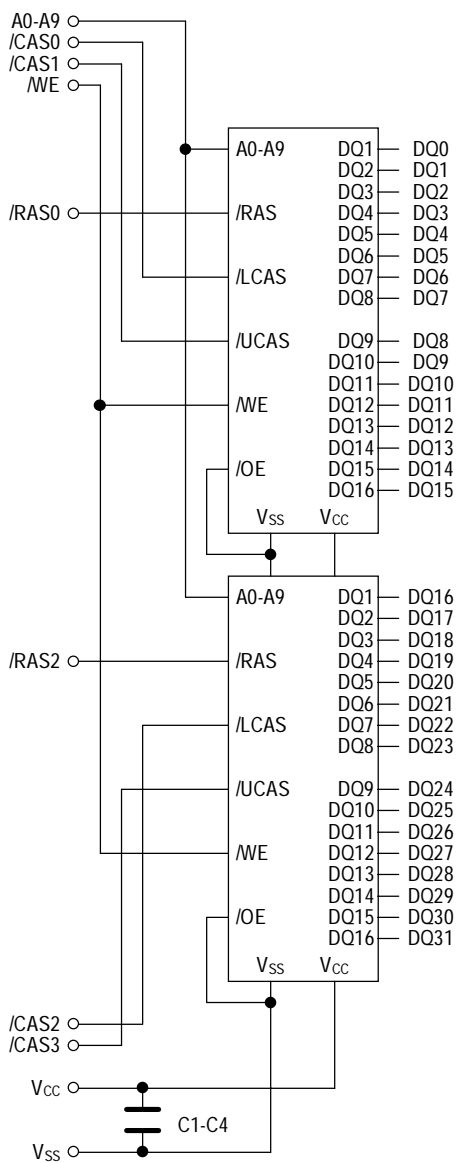

ELECTRICAL CHARACTERISTICS

Absolute Maximum Ratings

(Ta = 25°C)

Parameter	Symbol	Rating	Unit
Voltage on Any Pin Relative to V _{SS}	V _{IN} , V _{OUT}	-1.0 to +7.0	V
Voltage on V _{CC} Supply Relative to V _{SS}	V _{CC}	-1.0 to +7.0	V
Short Circuit Output Current	I _{OS}	50	mA
Power Dissipation	P _D	2	W
Operating Temperature	T _{OPR}	0 to +70	°C
Storage Temperature	T _{STG}	-40 to +125	°C

Recommended Operating Conditions

(Ta = 0°C to +70°C)

Parameter	Symbol	Min.	Typ.	Max.	Unit
Power Supply Voltage	V _{CC}	4.5	5.0	5.5	V
	V _{SS}	0	0	0	V
Input High Voltage	V _{IH}	2.4	-	6.5	V
Input Low Voltage	V _{IL}	-1.0	-	0.8	V

Capacitance

(V_{CC} = 5V ± 10%, Ta = 25°C, f = 1 MHz)

Parameter	Symbol	Typ.	Max.	Unit
Input Capacitance (A0 - A9)	C _{IN1}	-	16	pF
Input Capacitance (/WE)	C _{IN2}	-	20	pF
Input Capacitance (/RAS0, /RAS2)	C _{IN3}	-	13	pF
Input Capacitance (/CAS0- /CAS3)	C _{IN4}	-	13	pF
I/O Capacitance (DQ0 - DQ31)	C _{DQ}	-	13	pF

Note: Capacitance measured with Boonton Meter.

DC Characteristics

($V_{CC} = 5V \pm 10\%$, $T_a = 0^\circ C$ to $+70^\circ C$)

Parameter	Symbol	Condition	MSC23B1321D -60BS2/DS2		MSC23B1321D -70BS2/DS2		Unit	Note	
			Min.	Max.	Min.	Max.			
Input Leakage Current	I_{LI}	$0V \leq V_{IN} \leq 6.5V$: All other pins not under test = 0V	-20	20	-20	20	μA		
Output Leakage Current	I_{LO}	Data out is disable $0V \leq V_{OUT} \leq 5.5V$	-10	10	-10	10	μA		
Output High Voltage	V_{OH}	$I_{OH} = -5.0mA$	2.4	V_{CC}	2.4	V_{CC}	V		
Output Low Voltage	V_{OL}	$I_{OL} = 4.2mA$	0	0.4	0	0.4	V		
Average Power Supply Current (Operating)	I_{CC1}	/RAS cycling, /CAS cycling, $t_{RC} = \text{min.}$	-	250	-	230	mA	1, 2	
Power supply current (Standby)	I_{CC2}	/RAS = V_{IH} /CAS = V_{IH}	TTL	-	4	-	4	mA	1
			MOS	-	2	-	2	mA	1
Average Power Supply Current (/RAS only refresh)	I_{CC3}	/RAS cycling, /CAS = V_{IH} , $t_{RC} = \text{min.}$	-	250	-	230	mA	1, 2	
Average Power Supply Current (/CAS before /RAS refresh)	I_{CC6}	$t_{RC} = \text{min.}$	-	250	-	230	mA	1, 2	
Average Power Supply Current (Fast Page Mode)	I_{CC7}	/RAS = V_{IL} , /CAS cycling, $t_{PC} = \text{min.}$	-	250	-	230	mA	1, 3	

- Notes: 1. I_{CC} is dependent on output loading and cycles rates. Specified values are obtained with the output open.
 2. Address can be changed once or less while /RAS = V_{IL} .
 3. Address can be changed once or less while /CAS = V_{IH} .

AC Characteristics (1/2)

(V_{CC} = 5V ± 10%, T_a = 0°C to +70°C) Note: 1, 2, 3

Parameter	Symbol	MSC23B1321D -60BS2/DS2		MSC23B1321D -70BS2/DS2		Unit	Note
		Min.	Max.	Min.	Max.		
Random Read or Write Cycle Time	t _{RC}	110	-	130	-	ns	
Fast Page Mode Cycle Time	t _{PC}	40	-	45	-	ns	
Access Time from /RAS	t _{RAC}	-	60	-	70	ns	4, 5, 6
Access Time from /CAS	t _{CAC}	-	15	-	20	ns	4, 5
Access Time from Column Address	t _{AA}	-	30	-	35	ns	4, 6
Access Time from /CAS Precharge	t _{CPA}	-	35	-	40	ns	4
Output Low Impedance Time from /CAS	t _{CLZ}	0	-	0	-	ns	4
/CAS to Data Output Buffer Turn-off Delay Time	t _{OFF}	0	15	0	20	ns	7
Transition Time	t _T	3	50	3	50	ns	3
Refresh Period	t _{REF}	-	16	-	16	ms	
/RAS Precharge Time	t _{RP}	40	-	50	-	ns	
/RAS Pulse Width	t _{RAS}	60	10K	70	10K	ns	
/RAS Pulse Width (Fast Page Mode)	t _{RASP}	60	100K	70	100K	ns	
/RAS Hold Time	t _{RSH}	15	-	20	-	ns	
/CAS Precharge Time (Fast Page Mode)	t _{CP}	10	-	10	-	ns	
/CAS Pulse Width	t _{CAS}	15	10K	20	10K	ns	
/CAS Hold Time	t _{CSH}	60	-	70	-	ns	
/CAS to /RAS Precharge Time	t _{CRP}	5	-	5	-	ns	
/RAS Hold Time from /CAS Precharge	t _{RHCP}	35	-	40	-	ns	
/RAS to /CAS Delay Time	t _{RCD}	20	45	20	50	ns	5
/RAS to Column Address Delay Time	t _{RAD}	15	30	15	35	ns	6
Row Address Set-up Time	t _{ASR}	0	-	0	-	ns	
Row Address Hold Time	t _{RAH}	10	-	10	-	ns	
Column Address Set-up Time	t _{ASC}	0	-	0	-	ns	
Column Address Hold Time	t _{CAH}	10	-	15	-	ns	
Column Address to /RAS Lead Time	t _{RAL}	30	-	35	-	ns	
Read Command Set-up Time	t _{RCS}	0	-	0	-	ns	
Read Command Hold Time	t _{RCH}	0	-	0	-	ns	8
Read Command Hold Time referenced to /RAS	t _{RRH}	0	-	0	-	ns	8

AC Characteristics (2/2)

(V_{CC} = 5V ± 10%, T_a = 0°C to +70°C) Note: 1, 2, 3

Parameter	Symbol	MSC23B1321D -60BS2/DS2		MSC23B1321D -70BS2/DS2		Unit	Note
		Min.	Max.	Min.	Max.		
Write Command Set-up Time	t _{WCS}	0	-	0	-	ns	
Write Command Hold Time	t _{WCH}	10	-	15	-	ns	
Write Command Pulse Width	t _{WP}	10	-	10	-	ns	
Write Command to /RAS Lead Time	t _{RWL}	15	-	20	-	ns	
Write Command to /CAS Lead Time	t _{CWL}	15	-	20	-	ns	
Data-in Set-up Time	t _{DS}	0	-	0	-	ns	
Data-in Hold Time	t _{DH}	10	-	15	-	ns	
/CAS Active Delay Time from /RAS Precharge	t _{RPC}	5	-	5	-	ns	
/RAS to /CAS Set-up Time (/CAS before /RAS)	t _{CSR}	10	-	10	-	ns	
/RAS to /CAS Hold Time (/CAS before /RAS)	t _{CHR}	10	-	10	-	ns	

- Notes:
1. A start-up delay of 200 μ s is required after power-up, followed by a minimum of eight initialization cycles (/RAS only refresh or /CAS before /RAS refresh) before proper device operation is achieved.
 2. The AC characteristics assumes $t_T = 5$ ns.
 3. $V_{IH}(\text{Min.})$ and $V_{IL}(\text{Max.})$ are reference levels for measuring input timing signals. Transition time (t_T) are measured between V_{IH} and V_{IL} .
 4. This parameter is measured with a load circuit equivalent to 2TTL loads and 100pF.
 5. Operation within the $t_{RCD}(\text{Max.})$ limit ensures that $t_{RAC}(\text{Max.})$ can be met. $t_{RCD}(\text{Max.})$ is specified as a reference point only. If t_{RCD} is greater than the specified $t_{RCD}(\text{Max.})$ limit, then the access time is controlled by t_{CAC} .
 6. Operation within the $t_{RAD}(\text{Max.})$ limit ensures that $t_{RAC}(\text{Max.})$ can be met. $t_{RAD}(\text{Max.})$ is specified as a reference point only. If t_{RAD} is greater than the specified $t_{RAD}(\text{Max.})$ limit, then the access time is controlled by t_{AA} .
 7. $t_{OFF}(\text{Max.})$ define the time at which the output achieves the open circuit condition and are not referenced to output voltage levels.
 8. t_{RCH} or t_{RRH} must be satisfied for a read cycle.