

SMD POWER INDUCTORS

MODEL NO. : SPC-06503 SERIES (A920CY COMPATIBLE)

FEATURES:

- * SUPERIOR QUALITY FOR AN AUTOMATED PRODUCTION LINE.
- * PICK AND PLACE COMPATIBLE.
- * TAPE AND REEL PACKING.

APPLICATION :

- * NOTEBOOK COMPUTERS.
- * DC-DC CONVERTORS.
- * PDA.
- * DIGITAL STILL CAMERAS.



ELECTRICAL SPECIFICATION:

(UNIT:mm)

PART NO	INDUCTANCE (μ H) $\pm 20\%$	D.C.R. MAX (Ω)	RATED CURRENT (ADC)	TEMPERATURE RISE CURRENT (ADC) MAX
SPC-06503-1R0	1.0	0.013	3.48	3.84
SPC-06503-1R5	1.5	0.017	2.93	3.40
SPC-06503-2R0	2.0	0.020	2.44	3.10
SPC-06503-3R3	3.3	0.028	2.00	2.55
SPC-06503-4R3	4.3	0.037	1.65	2.23
SPC-06503-6R2	6.2	0.050	1.50	1.85
SPC-06503-100	10	0.074	1.16	1.48
SPC-06503-120	12	0.086	1.05	1.35
SPC-06503-150	15	0.100	0.87	1.24
SPC-06503-180	18	0.125	0.88	1.11
SPC-06503-220	22	0.150	0.80	1.00
SPC-06503-270	27	0.195	0.70	0.86
SPC-06503-330	33	0.224	0.66	0.80
SPC-06503-390	39	0.280	0.60	0.70
SPC-06503-470	47	0.330	0.55	0.63
SPC-06503-560	56	0.395	0.50	0.58
SPC-06503-680	68	0.450	0.45	0.53
SPC-06503-820	82	0.530	0.40	0.49

PHYSICAL DIMENSION :

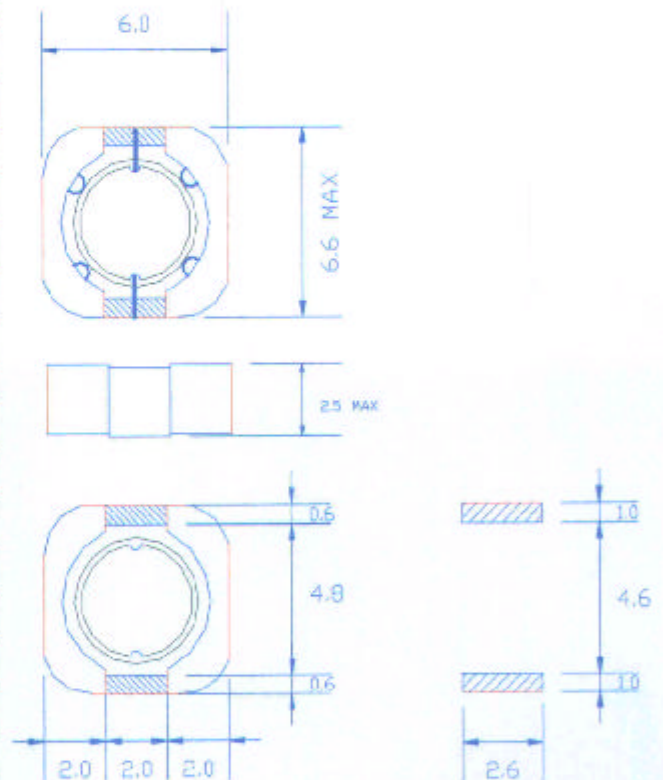

TOLERANCE : ± 0.3

PCB PATTERN

NOTE (1): TEST FREQUENCY: 100KHZ,1VRMS.

NOTE (2): THIS INDICATES THE VALUE OF DC CURRENT WHICH THE INDUCTANCE IS 30% LOWER THAN ITS INITIAL VALUE AND/OR $\Delta T=40^{\circ}\text{C}$ UNDER THIS DC CURRENT BIAS.