

**Features**

- Low Noise and High Intercept Point
- Adjustable Bias Current
- Power Down Control
- Single 2.5V to 6.0V Power Supply
- 150MHz to 2500MHz Operation
- Extremely Small SOT23-5 Package

**Applications**

- TDMA/CDMA/FM PCS Tx Amplifier
- Low Noise Transmit Driver Amplifier
- 2.4GHz WLAN Systems
- General Purpose Amplification
- Commercial and Consumer Systems

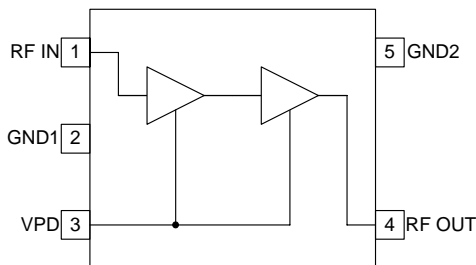

Functional Block Diagram

**Product Description**

The RF2362 is a low noise CDMA/TDMA PA driver amplifier with a very high dynamic range designed for transmit digital PCS applications at 1880MHz. The device functions as an outstanding PA driver amplifier in the transmit chain of digital subscriber units where low transmit noise power is a concern. The IC includes a power down feature that can be used to completely turn off the device. The IC is featured in a standard SOT 5-lead plastic package.

**Ordering Information**

RF2362                      PCS CDMA/TDMA 3V PA Driver Amplifier  
 RF2362PCBA-41X      Fully Assembled Evaluation Board

**Optimum Technology Matching® Applied**

- |  |                                      |                                     |                                   |
|--|--------------------------------------|-------------------------------------|-----------------------------------|
| <input checked="" type="checkbox"/> GaAs HBT | <input type="checkbox"/> SiGe BiCMOS | <input type="checkbox"/> GaAs pHEMT | <input type="checkbox"/> GaN HEMT |
| <input type="checkbox"/> GaAs MESFET         | <input type="checkbox"/> Si BiCMOS   | <input type="checkbox"/> Si CMOS    |                                   |
| <input type="checkbox"/> InGaP HBT           | <input type="checkbox"/> SiGe HBT    | <input type="checkbox"/> Si BJT     |                                   |

RF MICRO DEVICES®, RFMD®, Optimum Technology Matching®, Enabling Wireless Connectivity™, PowerStar®, POLARIS™ TOTAL RADIO™ and UltimateBlue™ are trademarks of RFMD, LLC. BLUETOOTH is a trademark owned by Bluetooth SIG, Inc., U.S.A. and licensed for use by RFMD. All other trade names, trademarks and registered trademarks are the property of their respective owners. ©2006, RF Micro Devices, Inc.

## Absolute Maximum Ratings

Parameter	Rating	Unit
Supply Voltage	-0.5 to +8.0	V <sub>DC</sub>
Input RF Level	+10	dBm
Operating Ambient Temperature	-40 to +85	°C
Storage Temperature	-40 to +150	°C



**Caution!** ESD sensitive device.

Exceeding any one or a combination of the Absolute Maximum Rating conditions may cause permanent damage to the device. Extended application of Absolute Maximum Rating conditions to the device may reduce device reliability. Specified typical performance or functional operation of the device under Absolute Maximum Rating conditions is not implied.

RoHS status based on EU Directive 2002/95/EC (at time of this document revision).

The information in this publication is believed to be accurate and reliable. However, no responsibility is assumed by RF Micro Devices, Inc. ("RFMD") for its use, nor for any infringement of patents, or other rights of third parties, resulting from its use. No license is granted by implication or otherwise under any patent or patent rights of RFMD. RFMD reserves the right to change component circuitry, recommended application circuitry and specifications at any time without prior notice.

Parameter	Specification			Unit	Condition
	Min.	Typ.	Max.		
<b>Overall</b>					
RF Frequency Range		150 to 2500		MHz	
<b>1880MHz Performance</b>					Schematic per Evaluation Board, T = 25 °C, RF = 1880MHz, V <sub>PD</sub> = 2.8V
Gain	19	20.1	21.5	dB	V <sub>CC</sub> = 3.5V
	19	20.1	21.5	dB	V <sub>CC</sub> = 3.0V
	19	20.1	21.5	dB	V <sub>CC</sub> = 2.7V
Output IP3	+24	+25.5	+35	dBm	V <sub>CC</sub> = 3.5V
		+25.0		dBm	V <sub>CC</sub> = 3.0V
		+24.5		dBm	V <sub>CC</sub> = 2.7V
Noise Figure		2.2	2.5	dB	V <sub>CC</sub> = 3.5V
		2.2	2.5	dB	V <sub>CC</sub> = 3.0V
		2.2	2.5	dB	V <sub>CC</sub> = 2.7V
Reverse Isolation		32		dB	V <sub>CC</sub> = 3.5V
		32		dB	V <sub>CC</sub> = 3.0V
		32		dB	V <sub>CC</sub> = 2.7V
Input VSWR		1.8:1	2.0:1		
Output VSWR		1.6:1	2.0:1		Using External LC network used on Evaluation Board
P <sub>1dB</sub>	14	14.5		dBm	V <sub>CC</sub> = 3.5V
	12.5	14		dBm	V <sub>CC</sub> = 3.0V
	11	13.5		dBm	V <sub>CC</sub> = 2.7V
<b>Power Supply</b>					T = 25 °C
Voltage (V <sub>CC</sub> )		2.5 to 6.0		V	
Voltage (V <sub>PD</sub> )	2.7	2.8	2.9	V	
Current Consumption		35	43	mA	V <sub>CC</sub> = 3.5V; V <sub>PD</sub> = 2.8V; V <sub>PD</sub> + V <sub>CC</sub> - Current Consumption from V <sub>PD</sub> is 8.5 mA Typ. @ V <sub>PD</sub> = 2.8V and 12 mA Max @ V <sub>PD</sub> = 2.9V
		32	38	mA	V <sub>CC</sub> = 3.0V; V <sub>PD</sub> = 2.7V; V <sub>PD</sub> + V <sub>CC</sub>
	29	37	43	mA	V <sub>CC</sub> = 2.7V; V <sub>PD</sub> = 2.9V; V <sub>PD</sub> + V <sub>CC</sub>
Power Down			10	µA	V <sub>CC</sub> = 3.5V; V <sub>PD</sub> ≤ 0.9V

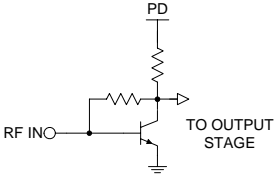
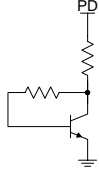
Pin	Function	Description	Interface Schematic
1	RF IN	RF input pin. This pin is DC-coupled and matched to 50Ω at 1880MHz.	
2	GND1	Ground connection. For best performance, keep traces physically short and connect immediately to ground plane.	
3	VPD	Power Down for the IC. $V_{PD} = 2.8V \pm 0.1V$ turns on the part. $V_{PD} < 0.9V$ turns off the part. External RF bypassing is required. The trace length between the pin and the bypass capacitors should be minimized. The ground side of the bypass capacitors should connect immediately to ground plane. Nominal current required for $V_{PD} = 2.8V$ is 8.5 mA typical and 12 mA Max (@ $V_{PD} = 2.9V$ ).	
4	RF OUT	Amplifier Output pin. This pin is an open-collector output. It must be biased to either $V_{CC}$ or pin 4 through a choke or matching inductor. This pin is typically matched to 50Ω with a shunt bias/matching inductor and series blocking/matching capacitor. Refer to application schematics.	
5	GND2	Ground connection. For best performance, keep traces physically short and connect immediately to ground plane.	

### Package Drawing

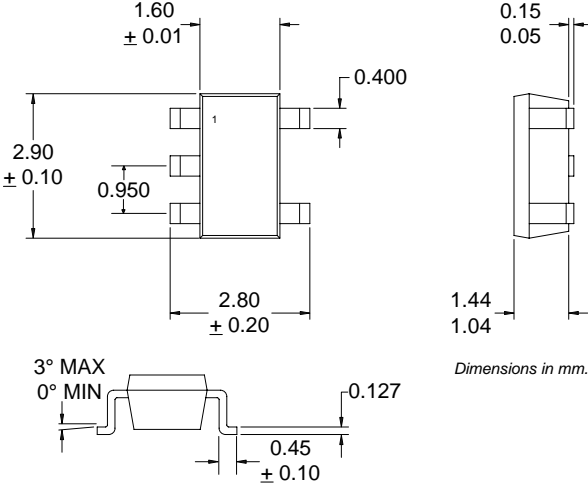

**Application Schematic:  
~1880 MHz Operation, Internal Collector Bias**

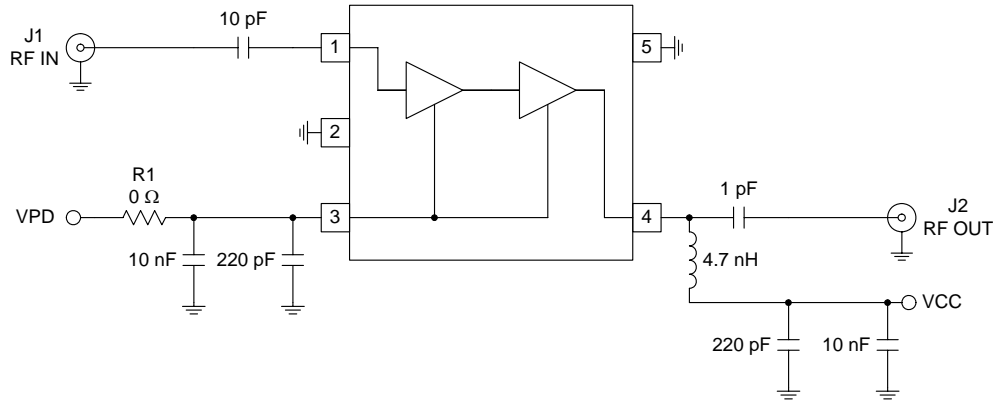

## Evaluation Board Schematic

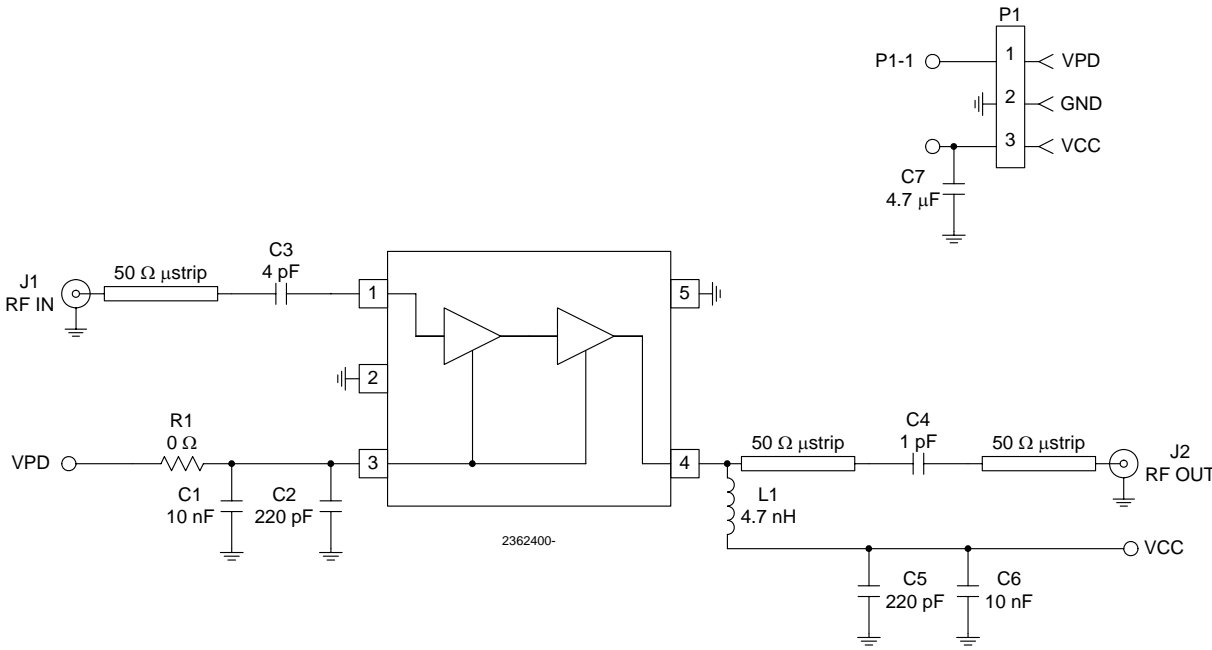

**Evaluation Board Layout**  
**Board Size 1" x 1"**  
**Board Thickness 0.014"; Board Material FR-4**

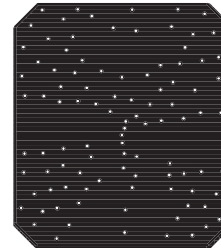
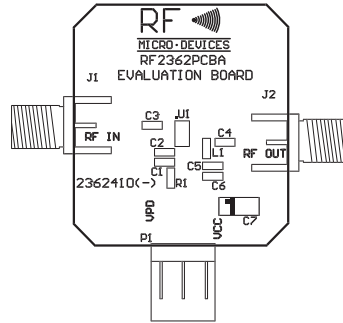

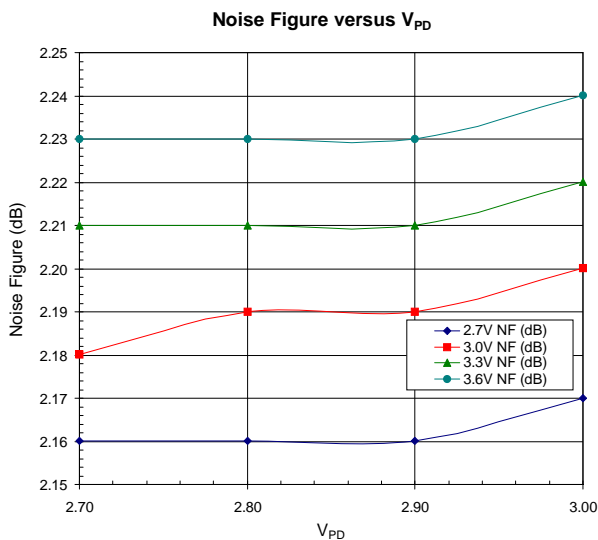
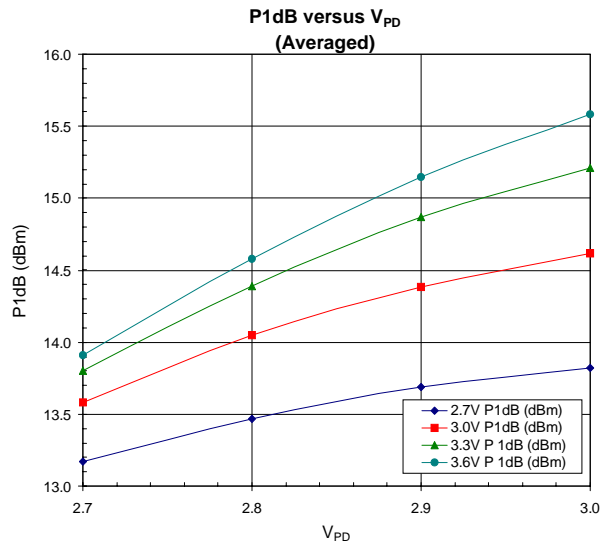
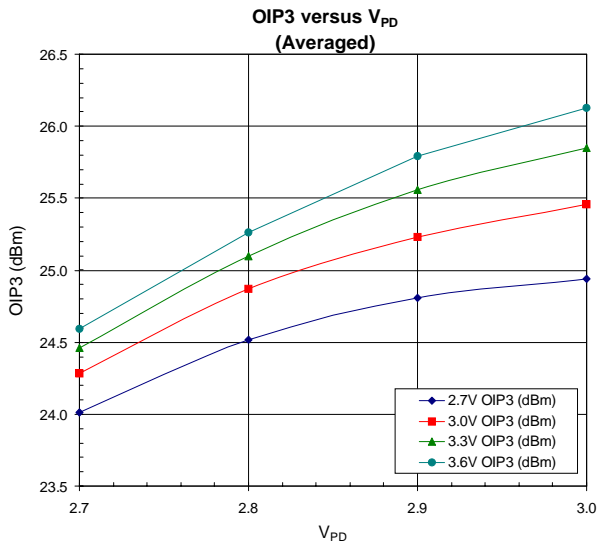
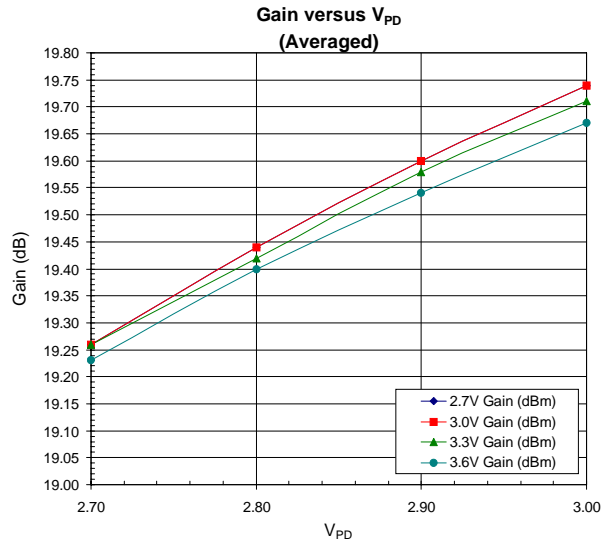
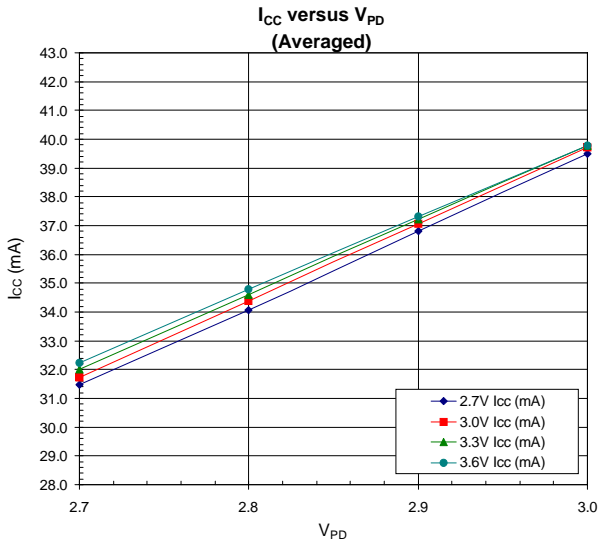

**RoHS\* Banned Material Content**

RoHS Compliant: No  
 Package total weight in grams (g): 0.014  
 Compliance Date Code: N/A  
 Bill of Materials Revision: -  
 Pb Free Category: Contains Pb

Bill of Materials	Parts Per Million (PPM)					
	Pb	Cd	Hg	Cr VI	PBB	PBDE
Die	0	0	0	0	0	0
Molding Compound	0	0	0	0	0	0
Lead Frame	0	0	0	0	0	0
Die Attach Epoxy	0	0	0	0	0	0
Wire	0	0	0	0	0	0
Solder Plating	4732	0	0	0	0	0

**This RoHS banned material content declaration was prepared solely on information, including analytical data, provided to RFMD by its suppliers, and applies to the Bill of Materials (BOM) revision noted**

\* DIRECTIVE 2002/95/EC OF THE EUROPEAN PARLIAMENT AND OF THE COUNCIL of 27 January 2003 on the restriction of the use of certain hazardous substances in electrical and electronic equipment

