

# TIBPAL22V10-5C

## HIGH-PERFORMANCE *IMPACT-XL*™ PROGRAMMABLE ARRAY LOGIC CIRCUIT

SRPS028A – MAY 1992 – REVISED OCTOBER 1993

- **High-Performance Operation:**  
 $f_{max}$  (External Feedback) . . . 117 MHz  
 Propagation Delay . . . 5 ns Max
- **Increased Logic Power – Up to 22 Inputs and 10 Outputs**
- **Increased Product Terms – Average of 12 Per Output**
- **Variable Product Term Distribution Allows More Complex Functions to Be Implemented**
- **Each Output Is User Programmable for Registered or Combinational Operation, Polarity, and Output Enable Control**
- **Power-Up Clear on Registered Outputs**
- **TTL-Level Preload for Improved Testability**
- **Extra Terms Provide Logical Synchronous Set and Asynchronous Reset Capability**
- **Fast Programming, High Programming Yield, and Unsurpassed Reliability Ensured Using Ti-W Fuses**
- **AC and DC Testing Done at the Factory Utilizing Special Designed-In Test Features**
- **JEDEC Approved Revolutionary Power and Ground Pinout for 28-Pin Chip Carrier Reduces Cross Talk and Ground Bounce**
- **JEDEC File Compatibility Allows Previous '22V10 Designs to be Programmed Into the TIBPAL22V10-5C Without Modifications**

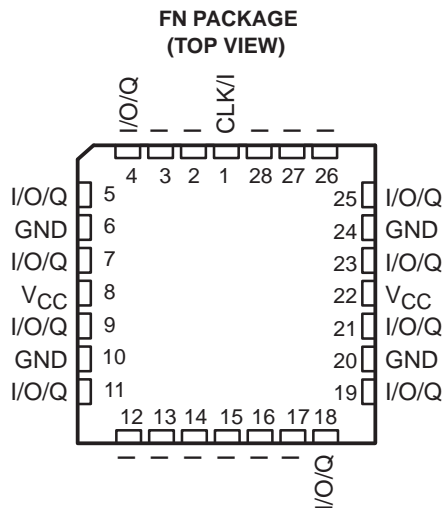

### description

The TIBPAL22V10-5C is a programmable array logic device featuring high speed and functional equivalency when compared to presently available devices. The TIBPAL22V10-5C is implemented with the familiar sum-of-products (AND-OR) logic structure featuring programmable output logic macrocells. These *IMPACT-XL*™ circuits combine the latest Advanced Low-Power Schottky technology with proven titanium-tungsten fuses to provide reliable, high-performance substitutes for conventional TTL logic.

This device contains up to 22 inputs and 10 outputs. It incorporates the unique capability of defining and programming the architecture of each output on an individual basis. Outputs can be registered or nonregistered and inverting or noninverting as shown in the output logic macrocell diagram. The ten potential outputs are enabled through the use of individual product terms.

Further advantages can be seen in the introduction of variable product term distribution. This technique allocates from 8 to 16 logical product terms to each output for an average of 12 product terms per output. This variable allocation of terms allows far more complex functions to be implemented than in previously available devices.

This device is covered by U.S. Patent 4,410,987.  
*IMPACT-XL* is a trademark of Texas Instruments Incorporated.

PRODUCTION DATA information is current as of publication date. Products conform to specifications per the terms of Texas Instruments standard warranty. Production processing does not necessarily include testing of all parameters.



Copyright © 1993, Texas Instruments Incorporated

# TIBPAL22V10-5C HIGH-PERFORMANCE *IMPACT-XL*<sup>™</sup> PROGRAMMABLE ARRAY LOGIC CIRCUIT

SRPS028A – MAY 1992 – REVISED OCTOBER 1993

---

## description (continued)

Circuit design is enhanced by the addition of a synchronous set and an asynchronous reset product term. These functions are common to all registers. When the synchronous set product term is a logic 1, the output registers are loaded with a logic 1 on the next low-to-high clock transition. When the asynchronous reset product term is a logic 1, the output registers are loaded with a logic 0. The output logic level after set or reset depends on the polarity selected during programming. Output registers can be preloaded to any desired state during testing. Preloading permits full logical verification during product testing.

With features such as programmable output logic macrocells and variable product term distribution, the TIBPAL22V10-5C offers quick design and development of custom LSI functions with complexities of 500 to 800 equivalent gates. Since each of the ten output pins can be individually configured as inputs on either a temporary or permanent basis, functions requiring up to 21 inputs and a single output or down to 12 inputs and 10 outputs are possible.

A power-up clear function is supplied that forces all registered outputs to a predetermined state after power is applied to the device. Registered outputs selected as active-low power up with their outputs high. Registered outputs selected as active-high power up with their outputs low.

A single security fuse is provided on each device to discourage unauthorized copying of fuse patterns. Once blown, the verification circuitry is disabled and all other fuses will verify as open.

The TIBPAL22V10-5C is characterized for operation from 0°C to 75°C.



POST OFFICE BOX 655303 • DALLAS, TEXAS 75265

# TIBPAL22V10-5C

## HIGH-PERFORMANCE *IMPACT-XL*<sup>TM</sup> PROGRAMMABLE ARRAY LOGIC CIRCUIT

SRPS028A – MAY 1992 – REVISED OCTOBER 1993

functional block diagram (positive logic)

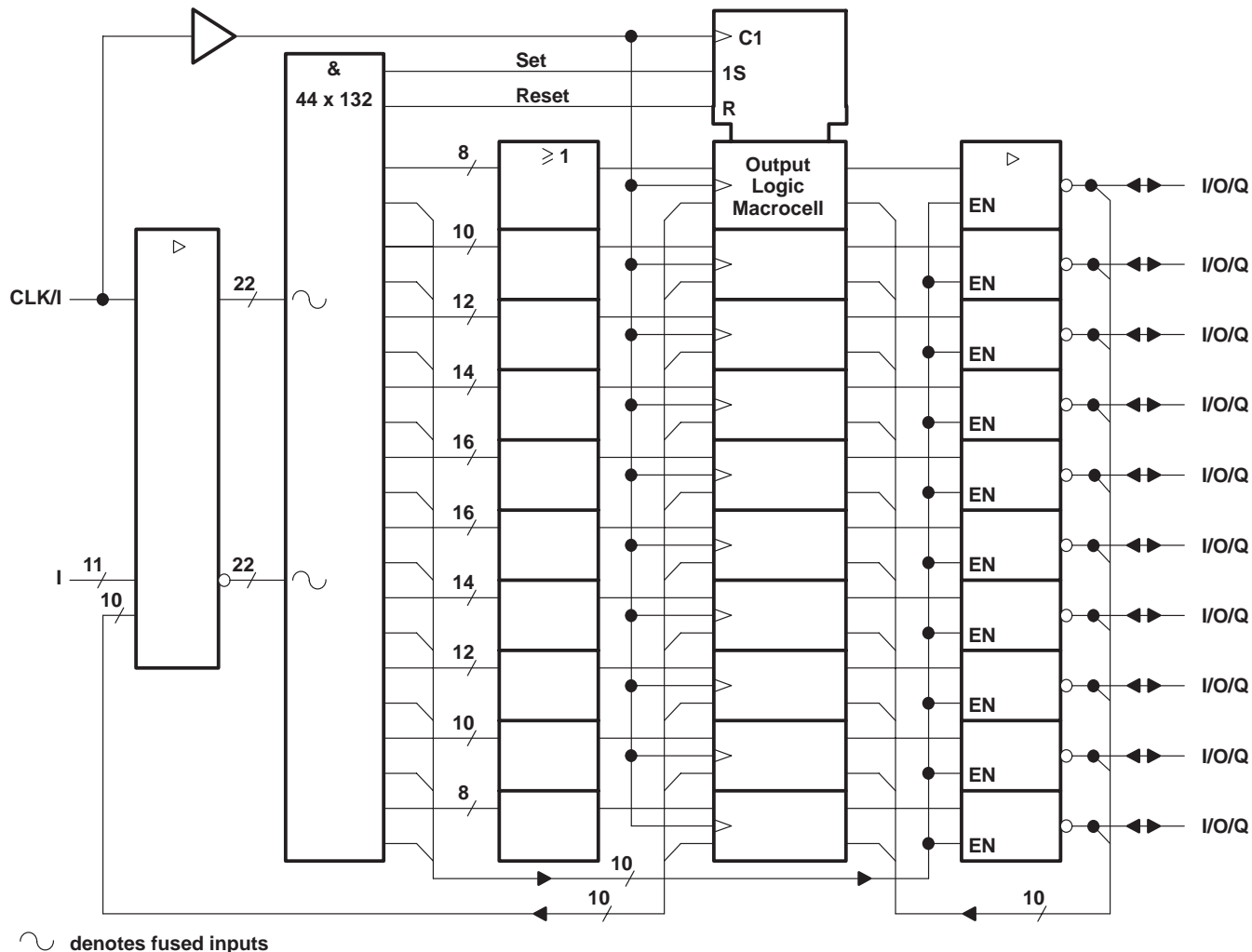

**TIBPAL22V10-5C**  
**HIGH-PERFORMANCE IMPACT-XL™ PROGRAMMABLE ARRAY LOGIC CIRCUIT**

SRPS028A – MAY 1992 – REVISED OCTOBER 1993

logic diagram (positive logic)

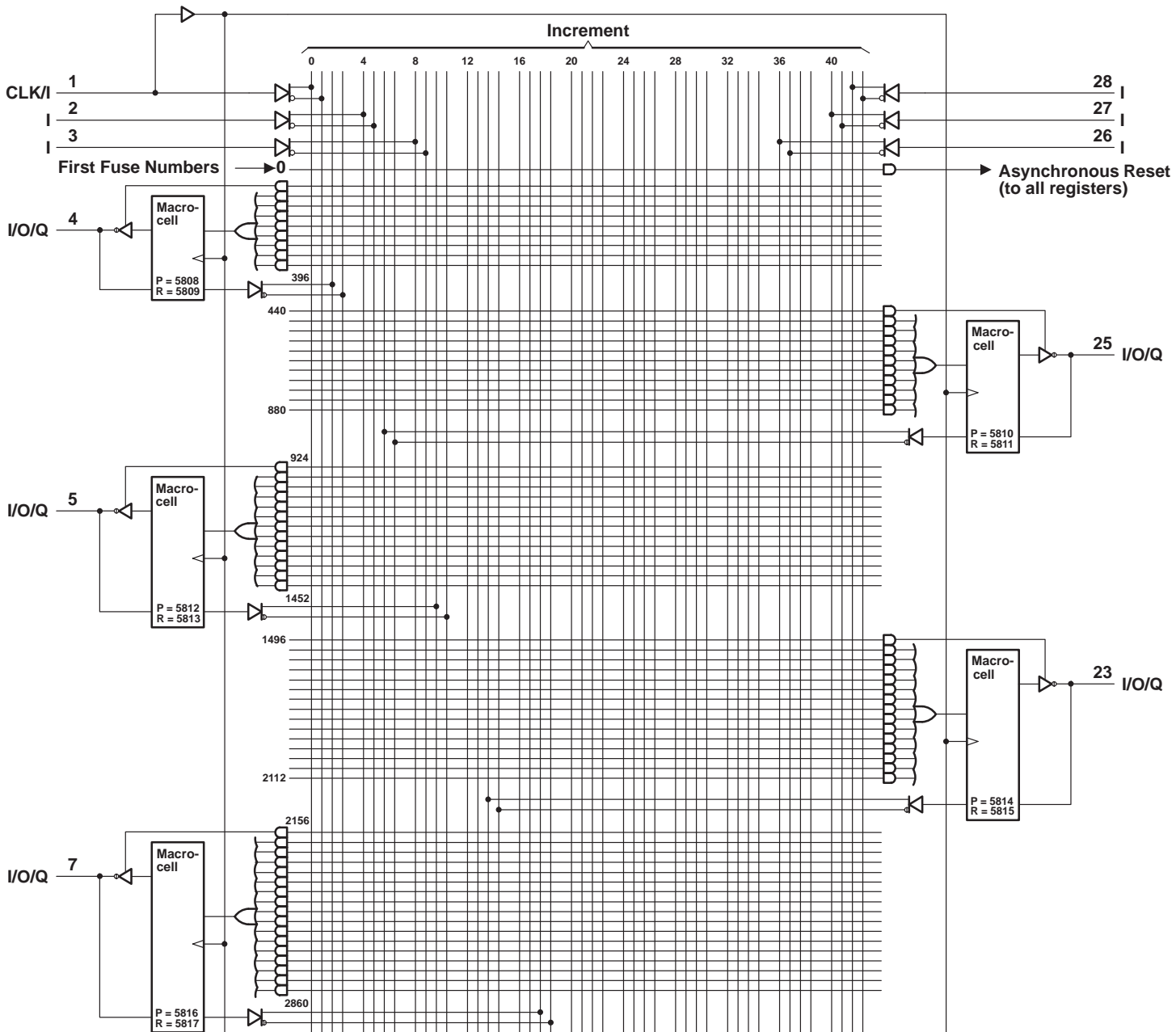

# HIGH-PERFORMANCE IMPACT-XL™ PROGRAMMABLE ARRAY LOGIC CIRCUIT

## TIBPAL22V10-5C

SRP5028A – MAY 1992 – REVISED OCTOBER 1993

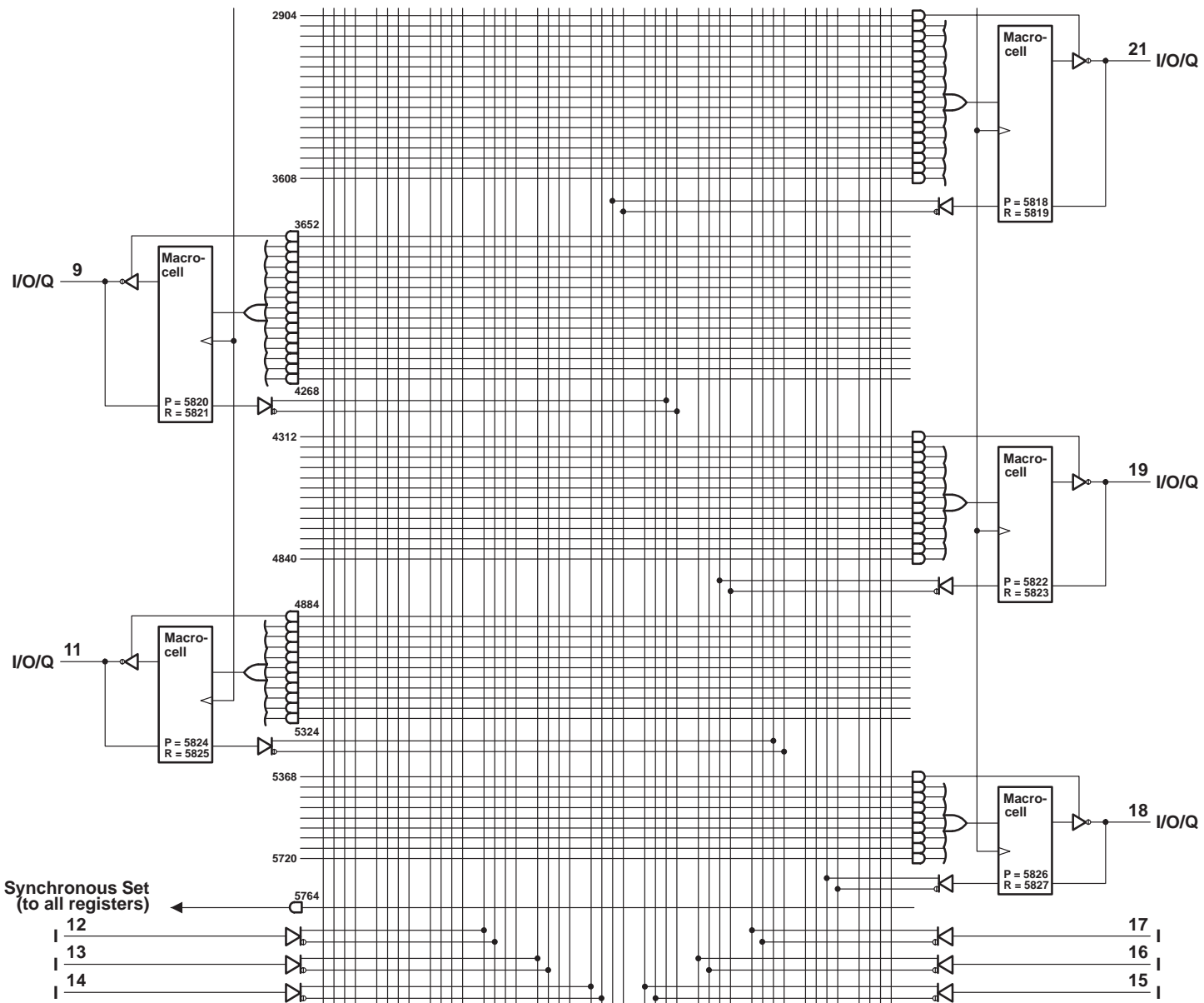

Fuse number = First fuse number + Increment  
 Inside each MACROCELL the "P" fuse is the polarity fuse and the "R" fuse is the register fuse.

TIBPAL22V10-5C  
 HIGH-PERFORMANCE *IMPACT-XL*™ PROGRAMMABLE ARRAY LOGIC CIRCUIT

SRPS028A – MAY 1992 – REVISED OCTOBER 1993

output logic macrocell diagram

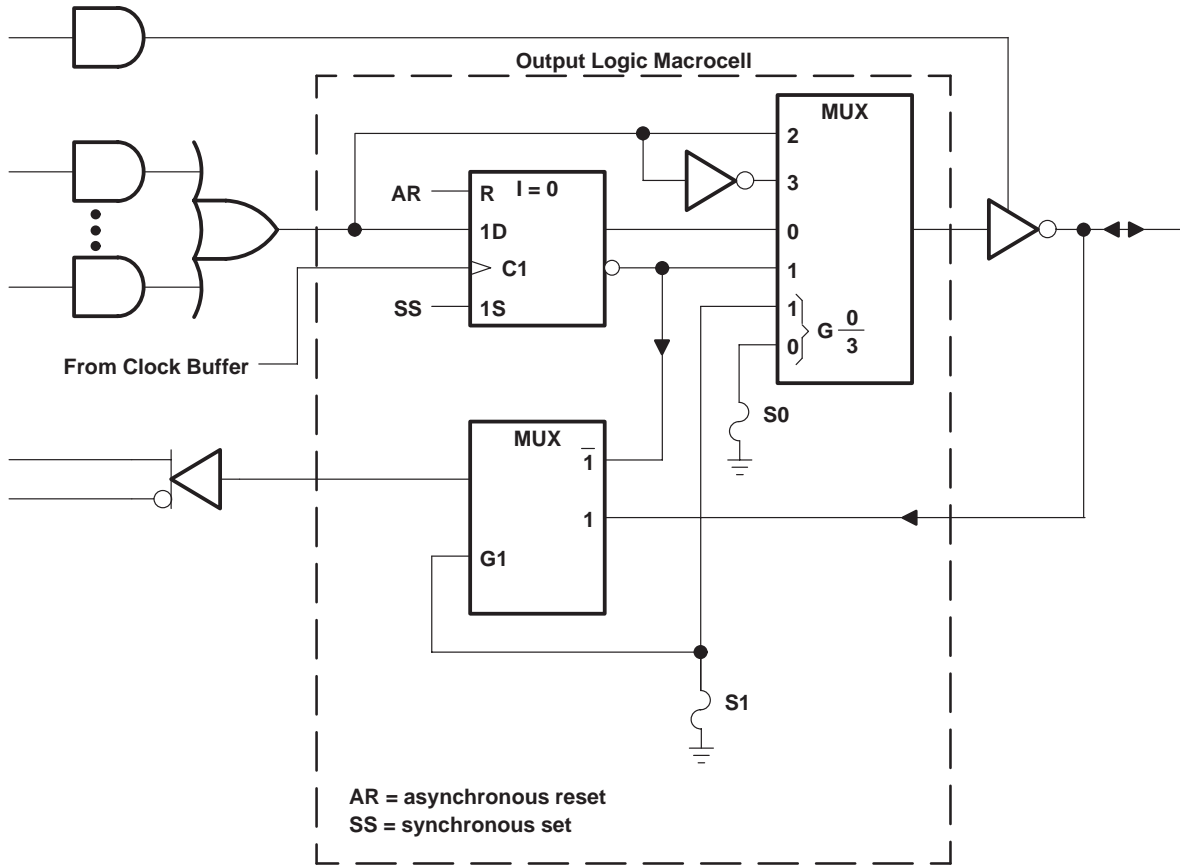

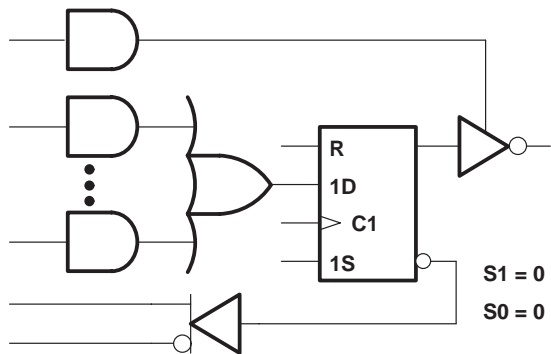

REGISTER FEEDBACK, REGISTERED, ACTIVE-LOW OUTPUT

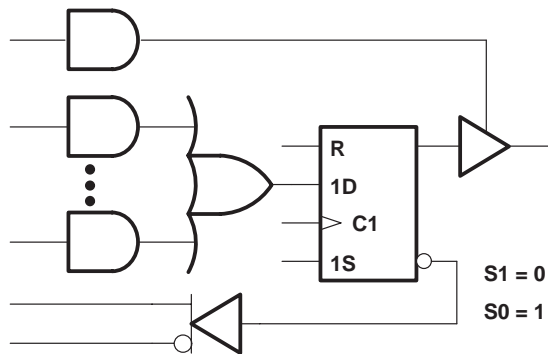

REGISTER FEEDBACK, REGISTERED, ACTIVE-HIGH OUTPUT

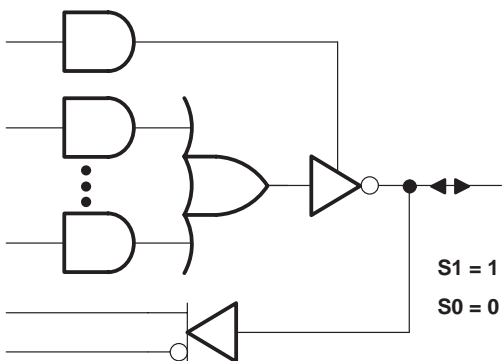

I/O FEEDBACK, COMBINATIONAL, ACTIVE-LOW OUTPUT

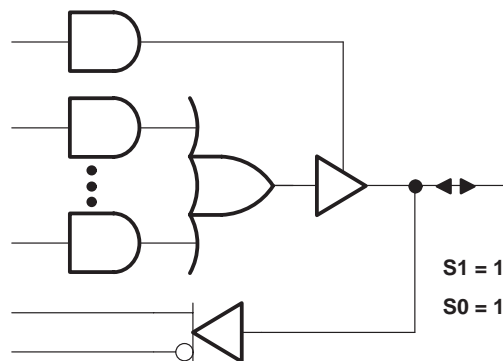

I/O FEEDBACK, COMBINATIONAL, ACTIVE-HIGH OUTPUT

MACROCELL FEEDBACK AND OUTPUT FUNCTION TABLE

FUUSE SELECT		FEEDBACK AND OUTPUT CONFIGURATION		
S1	S0			
0	0	Register feedback	Registered	Active low
0	1	Register feedback	Registered	Active high
1	0	I/O feedback	Combinational	Active low
1	1	I/O feedback	Combinational	Active high

0 = unblown fuse, 1 = blown fuse

S1 and S0 are select-function fuses as shown in the output logic macrocell diagram.

Figure 1. Resultant Macrocell Feedback and Output Logic After Programming

# TIBPAL22V10-5C HIGH-PERFORMANCE *IMPACT-XL*™ PROGRAMMABLE ARRAY LOGIC CIRCUIT

SRPS028A – MAY 1992 – REVISED OCTOBER 1993

## absolute maximum ratings over operating free-air temperature range (unless otherwise noted)

Supply voltage, $V_{CC}$ (see Note 1)	7 V
Input voltage range (see Note 1)	-1.2 V to $V_{CC} + 0.5$ V
Voltage range applied to disabled output (see Note 1)	-0.5 V to $V_{CC} + 0.5$ V
Operating free-air temperature range	0°C to 75°C
Storage temperature range	-65°C to 150°C

NOTE 1: These ratings apply except for programming pins during a programming cycle or during a preload cycle.

## recommended operating conditions

		MIN	NOM	MAX	UNIT
$V_{CC}$	Supply voltage	4.75	5	5.25	V
$V_{IH}$	High-level input voltage (see Note 2)	2		5.5	V
$V_{IL}$	Low-level input voltage (see Note 2)			0.8	V
$I_{OH}$	High-level output current			-3.2	mA
$I_{OL}$	Low-level output current			16	mA
$t_w$	Pulse duration	Clock high or low	3.5		ns
		Asynchronous reset high or low	5		
$t_{su}$	Setup time before clock $\uparrow$	Input	4.5		ns
		Feedback	4.5		
		Synchronous preset (active)	7		
		Synchronous preset (inactive)	7		
		Asynchronous reset (inactive)	6		
$t_h$	Hold time, input, set, or feedback after clock $\uparrow$	0			ns
$T_A$	Operating free-air temperature	0		75	°C

NOTE 2: These are absolute voltage levels with respect to the ground terminal of the device and includes all overshoots due to system and/or tester noise. Testing these parameters should not be attempted without suitable equipment.





# TIBPAL22V10-5C

## HIGH-PERFORMANCE *IMPACT-XL*<sup>™</sup> PROGRAMMABLE ARRAY LOGIC CIRCUIT

SRPS028A – MAY 1992 – REVISED OCTOBER 1993

### electrical characteristics over recommended operating free-air temperature range

PARAMETER		TEST CONDITIONS		MIN	TYP†	MAX	UNIT
V <sub>IK</sub>		V <sub>CC</sub> = 4.75 V,	I <sub>I</sub> = -18 mA			-1.2	V
V <sub>OH</sub>		V <sub>CC</sub> = 4.75 V,	I <sub>OH</sub> = -3.2 mA	2.4			V
V <sub>OL</sub>		V <sub>CC</sub> = 4.75 V,	I <sub>OL</sub> = 16 mA		0.35	0.5	V
I <sub>OZH</sub> ‡		V <sub>CC</sub> = 5.25 V,	V <sub>O</sub> = 2.7 V			0.1	mA
I <sub>OZL</sub> ‡		V <sub>CC</sub> = 5.25 V,	V <sub>O</sub> = 0.4 V			-0.1	mA
I <sub>I</sub>		V <sub>CC</sub> = 5.25 V,	V <sub>I</sub> = 5.5 V			1	mA
I <sub>IH</sub> ‡		V <sub>CC</sub> = 5.25 V,	V <sub>I</sub> = 2.7 V			25	μA
I <sub>IL</sub>	CLK	V <sub>CC</sub> = 5.25 V,	V <sub>I</sub> = 0.4 V			-0.3	mA
	All others					-0.1	
I <sub>OS</sub> §		V <sub>CC</sub> = 5.25 V,	V <sub>O</sub> = 0.5 V	-30		-130	mA
I <sub>CC</sub>		V <sub>CC</sub> = 5.25 V,	V <sub>I</sub> = GND,      Outputs open			210	mA
C <sub>i</sub>	I	f = 1 MHz,	V <sub>I</sub> = 2 V			7	pF
	CLK					8	
C <sub>o</sub>		f = 1 MHz,	V <sub>O</sub> = 2 V			10	pF

† All typical values are at V<sub>CC</sub> = 5 V, T<sub>A</sub> = 25°C.

‡ I/O leakage is the worst case of I<sub>OZL</sub> and I<sub>IL</sub> or I<sub>OZH</sub> and I<sub>IH</sub>, respectively.

§ Not more than one output should be shorted at a time, and the duration of the short circuit should not exceed one second. V<sub>O</sub> is set at 0.5 V to avoid test problems caused by test equipment ground degradation.

### switching characteristics over recommended ranges of supply voltage and operating free-air temperature (unless otherwise noted)

PARAMETER	FROM (INPUT)	TO (OUTPUT)	TEST CONDITIONS	MIN	MAX	UNIT
f <sub>max</sub> ¶	Without feedback		R1 = 300 Ω, R2 = 300 Ω, See Figure 4	143		MHz
	With internal feedback (counter configuration)			133		
	With external feedback			117		
t <sub>pd</sub>	I, I/O	I/O		1	5	ns
t <sub>pd</sub>	I, I/O (reset)	Q			10	ns
t <sub>pd</sub>	CLK	Q			0.5	4
t <sub>pd</sub> #	CLK	Feedback			3	ns
t <sub>en</sub>	I, I/O	I/O, Q			6.5	ns
t <sub>dis</sub>	I, I/O	I/O, Q			6	ns

$$¶ f_{\max} (\text{without feedback}) = \frac{1}{t_{w(\text{low})} + t_{w(\text{high})}}$$

$$f_{\max} (\text{with internal feedback}) = \frac{1}{t_{\text{su}} + t_{\text{pd}}(\text{CLK to feedback})}$$

$$f_{\max} (\text{with external feedback}) = \frac{1}{t_{\text{su}} + t_{\text{pd}}(\text{CLK to Q})}$$

# This parameter is calculated from the measured f<sub>max</sub> with internal feedback in the counter configuration.



# TIBPAL22V10-5C HIGH-PERFORMANCE *IMPACT-XL*™ PROGRAMMABLE ARRAY LOGIC CIRCUIT

SRPS028A – MAY 1992 – REVISED OCTOBER 1993

## preload procedure for registered outputs (see Note 3)

The output registers can be preloaded to any desired state during device testing. This permits any state to be tested without having to step through the entire state-machine sequence. Each register is preloaded individually by following the steps given below:

- Step 1. With  $V_{CC}$  at 5 V and pin 1 at  $V_{IL}$ , raise pin 14 to  $V_{IHH}$ .
- Step 2. Apply either  $V_{IL}$  or  $V_{IH}$  to the output corresponding to the register to be preloaded.
- Step 3. Pulse pin 1, clocking in preload data.
- Step 4. Remove output voltage, then lower pin 14 to  $V_{IL}$ . Preload can be verified by observing the voltage level at the output pin.

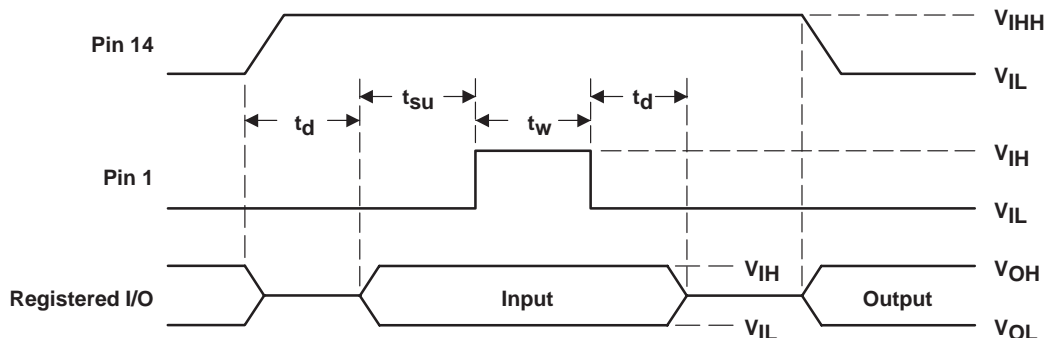
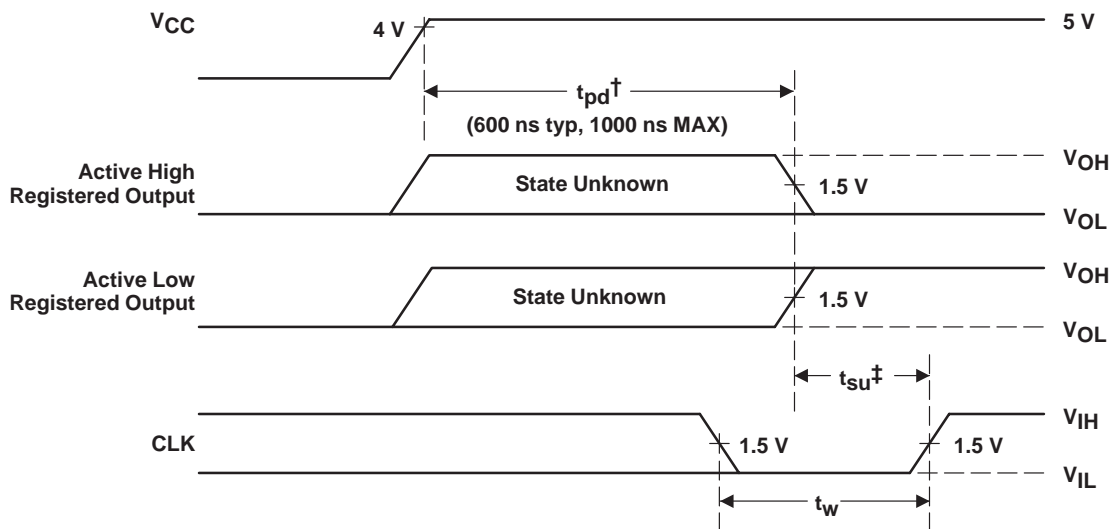

Figure 2. Preload Waveforms

NOTE 3:  $t_d = t_{su} = t_w = 100$  ns to 1000 ns.  $V_{IHH} = 10.25$  V to 10.75 V.

### power-up reset

Following power up, all registers are reset to zero. The output level depends on the polarity selected during programming. This feature provides extra flexibility to the system designer and is especially valuable in simplifying state-machine initialization. To ensure a valid power-up reset, it is important that the rise of  $V_{CC}$  be monotonic. Following power-up reset, a low-to-high clock transition must not occur until all applicable input and feedback setup times are met.



† This is the power-up reset time and applies to registered outputs only. The values shown are from characterization data.

‡ This is the setup time for input or feedback.

**Figure 3. Power-Up Reset Waveforms**

### programming information

Texas Instruments programmable logic devices can be programmed using widely available software and inexpensive device programmers.

Complete programming specifications, algorithms, and the latest information on hardware, software, and firmware are available upon request. Information on programmers capable of programming Texas Instruments programmable logic is also available, upon request, from the nearest TI field sales office, local authorized TI distributor, or by calling Texas Instruments at (214) 997-5666.

# TIBPAL22V10-5C HIGH-PERFORMANCE *IMPACT-XL*™ PROGRAMMABLE ARRAY LOGIC CIRCUIT

SRPS028A – MAY 1992 – REVISED OCTOBER 1993

## PARAMETER MEASUREMENT INFORMATION

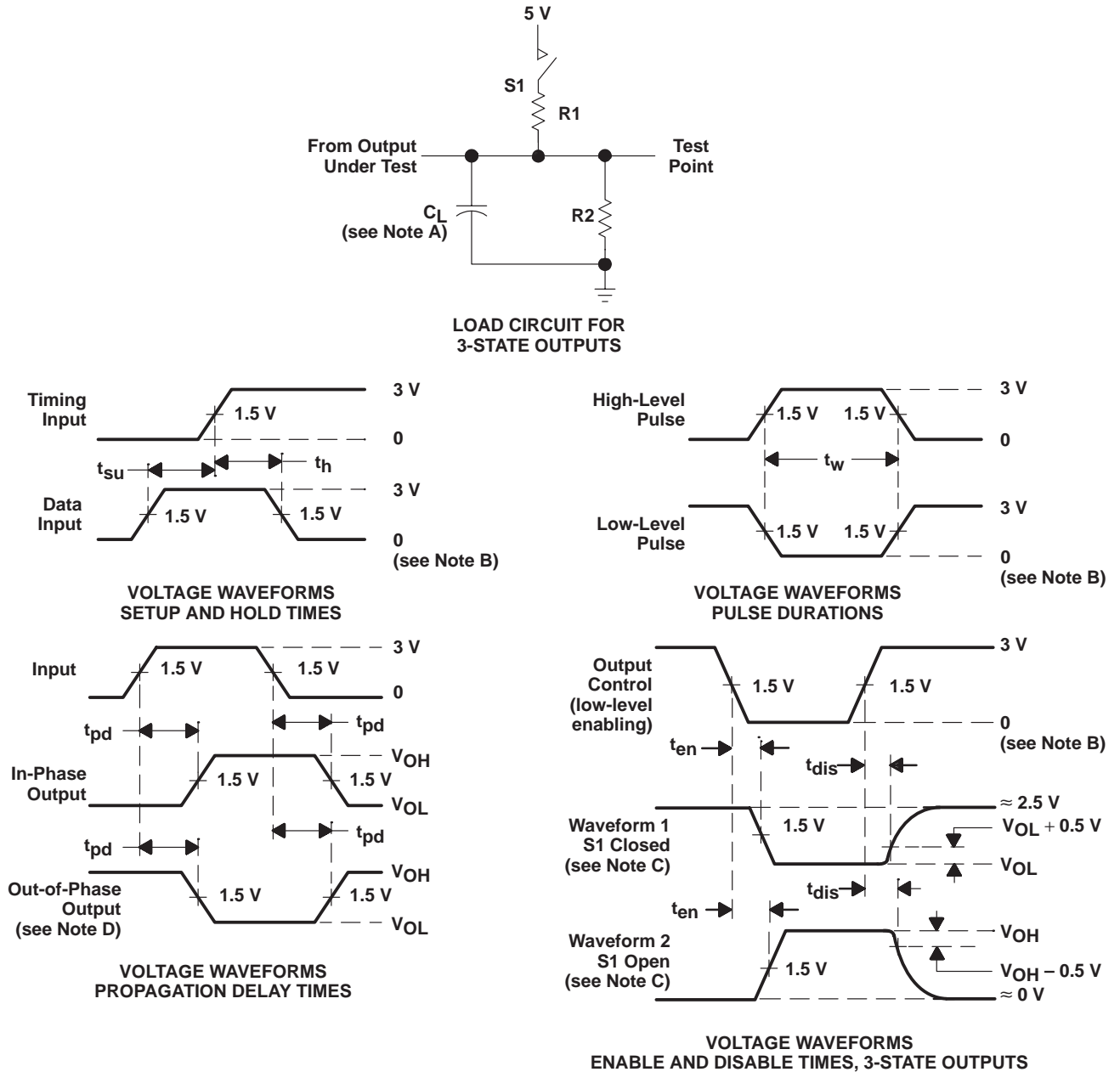

- NOTES: A.  $C_L$  includes probe and jig capacitance and is 50 pF for  $t_{pd}$  and  $t_{en}$ , 5 pF for  $t_{dis}$ .
- B. All input pulses have the following characteristics:  $PRR \leq 1$  MHz,  $t_r = t_f = 2$  ns, duty cycle = 50%.
- C. Waveform 1 is for an output with internal conditions such that the output is low except when disabled by the output control. Waveform 2 is for an output with internal conditions such that the output is high except when disabled by the output control.
- D. When measuring propagation delay times of 3-state outputs, switch S1 is closed.
- E. Equivalent loads may be used for testing.

Figure 4. Load Circuit and Voltage Waveforms

TYPICAL CHARACTERISTICS

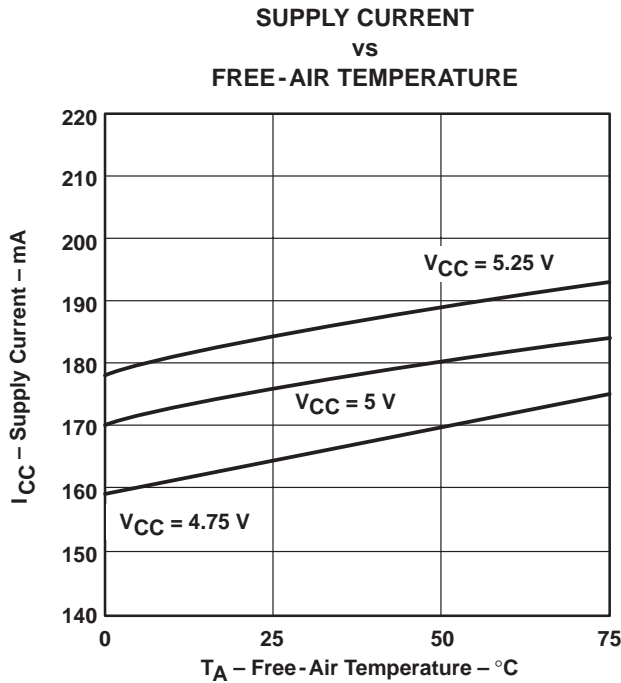

Figure 5

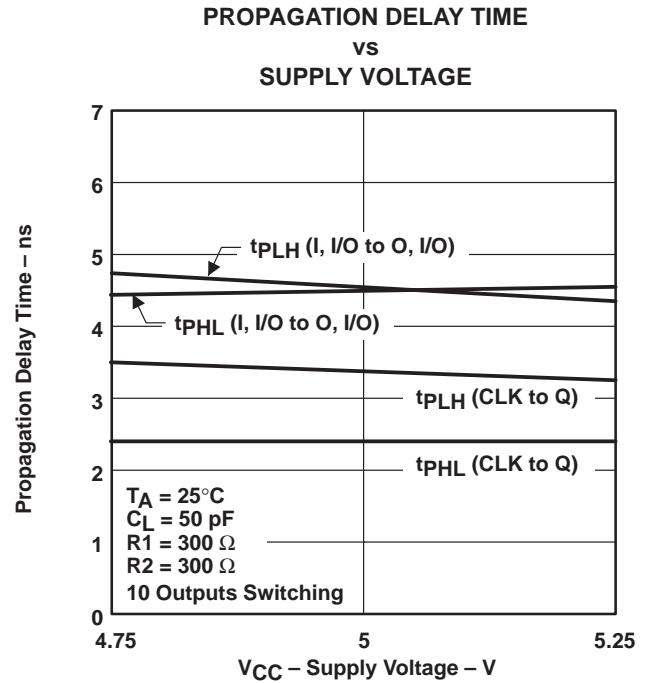

Figure 6

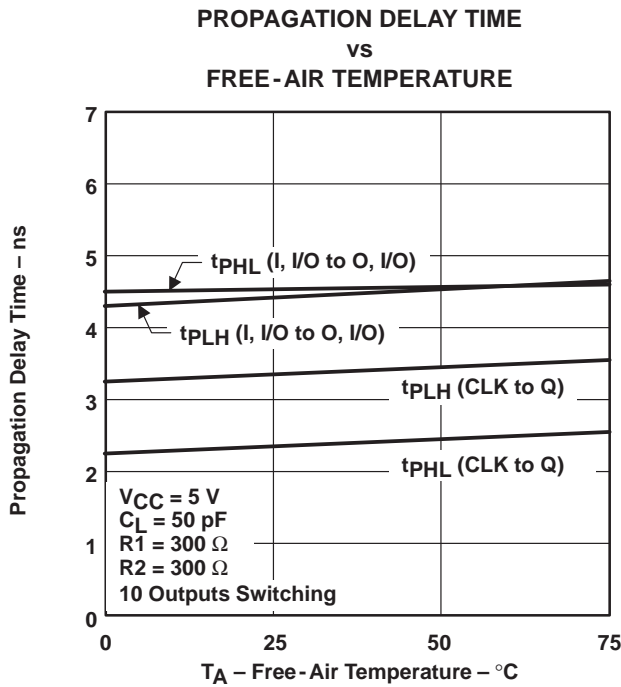

Figure 7

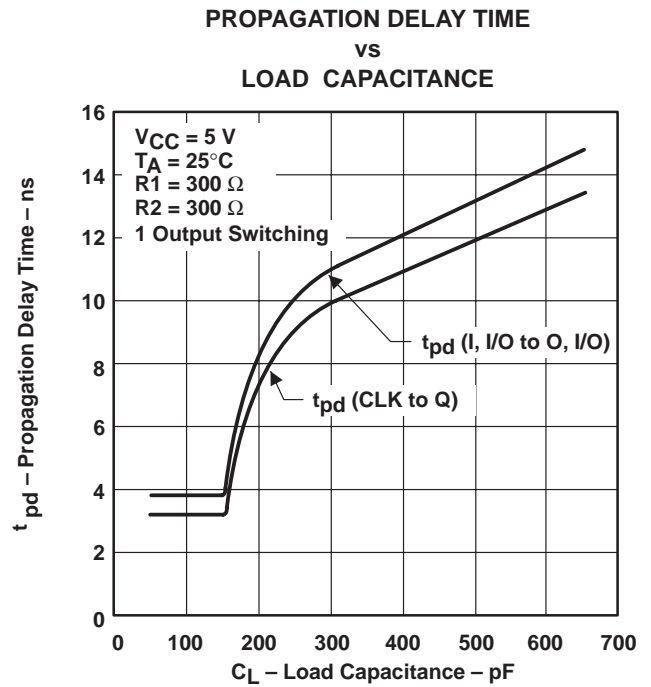

Figure 8

TYPICAL CHARACTERISTICS

WORST-CASE PROPAGATION DELAY TIME  
 vs  
 NUMBER OF OUTPUTS SWITCHING

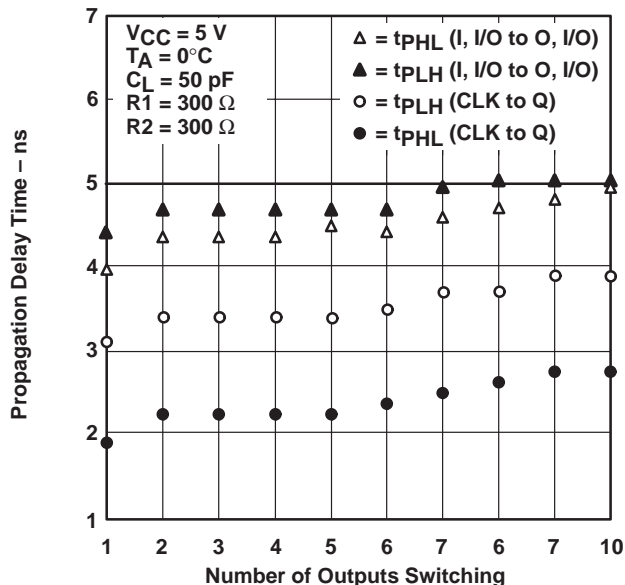

Figure 9

POWER DISSIPATION  
 vs  
 FREQUENCY  
 10-BIT COUNTER MODE

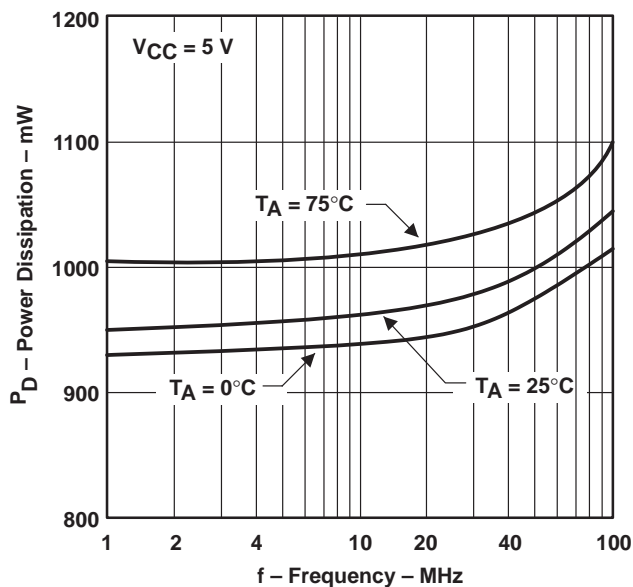

Figure 10

# TI Worldwide Sales Offices

**ALABAMA: Huntsville:** 4960 Corporate Drive, Suite 150, Huntsville, AL 35805, (205) 837-7530.

**ARIZONA: Phoenix:** 8825 N. 23rd Avenue, Suite 100, Phoenix, AZ 85021, (602) 995-1007.

**CALIFORNIA: Irvine:** 1920 Main Street, Suite 900, Irvine, CA 92714, (714) 660-1200;

**San Diego:** 5625 Ruffin Road, Suite 100, San Diego, CA 92123, (619) 278-9600;

**Santa Clara:** 5353 Betsy Ross Drive, Santa Clara, CA 95054, (408) 980-9000;

**Woodland Hills:** 21550 Oxnard Street, Suite 700, Woodland Hills, CA 91367, (818) 704-8100.

**COLORADO: Aurora:** 1400 S. Potomac Street, Suite 101, Aurora, CO 80012, (303) 368-8000.

**CONNECTICUT: Wallingford:** 9 Barnes Industrial Park So., Wallingford, CT 06492, (203) 269-0074.

**FLORIDA: Altamonte Springs:** 370 S. North Lake Boulevard, Suite 1008, Altamonte Springs, FL 32701, (407) 260-2116;

**Fort Lauderdale:** 2950 N.W. 62nd Street, Suite 100, Fort Lauderdale, FL 33309, (305) 973-8502; **Tampa:** 4803 George Road, Suite 390, Tampa, FL 33634-6234, (813) 885-7588.

**GEORGIA: Norcross:** 5515 Spalding Drive, Norcross, GA 30092-2560, (404) 662-7967.

**ILLINOIS: Arlington Heights:** 515 West Algonquin, Arlington Heights, IL 60005, (708) 640-6925.

**INDIANA: Carmel:** 550 Congressional Drive, Suite 100, Carmel, IN 46032, (317) 573-6400;

**Fort Wayne:** 103 Airport North Office Park, Fort Wayne, IN 46825, (219) 489-4697.

**KANSAS: Overland Park:** 7300 College Boulevard, Lighton Plaza, Suite 150, Overland Park, KS 66210, (913) 451-4511.

**MARYLAND: Columbia:** 8815 Centre Park Drive, Suite 100, Columbia, MD 21045, (410) 964-2003.

**MASSACHUSETTS: Waltham:** Bay Colony Corporate Center 950 Winter Street, Suite 2800, Waltham, MA 02154, (617) 895-9100.

**MICHIGAN: Farmington Hills:** 33737 W. 12 Mile Road, Farmington Hills, MI 48018, (313) 553-1581.

**MINNESOTA: Eden Prairie:** 11000 W. 78th Street, Suite 100, Eden Prairie, MN 55344, (612) 828-9300.

**MISSOURI: St. Louis:** 12412 Powerscourt Drive, Suite 125, St. Louis, MO 63131, (314) 821-8400.

**NEW JERSEY: Iselin:** Metropolitan Corporate Plaza, 485 Bldg E. U.S. 1 South, Iselin, NJ 08830, (908) 750-1050.

**NEW MEXICO: Albuquerque:** 2709 J. Pan American Freeway, NE, Albuquerque, NM 87101, (505) 345-2555.

**NEW YORK: East Syracuse:** 6365 Collamer Drive, East Syracuse, NY 13057, (315) 463-9291;

**Fishkill:** 300 Westage Business Center, Suite 140, Fishkill, NY 12524, (914) 897-2900;

**Melville:** 48 South Service Road, Suite 100, Melville, NY 11747, (516) 454-6601;

**Pittsford:** 2851 Clover Street, Pittsford, NY 14534, (716) 385-6770.

**NORTH CAROLINA: Charlotte:** 8 Woodlawn Green, Suite 100, Charlotte, NC 28217, (704) 527-0930;

**Raleigh:** 2809 Highwoods Boulevard, Suite 100, Raleigh, NC 27625, (919) 876-2725.

**OHIO: Beachwood:** 23775 Commerce Park Road, Beachwood, OH 44122-5875, (216) 765-7258;

**Beavercreek:** 4200 Colonel Glenn Highway, Suite 600, Beavercreek, OH 45431, (513) 427-6200.

**OREGON: Beaverton:** 6700 S.W. 105th Street, Suite 110, Beaverton, OR 97005, (503) 643-6758.

**PENNSYLVANIA: Blue Bell:** 670 Sentry Parkway, Suite 200, Blue Bell, PA 19422, (215) 825-9500.

**PUERTO RICO: Hato Rey:** 615 Mercantil Plaza Building, Suite 505, Hato Rey, PR 00919, (809) 753-8700.

**TEXAS: Austin:** 12501 Research Boulevard, Austin, TX 78759, (512) 250-6769;

**Dallas:** 7839 Churchill Way, Dallas, TX 75251, (214) 917-1264;

**Houston:** 9301 Southwest Freeway, Commerce Park, Suite 600, Houston, TX 77074, (713) 778-6592;

**Midland:** FM 1788 & I-20, Midland, TX 79711-0448, (915) 561-7137.

**UTAH: Salt Lake City:** 2180 South 1300 East, Suite 335, Salt Lake City, UT 54106, (801) 466-8972.

**WISCONSIN: Waukesha:** 20825 Swenson Drive, Suite 900, Waukesha WI 53186, (414) 798-1001.

**CANADA: Nepean:** 301 Moodie Drive, Suite 102, Mallorn Centre, Nepean, Ontario, Canada K2H 9C4, (613) 726-1970;

**Richmond Hill:** 280 Centre Street East, Richmond Hill, Ontario, Canada L4C 1B1, (416) 884-9181;

**St. Laurent:** 9460 Trans Canada Highway, St. Laurent, Quebec, Canada H4S 1R7, (514) 335-8392.

**AUSTRALIA (& NEW ZEALAND):** Texas Instruments Australia Ltd., 6-10 Talavera Road, North Ryde (Sydney), New South Wales, Australia 2113, 2-878-9000; 14th Floor, 380 Street, Kilda Road, Melbourne, Victoria, Australia 3000, 3-696-1211.

**BELGIUM:** Texas Instruments Belgium S.A./N.V., Avenue Jules Bordetlaan 11, 1140 Brussels, Belgium, (02) 242 30 80.

**BRAZIL:** Texas Instruments Electronicos do Brasil Ltda., Av. Eng. Luiz Carlos Berrini 1461-110. andar, 04571, Sao Paulo, SP, Brazil, 11-535-5133.

**DENMARK:** Texas Instruments A/S, Borupvang 2D, DK-2750 Ballerup, Denmark, (44) 68 74 00.

**FINLAND:** Texas Instruments OY, Ahertajantie 3, P.O. Box 86, 02321 Espoo, Finland, (0) 802 6517.

**FRANCE:** Texas Instruments France, 8-10 Avenue Morane-Saulnier, B.P. 67, 78141 Velizy-Villacoublay Cedex, France, (1) 30 70 1003.

**GERMANY:** Texas Instruments Deutschland GmbH., Haggertystraße 1, 8050 Freising, (08161) 80-0; Kurfürstendamm 195-196, 1000 Berlin 15, (030) 8 82 73 65; Düsseldorf StraÙe 40, 6236 Eschborn 1, (06196) 80 70; Hollestraße 3, 4300 Essen 1, (0201) 23 66 40; Kirchhorster Straße 2, 3000 Hannover 51, (0511) 64 68-0; Maybachstraße II, 7302 Ostfildern 2 (Nellingen), (0711) 3003 257.

**HOLLAND:** Texas Instruments Holland B.V., Hogehilweg 19, Postbus 12995, 1100 AZ Amsterdam-Zuidoost, Holland, (020) 5602911.

**HONG KONG:** Texas Instruments Hong Kong Ltd., 8th Floor, World Shipping Centre, 7 Canton Road, Kowloon, Hong Kong, 737-0338.

**HUNGARY:** Texas Instruments Representation, Budaörsi ut.42, 1112 Budapest, Hungary, (1) 1 66 66 17.

**IRELAND:** Texas Instruments Ireland Ltd., 7/8 Harcourt Street, Dublin 2, Ireland, (01) 755233.

**ITALY:** Texas Instruments Italia S.p.A., Centro Direzionale Colleoni, Palazzo Perseo-Via Paracelso 12, 20041 Agrate Brianza (Mi), Italy, (039) 63221; Via Castello della Magliana, 38, 00148 Roma, Italy (06) 657 2651.

**JAPAN:** Texas Instruments Japan Ltd., Aoyama Fuji Building 3-6-12 Kita-Aoyama Minato-ku, Tokyo, Japan 107, 03-498-2111; MS Shibaura Building 9F, 4-13-23 Shibaura, Minato-ku, Tokyo, Japan 108, 03-769-8700; Nissho-wai Building 5F, 2-5-8 Imabashi, Chuou-ku, Osaka, Japan 541, 06-204-1881; Dai-ni Toyota Building Nishi-kan 7F, 4-10-27 Meieki, Nakamura-ku, Nagoya, Japan 450, 052-583-8691; Kanazawa Oyama-cho Daiichi Seimei Building 6F, 3-10 Oyama-cho, Kanazawa-shi, Ishikawa, Japan 920, 0762-23-5471; Matsumoto Showa Building 6F, 1-2-11 Fukushi, Matsumoto-shi, Nagano, Japan 390, 0263-33-1060; Daiichi Olympic Tachikawa Building 6F, 1-25-12, Akebono-cho, Tachikawa-shi, Tokyo, Japan 190, 0425-27-6760; Yokohama Business Park East Tower 10F, 134 Goudo-cho Hodogaya-ku, Yokohama-shi, Kanagawa, Japan 240, 045-338-1220; Nihon Seimei Kyoto Yasaka Building 5F, 843-2, Higashi-Shiohohji-cho, Higashi-iru, Nishinotoh-in, Shiohohji-dori, Shimogyo-ku, Kyoto, Japan 600, 075-341-7713; Sumitomo Seimei Kumagaya Bldg. 8F, 2-44 Yayoi, Kumagaya-shi, Saitama, Japan 360, 0485-22-2440; 2597-1, Aza Harudai, Oaza Yasaka, Kitaki-shi, Oita, Japan 873, 09786-3-3211.

**KOREA:** Texas Instruments Korea Ltd., 28th Floor, Trade Tower, 159-1, Samsung-Dong, Kangnam-ku Seoul, Korea, 2 551-2800.

**MALAYSIA:** Texas Instruments Malaysia, Sdn. Bhd., Asia Pacific, Lot 36.1 #Box 93, Menara Maybank, 100 Jalan Tun Perak, 50050 Kuala Lumpur, Malaysia, 3-230-6001.

**MEXICO:** Texas Instruments de Mexico S.A., de C.V., Alfonso Reyes 115, Col. Hipodromo Condesa, Mexico, D.F., 06170, 5-515-6081.

**NORWAY:** Texas Instruments Norge A/S, B.P. 106, Refstad (Sinsenveien 53), 0513 Oslo 5, Norway, (02) 155 090.

**PEOPLE'S REPUBLIC OF CHINA:** Texas Instruments China Inc., Beijing Representative Office, 7-05 CITIC Building, 19 Jianguomenwai Dajie, Beijing, China, 500-2255, Ext. 3750.

**PHILIPPINES:** Texas Instruments Asia Ltd., Philippines Branch, 14th Floor, Ba-Lepanto Building, 8747 Paseo de Roxas, 1226 Makati, Metro Manila, Philippines, 2-817-6031.

**PORTUGAL:** Texas Instruments Equipamento Electronico (Portugal) LDA, Ing. Frederico Ulricho, 2650 Moreira Da Maia, 4470 Maia, Portugal (2) 948 1003.

**SINGAPORE (& INDIA, INDONESIA, MALAYSIA, THAILAND):** Texas Instruments Singapore (PTE) Ltd., Asia Pacific, 101 Thomson Road, #23-01, United Square, Singapore 1130, 350-8100.

**SPAIN:** Texas Instruments España S.A., c/Gobelos 43, Urbanizacion La Florida, 28023, Madrid, Spain, (91) 372 8051; c/Diputacion, 279-3-5, 08007 Barcelona, Spain, (93) 317 91 80.

**SWEDEN:** Texas Instruments International Trade Corporation (Sverigefilialen), Box 30, S-164 93 Kista, Sweden, (08) 752 58 00.

**SWITZERLAND:** Texas Instruments Switzerland AG, Riedstrasse 6, CH-8953 Dietikon, Switzerland, (01) 744 2811.

**TAIWAN:** Texas Instruments Taiwan Limited, Taipei Branch, 10th Floor Bank Tower, 205 Tung Hwa N. Road, Taipei, Taiwan, 10592 Republic of China, (02) 713-9311.

**UNITED KINGDOM:** Texas Instruments Ltd., Manton Lane, Bedford, England, MK41 7PA, (0234) 270 111.

## TI Authorized North American Distributors

Alliance Electronics, Inc. (military product only)  
Almac/Arrow

Anthem Electronics

Arrow/Schweber

Future Electronics (Canada)

GRS Electronics Co., Inc. \*

Hall-Mark Electronics

Marshall Industries

Newark Electronics \*

Wyle Laboratories

Zeus Components

Rochester Electronics, Inc. (obsolete product only)

\*Not authorized for TI military products



B0293

# TI North American Sales Offices

**ALABAMA:** Huntsville: (205) 837-7530  
**ARIZONA:** Phoenix: (602) 995-1007  
**CALIFORNIA:** Irvine: (714) 660-1200  
 San Diego: (619) 278-9600  
 Santa Clara: (408) 980-9000  
 Woodland Hills: (818) 704-8100  
**COLORADO:** Aurora: (303) 368-8000  
**CONNECTICUT:** Wallingford: (203) 269-0074  
**FLORIDA:** Altamonte Springs: (407) 260-2116  
 Fort Lauderdale: (305) 973-8502  
 Tampa: (813) 885-7588  
**GEORGIA:** Norcross: (404) 662-7967  
**ILLINOIS:** Arlington Heights: (708) 640-3000  
**INDIANA:** Carmel: (317) 573-6400  
 Fort Wayne: (219) 489-4697  
**KANSAS:** Overland Park: (913) 451-4511  
**MARYLAND:** Columbia: (410) 964-2003  
**MASSACHUSETTS:** Waltham: (617) 895-9100  
**MICHIGAN:** Farmington Hills: (313) 553-1581  
**MINNESOTA:** Eden Prairie: (612) 828-9300  
**MISSOURI:** St. Louis: (314) 821-8400  
**NEW JERSEY:** Iselin: (908) 750-1050  
**NEW MEXICO:** Albuquerque: (505) 345-2555  
**NEW YORK:** East Syracuse: (315) 463-9291  
 Fishkill: (914) 897-2900  
 Melville: (516) 454-6600  
 Pittsford: (716) 385-6770  
**NORTH CAROLINA:** Charlotte: (704) 527-0930  
 Raleigh: (919) 876-2725  
**OHIO:** Beachwood: (216) 765-7258  
 Beavercreek: (513) 427-6200  
**OREGON:** Beaverton: (503) 643-6758  
**PENNSYLVANIA:** Blue Bell: (215) 825-9500  
**PUERTO RICO:** Hato Rey: (809) 753-8700  
**TEXAS:** Austin: (512) 250-6769  
 Dallas: (214) 917-1264  
 Houston: (713) 778-6592  
 Midland: (915) 561-7137  
**UTAH:** Salt Lake City: (801) 466-8972  
**WISCONSIN:** Waukesha: (414) 798-1001  
**CANADA:** Nepean: (613) 726-1970  
 Richmond Hill: (416) 884-9181  
 St. Laurent: (514) 335-8392

# TI Regional Technology Centers

**CALIFORNIA:** Irvine: (714) 660-8140  
 Santa Clara: (408) 748-2222  
**GEORGIA:** Norcross: (404) 662-7945  
**ILLINOIS:** Arlington Heights: (708) 640-2909  
**INDIANA:** Indianapolis: (317) 573-6400  
**MASSACHUSETTS:** Waltham: (617) 895-9196  
**MEXICO:** Mexico City: 491-70834  
**MINNESOTA:** Minneapolis: (612) 828-9300  
**TEXAS:** Dallas: (214) 917-3881  
**CANADA:** Nepean: (613) 726-1970

## Customer Response Center

**TOLL FREE:** (800) 336-5236  
**OUTSIDE USA:** (214) 995-6611  
 (8:00 a.m. – 5:00 p.m. CST)

# TI Authorized North American Distributors

Alliance Electronics, Inc. (military product only)  
 Almac/Arrow  
 Anthem Electronics  
 Arrow/Schweber  
 Future Electronics (Canada)  
 GRS Electronics Co., Inc.\*  
 Hall-Mark Electronics  
 Marshall Industries  
 Newark Electronics\*  
 Rochester Electronics, Inc. (obsolete product only)  
 Wyle Laboratories  
 Zeus Components

\*Not authorized for TI military products

# TI Distributors

**ALABAMA:** Arrow/Schweber (205) 837-6955; Hall-Mark (205) 837-8700; Marshall (205) 881-9235.  
**ARIZONA:** Anthem (602) 966-6600; Arrow/Schweber (602) 437-0750; Hall-Mark (602) 431-0030; Marshall (602) 496-0290; Wyle (602) 437-2088.  
**CALIFORNIA:** Los Angeles/Orange County: Anthem (818) 775-1333, (714) 768-4444; Arrow/Schweber (818) 380-9686, (714) 587-0404; Hall-Mark (818) 773-4500, (714) 727-6000; Marshall (818) 878-7000, (714) 458-5301; Wyle (818) 880-9000, (714) 863-9953; Zeus (714) 921-9000, (818) 889-3838;  
 Sacramento: Anthem (916) 624-9744; Hall-Mark (916) 624-9781; Marshall (916) 635-9700; Wyle (916) 638-5282;  
 San Diego: Anthem (619) 453-9005; Arrow/Schweber (619) 565-4800; Hall-Mark (619) 268-1201; Marshall (619) 627-4140; Wyle (619) 565-9171; Zeus (619) 277-9681;  
 San Francisco Bay Area: Anthem (408) 453-1200; Arrow/Schweber (408) 441-9700, (510) 490-9477; Hall-Mark (408) 432-4000; Marshall (408) 942-4600; Wyle (408) 727-2500; Zeus (408) 629-4789.  
**COLORADO:** Anthem (303) 790-4500; Arrow/Schweber (303) 799-0258; Hall-Mark (303) 790-1662; Marshall (303) 451-8383; Wyle (303) 457-9953.  
**CONNECTICUT:** Anthem (203) 575-1575; Arrow/Schweber (203) 265-7741; Hall-Mark (203) 271-2844; Marshall (203) 265-3822.  
**FLORIDA:** Fort Lauderdale: Arrow/Schweber (305) 429-8200; Hall-Mark (305) 971-9280; Marshall (305) 977-4880;  
 Orlando: Arrow/Schweber (407) 333-9300; Hall-Mark (407) 830-5855; Marshall (407) 767-8585; Zeus (407) 788-9100;  
 Tampa: Hall-Mark (813) 541-7440; Marshall (813) 573-1399.  
**GEORGIA:** Arrow/Schweber (404) 497-1300; Hall-Mark (404) 623-4400; Marshall (404) 923-5750.  
**ILLINOIS:** Anthem (708) 884-0200; Arrow/Schweber (708) 250-0500; Hall-Mark (708) 860-3800; Marshall (708) 490-0155; Newark (312) 784-5100.  
**INDIANA:** Arrow/Schweber (317) 299-2071; Hall-Mark (317) 872-8875; Marshall (317) 297-0483.  
**IOWA:** Arrow/Schweber (319) 395-7230.  
**KANSAS:** Arrow/Schweber (913) 541-9542; Hall-Mark (913) 888-4747; Marshall (913) 492-3121.  
**MARYLAND:** Anthem (301) 995-6640; Arrow/Schweber (301) 596-7800; Hall-Mark (301) 988-9800; Marshall (301) 622-1118; Zeus (301) 997-1118.  
**MASSACHUSETTS:** Anthem (508) 657-5170; Arrow/Schweber (508) 658-0900; Hall-Mark (508) 667-0902; Marshall (508) 658-0810; Wyle (617) 272-7300; Zeus (617) 246-8200.

**MICHIGAN:** Detroit: Arrow/Schweber (313) 416-5800; Hall-Mark (313) 416-5800; Marshall (313) 525-5850; Newark (313) 967-0600.  
**MINNESOTA:** Anthem (612) 944-5454; Arrow/Schweber (612) 941-5280; Hall-Mark (612) 881-2600; Marshall (612) 559-2211.  
**MISSOURI:** Arrow/Schweber (314) 567-6888; Hall-Mark (314) 291-5350; Marshall (314) 291-4650.  
**NEW JERSEY:** Anthem (201) 227-7960; Arrow/Schweber (201) 227-7880, (609) 596-8000; Hall-Mark (201) 515-3000, (609) 235-1900; Marshall (201) 882-0320, (609) 234-9100.  
**NEW MEXICO:** Alliance (505) 292-3360.  
**NEW YORK:** Long Island: Anthem (516) 864-6600; Arrow/Schweber (516) 231-1000; Hall-Mark (516) 737-0600; Marshall (516) 273-2424; Zeus (914) 937-7400;  
 Rochester: Arrow/Schweber (716) 427-0300; Hall-Mark (716) 425-3300; Marshall (716) 235-7620;  
 Syracuse: Marshall (607) 785-2345.  
**NORTH CAROLINA:** Arrow/Schweber (919) 876-3132; Hall-Mark (919) 872-0712; Marshall (919) 878-9882.  
**OHIO:** Cleveland: Arrow/Schweber (216) 248-3990; Hall-Mark (216) 349-4632; Marshall (216) 248-1788;  
 Columbus: Hall-Mark (614) 888-3313;  
 Dayton: Arrow/Schweber (513) 435-5563; Marshall (513) 898-4480; Zeus (513) 293-6162.  
**OKLAHOMA:** Arrow/Schweber (918) 252-7537; Hall-Mark (918) 254-6110.  
**OREGON:** Almac/Arrow (503) 629-8090; Anthem (503) 643-1114; Marshall (503) 644-5050; Wyle (503) 643-7900.  
**PENNSYLVANIA:** Anthem (215) 443-5150; Arrow/Schweber (215) 928-1800; GRS (215) 922-7037; (609) 964-8560; Marshall (412) 788-0441.  
**TEXAS:** Austin: Arrow/Schweber (512) 835-4180; Hall-Mark (512) 258-8848; Marshall (512) 837-1991; Wyle (512) 345-8853;  
 Dallas: Anthem (214) 238-7100; Arrow/Schweber (214) 380-6464; Hall-Mark (214) 553-4300; Marshall (214) 233-5200; Wyle (214) 235-9953; Zeus (214) 783-7010;  
 Houston: Arrow/Schweber (713) 530-4700; Hall-Mark (713) 781-6100; Marshall (713) 467-1666; Wyle (713) 879-9953.  
**UTAH:** Anthem (801) 973-8555; Arrow/Schweber (801) 973-6913; Hall-Mark (801) 269-0416; Marshall (801) 973-2288; Wyle (801) 974-9953.  
**WASHINGTON:** Almac/Arrow (206) 643-9992; Anthem (206) 483-1700; Marshall (206) 486-5747; Wyle (206) 881-1150.  
**WISCONSIN:** Arrow/Schweber (414) 792-0150; Hall-Mark (414) 797-7844; Marshall (414) 797-8400.  
**CANADA:** Calgary: Future (403) 235-5325;  
 Edmonton: Future (403) 438-2858;  
 Montreal: Arrow/Schweber (514) 421-7411; Future (514) 694-7710; Marshall (514) 694-8142;  
 Ottawa: Arrow/Schweber (613) 226-6903; Future (613) 820-8313;  
 Quebec: Future (418) 897-6666;  
 Toronto: Arrow/Schweber (416) 670-7769; Future (416) 612-9200; Marshall (416) 458-8046;  
 Vancouver: Arrow/Schweber (604) 421-2333; Future (604) 294-1166.

## TI Die Processors

Chip Supply (407) 298-7100  
 Elmo Semiconductor (818) 768-7400  
 Minco Technology Labs (512) 834-2022



D0293



## IMPORTANT NOTICE

Texas Instruments and its subsidiaries (TI) reserve the right to make changes to their products or to discontinue any product or service without notice, and advise customers to obtain the latest version of relevant information to verify, before placing orders, that information being relied on is current and complete. All products are sold subject to the terms and conditions of sale supplied at the time of order acknowledgement, including those pertaining to warranty, patent infringement, and limitation of liability.

TI warrants performance of its semiconductor products to the specifications applicable at the time of sale in accordance with TI's standard warranty. Testing and other quality control techniques are utilized to the extent TI deems necessary to support this warranty. Specific testing of all parameters of each device is not necessarily performed, except those mandated by government requirements.

CERTAIN APPLICATIONS USING SEMICONDUCTOR PRODUCTS MAY INVOLVE POTENTIAL RISKS OF DEATH, PERSONAL INJURY, OR SEVERE PROPERTY OR ENVIRONMENTAL DAMAGE ("CRITICAL APPLICATIONS"). TI SEMICONDUCTOR PRODUCTS ARE NOT DESIGNED, AUTHORIZED, OR WARRANTED TO BE SUITABLE FOR USE IN LIFE-SUPPORT DEVICES OR SYSTEMS OR OTHER CRITICAL APPLICATIONS. INCLUSION OF TI PRODUCTS IN SUCH APPLICATIONS IS UNDERSTOOD TO BE FULLY AT THE CUSTOMER'S RISK.

In order to minimize risks associated with the customer's applications, adequate design and operating safeguards must be provided by the customer to minimize inherent or procedural hazards.

TI assumes no liability for applications assistance or customer product design. TI does not warrant or represent that any license, either express or implied, is granted under any patent right, copyright, mask work right, or other intellectual property right of TI covering or relating to any combination, machine, or process in which such semiconductor products or services might be or are used. TI's publication of information regarding any third party's products or services does not constitute TI's approval, warranty or endorsement thereof.