

DFA Series



- U Channel and Hotswap DC-DC Converter
- -48 VDC Input
- DC Input version of MFA350 AC-DC Converter
- -10 °C to + 70 °C Operation
- Power Fail and DC OK Signals
- High Power Density up to 11.1 W / in³
- 5 V Standby and 12 V Fan Supply Outputs

Specification

Input

Input Voltage Range	<ul style="list-style-type: none"> • 48 VDC nominal (36 - 75 VDC). Can be configured as -48 VDC input
Input Current	<ul style="list-style-type: none"> • 9.2 A typical, 12.5 A max
Input Reverse Voltage Protection	<ul style="list-style-type: none"> • Continuous protection with automatic recovery
Undervoltage Lockout Protection	<ul style="list-style-type: none"> • 32 - 36VDC

Output

Output Voltage	<ul style="list-style-type: none"> • See table
Output Voltage Trim	<ul style="list-style-type: none"> • ±10% via potentiometer
Minimum Load	<ul style="list-style-type: none"> • No minimum load required.
Line Regulation	<ul style="list-style-type: none"> • ±0.5% of nominal with input variation of 36-75V DC
Load Regulation	<ul style="list-style-type: none"> • ±1% of nominal with load variation 0-100%
Setpoint Accuracy	<ul style="list-style-type: none"> • ±1% of nominal with 48 VDC input and 50% load
Turn-on Time	<ul style="list-style-type: none"> • 1 s typical from application of DC input
Transient Response	<ul style="list-style-type: none"> • <4% deviation with a 50-75-50% load change at 1 A/μs. Output returns to within 1% in less than 500 μs
Ripple & Noise	<ul style="list-style-type: none"> • 1% max pk-pk 20 MHz bandwidth, 0.1 μF capacitor connected across measurement points
Overvoltage Protection	<ul style="list-style-type: none"> • 115-140% of nominal, recycle input DC to reset
Overcurrent Protection	<ul style="list-style-type: none"> • 105-115% of max current
Short Circuit Protection	<ul style="list-style-type: none"> • Continuous protection, trip and restart (Hiccup mode) characteristic
Temperature Coefficient	<ul style="list-style-type: none"> • 0.02%/°C (after 20 minute warm up)

General

Efficiency	<ul style="list-style-type: none"> • 85% typical
Isolation Voltage	<ul style="list-style-type: none"> • 1500 VDC Input to Output, 1000 VDC Input to Ground, 500 VDC Output to Ground.
Switching Frequency	<ul style="list-style-type: none"> • 370 kHz typical
Power Density	<ul style="list-style-type: none"> • 11.1 W/in³

Environmental

Operating Temperature	<ul style="list-style-type: none"> • -10 °C to +50 °C with full load, derate linearly to 50% load at 70 °C forced cooled.
Cooling	<ul style="list-style-type: none"> • >20 CFM forced airflow required -H versions have integrated fan
Operating Humidity	<ul style="list-style-type: none"> • 0 to 95% RH non condensing.
Storage Temperature	<ul style="list-style-type: none"> • -40 °C to +80 °C.
Storage Humidity	<ul style="list-style-type: none"> • 0 to 95% RH non condensing.
Operating Altitude	<ul style="list-style-type: none"> • 3000m.
Shock	<ul style="list-style-type: none"> • ±3 shocks in each axis (total 18 shocks) 30 g 11ms (half sine).
Vibration	<ul style="list-style-type: none"> • 2 g, 10 - 500Hz 10 sweeps.

EMC & Safety

Emissions	<ul style="list-style-type: none"> • Compliant with EN61204-3 2000, EN55022 class A conducted & radiated
EFT/Burst	<ul style="list-style-type: none"> • Compliant with EN61000-4-4 level 1 Perf Criteria A
Surge	<ul style="list-style-type: none"> • EN61000-4-5 level 1 Perf Criteria A,
Conducted Immunity	<ul style="list-style-type: none"> • Compliant with EN61000-4-6 level 2 Perf Criteria A
Safety Approvals	<ul style="list-style-type: none"> • UL60950-1 (2003), CE Marked to LVD

Output Voltage V1	Max Output Current V1	Fan Output V2	Standby Supply V3	Max Power 20 CFM Airflow	Model Number
12 VDC	29.0 A	12 V/1 A	5 V/1 A	365 W	DFA35048S12
24 VDC	14.5 A	12 V/1 A	5 V/1 A	365 W	DFA35048S24

Mechanical Details (U Channel)

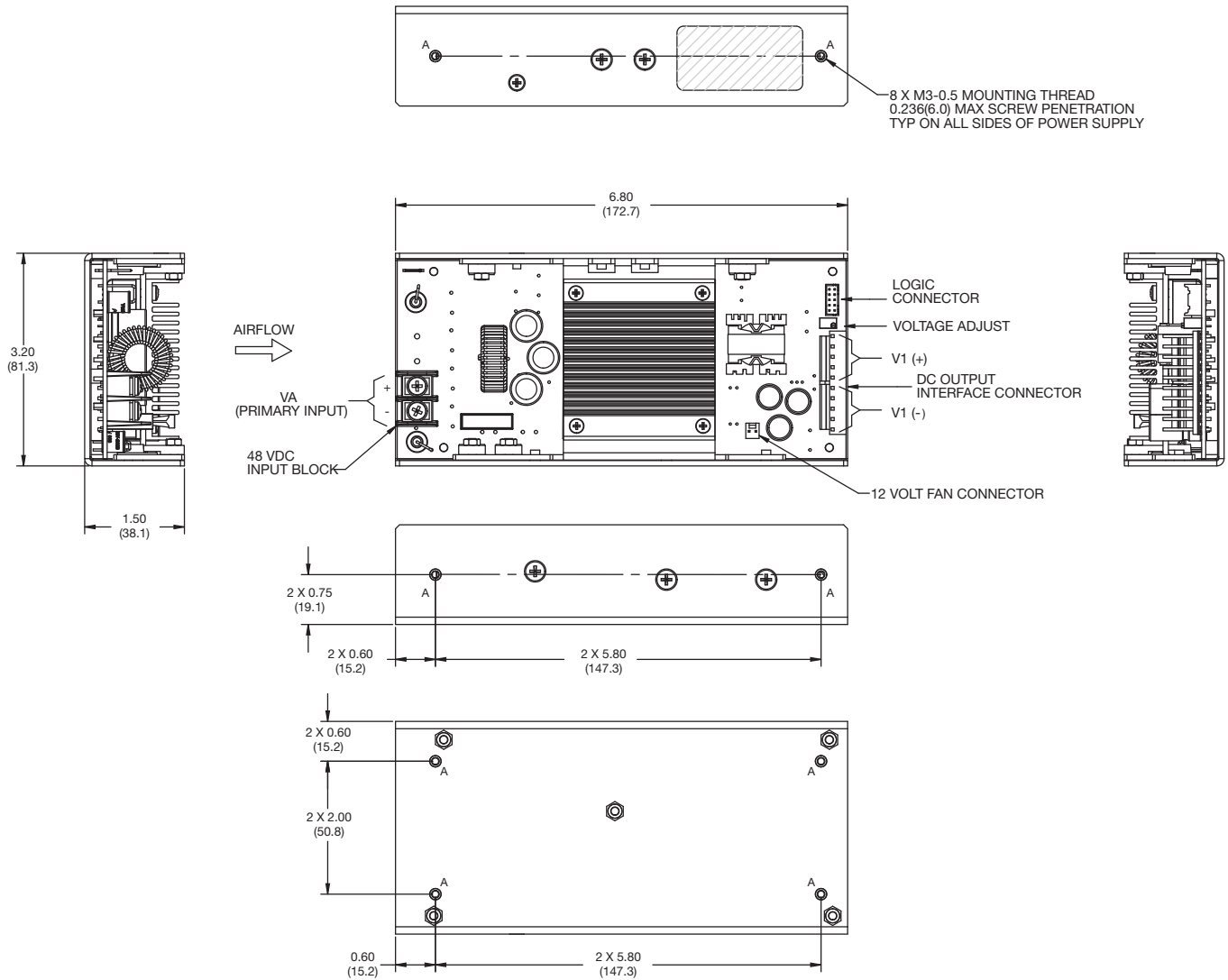

Logic Connector	
Pin	Function
1	DC IN OK
2	Inhibit / Enable
3	Not used
4	DC OK
5	Not used
6	+Sense
7	-Sense
8	Not used
9	5 V Standby
10	5 V Standby Return

Logic Connector: JST PN B10B-PHDSS(LF)(SN)
Mating Plug: JST PN PHDR-10VS
Contact, 26-22 AWG: JST PN SPHD-001T-P0.5

Output Voltage V1	Maximum Output Current	Standby Supply V3	Max Power	Model Number
12.0 VDC	29.0 A	5 V/1 A	365 W	DFA35048S12-H
24.0 VDC	14.5 A	5 V/1 A	365 W	DFA35048S24-H

Mechanical Details (-H Hotswap)

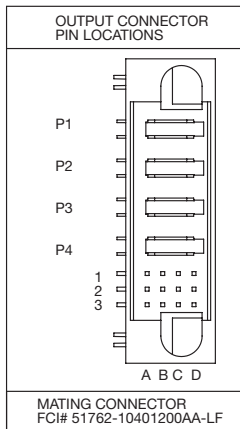
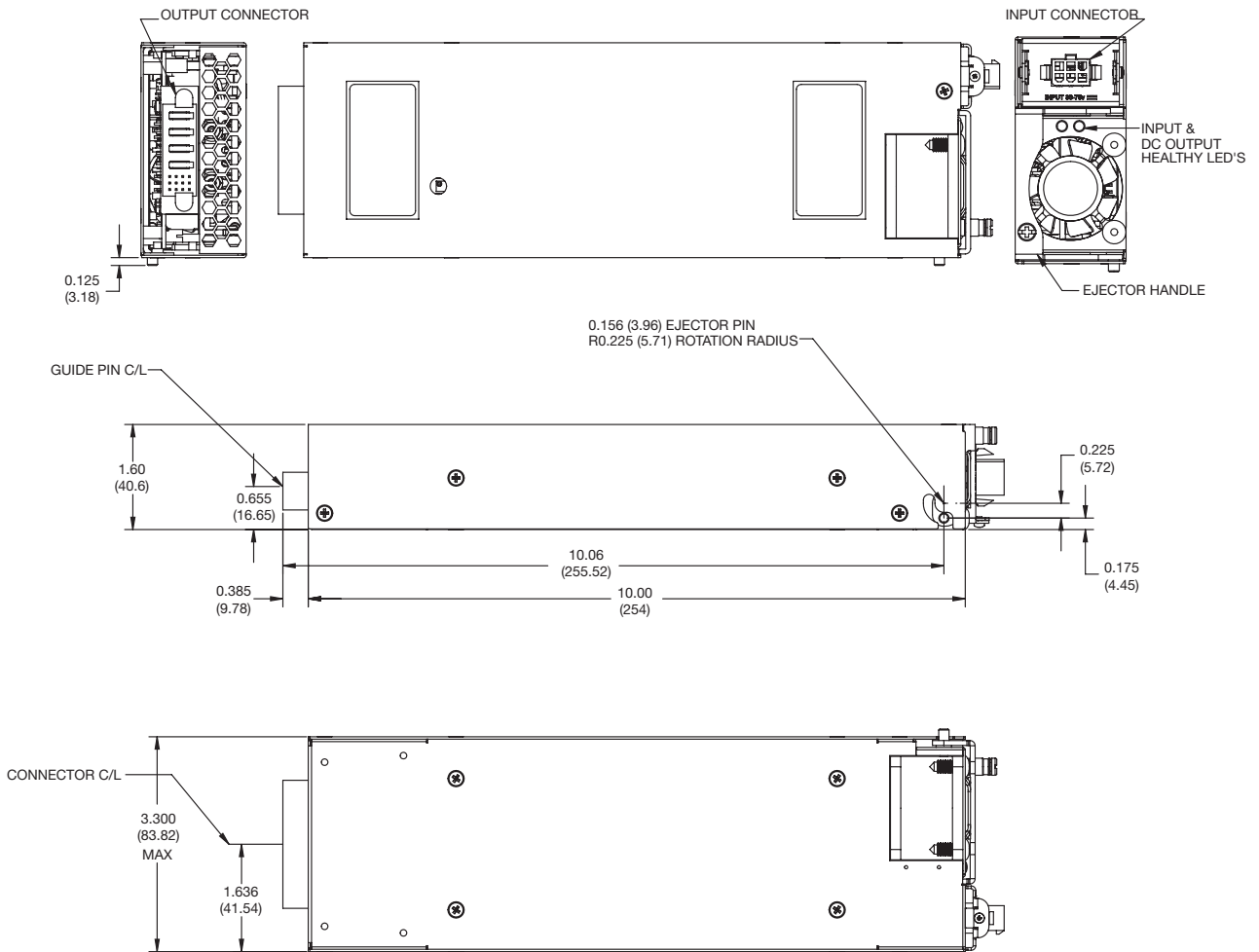

Pin Designator	
Pin	Function
A1	+Sense
A2	Not used
A3	DC OK
B1	-Sense
B2	Not used
B3	DC IN OK
C1	Not used
C2	Not used
C3	5 V Standby
D1	Not used
D2	Inhibit / Enable
D3	5 V Standby Return
P1	-V1
P2	-V1
P3	+V1
P4	+V1

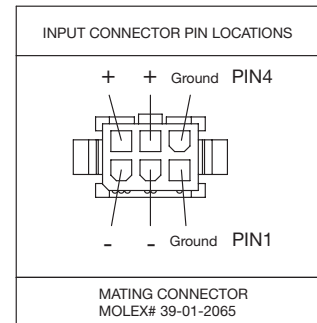

Output Connector FCI# 51722-10401200AA-LF

Thermal Considerations (U Channel)

In order to ensure safe operation of the PSU in the end-use equipment, the temperature of the components listed in the table below must not be exceeded. See drawing on 2nd page of this datasheet for component locations. The temperature should be monitored using K type thermocouples placed on the hottest part of the component (out of any direct air flow). See longform datasheet for further information of service life.

Temperature Measurements (Ambient ≤50 °C)	
Component	Max Temperature °C
L1	90 °C
Q1	105 °C
HS1	85 °C
C25	75 °C
Q2	105 °C

Signals DFA350 & DFA350-H

Input Fail

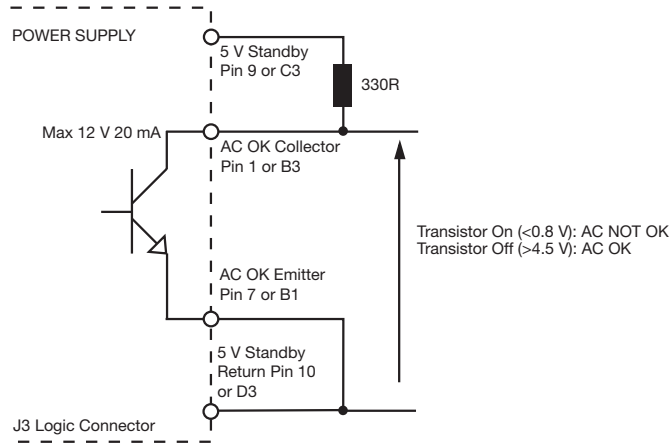

DC OK

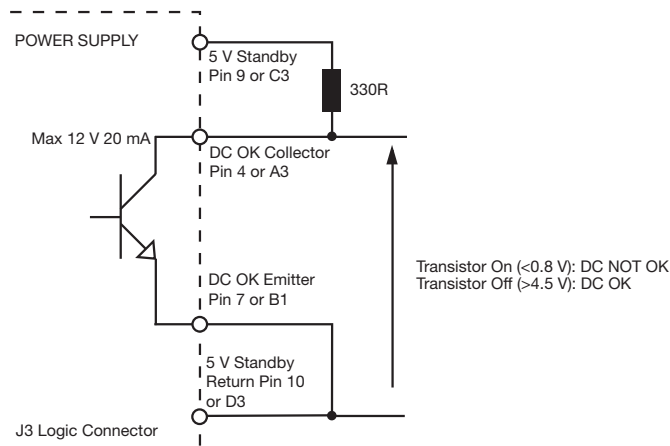

Remote On/Off (Inhibit/Enable)

