

Dip type Clipped Sine wave
20.2 x 12.8 x 7.5 mm



Features

- Ultra Small SMD seam sealed Temperature Compensated Crystal Oscillator units.

Parameters		Electrical Spec.							
Input Voltage (V _{DD})		2.8 V ± 5 %							
Frequency Range		10.0 MHz ~ 40.0 MHz							
Output Wave Form		Clipped Sine wave output							
Output Voltage Level (peak to peak)		0.8 V p-p (min.)							
Frequency Stability (ppm)		± 0.5 ppm	± 1.0 ppm	± 1.5 ppm	± 2.0 ppm	± 2.5 ppm	± 3.0 ppm	± 5.0 ppm	
Frequency Stability vs Temperature	0°C to 50°C	○	○	○	○	○	○	○	
	-10°C to 60°C	△	○	○	○	○	○	○	
	-20°C to 70°C	X	○	○	○	○	○	○	
	-30°C to 75°C	X	○	○	○	○	○	○	
	-40°C to 85°C	X	○	○	○	○	○	○	
Frequency Stability	vs Aging	±1 ppm / year max. at 25C							
	vs Voltage Change	± 0.2 ppm max. , for a ±5% input voltage change .							
	vs Load Change	± 0.2 ppm max. , for a ±10% load condition change .							
	vs Reflow (SMD type)	± 1.0 ppm max. , 1 reflow and measured 24 hours afterwards .							
Current Consumption (max.)		9.6 ~ 15 MHz	15.01 ~ 26.0 MHz	26.01 ~ 40.0 MHz					
		1.5 mA	2.0 mA	2.5 mA					
Electronical Freq. Tuning (EFC) by external control voltage	Control Voltage Center	Standard: +1.5 V ± 1.0 V for all Input voltages.							
	Frequency Deviation Range	± 5.0 ppm (min.) , V _{control} = +1.5 V±1.0 V							
	Linearity	10 % max.							
	Input Impedance	1.0 MΩ min.							
	Modulation Bandwidth	3 KHz min. Measured at -3 dB , V _{control} = +1.5 VDC							
Output Load		10 KΩ // 10 pF ± 10%							
Start - Up Time (Ts)		2.0 m sec. (typ.) , 5.0 m sec. (max.)							
Output Format		DC block , AC coupled							
Rise Time (Tr) / Fall Time (Tf)		10 n sec. (max.)							
Output Format		DC block , AC coupled.							
Storage Temperature		- 50°C to 100°C							
Aging		± 3 ppm per year (max.)							
Phase Noise (typical) [10.000 MHz]		Offset dBc / Hz	10 Hz	100 Hz	1K Hz	10 KHz	100KHz	1 MHz	10 MHz
			-80	-115	-135	-138	-142	-148	-150

General Specifications (Unit : mm)

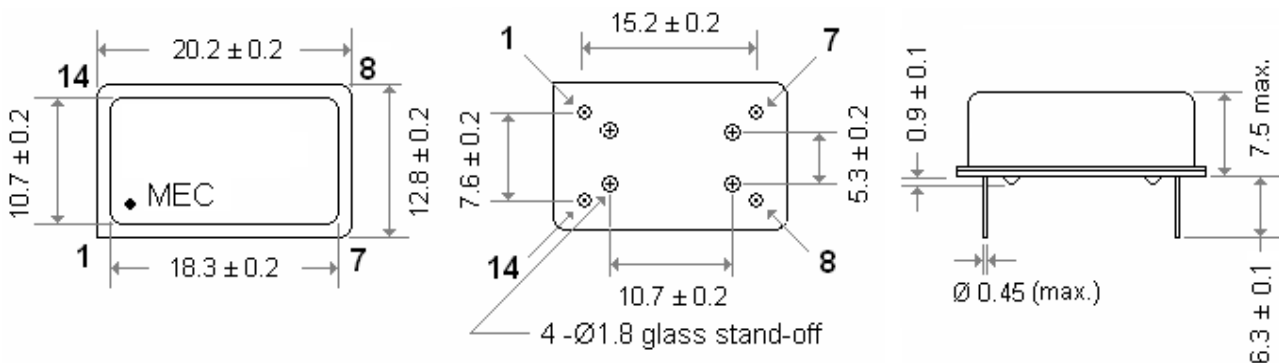

Pin Connections :

- Pin 1 : Voltage control for VCTCXO , No physical pin 1 for TCXO
- Pin 7 : Ground
- Pin 8 : Output
- Pin 14 : Supply Voltage