

PANEL MOUNTING

MAX. PANEL THICKNESS 8.0mm

Ø14.90  
[.587 in]

Ø22.00  
[.866 in]

▲ DOMED ACTUATOR  
BRUSHED STAINLESS STEEL

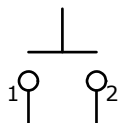
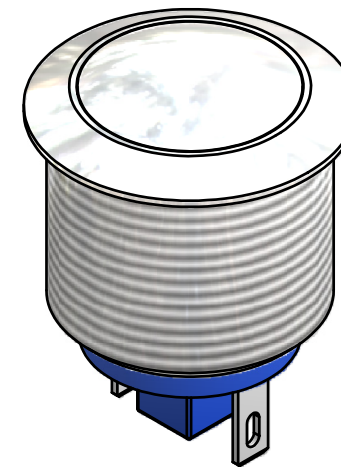

▲ CIRCUIT: SPST

SWITCH FUNCTION	
POS. 1	POS. 2
OFF	(ON)
OPEN	1-2

(ON) = MOMENTARY

3.60 ± .50  
[.142 ± .020 in]

▲ BODY FINISH  
BRUSHED STAINLESS STEEL

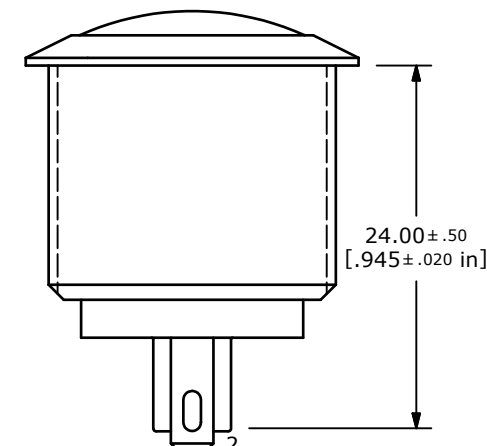
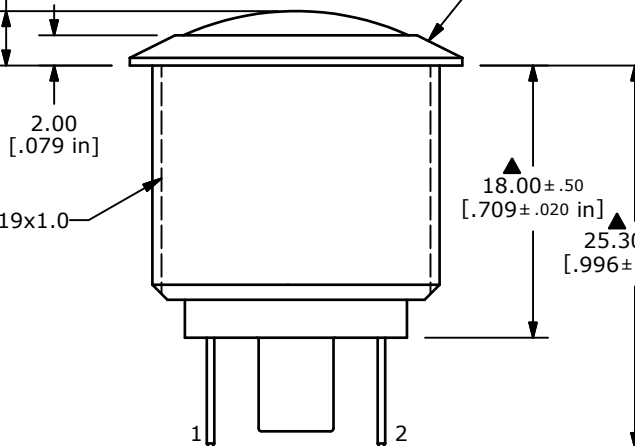

M19x1.0

1

2

2

11.30  
[.445 in]

.50  
[.020 in]

2.80  
[.110 in]

NOTE:

1. ALL DIMENSIONS IN MM [INCH]
2. GENERAL TOLERANCE: X.X = ± 0.4  
X.XX = ± 0.25
3. TERMINAL NOS. FOR REF. ONLY
- ▲ 4. FUNCTION: SPST
- ▲ 5. RATING: 2A @ 48VDC
6. CONTACT RESISTANCE: 50mΩ MAX. @ 1A 12VDC
7. INSULATION RESISTANCE: 1,000MΩ @ 500VDC
8. DIELECTRIC STRENGTH: 2,000VAC MIN. FOR 1 MINUTE
9. ELECTRICAL LIFE: 200,000 CYCLES
10. CONTACT MATERIAL: SILVER PLATED COPPER
11. OPERATING TEMPERATURE: -20°C TO 55°C
12. INGRESS PROTECTION: IP65
13. ▲ DENOTES CRITICAL PARAMETER
14. 2002/95/EC (ROHS) COMPLIANT
- ▲ 15. HARDWARE INCLUDED: HEX NUT AND O-RING (NOT SHOWN)



TITLE PV1S240BB

B	20330	CORRECT TEMP RATING AND CONVERT	12/12/11	BMA
REV	PCR NO	DESCRIPTION	DATE	BY

THE INFORMATION CONTAINED IN THIS DOCUMENT IS PROPRIETARY TO E-SWITCH AND IS NOT TO BE COPIED OR TRANSFERRED

SCALE	DATE	DR	DWG	REV
2:1	12/12/2011	BMA	52-PV1S240BB	B