

This IC is a high speed, low current consumption, 3-wire serial E<sup>2</sup>PROM with a wide operating voltage range. This IC has the capacity of 1 K-bit, 2 K-bit, 4 K-bit, 8 K-bit and 16 K-bit, and the organization is 64 words × 16-bit, 128 words × 16-bit, 256 words × 16-bit, 512 words × 16-bit and 1024 words × 16-bit, respectively. Sequential read is available, at which time addresses are automatically incremented in 16-bit blocks. The communication method is by the Microwire bus.

**Caution** This product is intended to use in general electronic devices such as consumer electronics, office equipment, and communications devices. Before using the product in medical equipment or automobile equipment including car audio, keyless entry and engine control unit, contact to SII Semiconductor Corporation is indispensable.

### ■ Features

- Memory capacity
  - S-93C46C: 1 K-bit (64-word × 16-bit)
  - S-93C56C: 2 K-bit (128-word × 16-bit)
  - S-93C66C: 4 K-bit (256-word × 16-bit)
  - S-93C76C: 8 K-bit (512-word × 16-bit)
  - S-93C86C: 16 K-bit (1024-word × 16-bit)
- Operation voltage range
  - Read: 1.6 V to 5.5 V
  - Write: 1.8 V to 5.5 V
- Operation frequency: 2.0 MHz max.
- Write time: 4.0 ms max.
- Sequential read
- Write protect function during the low power supply voltage
- Function to protect against write due to erroneous instruction recognition
- Endurance: 10<sup>6</sup> cycle / word\*1 (Ta = +85°C)
- Data retention: 100 years (Ta = +25°C)  
50 years (Ta = +85°C)
- Initial delivery state: FFFFh
- Operation temperature range: Ta = -40°C to +85°C
- Lead-free (Sn 100%), halogen-free

\*1. For each address (Word: 16-bit)

### ■ Packages

- 8-Pin SOP (JEDEC)

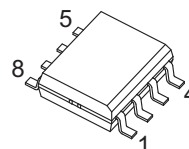

(5.0 × 6.0 × t1.75 mm)

- 8-Pin TSSOP

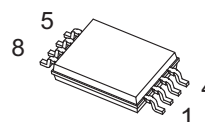

(3.0 × 6.4 × t1.1 mm)

- TMSOP-8

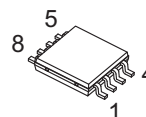

(2.9 × 4.0 × t0.8 mm)

- SNT-8A

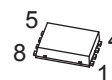

(2.5 × 2.0 × t0.5 mm)

■ Block Diagram

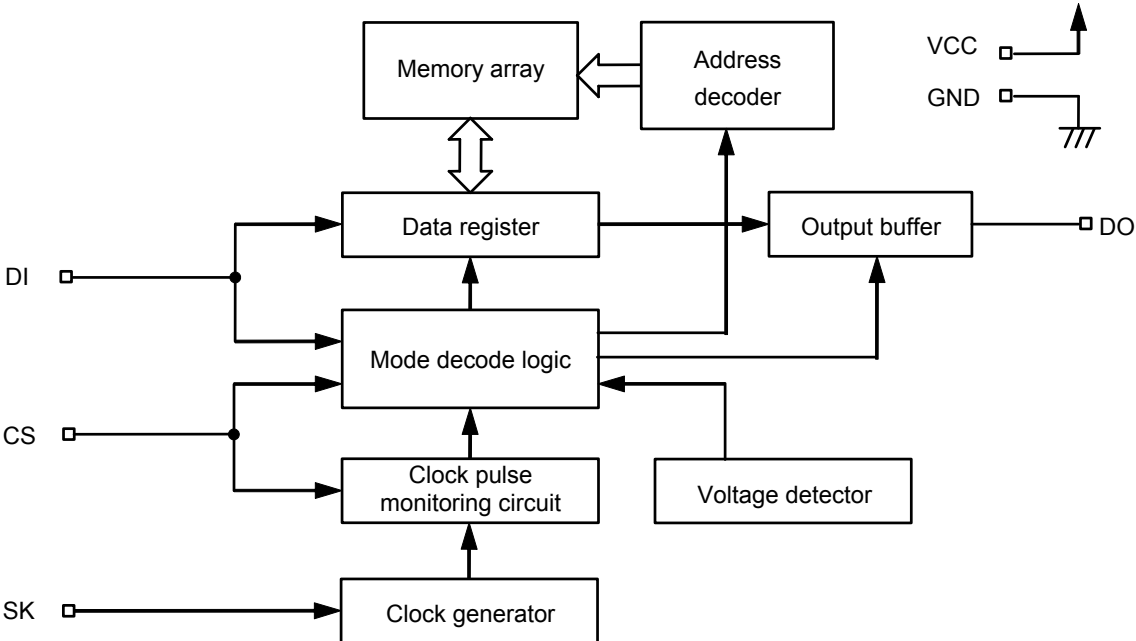

■ **Product Name Structure**

**1. Product name**

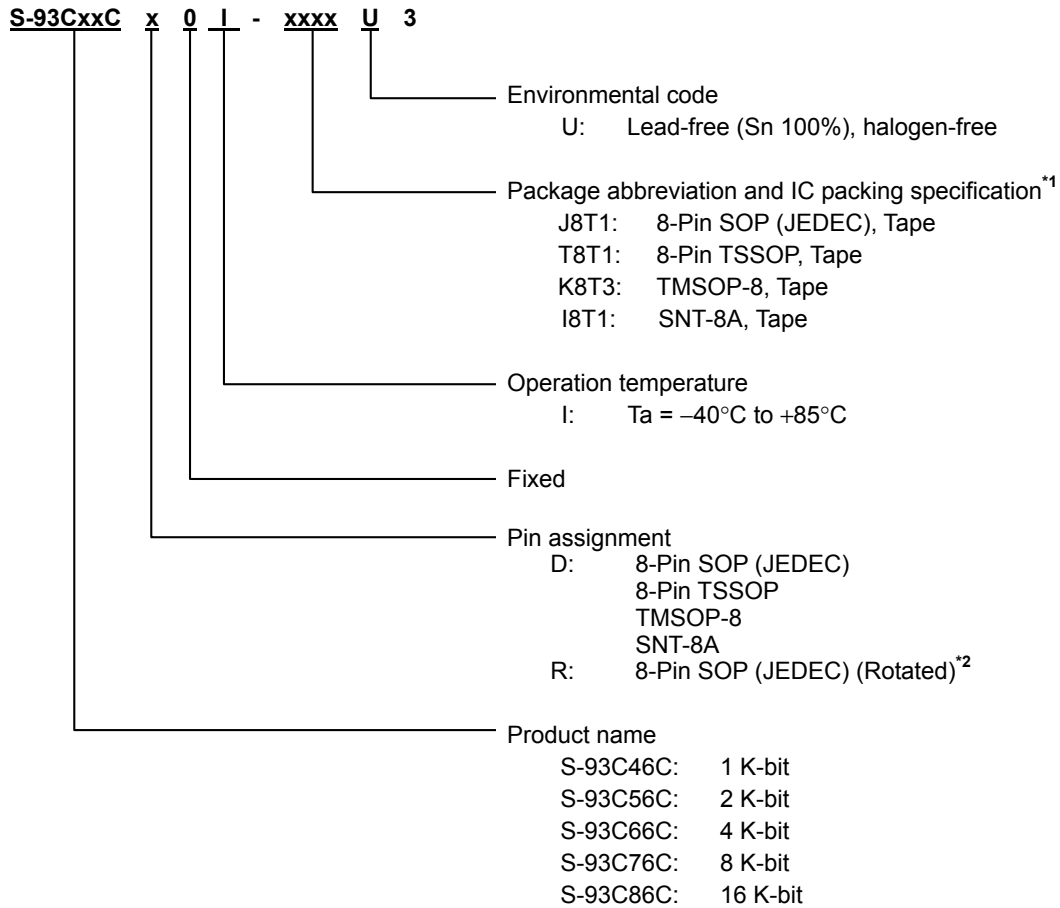

\*1. Refer to the tape drawing  
 \*2. S-93C46C/56C/66C only

**2. Packages**

Package Name	Dimension	Tape	Reel	Land
8-Pin SOP (JEDEC)	FJ008-Z-P-SD	FJ008-Z-C-SD	FJ008-Z-R-SD	-
8-Pin TSSOP	FT008-Z-P-SD	FT008-Z-C-SD	FT008-Z-R-SD	-
TMSOP-8	FM008-A-P-SD	FM008-A-C-SD	FM008-A-R-SD	-
SNT-8A	PH008-A-P-SD	PH008-A-C-SD	PH008-A-R-SD	PH008-A-L-SD

**3. Product name list**

Product Name	Capacity	Package Name
S-93C46CD0I-J8T1U3	1 K-bit	8-Pin SOP (JEDEC)
S-93C46CR0I-J8T1U3	1 K-bit	8-Pin SOP (JEDEC) (Rotated)
S-93C46CD0I-T8T1U3	1 K-bit	8-Pin TSSOP
S-93C46CD0I-K8T3U3	1 K-bit	TMSOP-8
S-93C46CD0I-I8T1U3	1 K-bit	SNT-8A
S-93C56CD0I-J8T1U3	2 K-bit	8-Pin SOP (JEDEC)
S-93C56CR0I-J8T1U3	2 K-bit	8-Pin SOP (JEDEC) (Rotated)
S-93C56CD0I-T8T1U3	2 K-bit	8-Pin TSSOP
S-93C56CD0I-K8T3U3	2 K-bit	TMSOP-8
S-93C56CD0I-I8T1U3	2 K-bit	SNT-8A
S-93C66CD0I-J8T1U3	4 K-bit	8-Pin SOP (JEDEC)
S-93C66CR0I-J8T1U3	4 K-bit	8-Pin SOP (JEDEC) (Rotated)
S-93C66CD0I-T8T1U3	4 K-bit	8-Pin TSSOP
S-93C66CD0I-K8T3U3	4 K-bit	TMSOP-8
S-93C66CD0I-I8T1U3	4 K-bit	SNT-8A
S-93C76CD0I-J8T1U3	8 K-bit	8-Pin SOP (JEDEC)
S-93C76CD0I-T8T1U3	8 K-bit	8-Pin TSSOP
S-93C76CD0I-K8T3U3	8 K-bit	TMSOP-8
S-93C76CD0I-I8T1U3	8 K-bit	SNT-8A
S-93C86CD0I-J8T1U3	16 K-bit	8-Pin SOP (JEDEC)
S-93C86CD0I-T8T1U3	16 K-bit	8-Pin TSSOP
S-93C86CD0I-K8T3U3	16 K-bit	TMSOP-8
S-93C86CD0I-I8T1U3	16 K-bit	SNT-8A

## ■ Pin Configuration

### 1. 8-Pin SOP (JEDEC)

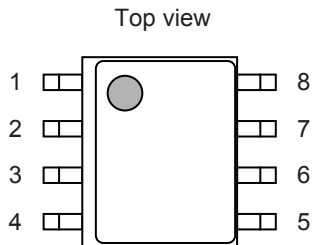

Pin No.	Symbol	Description
1	CS	Chip select input
2	SK	Serial clock input
3	DI	Serial data input
4	DO	Serial data output
5	GND	Ground
6	TEST <sup>*1</sup>	Test
7	NC	No connection
8	VCC	Power supply

### 2. 8-Pin SOP (JEDEC) (Rotated)

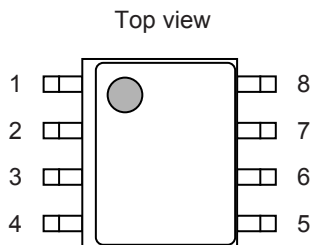

Pin No.	Symbol	Description
1	NC	No connection
2	VCC	Power supply
3	CS	Chip select input
4	SK	Serial clock input
5	DI	Serial data input
6	DO	Serial data output
7	GND	Ground
8	TEST <sup>*1</sup>	Test

### 3. 8-Pin TSSOP

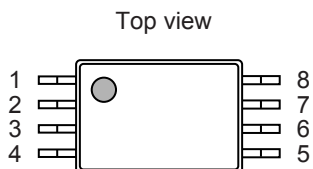

Pin No.	Symbol	Description
1	CS	Chip select input
2	SK	Serial clock input
3	DI	Serial data input
4	DO	Serial data output
5	GND	Ground
6	TEST <sup>*1</sup>	Test
7	NC	No connection
8	VCC	Power supply

- \*1. Connect to GND or the VCC pin, or set to open. Even if this pin is not connected, performance is not affected so long as the absolute maximum rating is not exceeded.

**4. TMSOP-8**

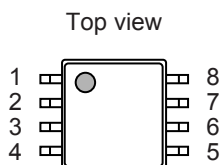

Pin No.	Symbol	Description
1	CS	Chip select input
2	SK	Serial clock input
3	DI	Serial data input
4	DO	Serial data output
5	GND	Ground
6	TEST <sup>*1</sup>	Test
7	NC	No connection
8	VCC	Power supply

**5. SNT-8A**

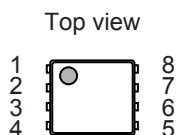

Pin No.	Symbol	Description
1	CS	Chip select input
2	SK	Serial clock input
3	DI	Serial data input
4	DO	Serial data output
5	GND	Ground
6	TEST <sup>*1</sup>	Test
7	NC	No connection
8	VCC	Power supply

\*1. Connect to GND or the VCC pin, or set to open. Even if this pin is not connected, performance is not affected so long as the absolute maximum rating is not exceeded.

## ■ Absolute Maximum Ratings

Table 1

Item	Symbol	Absolute Maximum Rating	Unit
Power supply voltage	V <sub>CC</sub>	-0.3 to +6.5	V
Input voltage	V <sub>IN</sub>	-0.3 to +6.5	V
Output voltage	V <sub>OUT</sub>	-0.3 to V <sub>CC</sub> + 0.3	V
Operation ambient temperature	T <sub>opr</sub>	-40 to +85	°C
Storage temperature	T <sub>stg</sub>	-65 to +150	°C

**Caution** The absolute maximum ratings are rated values exceeding which the product could suffer physical damage. These values must therefore not be exceeded under any conditions.

## ■ Recommended Operating Conditions

Table 2

Item	Symbol	Condition	Ta = -40°C to +85°C		Unit
			Min.	Max.	
Power supply voltage	V <sub>CC</sub>	READ, EWDS	1.6	5.5	V
		WRITE, ERASE, EWEN	1.8	5.5	V
		WRAL, ERAL	2.5	5.5	V
High level input voltage	V <sub>IH</sub>	V <sub>CC</sub> = 4.5 V to 5.5 V	2.0	V <sub>CC</sub>	V
		V <sub>CC</sub> = 2.7 V to 4.5 V	0.8 × V <sub>CC</sub>	V <sub>CC</sub>	V
		V <sub>CC</sub> = 1.6 V to 2.7 V	0.8 × V <sub>CC</sub>	V <sub>CC</sub>	V
Low level input voltage	V <sub>IL</sub>	V <sub>CC</sub> = 4.5 V to 5.5 V	0.0	0.8	V
		V <sub>CC</sub> = 2.7 V to 4.5 V	0.0	0.2 × V <sub>CC</sub>	V
		V <sub>CC</sub> = 1.6 V to 2.7 V	0.0	0.15 × V <sub>CC</sub>	V

## ■ Pin Capacitance

Table 3

(Ta = +25°C, f = 1.0 MHz, V<sub>CC</sub> = 5.0 V)

Item	Symbol	Condition	Min.	Max.	Unit
Input capacitance	C <sub>IN</sub>	V <sub>IN</sub> = 0 V	–	8	pF
Output capacitance	C <sub>OUT</sub>	V <sub>OUT</sub> = 0 V	–	10	pF

## ■ Endurance

Table 4

Item	Symbol	Operation Ambient Temperature	Min.	Max.	Unit
Endurance	N <sub>w</sub>	Ta = -40°C to +85°C	10 <sup>6</sup>	–	cycle / word*1

\*1. For each address (Word: 16-bit)

## ■ Data Retention

Table 5

Item	Symbol	Operation Ambient Temperature	Min.	Max.	Unit
Data retention	–	Ta = +25°C	100	–	year
		Ta = -40°C to +85°C	50	–	year

■ DC Electrical Characteristics

**Table 6**

Item	Symbol	Condition	Ta = -40°C to +85°C								Unit
			V <sub>CC</sub> = 1.6 V to 1.8 V, f <sub>SK</sub> = 0.5 MHz		V <sub>CC</sub> = 1.8 V to 2.5 V, f <sub>SK</sub> = 1.0 MHz		V <sub>CC</sub> = 2.5 V to 4.5 V, f <sub>SK</sub> = 2.0 MHz		V <sub>CC</sub> = 4.5 V to 5.5 V, f <sub>SK</sub> = 2.0 MHz		
			Min.	Max.	Min.	Max.	Min.	Max.	Min.	Max.	
Current consumption (read)	I <sub>CC1</sub>	No load at DO pin	-	0.4	-	0.4	-	0.5	-	0.8	mA

**Table 7**

Item	Symbol	Condition	Ta = -40°C to +85°C				Unit
			V <sub>CC</sub> = 1.8 V to 4.5 V		V <sub>CC</sub> = 4.5 V to 5.5 V		
			Min.	Max.	Min.	Max.	
Current consumption (write)	I <sub>CC2</sub>	No load at DO pin	-	2.0	-	2.0	mA

**Table 8**

Item	Symbol	Condition	Ta = -40°C to +85°C						Unit
			V <sub>CC</sub> = 1.6 V to 2.5 V		V <sub>CC</sub> = 2.5 V to 4.5 V		V <sub>CC</sub> = 4.5 V to 5.5 V		
			Min.	Max.	Min.	Max.	Min.	Max.	
Standby current consumption	I <sub>SB</sub>	CS = GND, DO = Open, Other input pins are V <sub>CC</sub> or GND	-	2.0	-	2.0	-	2.0	μA
Input leakage current	I <sub>LI</sub>	CS, SK, DI, V <sub>IN</sub> = GND to V <sub>CC</sub>	-	1.0	-	1.0	-	1.0	μA
Output leakage current	I <sub>LO</sub>	DO, V <sub>OUT</sub> = GND to V <sub>CC</sub>	-	1.0	-	1.0	-	1.0	μA
Pull-down current	I <sub>PD</sub>	TEST, V <sub>IN</sub> = GND ~ V <sub>CC</sub>	-	1.2	-	1.2	-	1.2	μA
Low level output voltage	V <sub>OL</sub>	I <sub>OL</sub> = 2.1 mA	-	-	-	-	-	0.4	V
		I <sub>OL</sub> = 100 μA	-	0.1	-	0.1	-	0.1	V
High level output voltage	V <sub>OH</sub>	I <sub>OH</sub> = -400 μA	-	-	-	-	2.4	-	V
		I <sub>OH</sub> = -100 μA	-	-	V <sub>CC</sub> - 0.3	-	V <sub>CC</sub> - 0.3	-	V
		I <sub>OH</sub> = -10 μA	V <sub>CC</sub> - 0.2	-	V <sub>CC</sub> - 0.2	-	V <sub>CC</sub> - 0.2	-	V
Data hold voltage of write enable latch	V <sub>DH</sub>	Only program disable mode	1.5	-	1.5	-	1.5	-	V

■ AC Electrical Characteristics

Table 9 Measurement Conditions

Input pulse voltage	$0.1 \times V_{CC}$ to $0.9 \times V_{CC}$
Output reference voltage	$0.5 \times V_{CC}$
Output load	100 pF

Table 10

Item	Symbol	Ta = -40°C to +85°C								Unit
		V <sub>CC</sub> = 1.6 V to 1.8 V		V <sub>CC</sub> = 1.8 V to 2.5 V		V <sub>CC</sub> = 2.5 V to 4.5 V		V <sub>CC</sub> = 4.5 V to 5.5 V		
		Min.	Max.	Min.	Max.	Min.	Max.	Min.	Max.	
CS pin setup time	t <sub>CSS</sub>	0.4	-	0.2	-	0.15	-	0.15	-	μs
CS pin hold time	t <sub>CSH</sub>	0	-	0	-	0	-	0	-	μs
CS pin deselect time	t <sub>CDS</sub>	0.4	-	0.2	-	0.2	-	0.2	-	μs
Data setup time	t <sub>DS</sub>	0.2	-	0.1	-	0.1	-	0.1	-	μs
Data hold time	t <sub>DH</sub>	0.2	-	0.1	-	0.1	-	0.1	-	μs
Output delay time	t <sub>PD</sub>	-	0.8	-	0.6	-	0.25	-	0.25	μs
Clock frequency*1	f <sub>SK</sub>	0	0.5	0	1.0	0	2.0	0	2.0	MHz
SK clock time "L"*1	t <sub>SKL</sub>	0.5	-	0.2	-	0.2	-	0.1	-	μs
SK clock time "H"*1	t <sub>SKH</sub>	0.5	-	0.2	-	0.2	-	0.1	-	μs
Output disable time	t <sub>HZ1</sub> , t <sub>HZ2</sub>	0	0.5	0	0.2	0	0.2	0	0.15	μs
Output enable time	t <sub>SV</sub>	0	0.5	0	0.2	0	0.2	0	0.15	μs
Write time	t <sub>PR</sub>	-	4.0	-	4.0	-	4.0	-	4.0	ms

\*1. The clock cycle of the SK clock (frequency f<sub>SK</sub>) is 1/f<sub>SK</sub> μs. This clock cycle is determined by a combination of several AC characteristics. Note that the clock cycle cannot be set as (1/f<sub>SK</sub>) = t<sub>SKL</sub> (min.) + t<sub>SKH</sub> (min.) by minimizing the SK clock cycle time.

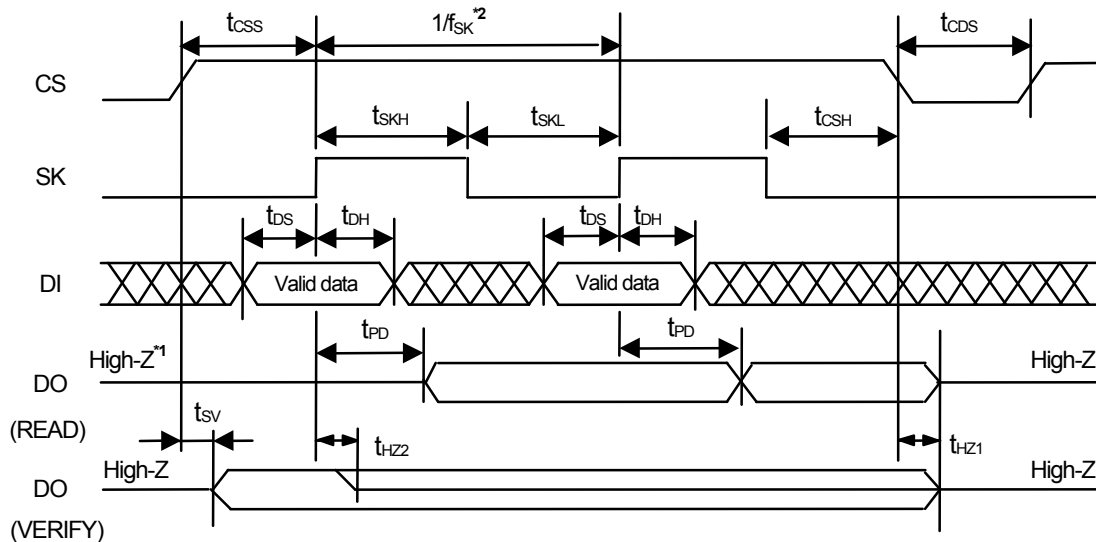

- \*1. Indicates high impedance.
- \*2. 1/f<sub>SK</sub> is the SK clock cycle. This clock cycle is determined by a combination of several AC characteristics. Note that the clock cycle cannot be set as (1/f<sub>SK</sub>) = t<sub>SKL</sub> (min.) + t<sub>SKH</sub> (min.) by minimizing the SK clock cycle time.

Figure 1 Timing Chart

## ■ Pin Functions

### 1. CS (chip select input) pin

This is an input pin to set a chip in the select status. In the "L" input level, this IC is in the non-select status and its output is "High-Z". This IC is in standby as long as it is not in write inside. This IC goes in active by setting the chip select to "H". Input any instruction code after power-on and a rising of chip select.

### 2. SK (serial clock input) pin

This is a clock input pin to set the timing of serial data. A start bit, an operation code, an address and a write data are received at a rising edge of clock. Data is output during rising edge of clock.

### 3. DI (serial data input) pin

This pin is to input serial data. This pin receives a start bit, an operation code, an address and a write data. This pin latches data at rising edge of serial clock.

### 4. SO (serial data output) pin

This pin is to output serial data. The data output changes at rising edge of serial clock.

### 5. TEST (test input) pin

This is an input pin in test mode. Connect to GND or the VCC pin, or set to open. Because this pin has a built-in pull-down element, pull-down current flows when it connected to VCC pin.

## ■ Initial Delivery State

Initial delivery state of all addresses is "FFFFh".

## ■ Instruction Sets

### 1. S-93C46C

Table 11

Instruction SK input clock	Start Bit	Operation Code		Address						Data
	1	2	3	4	5	6	7	8	9	10 to 25
READ (Data read)	1	1	0	A5	A4	A3	A2	A1	A0	D15 to D0 output <sup>*1</sup>
WRITE (Data write)	1	0	1	A5	A4	A3	A2	A1	A0	D15 to D0 input
ERASE (Data erase)	1	1	1	A5	A4	A3	A2	A1	A0	–
WRAL (Chip write)	1	0	0	0	1	x	x	x	x	D15 to D0 input
ERAL (Chip erase)	1	0	0	1	0	x	x	x	x	–
EWEN (Write enable)	1	0	0	1	1	x	x	x	x	–
EWDS (Write disable)	1	0	0	0	0	x	x	x	x	–

\*1. When the 16-bit data in the specified address has been output, the data in the next address is output.

**Remark** x = Don't care.

### 2. S-93C56C

Table 12

Instruction SK input clock	Start Bit	Operation Code		Address							Data	
	1	2	3	4	5	6	7	8	9	10	11	12 to 27
READ (Data read)	1	1	0	x	A6	A5	A4	A3	A2	A1	A0	D15 to D0 output <sup>*1</sup>
WRITE (Data write)	1	0	1	x	A6	A5	A4	A3	A2	A1	A0	D15 to D0 input
ERASE (Data erase)	1	1	1	x	A6	A5	A4	A3	A2	A1	A0	–
WRAL (Chip write)	1	0	0	0	1	x	x	x	x	x	x	D15 to D0 input
ERAL (Chip erase)	1	0	0	1	0	x	x	x	x	x	x	–
EWEN (Write enable)	1	0	0	1	1	x	x	x	x	x	x	–
EWDS (Write disable)	1	0	0	0	0	x	x	x	x	x	x	–

\*1. When the 16-bit data in the specified address has been output, the data in the next address is output.

**Remark** x = Don't care.

### 3. S-93C66C

Table 13

Instruction SK input clock	Start Bit	Operation Code		Address							Data	
	1	2	3	4	5	6	7	8	9	10	11	12 to 27
READ (Data read)	1	1	0	A7	A6	A5	A4	A3	A2	A1	A0	D15 to D0 output <sup>*1</sup>
WRITE (Data write)	1	0	1	A7	A6	A5	A4	A3	A2	A1	A0	D15 to D0 input
ERASE (Data erase)	1	1	1	A7	A6	A5	A4	A3	A2	A1	A0	–
WRAL (Chip write)	1	0	0	0	1	x	x	x	x	x	x	D15 to D0 input
ERAL (Chip erase)	1	0	0	1	0	x	x	x	x	x	x	–
EWEN (Write enable)	1	0	0	1	1	x	x	x	x	x	x	–
EWDS (Write disable)	1	0	0	0	0	x	x	x	x	x	x	–

\*1. When the 16-bit data in the specified address has been output, the data in the next address is output.

**Remark** x = Don't care.

**4. S-93C76C**

**Table 14**

Instruction SK input clock	Start Bit	Operation Code		Address										Data
	1	2	3	4	5	6	7	8	9	10	11	12	13	14 to 29
READ (Data read)	1	1	0	x	A8	A7	A6	A5	A4	A3	A2	A1	A0	D15 to D0 output <sup>*1</sup>
WRITE (Data write)	1	0	1	x	A8	A7	A6	A5	A4	A3	A2	A1	A0	D15 to D0 input
ERASE (Data erase)	1	1	1	x	A8	A7	A6	A5	A4	A3	A2	A1	A0	–
WRAL (Chip write)	1	0	0	0	1	x	x	x	x	x	x	x	x	D15 to D0 input
ERAL (Chip erase)	1	0	0	1	0	x	x	x	x	x	x	x	x	–
EWEN (Write enable)	1	0	0	1	1	x	x	x	x	x	x	x	x	–
EWDS (Write disable)	1	0	0	0	0	x	x	x	x	x	x	x	x	–

\*1. When the 16-bit data in the specified address has been output, the data in the next address is output.

**Remark** x = Don't care.

**5. S-93C86C**

**Table 15**

Instruction SK input clock	Start Bit	Operation Code		Address										Data
	1	2	3	4	5	6	7	8	9	10	11	12	13	14 to 29
READ (Data read)	1	1	0	A9	A8	A7	A6	A5	A4	A3	A2	A1	A0	D15 to D0 output <sup>*1</sup>
WRITE (Data write)	1	0	1	A9	A8	A7	A6	A5	A4	A3	A2	A1	A0	D15 to D0 input
ERASE (Data erase)	1	1	1	A9	A8	A7	A6	A5	A4	A3	A2	A1	A0	–
WRAL (Chip write)	1	0	0	0	1	x	x	x	x	x	x	x	x	D15 to D0 input
ERAL (Chip erase)	1	0	0	1	0	x	x	x	x	x	x	x	x	–
EWEN (Write enable)	1	0	0	1	1	x	x	x	x	x	x	x	x	–
EWDS (Write disable)	1	0	0	0	0	x	x	x	x	x	x	x	x	–

\*1. When the 16-bit data in the specified address has been output, the data in the next address is output.

**Remark** x = Don't care.

## ■ Operation

All instructions are executed by inputting the DI pin in synchronization with the rising of the SK pulse after the CS pin goes to "H". An instruction set is input in the order of start bit, instruction, address, and data.

Instruction input finishes when the CS pin goes to "L". "L" must be input to the CS pin between commands during  $t_{CDS}$ . While "L" is being input to the CS pin, this IC is in standby mode, so the SK pin and the DI pin inputs are invalid and no instructions are allowed.

### 1. Start Bit

A start bit is recognized when the DI pin goes to "H" at the rising of the SK pulse after the CS pin goes to "H". After the CS pin goes to "H", a start bit is not recognized even if the SK pulse is input as long as the DI pin is "L".

#### 1.1 Dummy clock

The SK clocks input while the DI pin is "L" before a start bit is input are called dummy clocks. Dummy clocks are effective when aligning the number of instruction sets (clocks) sent by the CPU with those required for serial memory operation. For example, when the CPU instruction set is 16 bits, the number of instruction set clocks can be adjusted by inserting the 7-bit dummy clock in S-93C46C, the 5-bit dummy clock in S-93C56C/66C and the 3-bit dummy clock in S-93C76C/86C.

#### 1.2 Start bit input failure

- (1) When the output of the DO pin is "H" during the verify period after a write operation, if "H" is input to the DI pin at the rising of the SK pulse, this IC recognizes that a start bit has been input. To prevent this failure, input "L" to the DI pin during the verify operation period (refer to "3.1 Verify operation").
- (2) When a 3-wire interface is configured by connecting the DI input pin and the DO output pin, a period in which the data output from the CPU and the serial memory collide may be generated, preventing successful input of the start bit. Take the measures described in "■ 3-Wire Interface (Direct Connection between DI Pin and DO Pin)".

### 2. Reading (READ)

The READ instruction reads data from a specified address.

After the CS pin goes to "H", input an instruction in the order of the start bit, read instruction, and address. Since the last input address ( $A_0$ ) has been latched, the output status of the DO pin changes from "High-Z" to "L", which is held until the next rising of the SK pulse. 16-bit data starts to be output in synchronization with the next rising of the SK pulse.

#### 2.1 Sequential read

After the 16-bit data at the specified address has been output, inputting the SK pulse while the CS pin is "H" automatically increments the address, and causes the 16-bit data at the next address to be output sequentially. The above method makes it possible to read the data in the whole memory space. The last address ( $A_n \dots A_1 A_0 = 1 \dots 1 1$ ) rolls over to the top address ( $A_n \dots A_1 A_0 = 0 \dots 0 0$ ).

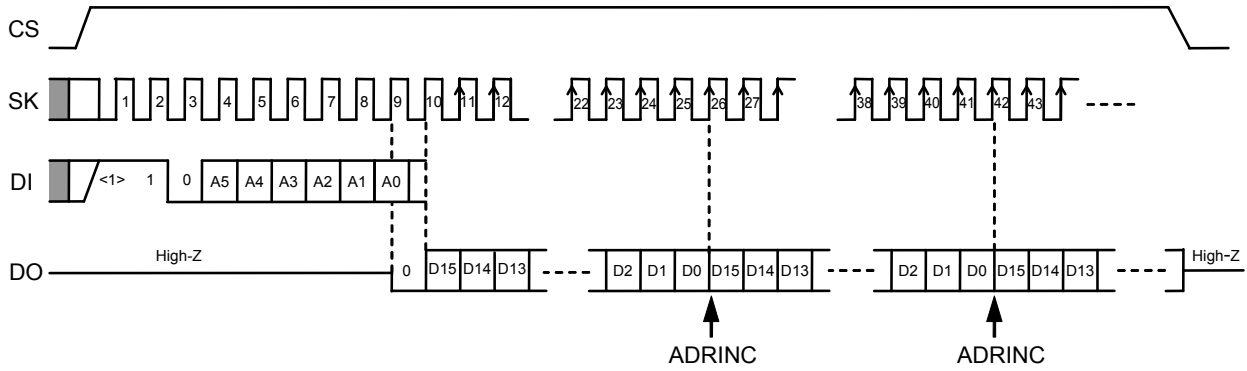

**Figure 2 Read Timing (S-93C46C)**

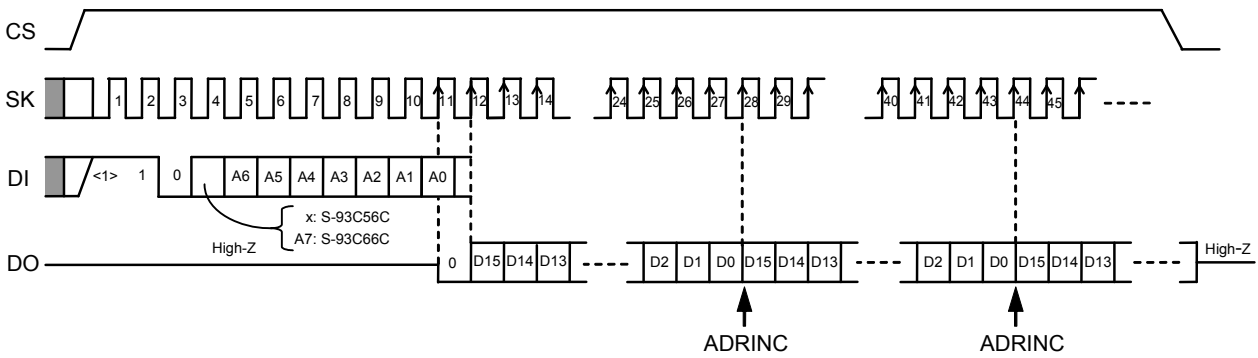

**Figure 3 Read Timing (S-93C56C/66C)**

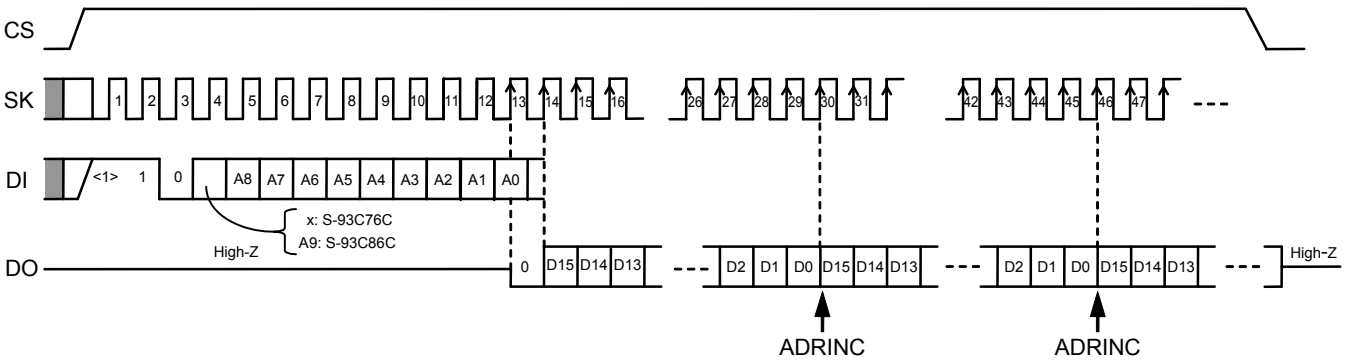

**Figure 4 Read Timing (S-93C76C/86C)**

### 3. Writing (WRITE, ERASE, WRAL, ERAL)

A write operation includes four write instructions: data write (WRITE), data erase (ERASE), chip write (WRAL), and chip erase (ERAL).

A write instruction (WRITE, ERASE, WRAL, ERAL) starts a write operation to the memory cell when "L" is input to the CS pin after a specified number of clocks have been input. The SK pin and the DI pin inputs are invalid during the write period, so do not input an instruction.

Input an instruction while the output status of the DO pin is "H" or "High-Z".

A write operation is valid only in program enable mode (refer to "4. Write enable (EWEN) / write disable (EWDS)").

#### 3.1 Verify operation

A write operation executed by any instruction is completed within 4 ms (write time  $t_{PR}$ ), so if the completion of the write operation is recognized, the write cycle can be minimized. A sequential operation to confirm the status of a write operation is called a verify operation.

##### 3.1.1 Operation method

After the write operation has started (CS pin = "L"), the status of the write operation can be verified by confirming the output status of the DO pin by inputting "H" to the CS pin again. This sequence is called a verify operation, and the period that "H" is input to the CS pin after the write operation has started is called the verify operation period.

The relationship between the output status of the DO pin and the write operation during the verify operation period is as follows.

- (1) DO pin = "L": Writing in progress (busy)
- (2) DO pin = "H": Writing completed (ready)

##### 3.1.2 Operation example

There are two methods to perform a verify operation: Waiting for a change in the output of the DO pin while keeping the CS pin "H", or suspending the verify operation (CS pin = "L") once and then performing it again to verify the output of the DO pin. The latter method allows the CPU to perform other processing during the wait period, allowing an efficient system to be designed.

- Caution**
1. Input "L" to the DI pin during a verify operation.
  2. If "H" is input to the DI pin at the rising of the SK pulse when the output status of the DO pin is "H", this IC latches the instruction assuming that a start bit has been input. In this case, note that the DO pin immediately enters "High-Z".

**3.2 Writing data (WRITE)**

To write 16-bit data to a specified address, change the CS pin to "H" and then input the WRITE instruction, address, and 16-bit data following the start bit. The write operation starts when the CS pin goes to "L". There is no need to set the data to "1" before writing. When the clocks more than the specified number have been input, the clock pulse monitoring circuit cancels the WRITE instruction. For details of the clock pulse monitoring circuit, refer to "■ Function to Protect Against Write due to Erroneous Instruction Recognition".

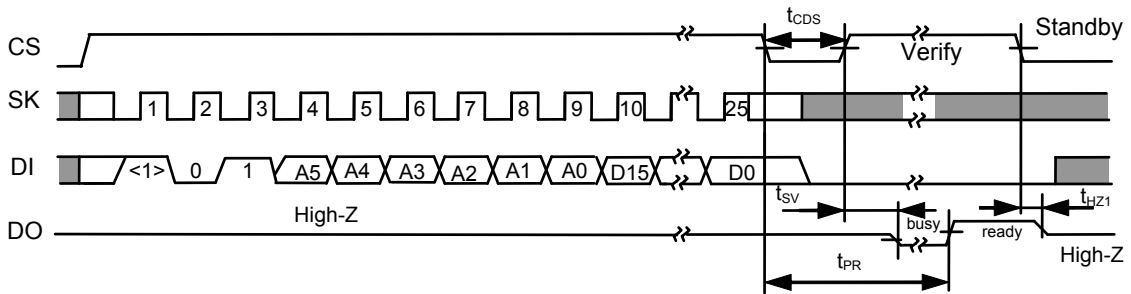

**Figure 5 Data Write Timing (S-93C46C)**

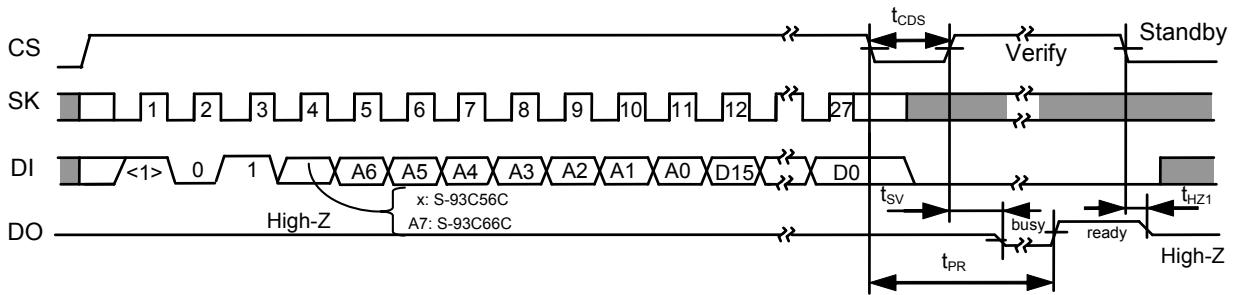

**Figure 6 Data Write Timing (S-93C56C/66C)**

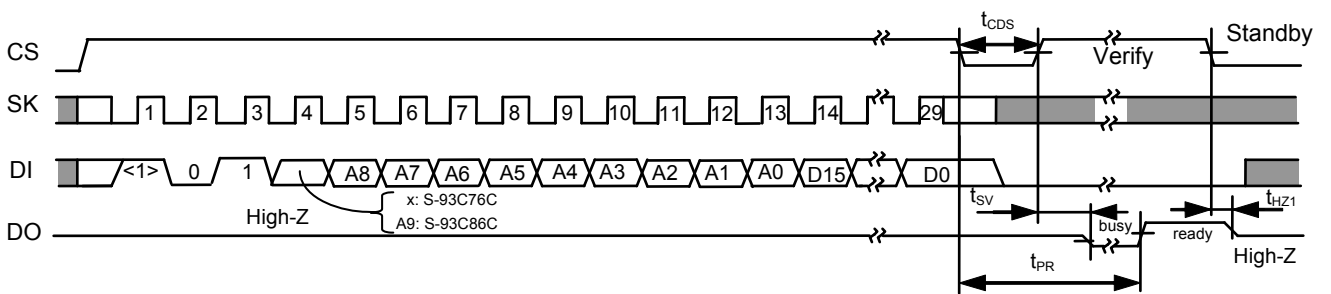

**Figure 7 Data Write Timing (S-93C76C/86C)**

3.3 Erasing data (ERASE)

To erase 16-bit data at a specified address, set all 16 bits of the data to "1", change the CS pin to "H", and then input the ERASE instruction and address following the start bit. There is no need to input data. The data erase operation starts when the CS pin goes to "L". When the clocks more than the specified number have been input, the clock pulse monitoring circuit cancels the ERASE instruction. For details of the clock pulse monitoring circuit, refer to "■ Function to Protect Against Write due to Erroneous Instruction Recognition".

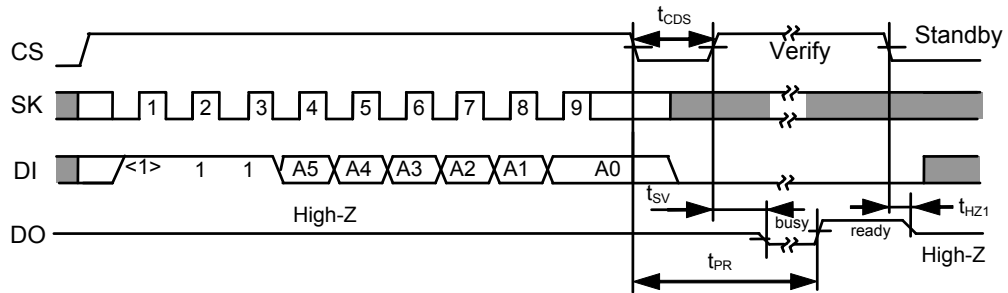

Figure 8 Data Erase Timing (S-93C46C)

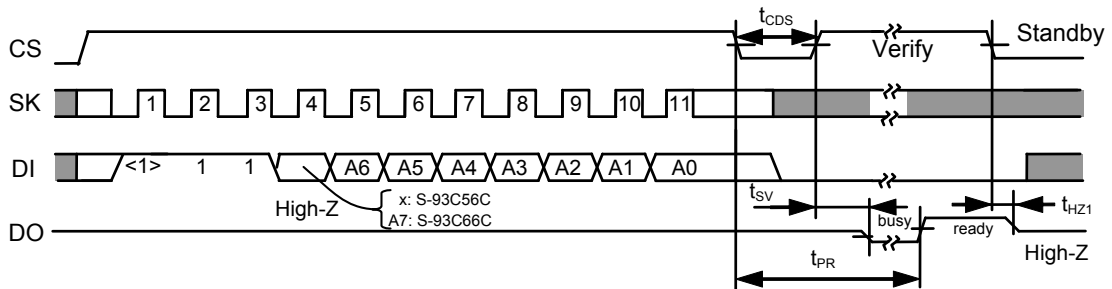

Figure 9 Data Erase Timing (S-93C56C/66C)

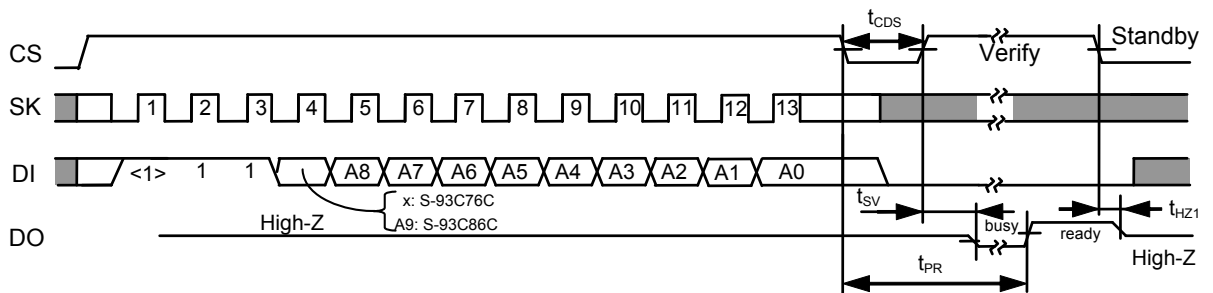
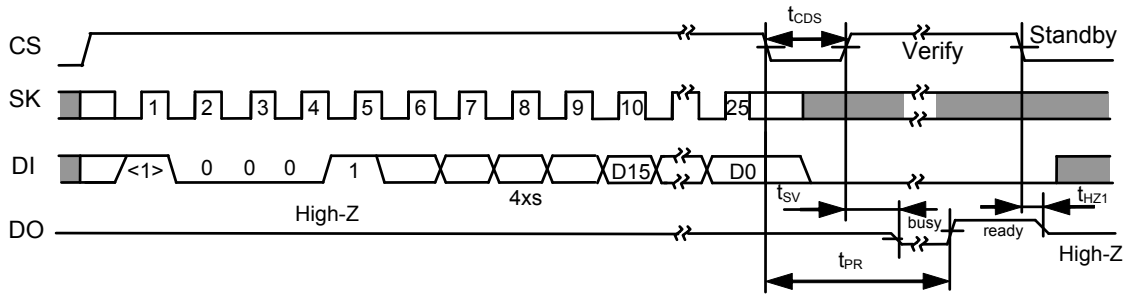

Figure 10 Data Erase Timing (S-93C76C/86C)

**3.4 Writing to chip (WRAL)**

To write the same 16-bit data to the entire memory address space, change the CS pin to "H", and then input the WRAL instruction, an address, and 16-bit data following the start bit. Any address can be input. The write operation starts when the CS pin goes to "L". There is no need to set the data to "1" before writing. When the clocks more than the specified number have been input, the clock pulse monitoring circuit cancels the WRAL instruction. For details of the clock pulse monitoring circuit, refer to "■ Function to Protect Against Write due to Erroneous Instruction Recognition".



**Figure 11 Chip Write Timing (S-93C46C)**

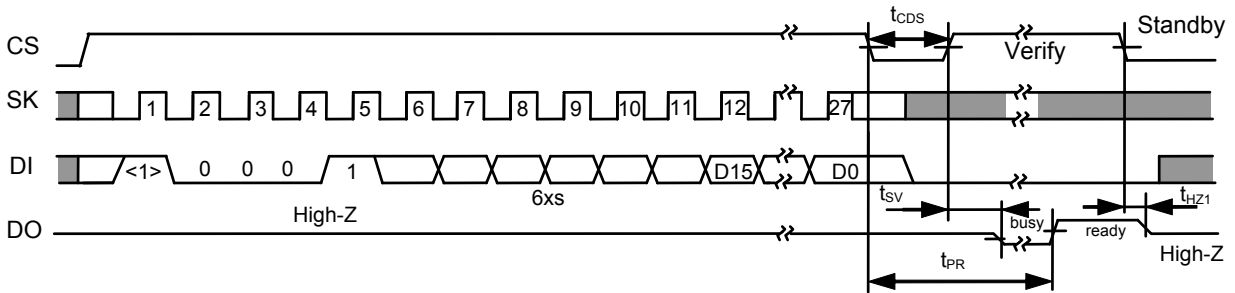

**Figure 12 Chip Write Timing (S-93C56C/66C)**

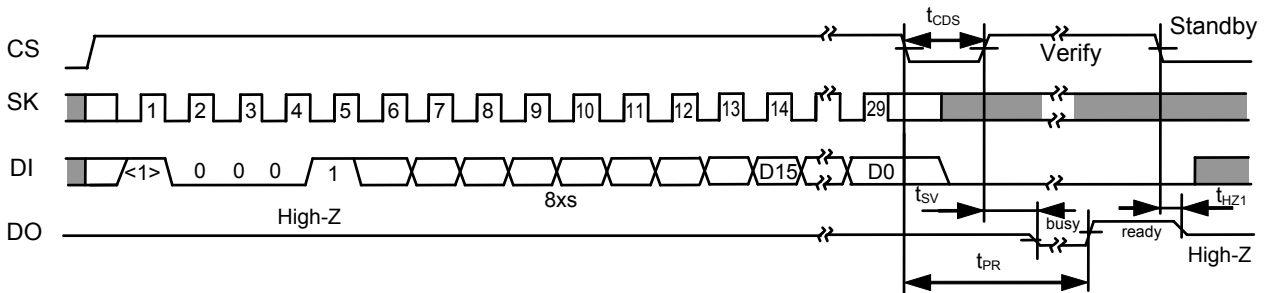

**Figure 13 Chip Write Timing (S-93C76C/86C)**

### 3.5 Erasing chip (ERAL)

To erase the data of the entire memory address space, set all the data to "1", change the CS pin to "H", and then input the ERAL instruction and an address following the start bit. There is no need to input data. The chip erase operation starts when the CS pin goes to "L". When the clocks more than the specified number have been input, the clock pulse monitoring circuit cancels the ERAL instruction. For details of the clock pulse monitoring circuit, refer to "■ Function to Protect Against Write due to Erroneous Instruction Recognition".

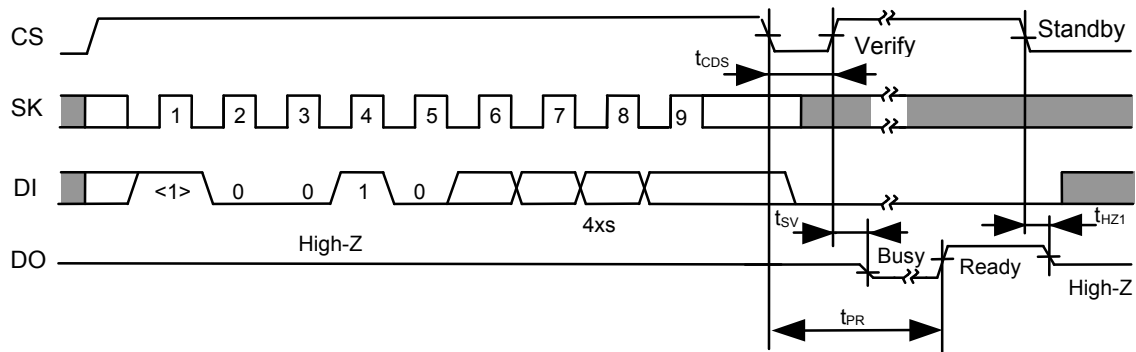

Figure 14 Chip Erase Timing (S-93C46C)

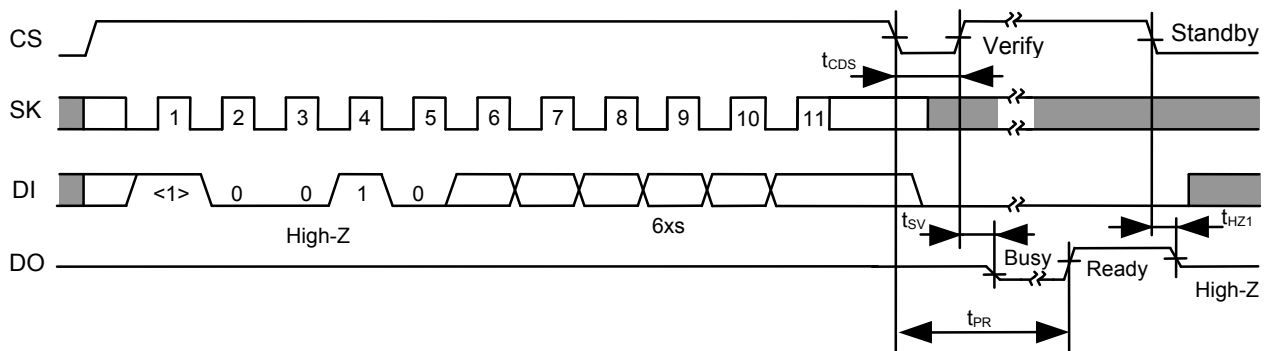

Figure 15 Chip Erase Timing (S-93C56C/66C)

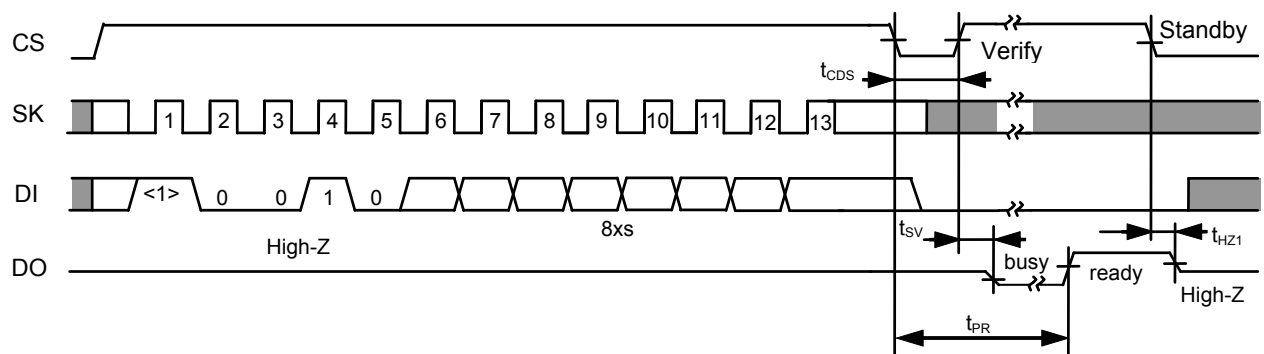

Figure 16 Chip Erase Timing (S-93C76C/86C)

**4. Write enable (EWEN) / write disable (EWDS)**

The EWEN instruction is an instruction that enables a write operation. The status in which a write operation is enabled is called the program enable mode.

The EWDS instruction is an instruction that disables a write operation. The status in which a write operation is disabled is called the program disable mode.

After the CS pin goes to "H", input an instruction in the order of the start bit, EWEN or EWDS instruction, and address (optional). Each mode becomes valid by inputting "L" to the CS pin after the last address (optional) has been input.

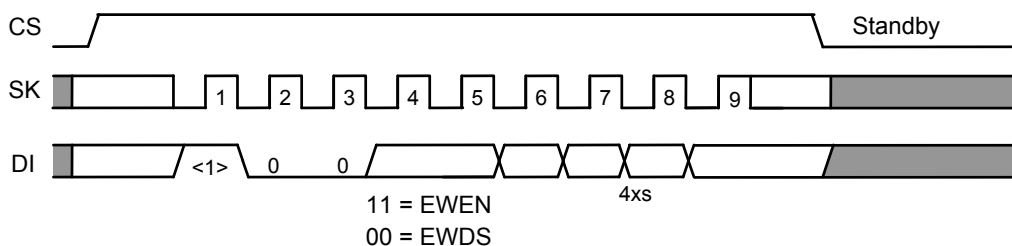

**Figure 17 Write Enable / Disable Timing (S-93C46C)**

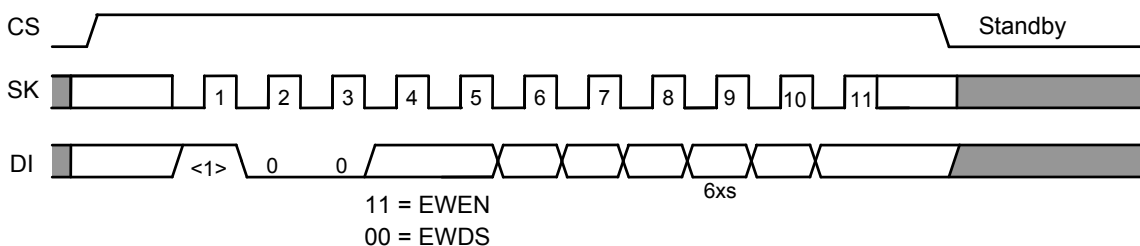

**Figure 18 Write Enable / Disable Timing (S-93C56C/66C)**

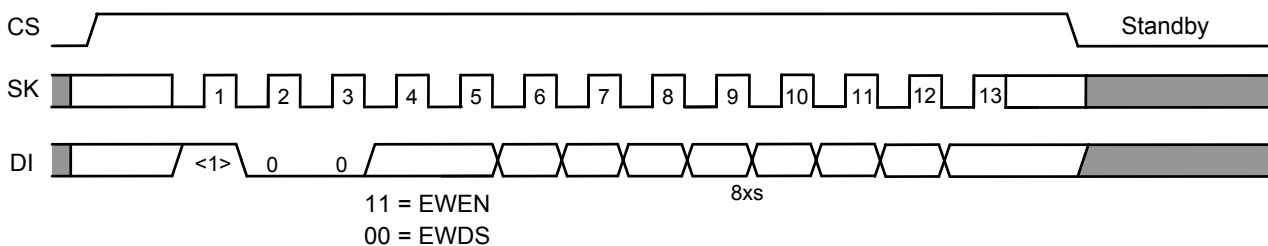

**Figure 19 Write Enable / Disable Timing (S-93C76C/86C)**

**Remark** It is recommended to execute an EWDS instruction for preventing an incorrect write operation if a write instruction is erroneously recognized when executing instructions other than write instruction, and immediately after power-on and before power-off.

### ■ Write Protect Function during the Low Power Supply Voltage

This IC provides a built-in detection circuit to detect a low power supply voltage. When the power supply voltage is low or at power-on, the write instructions (WRITE, ERASE, WRAL, and ERAL) are cancelled, and the write disable (EWDS) status is automatically set. The detection voltage and the release voltage are 1.2 V typ. (refer to **Figure 20**).

Therefore, when a write operation is performed after the power supply voltage has dropped and then risen again up to the level at which writing is possible, a write enable instruction (EWEN) must be sent before a write instruction (WRITE, ERASE, WRAL, or ERAL) is executed.

When the power supply voltage drops during a write operation, the data being written to an address at that time is not guaranteed.

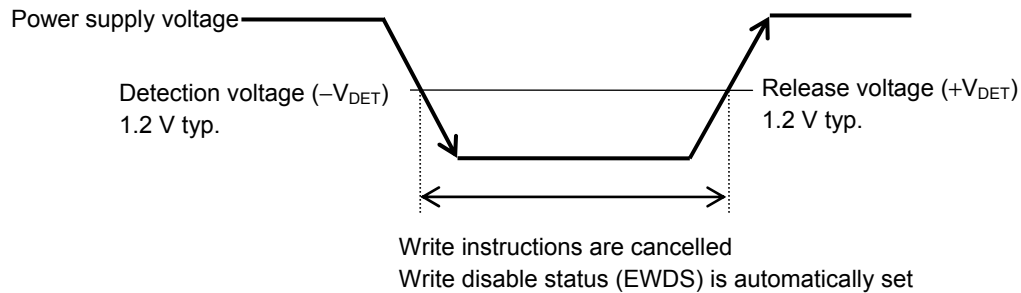

**Figure 20** Operation during the Low Power Supply Voltage

■ **Function to Protect Against Write due to Erroneous Instruction Recognition**

This IC provides a built-in clock pulse monitoring circuit which is used to prevent an erroneous write operation by canceling write instructions (WRITE, ERASE, WRAL, and ERAL) recognized erroneously due to an erroneous clock count caused by the application of noise pulses or double counting of clocks. Instructions are cancelled if a clock pulse whose count other than the one specified for each write instruction (WRITE, ERASE, WRAL, or ERAL) is detected.

**Example: Erroneous Recognition of EWDS as ERASE**

Example of S-93C76C/86C

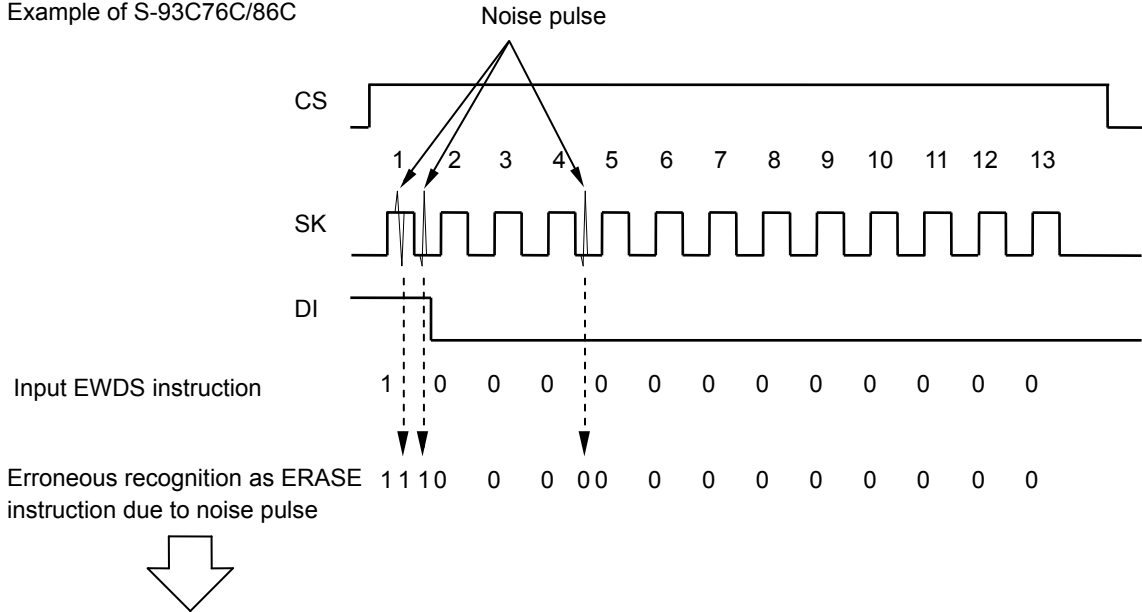

In products that do not incorporate a clock pulse monitoring circuit, "FFFFh" is mistakenly written to address 00h. However the S-93C76C/86C detects the overcount and cancels the instruction without performing a write operation.

**Figure 21 Example of Clock Pulse Monitoring Circuit Operation**

### ■ 3-Wire Interface (Direct Connection between DI Pin and DO Pin)

There are two types of serial interface configurations: a 4-wire interface configured using the CS pin, the SK pin, the DI pin and the DO pin and a 3-wire interface that connects the DI pin and the DO pin.

When the 3-wire interface is employed, a period in which the data output from the CPU and the data output from the serial memory collide may occur, causing a malfunction. To prevent such a malfunction, connect the DI pin and the DO pin of this IC via a resistor (10 k $\Omega$  to 100 k $\Omega$ ) so that the data output from the CPU takes precedence in being input to the DI pin (refer to **Figure 22**).

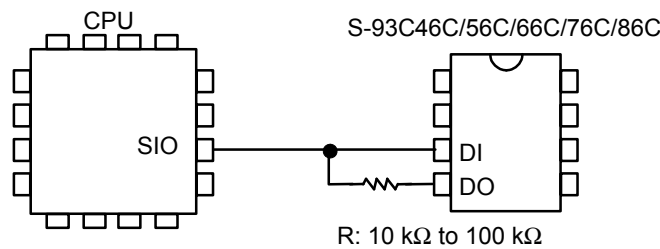

**Figure 22 Connection of 3-Wire Interface**

### ■ Input Pin and Output Pin

#### 1. Connection of input pin

All input pins in this IC have the CMOS structure. Do not set these pins in "High-Z" during operation when you design. Especially, set the CS pin to "L" at power-on, power-off, and during standby. The error write does not occur as long as the CS pin is "L". Set the CS pin to GND via a resistor (the pull-down resistor of 10 k $\Omega$  to 100 k $\Omega$ ).

To prevent the error for sure, it is recommended to use equivalent pull-down resistors for input pins other than the CS pin.

#### 2. Equivalent circuit of input pin and output pin

**Figure 23**, **Figure 24** and **Figure 25** show the equivalent circuits of input pins in this IC. In **Figure 23** and **Figure 24**, none of the input pins incorporate pull-up and pull-down elements, so special care must be taken when designing to prevent a floating status.

In **Figure 25**, the TEST pin has a built-in pull-down element.

**Figure 26** shows the equivalent circuit of the output pin. This pin has the tri-state output of "H" / "L" / "High-Z".

2.1 Input pin

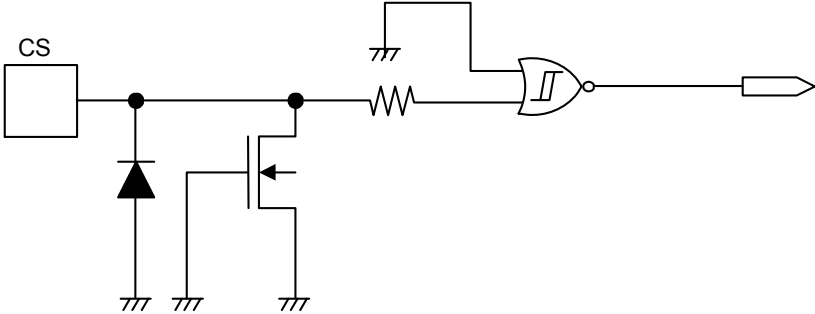

Figure 23 CS Pin

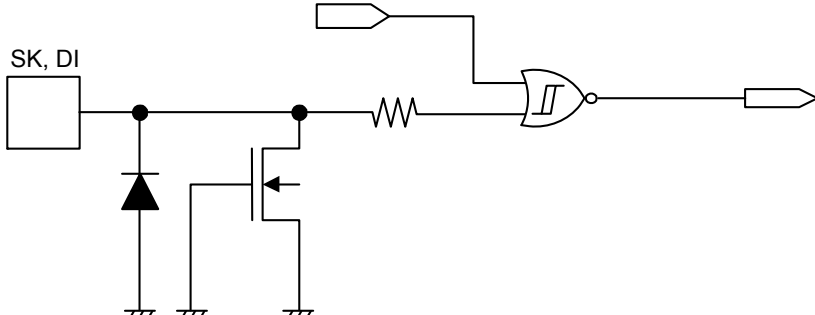

Figure 24 SK, DI Pin

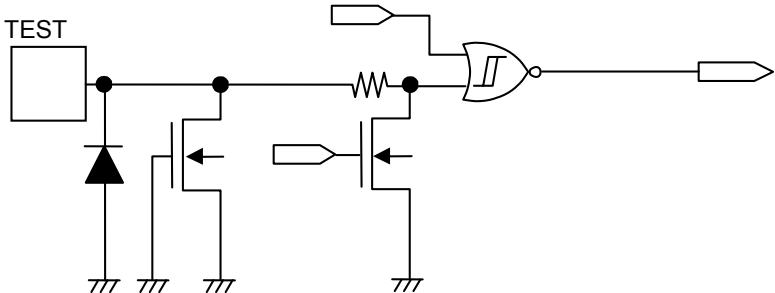

Figure 25 TEST Pin

## 2.2 Output pin

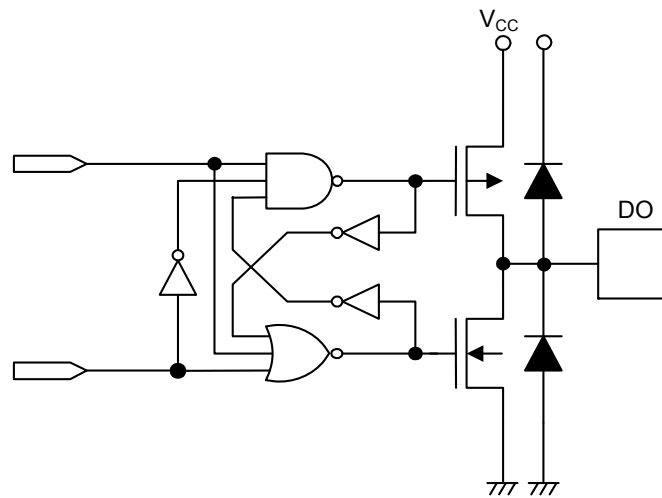

Figure 26 DO Pin

## 3. Input pin noise suppression time

This IC has a built-in low-pass filter at the SK pin, the DI pin and the CS pin to suppress noise. If the supply voltage is 5.0 V, noise with a pulse width of 20 ns or less at room temperature can be suppressed by the low-pass filter.

Note that noise with a pulse width of more than 20 ns is recognized as a pulse since the noise can not be suppressed if the voltage exceeds  $V_{IH} / V_{IL}$ .

## ■ Precautions

- Do not operate these ICs in excess of the absolute maximum ratings. Attention should be paid to the power supply voltage, especially. The surge voltage which exceeds the absolute maximum ratings can cause latch-up and malfunction. Perform operations after confirming the detailed operation condition in the data sheet.
- Operations with moisture on this IC's pins may occur malfunction by short-circuit between pins. Especially, in occasions like picking this IC up from low temperature tank during the evaluation. Be sure that not remain frost on this IC's pin to prevent malfunction by short-circuit.  
Also attention should be paid in using on environment, which is easy to dew for the same reason.
- Do not apply an electrostatic discharge to this IC that exceeds the performance ratings of the built-in electrostatic protection circuit.
- SII Semiconductor Corporation claims no responsibility for any and all disputes arising out of or in connection with any infringement of the products including this IC upon patents owned by a third party.

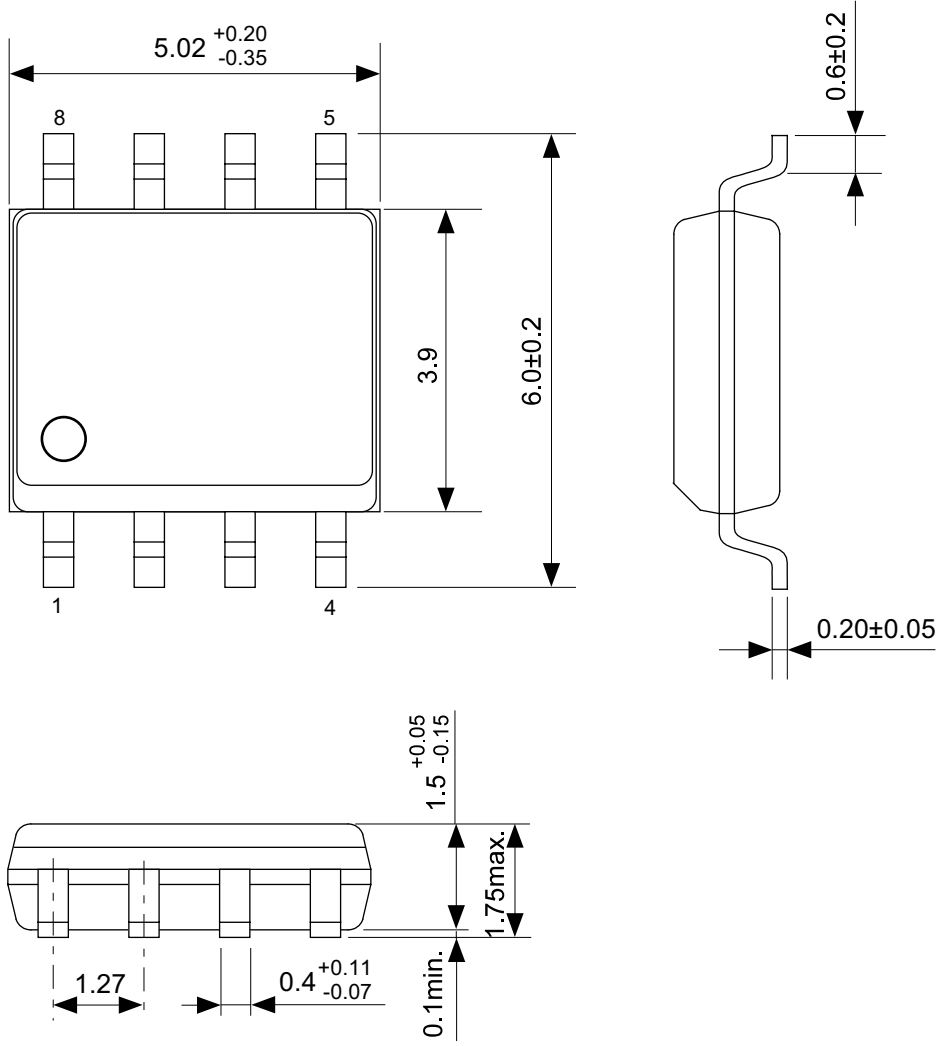

No. FJ008-Z-P-SD-2.1

TITLE	SOP8J-Z-PKG Dimensions
No.	FJ008-Z-P-SD-2.1
ANGLE	
UNIT	mm
SII Semiconductor Corporation	

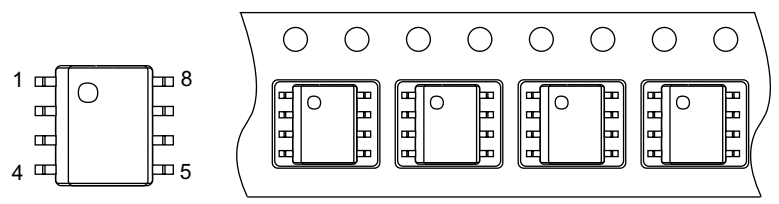
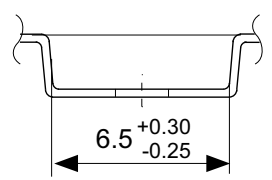
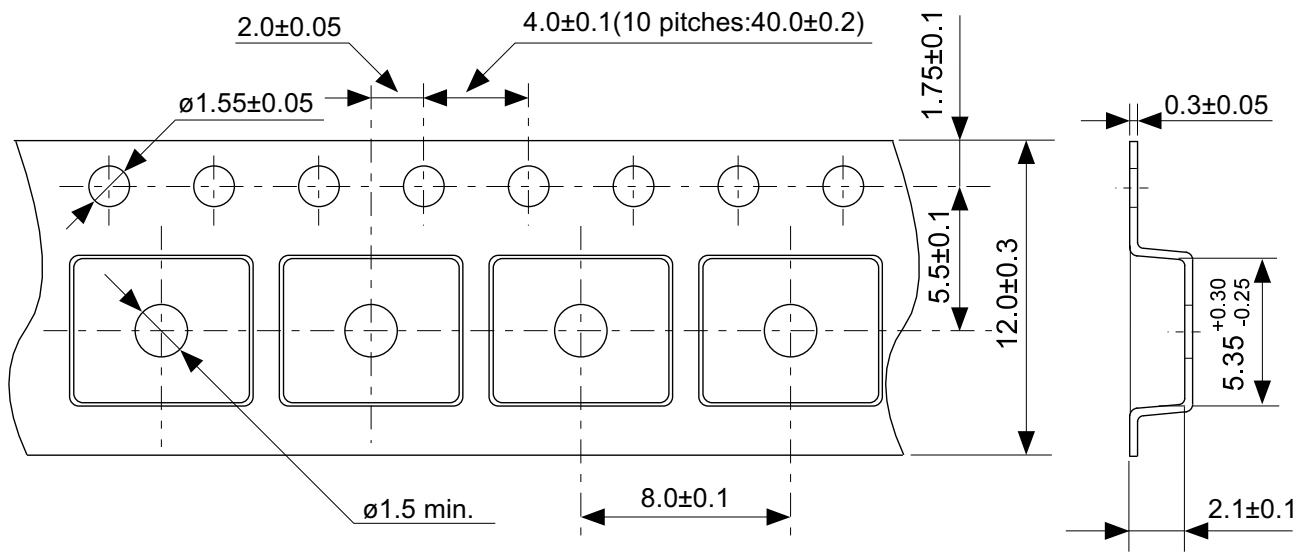

→  
Feed direction

No. FJ008-Z-C-SD-1.0

TITLE	SOP8J-Z-Carrier Tape
No.	FJ008-Z-C-SD-1.0
ANGLE	
UNIT	mm

SII Semiconductor Corporation

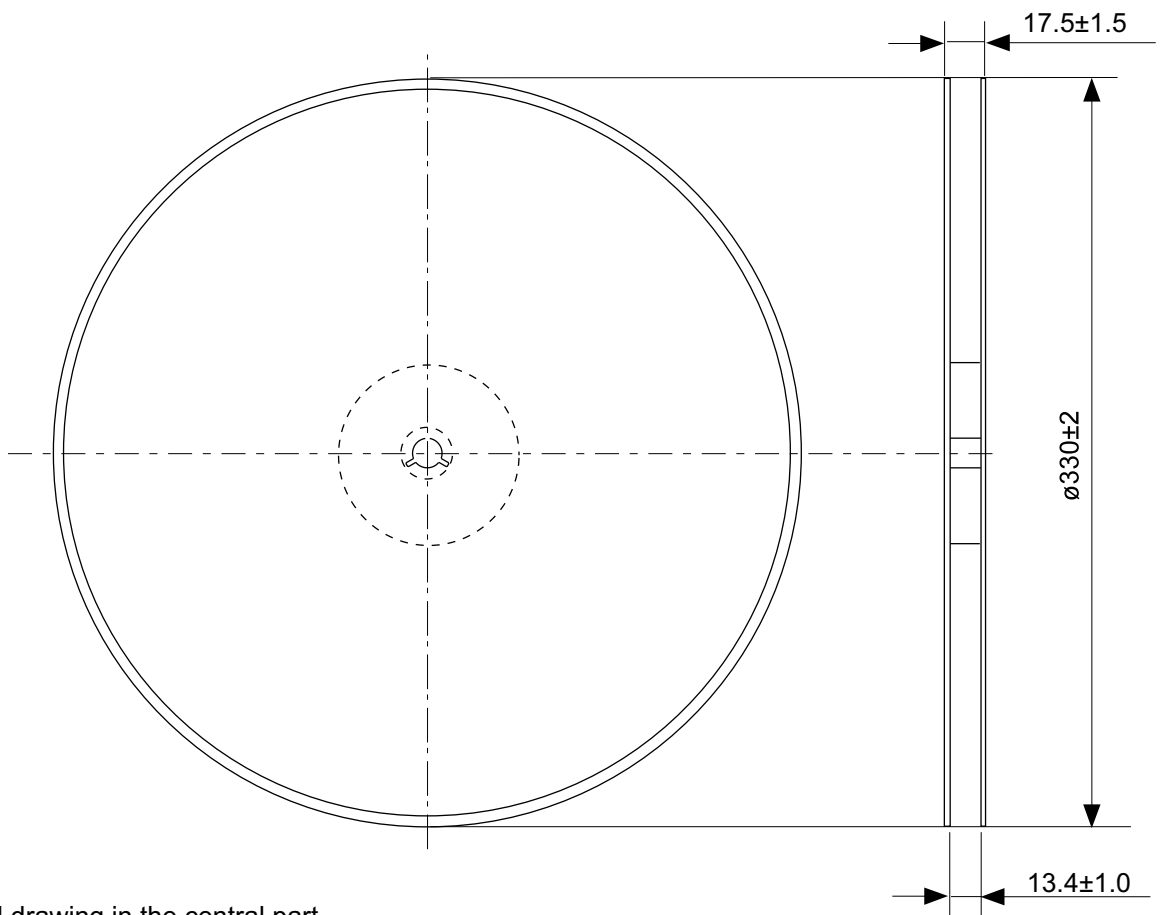

Enlarged drawing in the central part

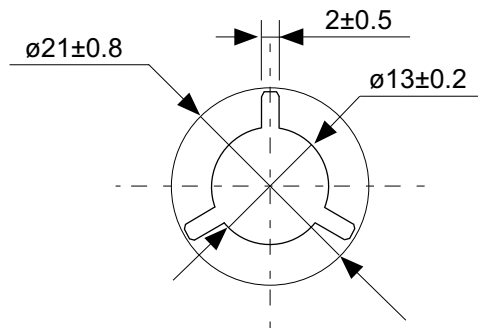

No. FJ008-Z-R-SD-1.0

TITLE	SOP8J-Z-Reel		
No.	FJ008-Z-R-SD-1.0		
ANGLE		QTY.	4,000
UNIT	mm		
SII Semiconductor Corporation			

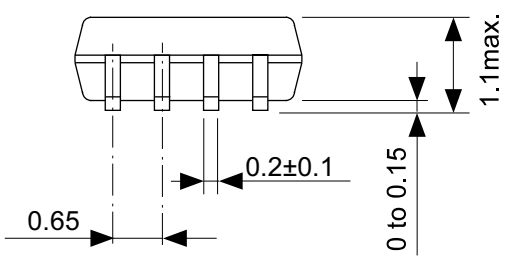
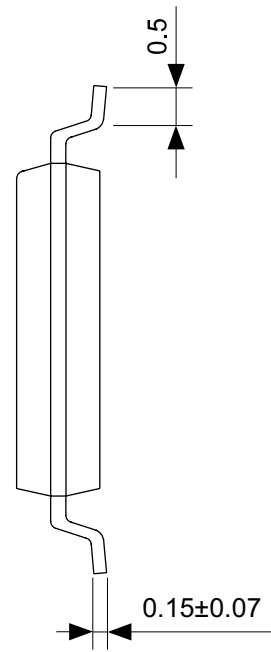
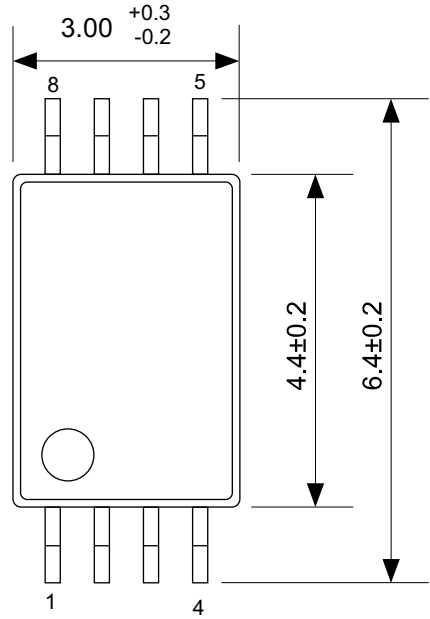

No. FT008-Z-P-SD-1.2

TITLE	TSSOP8-Z-PKG Dimensions
No.	FT008-Z-P-SD-1.2
ANGLE	
UNIT	mm

SII Semiconductor Corporation

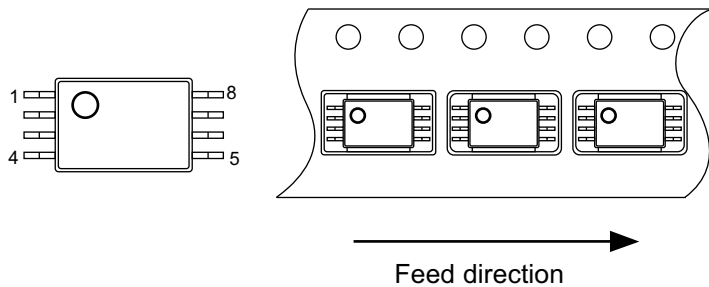
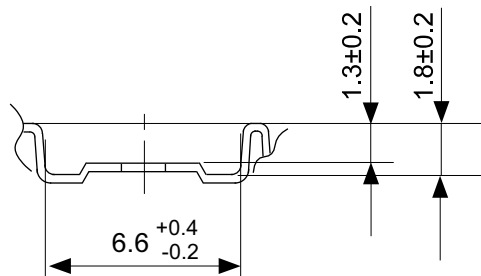
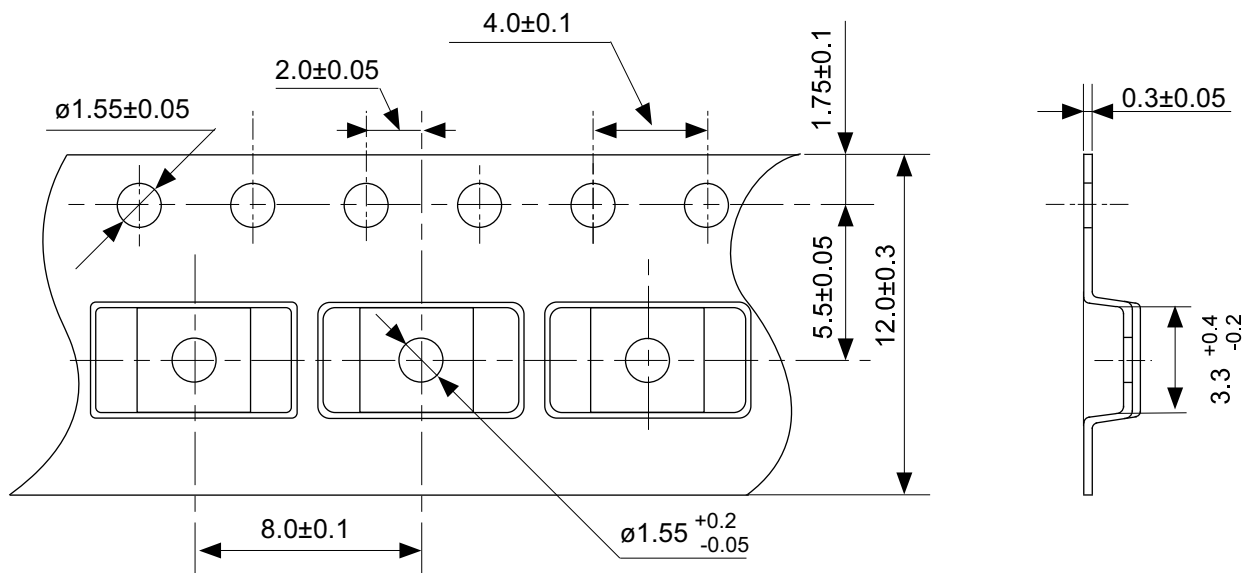

No. FT008-Z-C-SD-1.0

TITLE	TSSOP8-Z-Carrier Tape
No.	FT008-Z-C-SD-1.0
ANGLE	
UNIT	mm
SII Semiconductor Corporation	

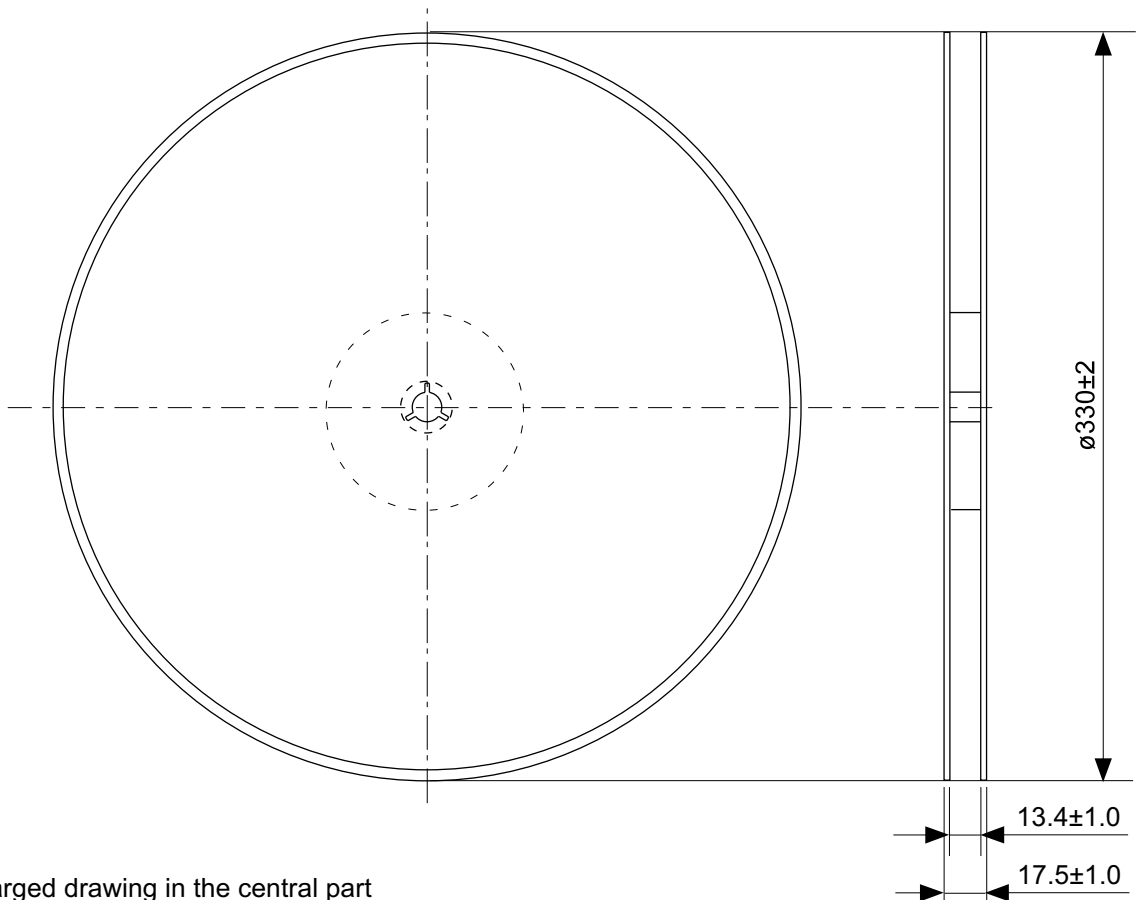

Enlarged drawing in the central part

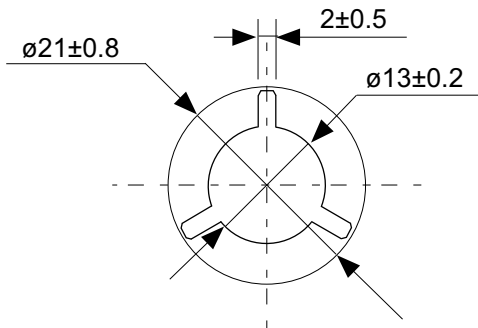

No. FT008-Z-R-SD-1.0

TITLE	TSSOP8-Z-Reel		
No.	FT008-Z-R-SD-1.0		
ANGLE		QTY.	4,000
UNIT	mm		
SII Semiconductor Corporation			

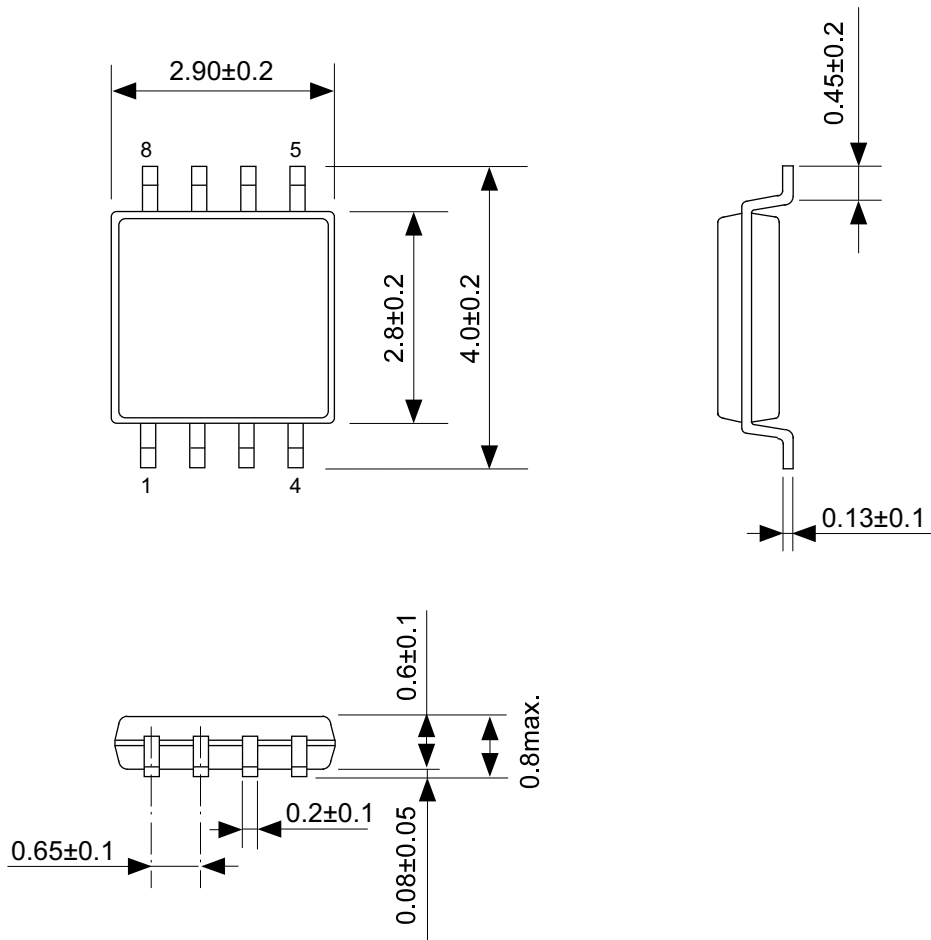

No. FM008-A-P-SD-1.2

TITLE	TMSOP8-A-PKG Dimensions
No.	FM008-A-P-SD-1.2
ANGLE	
UNIT	mm
SII Semiconductor Corporation	

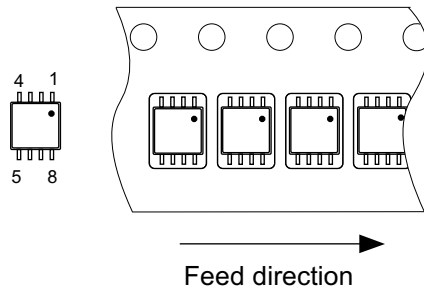
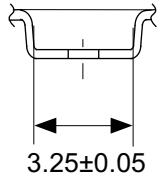
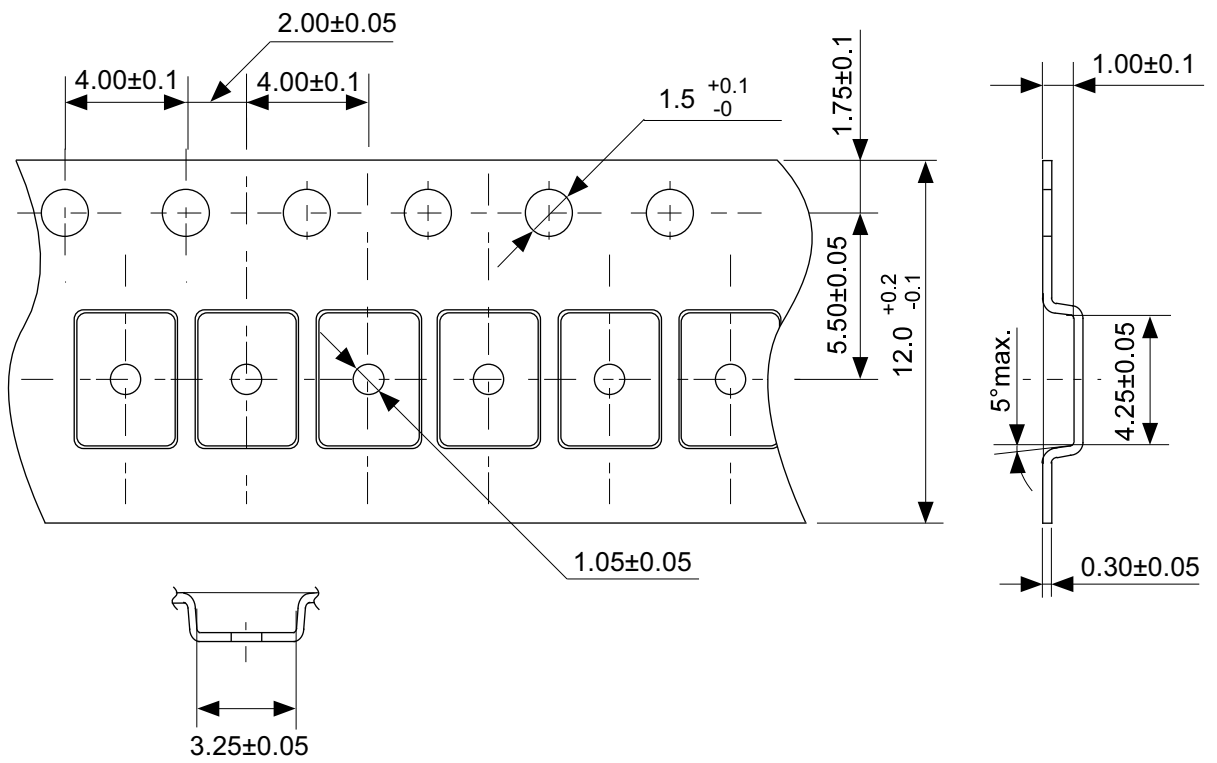

No. FM008-A-C-SD-2.0

TITLE	TMSOP8-A-Carrier Tape
No.	FM008-A-C-SD-2.0
ANGLE	
UNIT	mm
SII Semiconductor Corporation	

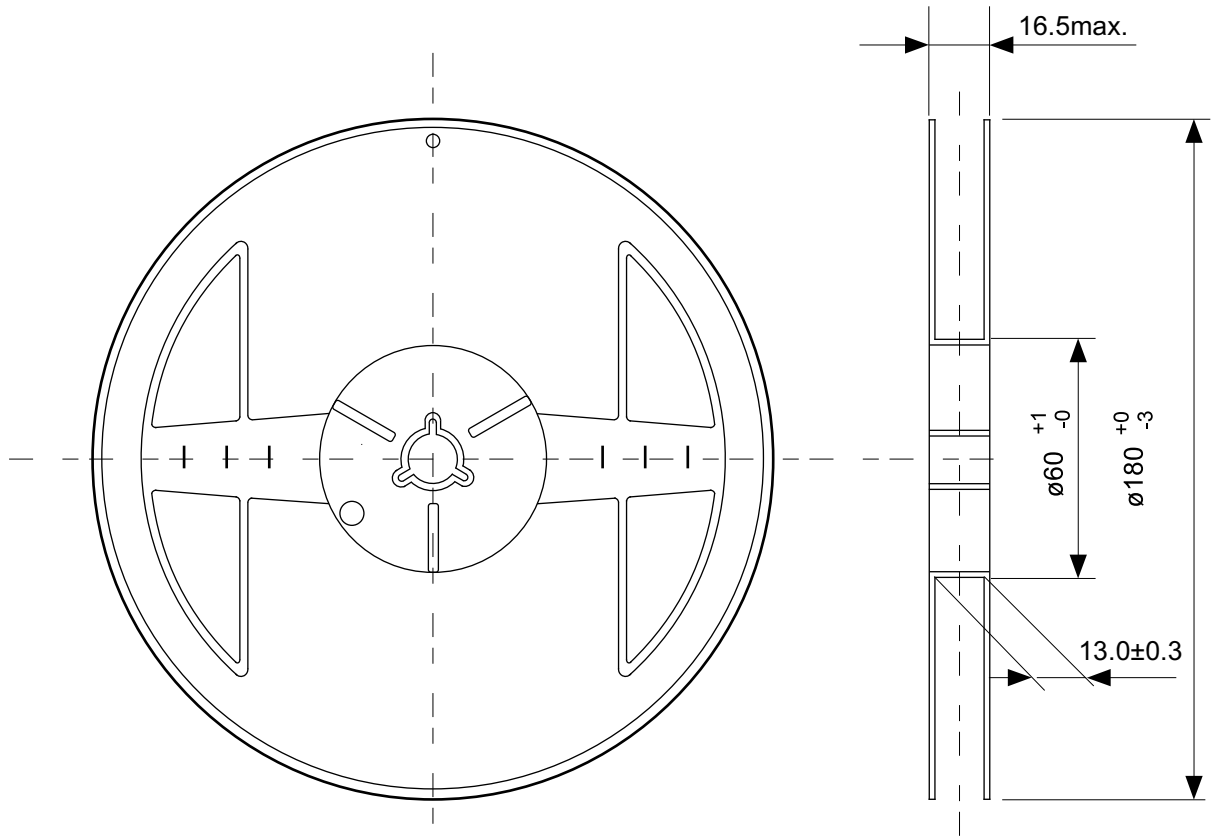

Enlarged drawing in the central part

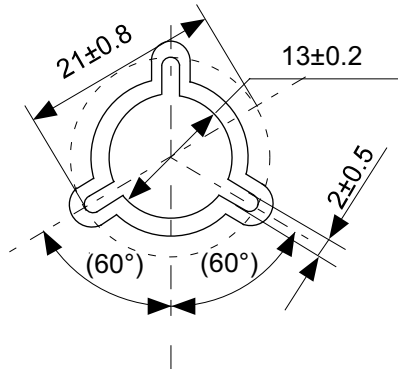

No. FM008-A-R-SD-1.0

TITLE	TMSOP8-A-Reel		
No.	FM008-A-R-SD-1.0		
ANGLE		QTY.	4,000
UNIT	mm		
SII Semiconductor Corporation			

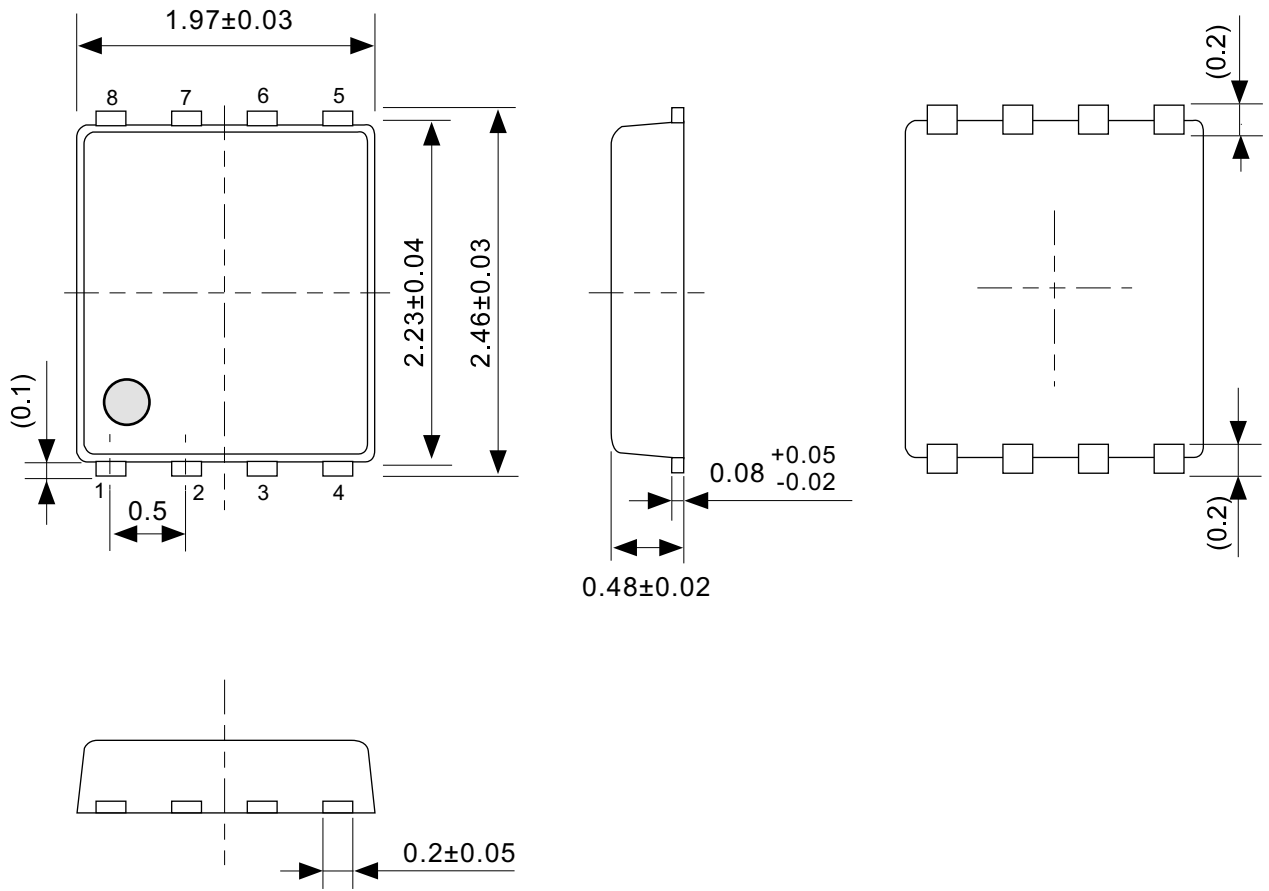

No. PH008-A-P-SD-2.1

TITLE	SNT-8A-A-PKG Dimensions
No.	PH008-A-P-SD-2.1
ANGLE	
UNIT	mm
SII Semiconductor Corporation	

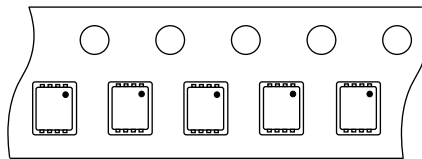
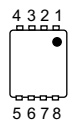
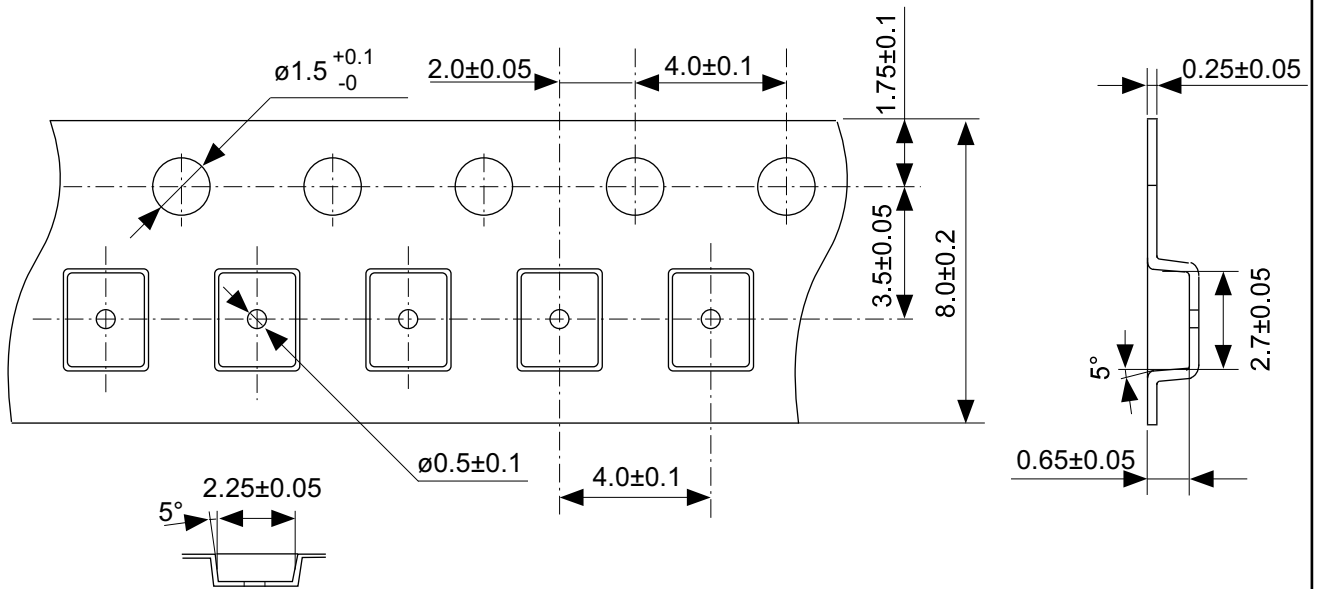

Feed direction

No. PH008-A-C-SD-1.0

TITLE	SNT-8A-A-Carrier Tape
No.	PH008-A-C-SD-1.0
ANGLE	
UNIT	mm
SII Semiconductor Corporation	

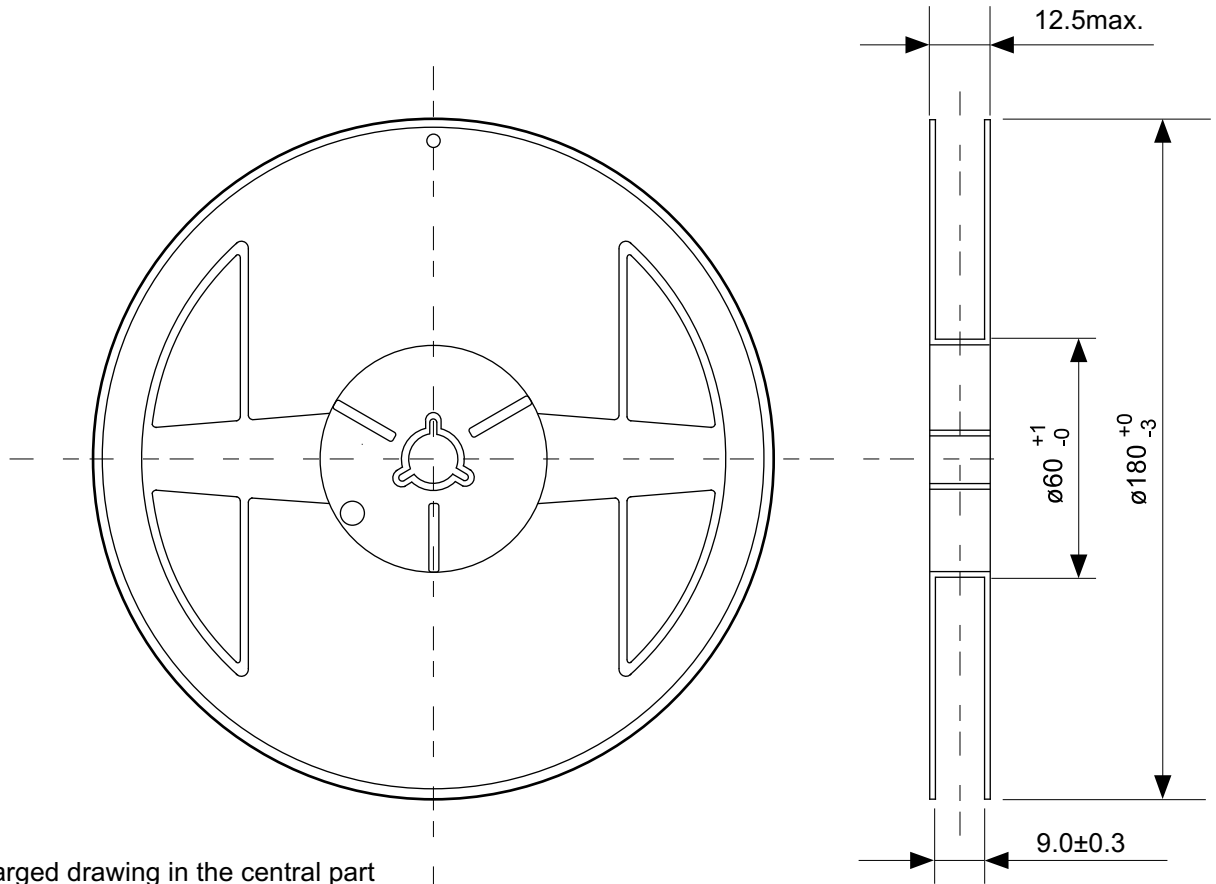

Enlarged drawing in the central part

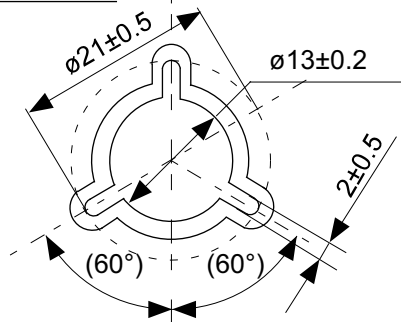

No. PH008-A-R-SD-1.0

TITLE	SNT-8A-A-Reel		
No.	PH008-A-R-SD-1.0		
ANGLE		QTY.	5,000
UNIT	mm		
SII Semiconductor Corporation			

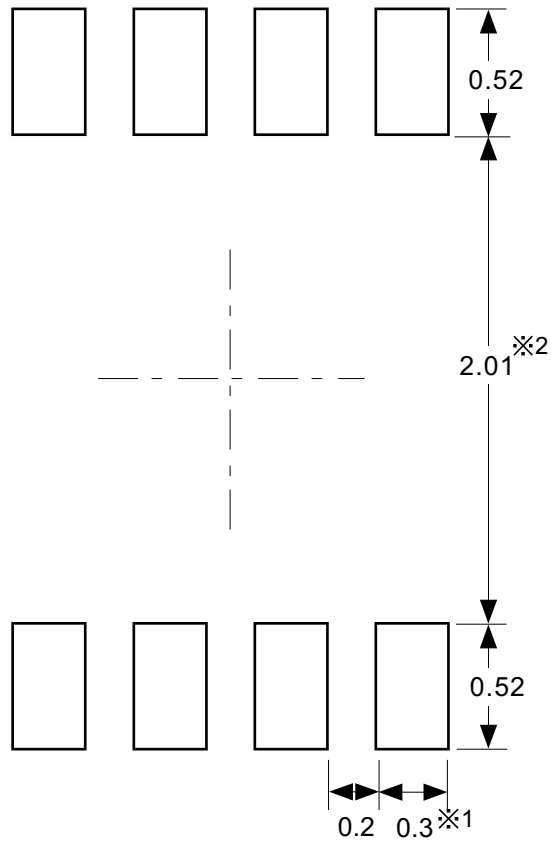

※1. ランドパターンの幅に注意してください (0.25 mm min. / 0.30 mm typ.).  
 ※2. パッケージ中央にランドパターンを広げないでください (1.96 mm ~ 2.06 mm)。

- 注意
1. パッケージのモールド樹脂下にシルク印刷やハンダ印刷などしないでください。
  2. パッケージ下の配線上のソルダーレジストなどの厚みをランドパターン表面から0.03 mm以下にしてください。
  3. マスク開口サイズと開口位置はランドパターンと合わせてください。
  4. 詳細は "SNTパッケージ活用の手引き" を参照してください。

※1. Pay attention to the land pattern width (0.25 mm min. / 0.30 mm typ.).  
 ※2. Do not widen the land pattern to the center of the package (1.96 mm to 2.06mm).

- Caution**
1. Do not do silkscreen printing and solder printing under the mold resin of the package.
  2. The thickness of the solder resist on the wire pattern under the package should be 0.03 mm or less from the land pattern surface.
  3. Match the mask aperture size and aperture position with the land pattern.
  4. Refer to "SNT Package User's Guide" for details.

※1. 请注意焊盘模式的宽度 (0.25 mm min. / 0.30 mm typ.).  
 ※2. 请勿向封装中间扩展焊盘模式 (1.96 mm ~ 2.06 mm)。

- 注意
1. 请勿在树脂型封装的下面印刷丝网、焊锡。
  2. 在封装下、布线上的阻焊膜厚度 (从焊盘模式表面起) 请控制在 0.03 mm 以下。
  3. 钢网的开口尺寸和开口位置请与焊盘模式对齐。
  4. 详细内容请参阅 "SNT 封装的应用指南"。

No. PH008-A-L-SD-4.1

TITLE	SNT-8A-A -Land Recommendation
No.	PH008-A-L-SD-4.1
ANGLE	
UNIT	mm
SII Semiconductor Corporation	

## Disclaimers (Handling Precautions)

1. All the information described herein (product data, specifications, figures, tables, programs, algorithms and application circuit examples, etc.) is current as of publishing date of this document and is subject to change without notice.
2. The circuit examples and the usages described herein are for reference only, and do not guarantee the success of any specific mass-production design.  
SII Semiconductor Corporation is not responsible for damages caused by the reasons other than the products or infringement of third-party intellectual property rights and any other rights due to the use of the information described herein.
3. SII Semiconductor Corporation is not responsible for damages caused by the incorrect information described herein.
4. Take care to use the products described herein within their specified ranges. Pay special attention to the absolute maximum ratings, operation voltage range and electrical characteristics, etc.  
SII Semiconductor Corporation is not responsible for damages caused by failures and/or accidents, etc. that occur due to the use of products outside their specified ranges.
5. When using the products described herein, confirm their applications, and the laws and regulations of the region or country where they are used and verify suitability, safety and other factors for the intended use.
6. When exporting the products described herein, comply with the Foreign Exchange and Foreign Trade Act and all other export-related laws, and follow the required procedures.
7. The products described herein must not be used or provided (exported) for the purposes of the development of weapons of mass destruction or military use. SII Semiconductor Corporation is not responsible for any provision (export) to those whose purpose is to develop, manufacture, use or store nuclear, biological or chemical weapons, missiles, or other military use.
8. The products described herein are not designed to be used as part of any device or equipment that may affect the human body, human life, or assets (such as medical equipment, disaster prevention systems, security systems, combustion control systems, infrastructure control systems, vehicle equipment, traffic systems, in-vehicle equipment, aviation equipment, aerospace equipment, and nuclear-related equipment), excluding when specified for in-vehicle use or other uses. Do not use those products without the prior written permission of SII Semiconductor Corporation. Especially, the products described herein cannot be used for life support devices, devices implanted in the human body and devices that directly affect human life, etc.  
Prior consultation with our sales office is required when considering the above uses.  
SII Semiconductor Corporation is not responsible for damages caused by unauthorized or unspecified use of our products.
9. Semiconductor products may fail or malfunction with some probability.  
The user of these products should therefore take responsibility to give thorough consideration to safety design including redundancy, fire spread prevention measures, and malfunction prevention to prevent accidents causing injury or death, fires and social damage, etc. that may ensue from the products' failure or malfunction.  
The entire system must be sufficiently evaluated and applied on customer's own responsibility.
10. The products described herein are not designed to be radiation-proof. The necessary radiation measures should be taken in the product design by the customer depending on the intended use.
11. The products described herein do not affect human health under normal use. However, they contain chemical substances and heavy metals and should therefore not be put in the mouth. The fracture surfaces of wafers and chips may be sharp. Take care when handling these with the bare hands to prevent injuries, etc.
12. When disposing of the products described herein, comply with the laws and ordinances of the country or region where they are used.
13. The information described herein contains copyright information and know-how of SII Semiconductor Corporation.  
The information described herein does not convey any license under any intellectual property rights or any other rights belonging to SII Semiconductor Corporation or a third party. Reproduction or copying of the information described herein for the purpose of disclosing it to a third-party without the express permission of SII Semiconductor Corporation is strictly prohibited.
14. For more details on the information described herein, contact our sales office.

1.0-2016.01

