

TIOL111 IO-Link Device Transceivers with Integrated Surge Protection

1 Features

- 7-V to 36-V Supply Voltage
- PNP, NPN or IO-Link Configurable Output
 - IEC 61131-9 COM1, COM2 and COM3 Data Rate Support
- Low Residual Voltage of 1.75 V at 250 mA
- 50-mA to 350-mA Configurable Current Limit
- Tolerant to ± 65 -V Transients < 100 μ s
- Reverse Polarity Protection of up to 55 V on L+, CQ and L-
- Integrated EMC Protection on L+ and CQ
 - ± 16 kV IEC 61000-4-2 ESD Contact Discharge
 - ± 4 kV IEC 61000-4-4 Electrical Fast Transient
 - ± 1.2 kV/500 Ω IEC 61000-4-5 Surge
- Fast Demagnetization of Inductive Loads up to 1.5 H
- Large Capacitive Load Driving Capability
- < 2 - μ A CQ Leakage Current
- < 1.5 -mA Quiescent Supply Current
- Integrated LDO Options for up to 20 mA Current
 - TIOL111: No LDO
 - TIOL111-3: 3.3-V LDO
 - TIOL111-5: 5-V LDO
- Overtemperature Warning and Thermal Protection
- Remote Wake-up Indicator
- Fault Indicator
- Extended Ambient Temperature: -40°C to 125°C
- 2.5 mm x 3 mm 10-pin VSON Package

2 Applications

- IO-Link Sensors and Actuators
- Factory Automation
- Process Automation

3 Description

The TIOL111 family of transceivers implements the IO-Link interface for industrial bidirectional, point-to-point communication. When the device is connected to an IO-Link master through a three-wire interface, the master can initiate communication and exchange data with the remote node while the TIOL111 acts as a complete physical layer for the communication.

These devices are capable of withstanding up to 1.2 kV (500 Ω) of IEC 61000-4-5 surge and feature integrated reverse polarity protection.

A simple pin-programmable interface allows easy interfacing to the controller circuits. The output current limit can be configured using an external resistor.

Fault reporting and internal protection functions are provided for under voltage, over current and over temperature conditions.

Device Information⁽¹⁾

PART NUMBER	PACKAGE	BODY SIZE (NOM)
TIOL111	VSON (10)	2.50 mm x 3.00 mm
TIOL111-3		
TIOL111-5		

(1) For all available devices, see the orderable addendum at the end of the data sheet.

Typical Application Diagram

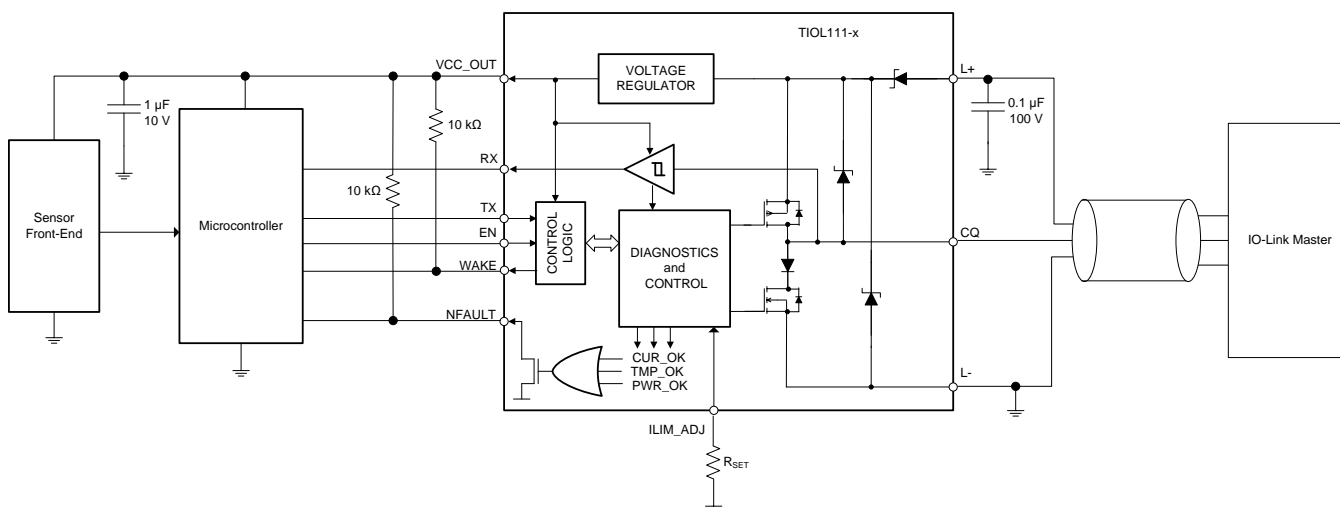

Copyright © 2017, Texas Instruments Incorporated



Table of Contents

1 Features	1	8.3 Feature Description.....	12
2 Applications	1	8.4 Device Functional Modes.....	17
3 Description	1	9 Application and Implementation	19
4 Revision History	2	9.1 Application Information.....	19
5 Pin Configuration and Functions	3	9.2 Typical Application	19
6 Specifications	4	10 Power Supply Recommendations	23
6.1 Absolute Maximum Ratings	4	11 Layout	24
6.2 ESD Ratings.....	4	11.1 Layout Guidelines	24
6.3 Recommended Operating Conditions	4	11.2 Layout Example	24
6.4 Thermal Information	5	12 Device and Documentation Support	25
6.5 Electrical Characteristics.....	5	12.1 Receiving Notification of Documentation Updates	25
6.6 Switching Characteristics	7	12.2 Community Resources.....	25
6.7 Typical Characteristics	8	12.3 Trademarks	25
7 Parameter Measurement Information	9	12.4 Electrostatic Discharge Caution.....	25
8 Detailed Description	11	12.5 Glossary	25
8.1 Overview	11	13 Mechanical, Packaging, and Orderable	
8.2 Functional Block Diagrams	11	Information	25

4 Revision History

DATE	REVISION	NOTES
July 2017	*	Initial release.

5 Pin Configuration and Functions

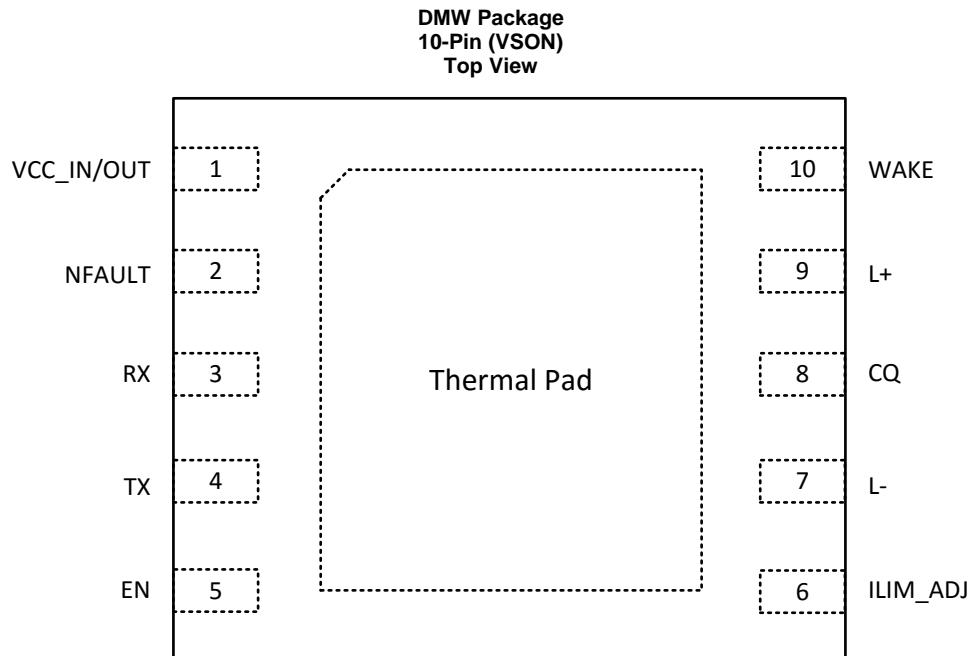

Pin Functions

PIN		I/O	DESCRIPTION
NAME	NO.		
IO-Link Interface			
CQ	8	I/O	IO-Link data signal (bidirectional)
L+	9	POWER	IO-Link supply voltage (24 V nominal)
L-	7	POWER	IO-Link ground potential
Local Controller Interface			
EN	5	I	Driver enable input signal from the local controller. Logic low sets the CQ output at Hi-Z. Weak internal pull-down.
WAKE	10	OPEN-DRAIN	Wake up indicator to the local controller. Connect this pin via pull-up resistor to VCC_IN/OUT.
RX	3	O	Receive data output to the local controller
TX	4	I	Transmit data input from the local controller. No effect if EN is low. Logic high sets low-side switch. Logic low sets high-side switch. Weak internal pull-up.
Thermal Pad	—	—	Connect to L- for optimal thermal and electrical performance
Internal LDO			
VCC_IN/OUT	1	POWER	3.3-V or 5-V linear regulator output; external 3.3-V or 5-V logic supply for option without LDO.
Special Connect Pins			
ILIM_ADJ	6	I	Input for current limit adjustment. Connect resistor R_{SET} between ILIM_ADJ and L-.
NFAULT	2	OPEN-DRAIN	Fault indicator output signal to the microcontroller. A low level indicates either an over-current, an undervoltage supply or an overtemperature condition.

6 Specifications

6.1 Absolute Maximum Ratings

over operating free-air temperature range (unless otherwise noted)⁽¹⁾

		MIN	MAX	UNIT
Supply voltage	Steady state voltage for L+ and CQ	-55	55	V
	Transient pulse width < 100 μ s for L+ and CQ	-65	65	V
Voltage difference	$ V_{(L+)} - V_{(CQ)} $		55	V
Logic supply voltage (TIOL111)	VCC_IN	-0.3	6	V
Input logic voltage	TX, EN, ILIM_ADJ	-0.3	6	V
Output current	RX, WAKE, NFAULT	-5	5	mA
Storage temperature, T _{stg}		-55	170	°C

- (1) Stresses beyond those listed under *Absolute Maximum Ratings* may cause permanent damage to the device. These are stress ratings only, which do not imply functional operation of the device at these or any other conditions beyond those indicated under *Recommended Operating Conditions*. Exposure to absolute-maximum-rated conditions for extended periods may affect device reliability. All voltages are with reference to the L- pin, unless otherwise specified.

6.2 ESD Ratings

			VALUE	UNIT	
V _(ESD)	Electrostatic discharge	Human-body model (HBM), per ANSI/ESDA/JEDEC JS-001 ⁽¹⁾	All pins	±4000	V
		Contact discharge, per IEC 61000-4-2 ⁽²⁾⁽³⁾		±16000	
		Electrical fast transient, per IEC 61000-4-4 ⁽²⁾	Pins L+, CQ and L-	±4000	
		Surge protection with 500 Ω , per IEC 61000-4-5; 1.2/50 μ s ⁽²⁾		±1200	

- (1) JEDEC document JEP155 states that 500-V HBM allows safe manufacturing with a standard ESD control process.
 (2) Minimum 100-nF capacitor is required between L+ and L-. Minimum 1- μ F capacitor is required between VCC_IN/OUT and L-.
 (3) Passing level is \pm 4500 V if the device is powered and EN=TX=HIGH.

6.3 Recommended Operating Conditions

over operating free-air temperature range (unless otherwise noted)

		MIN	NOM	MAX	UNIT
V _(L+)	Supply voltage	7	24	36	V
V _(VCC_IN)	Logic level input voltage (TIOL111 only)	3.3 V configuration	3.3	3.6	V
		5 V configuration	4.5	5.5	V
R _{SET}	External resistor for CQ current limit	0		100	k Ω
1/t _{BIT}	Data rate (Communication mode)			250	kbps
I _(VCC_OUT)	LDO output current (TIOL111-3 and TIOL111-5 only)			20	mA
T _A	Operating ambient temperature	-40		125	°C
T _J	Junction temperature			150	°C

6.4 Thermal Information

THERMAL METRIC ⁽¹⁾		TIOL111	UNIT
		DMW (10 Pins)	
R _{θJA}	Junction-to-ambient thermal resistance	68.1	°C/W
R _{θJC(top)}	Junction-to-case (top) thermal resistance	60.1	°C/W
R _{θJB}	Junction-to-board thermal resistance	40.6	°C/W
ψ _{JT}	Junction-to-top characterization parameter	13.4	°C/W
ψ _{JB}	Junction-to-board characterization parameter	40.7	°C/W
R _{θJC(bot)}	Junction-to-case (bottom) thermal resistance	25.2	°C/W

(1) For more information about traditional and new thermal metrics, see the [Semiconductor and IC Package Thermal Metrics](#) application report.

6.5 Electrical Characteristics

over operating free-air temperature range (unless otherwise noted)

PARAMETER		TEST CONDITIONS	MIN	TYP	MAX	UNIT
POWER SUPPLIES (L+)						
I _{L+}	Quiescent supply current	EN = LOW, no load		1	1.5	mA
		EN = HIGH, no load		2	2.7	mA
LOGIC-LEVEL INPUTS (EN, TX)						
V _{IL}	Input logic low voltage				0.8	V
V _{IH}	Input logic high voltage		2			V
R _{PD}	Pull-down (EN) resistance			100		kΩ
R _{PU}	Pull-up (TX) resistance			200		kΩ
CONTROL OUTPUTS (WAKE, NFAULT)						
V _{OL}	Output logic low voltage	I _O = 4 mA			0.5	V
I _{OZ}	Output high impedance leakage	Output in Hi-Z, V _O = 0 V or VCC_IN/OUT	-1		1	μA
DRIVER OUTPUT (CQ)						
V _{DS(ON)}	High-side driver residual voltage	I = 250 mA			1.75	V
		I = 200 mA			1.5	V
		I = 100 mA			1.1	V
	Low-side driver residual voltage	I = 250 mA			1.75	V
		I = 200 mA			1.5	V
		I = 100 mA			1.1	V
I _{OZ}	CQ leakage	EN = LOW, 0 ≤ V _(CQ) ≤ (V _(L+) - 0.1 V)	-2		2	μA
I _{O(LIM)}	Driver output current limit	R _{SET} = 100 kΩ	35	50	70	mA
		R _{SET} = 0 kΩ	300	350	400	mA
		R _{SET} = OPEN ⁽¹⁾	300	350	400	mA
RECEIVER INPUT (CQ)						
V _(THH)	Input threshold "H"	V _(L+) > 18 V	10.5		13	V
V _(THL)	Input threshold "L"		8		11.5	V
V _(HYS)	Receiver Hysteresis (V _(THH) - V _(THL))		0.75			V
V _(THH)	Input threshold "H"	V _(L+) < 18 V	See Note ⁽²⁾		See Note ⁽³⁾	V
V _(THL)	Input threshold "L"		See Note ⁽⁴⁾		See Note ⁽⁵⁾	V
V _(HYS)	Receiver Hysteresis (V _(THH) - V _(THL))		0.75			V
V _{OL}	RX output low voltage	I _{OL} = 4 mA			0.4	V
V _{OH}	RX output high voltage	I _{OL} = -4 mA		VCC_IN/ OUT-0.5		V

(1) Current fault indication will be active. Current fault auto recovery will be de-activated.

(2) V_{THH} (min) = 5 V + (11/18) [V_(L+) - 8 V]

(3) V_{THH} (max) = 6.5 V + (13/18) [V_(L+) - 8 V]

(4) V_{THL} (min) = 4 V + (8/18) [V_(L+) - 8 V]

(5) V_{THL} (max) = 6 V + (11/18) [V_(L+) - 8 V]

Electrical Characteristics (continued)

over operating free-air temperature range (unless otherwise noted)

PARAMETER		TEST CONDITIONS	MIN	TYP	MAX	UNIT
PROTECTION CIRCUITS						
$V_{(UVLO)}$	L+ under voltage lockout	L+ falling; NFAULT = Hi-Z			6	V
		L+ rising; NFAULT = LOW			6.5	V
$V_{(UVLO,HYS)}$	L+ under voltage hysteresis	Rising to falling threshold	100			mV
$V_{(UVLO,IN)}$	VCC_IN under voltage lockout (No LDO option)	VCC_IN falling; NFAULT = Hi-Z		2.4		V
		VCC_IN rising; NFAULT = LOW		2.5		V
$V_{(UVLO,HYS)}$	VCC_IN under voltage hysteresis (No LDO option)	Rising to falling threshold		100		mV
$T_{(WRN)}$	Thermal warning	Die temperature T_J	125			°C
$T_{(SDN)}$	Thermal shutdown		150	160		°C
$T_{(HYS)}$	Thermal hysteresis for shutdown		10			°C
I_{REV}	Leakage current in reverse polarity	EN = LOW, TX=x; $V_{(CQ)} < V_{(L-)}$ or $V_{(CQ)} > V_{(L+)}$, up to 36 V			50	μA
		EN = LOW, TX=x; $V_{(CQ)} < V_{(L-)}$ or $V_{(CQ)} > V_{(L+)}$, up to 55 V			80	μA
		EN = HIGH, TX = LOW; $V_{(CQ \text{ to } L+)} = 3 \text{ V}$			550	μA
		EN = HIGH, TX = HIGH; $V_{(CQ \text{ to } L-)} = -3 \text{ V}$			10	μA
LINEAR REGULATOR (LDO)						
$V_{(VCC_OUT)}$	Voltage regulator output	TIOL111-5	4.75	5	5.25	V
		TIOL111-3	3.13	3.3	3.46	V
$V_{(DROP)}$	Voltage regulator drop-out voltage ($V_{(L+)} - V_{(VCC_OUT)}$)	$I_{CC} = 20 \text{ mA}$ load current	TIOL111-5		1.9	V
			TIOL111-3		2.3	V
REG	Line regulation ($dV_{(VCC_OUT)}/dV_{(L+)}$)	$I_{(VCC_OUT)} = 1 \text{ mA}$			1.7	mV/V
L_{REG}	Load regulation ($dV_{(VCC_OUT)}/V_{(VCC_OUT)}$)	$V_{(L+)} = 24 \text{ V}$, $I_{(VCC_OUT)} = 100 \text{ μA}$ to 20 mA			1%	
PSSR	Power Supply Rejection Ratio	100 kHz, $I_{(VCC_OUT)} = 20 \text{ mA}$		40		dB

6.6 Switching Characteristics

over operating free-air temperature range (unless otherwise noted)

PARAMETER		TEST CONDITIONS	MIN	TYP	MAX	UNIT
SECTION NAME						
t_{PLH}, t_{PHL}	Driver propagation delay	See Figure 6 See Figure 7 See Figure 8 $R_L = 2\text{ k}\Omega$ $C_L = 5\text{ nF}$ $R_{(SET)} = 0\ \Omega$		600	800	ns
$t_{P(skew)}$	Driver propagation delay skew. $ t_{PLH} - t_{PHL} $			100		ns
t_{PZH}, t_{PZL}	Driver enable delay					4 μs
t_{PHZ}, t_{PLZ}	Driver disable delay					4 μs
t_r, t_f	Driver output rise, fall time					150 ns
$ t_r - t_f $	Difference in rise and fall time					50 ns
t_{WU1}	Wake-up recognition begin	See Figure 10	45	60	75	μs
t_{WU2}	Wake-up recognition end		85	100	135	μs
t_{PWAKE}	Wake-up output delay				140	μs
t_{SC}	Current fault blanking time		175	200		μs
t_{pSC}	Current fault indication delay				260	μs
t_{SCEN}	Current fault driver re-enable wait time			15		ms
$t_{(UVLO)}$	CQ re-enable delay after UVLO ⁽¹⁾	$V_{(UVLO)}$ rising threshold crossing time to CQ enable time	10	30	50	ms
RECEIVER						
t_{ND}	Noise suppression time ⁽²⁾				250	ns
t_{PLH}, t_{PHL}	Receiver propagation delay	See Figure 9 15-pF load on RX		150	300	ns

(1) CQ output remains Hi-Z for this time

(2) Noise suppression time is defined as the permissible duration of a receive signal above/below the detection threshold without detection taking place.

6.7 Typical Characteristics

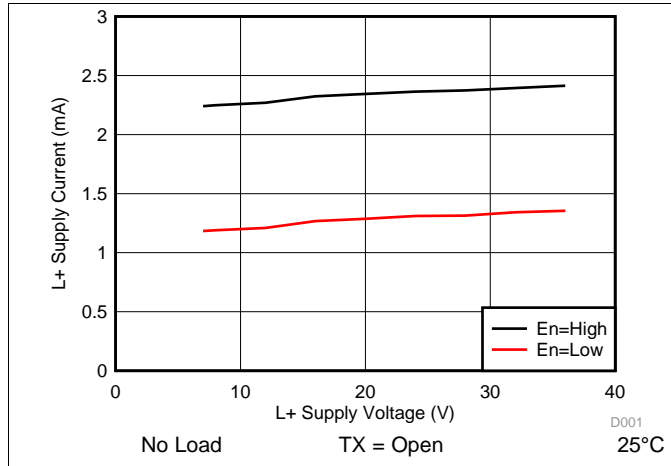

Figure 1. Supply Current vs Supply Voltage

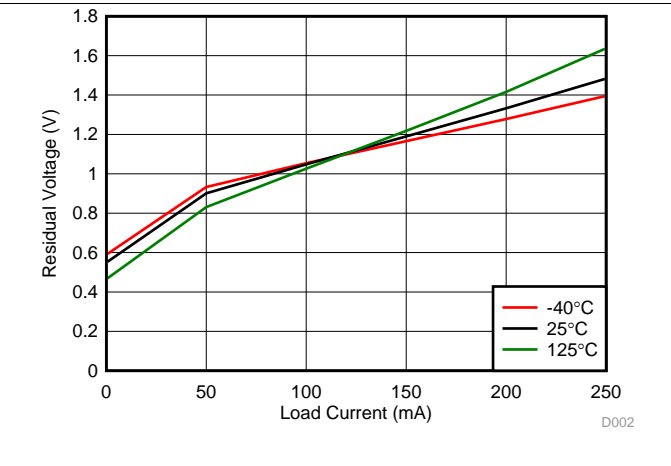

Figure 2. Residual Voltage vs Load Current: High Side

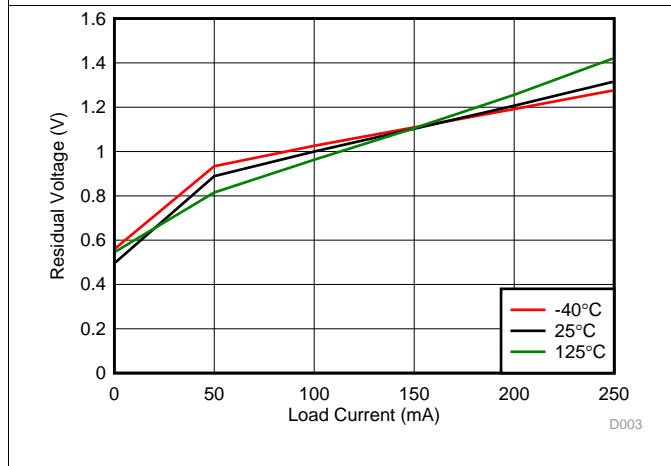

Figure 3. Residual Voltage vs Load Current: Low Side

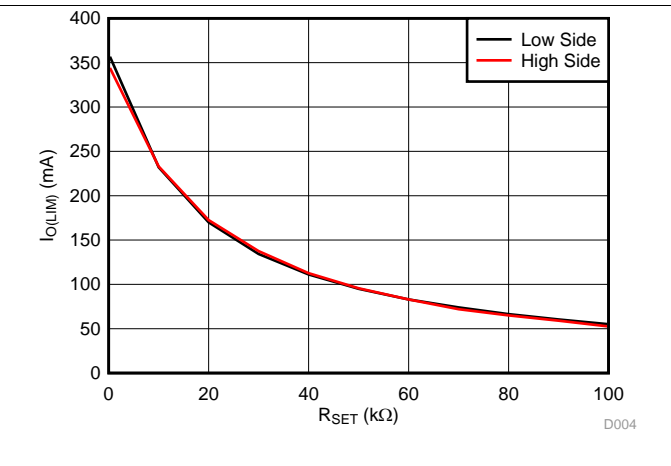

Figure 4. Current Limit vs RSET

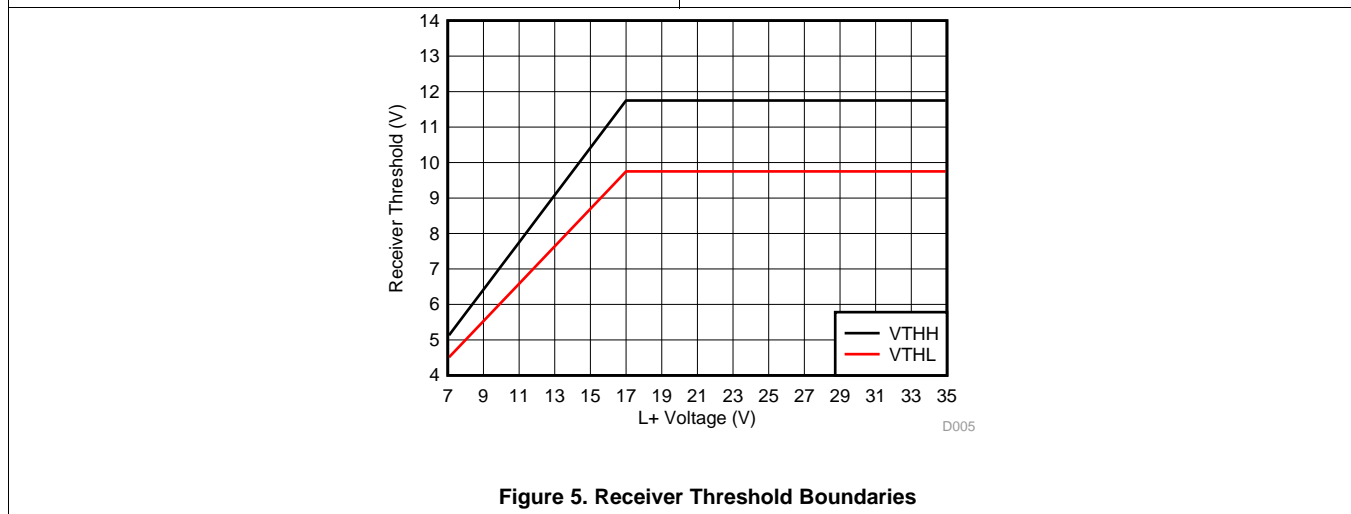
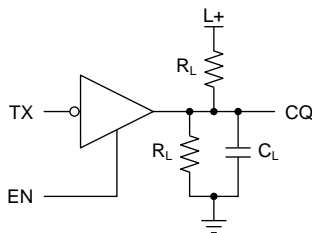

Figure 5. Receiver Threshold Boundaries

7 Parameter Measurement Information



Copyright © 2016, Texas Instruments Incorporated

Figure 6. Test Circuit for Driver Switching

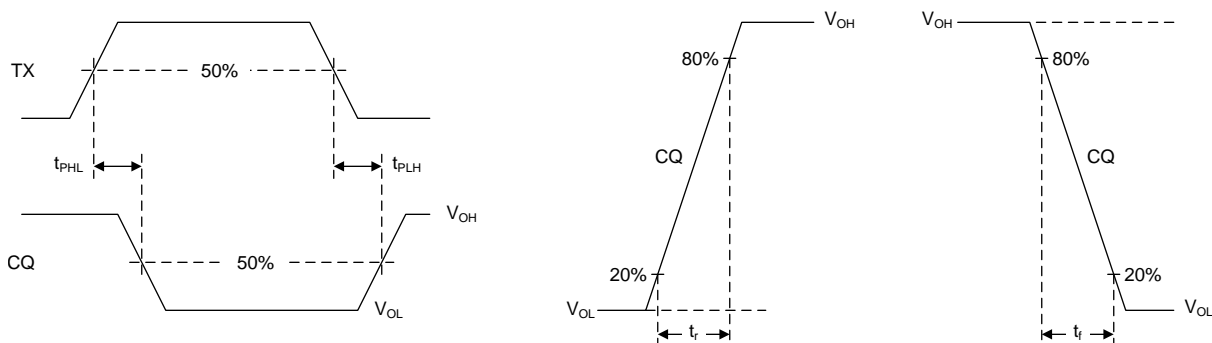

Figure 7. Waveforms for Driver Output Switching Measurements

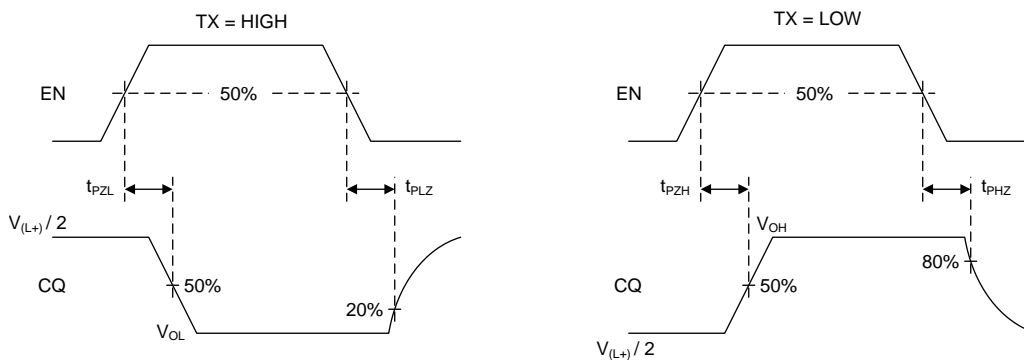

Figure 8. Waveforms for Driver Enable/Disable Time Measurements

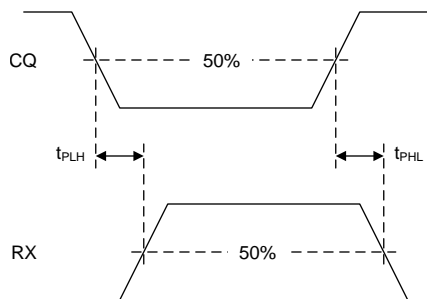

Figure 9. Receiver Switching Measurements

Parameter Measurement Information (continued)

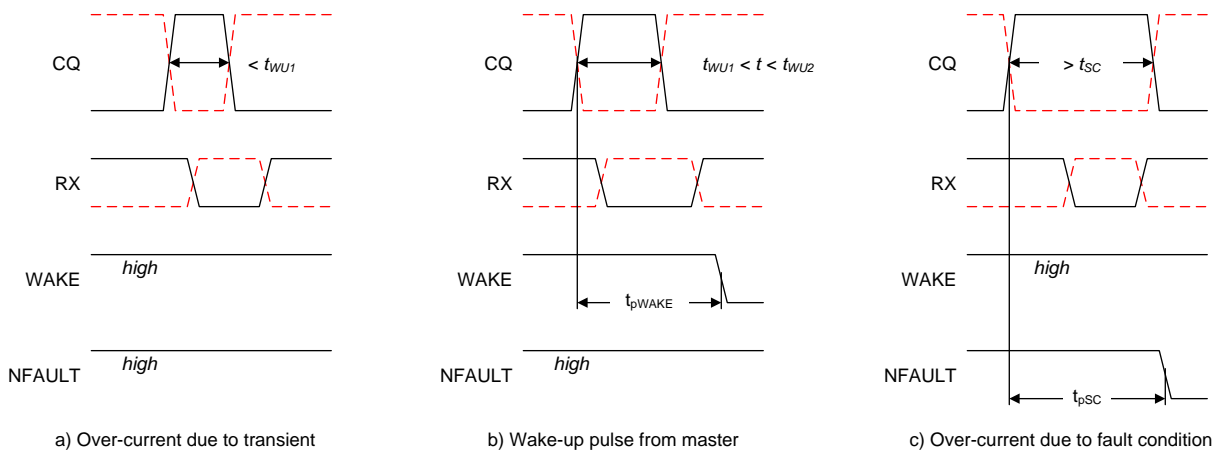

Figure 10. Overcurrent and Wake Conditions for EN = H, TX = H (Full Lines); and TX = L (Red Dotted Lines)

8 Detailed Description

8.1 Overview

Figure 11 shows that the TIOL111 or TIOL111-x driver output (CQ) can be used in either push-pull, high-side, or low-side configuration using the enable (EN) and transmit data (TX) input pins. The internal receiver converts the 24-V signal on the CQ line to standard logic levels on the receive data (RX) pin. A simple parallel interface is used to receive/transmit data and status information between the slave and the local controller.

These devices have integrated IEC 61000-4-4/5 EFT and surge protection. In addition, tolerance to ± 65 -V transients enables flexibility to choose from a wider range of TVS diodes if an application requires higher levels of protection. These integrated robustness features will simplify the system level design by reducing external protection circuitry.

TIOL111 or TIOL111-x transceivers implement protection features for overcurrent, overvoltage and over-temperature conditions. The devices also provide a current-limit setting of the driver output current using an external resistor.

The devices derive the low-voltage supply from the IO-Link L+ voltage (24 V nominal) via an internal linear regulator to provide power to the local controller and sensor circuitry.

8.2 Functional Block Diagrams

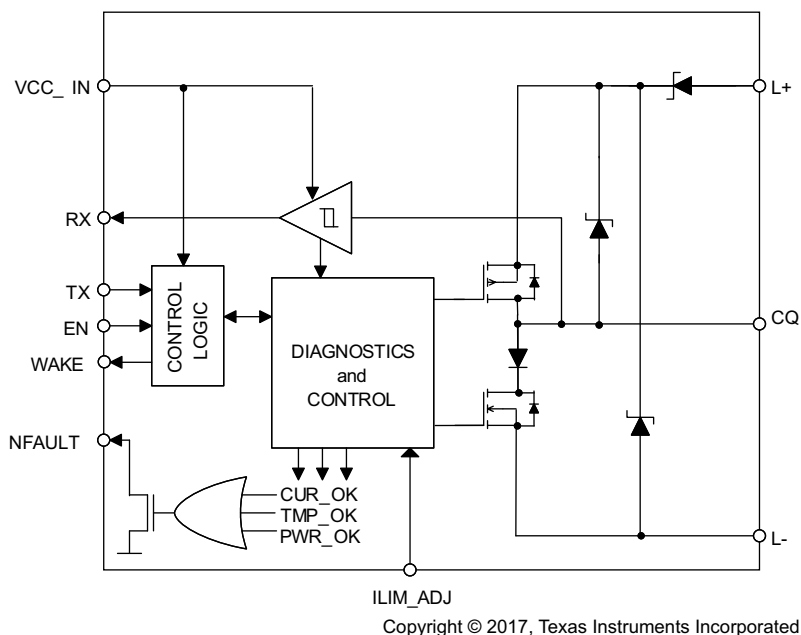

Figure 11. Block Diagram TIOL111

Functional Block Diagrams (continued)

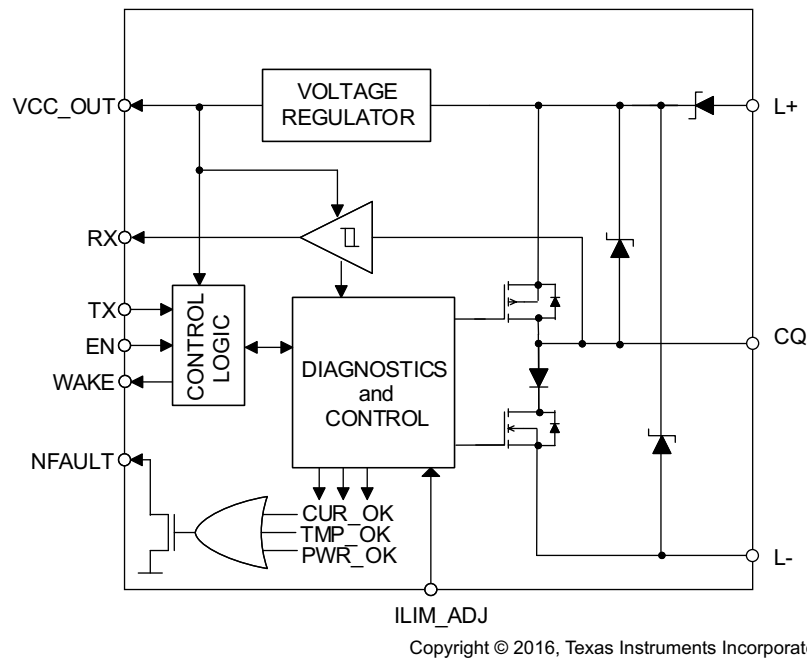

Figure 12. Block Diagram TIOL111-x

8.3 Feature Description

8.3.1 Wake Up Detection

The TIOL111 may be operated in IO-Link mode or Standard Input / Output (SIO) mode. If the device is in SIO mode and the master node wants to initiate communication with the device node, the master drives the CQ line to the opposite of its present state, and will either sink or source the wake up current (≥ 500 mA) for the wake-up duration (typically 80 μ s) depending on the CQ logic level as per the IO-Link specification. The TIOL111 detects this wake-up condition and communicates to the local microcontroller via the WAKE pin. The IO-Link communication specification requires the device node to switch to receive mode within 500 μ s after receiving the wake-up signal.

For overcurrent conditions shorter or longer than a valid wake-up pulse, the WAKE pin remains in a high-impedance (inactive) state. This is illustrated in [Figure 10](#).

8.3.2 Current Limit Configuration

The output current can be configured with an external resistor on ILIM_ADJ pin. The maximum settable current limit is 300 mA. This maximum setting specifies a minimum of 300 mA over temperature and voltage.

Output disable due to current fault and current fault auto recovery features can be disabled by floating ILIM_ADJ pin. However, the current fault indication is still active in this configuration. This feature is useful when driving large capacitances.

Table 1. Current Limit Configuration

ILIM_ADJ Pin Condition	CQ Current Limit	NFAULT Indication During Fault	Output Disable and Auto Recovery
R _{SET} resistor to L-	Variable	Yes	Yes
Connected to L-	300 mA	Yes	Yes
OPEN	300 mA	Yes	No

8.3.3 Current Fault Detection, Indication and Auto Recovery

If the output current at CQ exceeds the internally-set current limit $I_{O(LIM)}$ for a duration longer than t_{SC} , the NFAULT pin is driven logic low to indicate a fault condition. The output is turned off, but the LDO continues to function. The output periodically retries to check if the output is still in the over current condition. In this mode, the output is switched on for t_{SC} in t_{SCEN} intervals. Current fault auto recovery mode can be disabled by setting ILIM_ADJ = OPEN. See Table 5. Toggling EN will clear NFAULT.

8.3.4 Thermal Warning, Thermal Shutdown

If the die temperature exceeds $T_{(WRN)}$, the NFAULT flag is held low indicating a potential over temperature problem. When the T_J exceeds $T_{(SDN)}$, The output is disabled but the LDO remains operational. As soon as the temperature drops below the temperature threshold (and after $T_{(HYS)}$), the internal circuit re-enables the driver, subject to the state of the EN and TX pins.

8.3.5 Fault Reporting (NFAULT)

NFAULT is driven low if either a current fault condition is detected, die temperature has exceeded $T_{(WRN)}$ or supply has dropped below the UVLO threshold. NFAULT returns to high-impedance as soon as all three fault conditions clear.

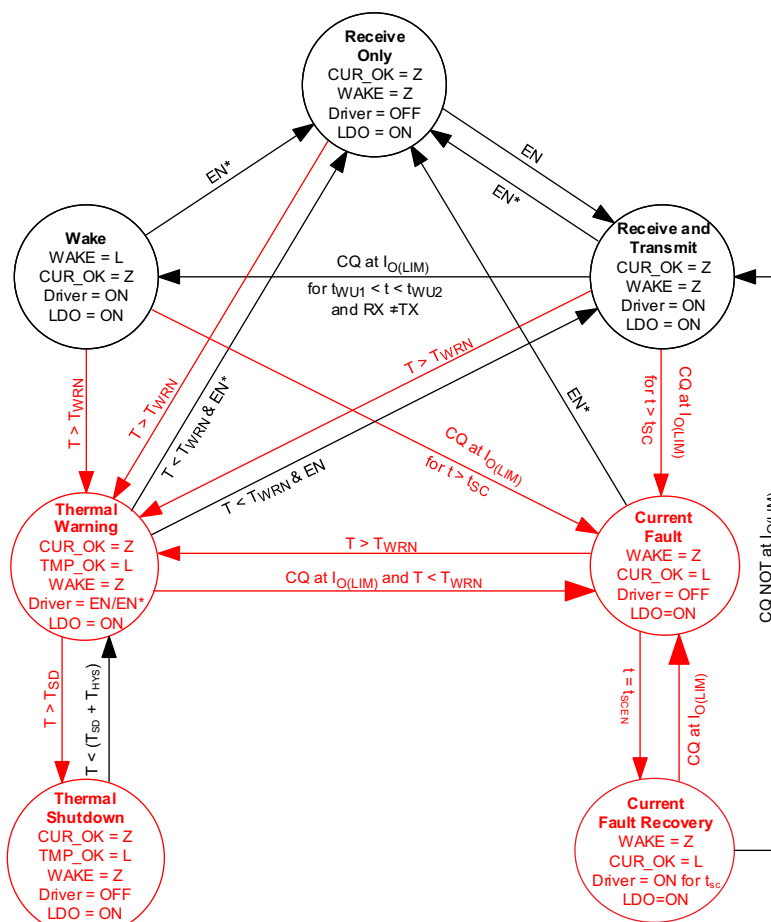

$$NFAULT = [CUR_OK \&\& PWR_OK \&\& TMP_OK]$$

Figure 13. Device State Diagram

8.3.6 Transceiver Function Tables

Table 2. Driver Function

EN	TX	CQ	COMMENT
L / Open	X	Hi-Z	Device is in ready-to-receive state
H	L	H	CQ is sourcing current (high-side drive)
H	H / Open	L	CQ is sinking current (low-side drive)

Table 3. Receiver Function

CQ VOLTAGE	RX	COMMENT
$V_{(CQ)} < V_{(THL)}$	H	Normal receive mode, input low
$V_{(THL)} < V_{(CQ)} < V_{(THH)}$?	Indeterminate output, may be either high or low
$V_{(THH)} < V_{(CQ)}$	L	Normal receive mode, input high
Open	?	Indeterminate output, may be either high or low

Table 4. Wake-Up Function ($t_{WU1} < t < t_{WU2}$)

EN	TX	CQ CURRENT	WAKE	COMMENT
L / Open	X	X	Z	Device is in ready-to-receive state
H	H / Open	$ I_{(CQ)} \geq 500 \text{ mA}$	L	Device receives high-level wake-up request from IO-Link Master
H	L	$ I_{(CQ)} \geq 500 \text{ mA}$	L	Device receives low-level wake-up request from IO-Link Master

Table 5. Current Limit Indicator Function ($t > t_{SC}$)

EN	TX	CQ CURRENT	NFAULT	COMMENT
H	H / Open	$ I_{(CQ)} > I_{O(LIM)}$	L	CQ current exceeds the set limit for over t_{SC}
		$ I_{(CQ)} < I_{O(LIM)}$	Z	Normal operation
H	L	$ I_{(CQ)} > I_{O(LIM)}$	L	CQ current exceeds the set limit for over t_{SC}
		$ I_{(CQ)} < I_{O(LIM)}$	Z	Normal operation
L / Open	X	X	Z	Driver is disabled, Current limit indicator is inactive

8.3.7 The Integrated Voltage Regulator (LDO)

The TIOL111-3 and TIOL111-5 each have an integrated linear voltage regulator (LDO) which can supply power to external components. The voltage regulator is specified for L+ voltages in the range of 7 V to 36 V with respect to L-. The LDO is capable of delivering up to 20 mA.

The LDO is designed to be stable with standard ceramic capacitors with values of 1 μF or larger at the output. X5R- and X7R-type capacitors are best because they have minimal variation in value and ESR over temperature. Maximum ESR should be less than 1 Ω . With tolerance and dc bias effects, the minimum capacitance to ensure stability is 1 μF .

The voltage regulator has an internal 35-mA current limit to protect against initial startup inrush current due to large decoupling capacitors and accidental short circuit conditions.

8.3.8 Reverse Polarity Protection

Reverse polarity protection circuitry protects the devices against accidental reverse polarity connections to the L+, CQ and L- pins. The maximum voltage between any of the pins may not exceed 55 V DC at any time.

[Figure 14](#) and [Figure 15](#) shows all the possible connection combinations.

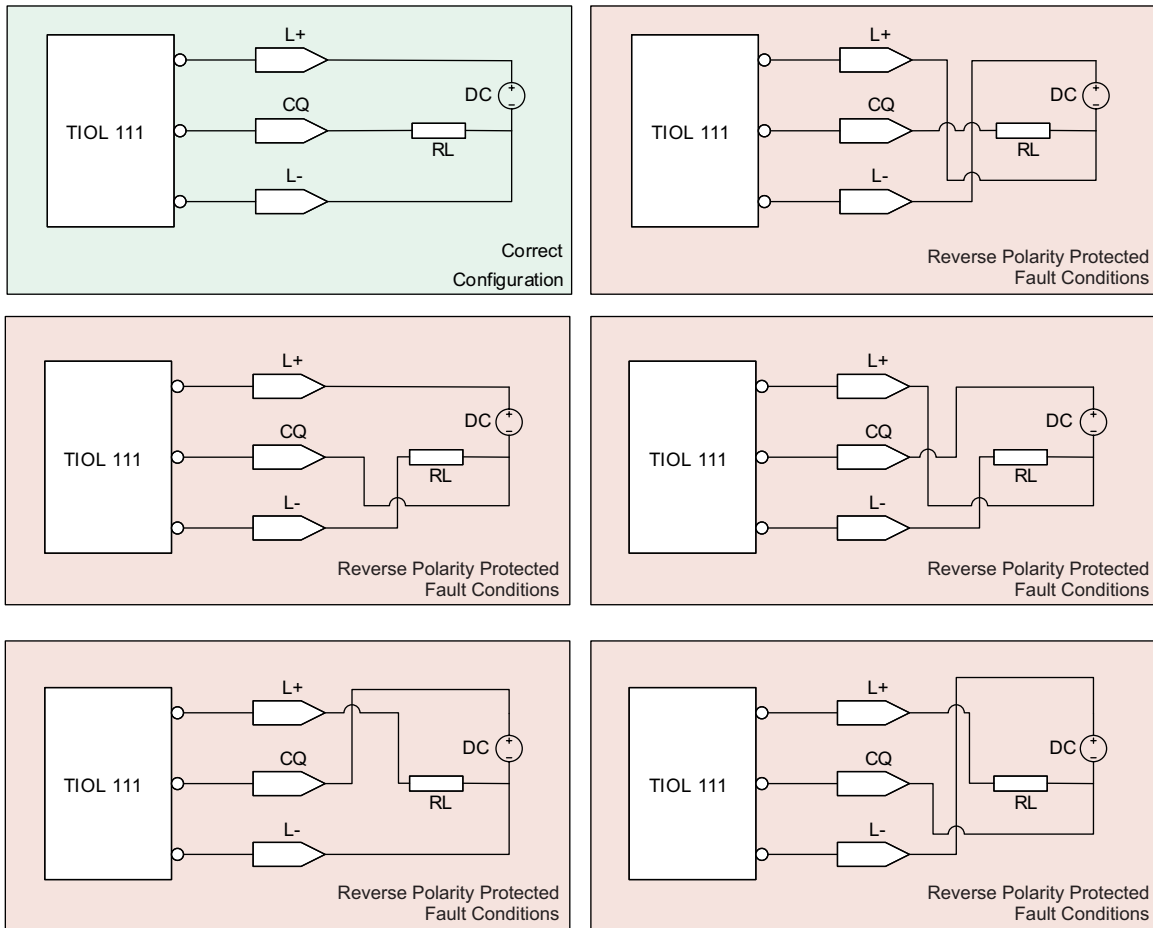

Copyright © 2017, Texas Instruments Incorporated

Figure 14. High-Side Driver Configuration

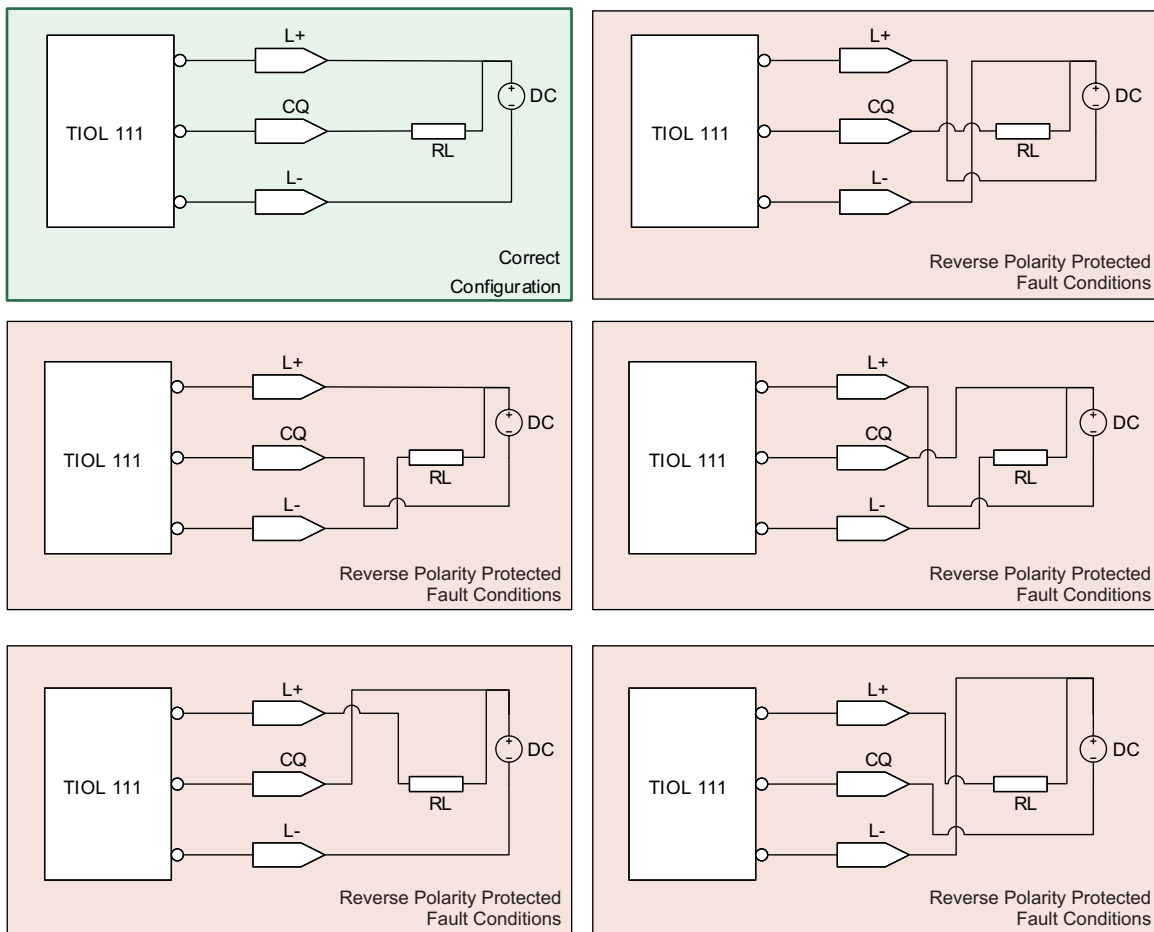

Copyright © 2017, Texas Instruments Incorporated

Figure 15. Low-Side Driver Configuration

8.3.9 Integrated Surge Protection and Transient Waveform Tolerance

The L+ and CQ pins of the device are capable of withstanding up to 1.2 kV of 1.2/50 – 8/20 μ s IEC 61000-4-5 surge with a source impedance of 500 Ω . The surge testing should be performed with a minimum 100 nF supply decoupling capacitor between L+ and L-, and 1 μ F between VCC_IN/OUT and L-.

External TVS diodes may be required for higher transient protection levels. The system designer should ensure that the maximum clamping voltage of the external diodes should be < 65 V at the desired current level. The device is capable of withstanding up to \pm 65-V transient pulses < 100 μ s.

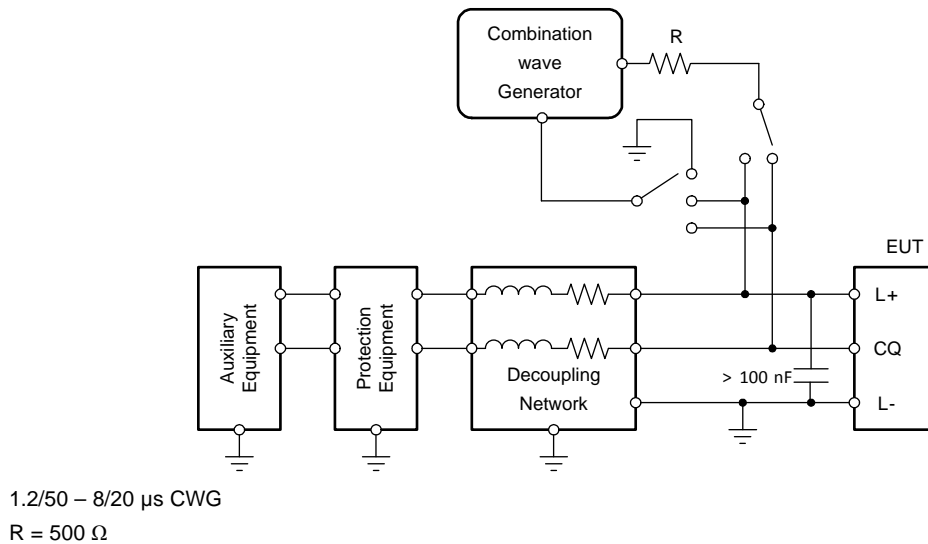

Figure 16. Surge Test Setup

8.3.10 Power Up Sequence (TIOL111)

VCC_IN and L+ domains can be powered up in any sequence. In the event of L+ is powered and VCC_IN is not, the CQ pin will remain in high impedance.

8.3.11 Undervoltage Lock-Out (UVLO)

The device enters UVLO if the L+ voltage falls below $V_{(UVLO)}$. (For the device without the integrated LDO, the device monitors VCC_IN in addition to L+. UVLO happens if either supply falls below the threshold.)

As soon as the supply falls below $V_{(UVLO)}$, NFAULT is pulled low, the LDO is turned off and the CQ output is disabled (Hi-Z). Receiver performance is not specified in this mode.

When the supply rises above $V_{(UVLO)}$, NFAULT returns to Hi-Z (given no other fault conditions present) and the LDO will be enabled immediately. The CQ output is turned on after $T_{(UVLO)}$ delay.

8.4 Device Functional Modes

These devices can operate in three different modes.

8.4.1 NPN Configuration (N-Switch SIO Mode)

Set TX pin high (or open) and use EN pin as control for realizing the function of an N-switch (low-side configuration) on CQ.

8.4.2 PNP Configuration (P-Switch SIO Mode)

Set TX pin low and use EN pin as control for realizing the function of a P-switch (high-side configuration) on CQ.

Device Functional Modes (continued)
8.4.3 Push-Pull, Communication Mode

Set EN pin high and toggle TX as control for realizing the function of a push-pull output on CQ. [Table 6](#), [Table 7](#) and [Table 8](#) summarize the pin configurations to accomplish the functional modes.

Table 6. NPN Mode

EN	TX	CQ
L / Open	H / Open	Hi-Z
H	H / Open	N-Switch

Table 7. PNP Mode

EN	TX	CQ
L / Open	L	Hi-Z
H	L	P-Switch

Table 8. Push-Pull, Communication Mode

EN	TX	CQ
L / Open	X	Hi-Z
H	H	N-Switch
H	L	P-Switch

9 Application and Implementation

NOTE

Information in the following applications sections is not part of the TI component specification, and TI does not warrant its accuracy or completeness. TI's customers are responsible for determining suitability of components for their purposes. Customers should validate and test their design implementation to confirm system functionality.

9.1 Application Information

When TIOL111 is connected to an IO-Link master through a three-wire interface (Figure 17), the master can initiate communication and exchange data with a remote node with the TIOL111 IO-Link transceiver acting as a complete physical layer for the communication.

9.2 Typical Application

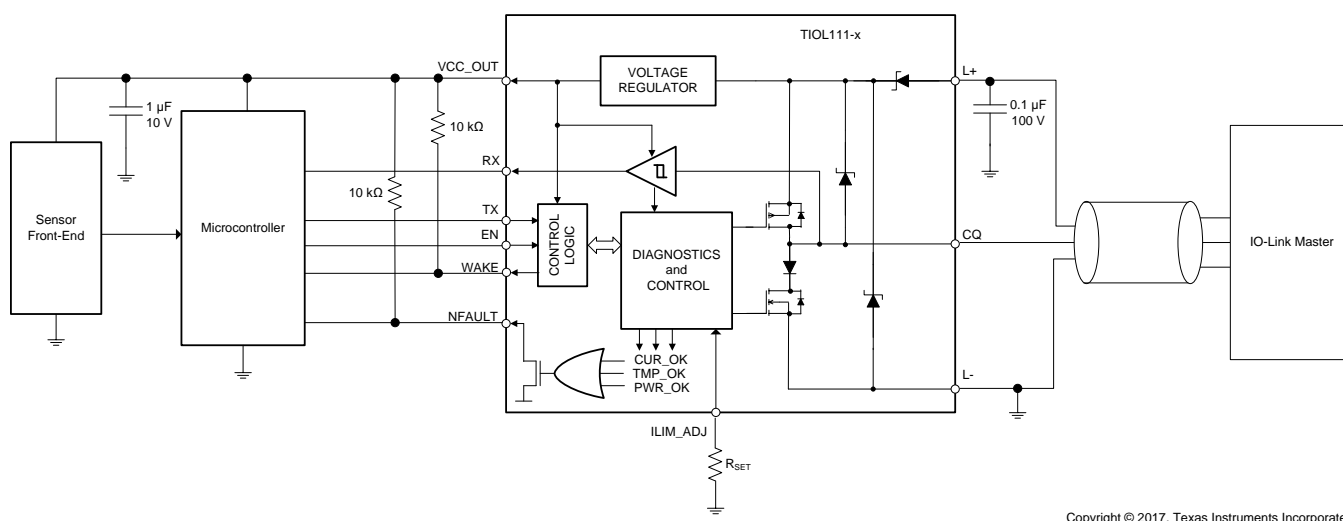

Copyright © 2017, Texas Instruments Incorporated

Figure 17. Typical Application Schematic

9.2.1 Design Requirements

TIOL111 and TIOL111-x IO-Link transceivers can be used in slave devices communicating with an IO-Link master, or as standard digital outputs to either sense or drive a wide range of sensors and loads. Table 9 shows recommended components for a typical system design.

Table 9. Design Parameters

PARAMETERS	VALUE
Input voltage range (L+)	24 V, 30 V (max)
Output current (CQ)	200 mA
Output voltage (VCC_OUT), Pick TIOL111-5	5 V
Maximum LDO output current (I _{VCC(OUT)})	5 mA
Pull-up resistors for NFAULT and WAKE	10 kΩ
L+ decoupling capacitor	0.1 μF / 100 V
LDO output capacitor	1 μF / 10 V
ILIM_ADJ resistor (R _{SET})	10 kΩ
Maximum Ambient Temperature, T _A	105 °C

9.2.2 Detailed Design Procedure

9.2.2.1 Maximum Junction Temperature Check

For a 200 mA current limit:

- The maximum driver output current limit, $I_{O(LIM)} = 250 \text{ mA}$ (allowed for current limit tolerance).
- The maximum voltage drop is given with $V_{DS(ON)} = 1.75 \text{ V}$.

This causes a power consumption of:

$$PD_{OP} = V_{DS(ON)} \times I_{O(LIM)} = 1.75 \text{ V} \times 250 \text{ mA} = 437.5 \text{ mW} \quad (1)$$

For a 5 mA LDO current output,

$$PD_{LDO} = (V_{L+} - V_{VCC_OUT}) \times I_{VCC_OUT} = (30 - 5) \text{ V} \times 5 \text{ mA} = 1.25 \text{ mW} \quad (2)$$

Total power dissipation,

$$PD = PD_{OP} + PD_{LDO} = 437.5 \text{ mW} + 125 \text{ mW} = 562.5 \text{ mW} \quad (3)$$

Multiply this value with the Junction-to-ambient thermal resistance of $\theta_{JA} = 68.1^\circ\text{C/W}$ (taken from the [Thermal Information](#) table) to receive the difference between junction temperature, T_J , and ambient temperature, T_A :

$$\Delta T = T_J - T_A = PD \times \theta_{JA} = 562.5 \text{ mW} \times 68.1^\circ\text{C/W} = 38.3^\circ\text{C} \quad (4)$$

Add this value to the maximum ambient temperature of $T_A = 105^\circ\text{C}$ to receive the final junction temperature:

$$T_{J-max} = T_{A-max} + \Delta T = 105^\circ\text{C} + 38.3^\circ\text{C} = 143.3^\circ\text{C} \quad (5)$$

As long as T_{J-max} is below the recommended maximum value of 150°C , no thermal shutdown will occur. However, thermal warning may occur as the junction temperature is greater than T_{WRN} .

Note that the modeling of the complete system may be necessary to predict junction temperature in smaller PCBs and/or enclosures without air flow.

9.2.2.2 Driving Capacitive Loads

These devices are capable of driving capacitive loads on the CQ output. Assuming a pure capacitive load without series/parallel resistance, the maximum capacitance that can be charged without triggering current fault can be calculated as:

$$C_{LOAD} = \frac{[I_{O(LIM)} \times t_{SC}]}{V_{(L+)}} \quad (6)$$

Higher capacitive loads can be driven if a series resistor is connected between the CQ output and the load. Capacitive loads can be connected to L- or L+.

9.2.2.3 Driving Inductive Loads

The TIOL111 family is capable of magnetizing and demagnetizing inductive loads up to 1.5H. These devices contain internal circuitry that enables fast demagnetization when configured as either P-switch or N-switch mode.

In P-switch configuration, the load inductor L is magnetized when the CQ output is driven high. When the PNP is turned off, there is a significant amount of negative inductive kick back at the CQ pin. This voltage is clamped internally at about -75 V.

Similarly in N-switch configuration, the load inductor L is magnetized when the CQ output is driven low. When the NPN is turned off, there is a significant amount of positive inductive kick back at the CQ pin. This voltage is clamped internally at about 75 V.

The equivalent protection circuits are shown in [Figure 18](#) and [Figure 19](#). The minimum value of the resistive load R can be calculated as:

$$R = \frac{V_{(L+)}}{I_{O(LIM)}} \quad (7)$$

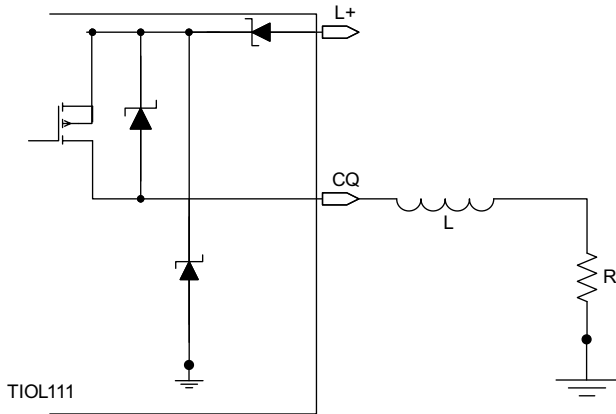

TIOL111

Copyright © 2016, Texas Instruments Incorporated

Figure 18. P-Switch Mode

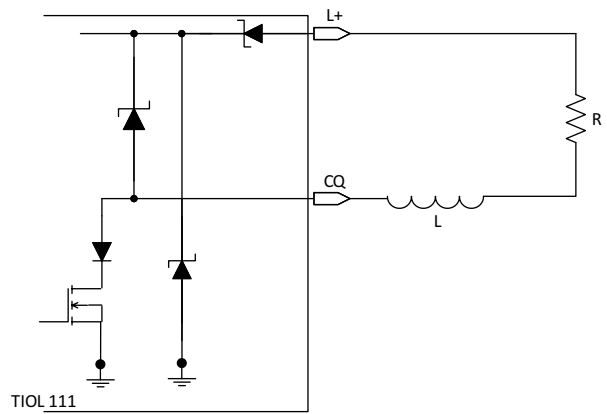

TIOL_111

Copyright © 2016, Texas Instruments Incorporated

Figure 19. N-Switch Mode

9.2.3 Application Curves

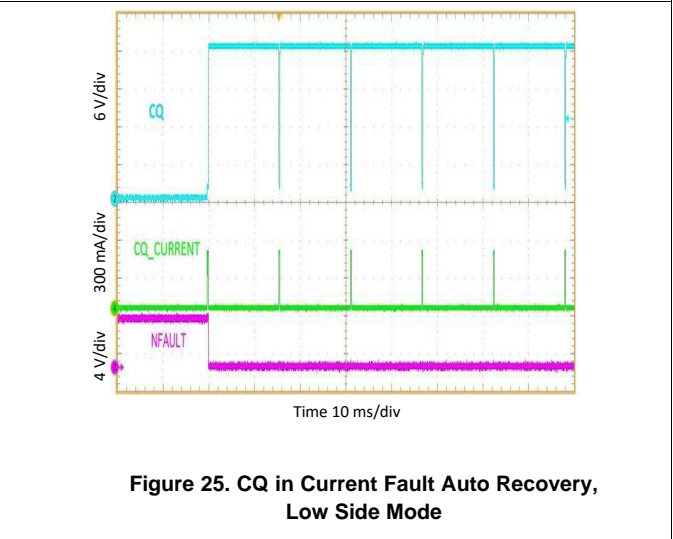
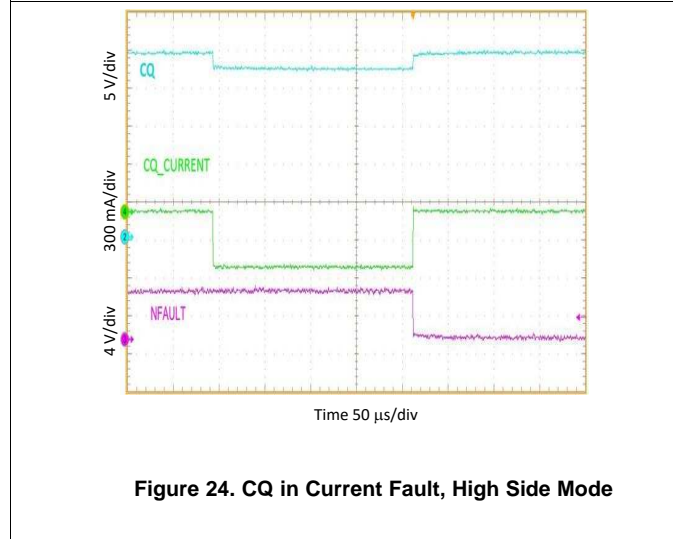
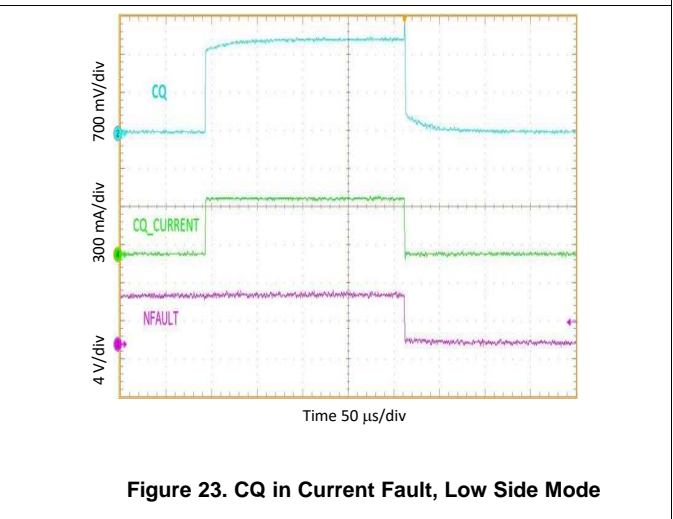
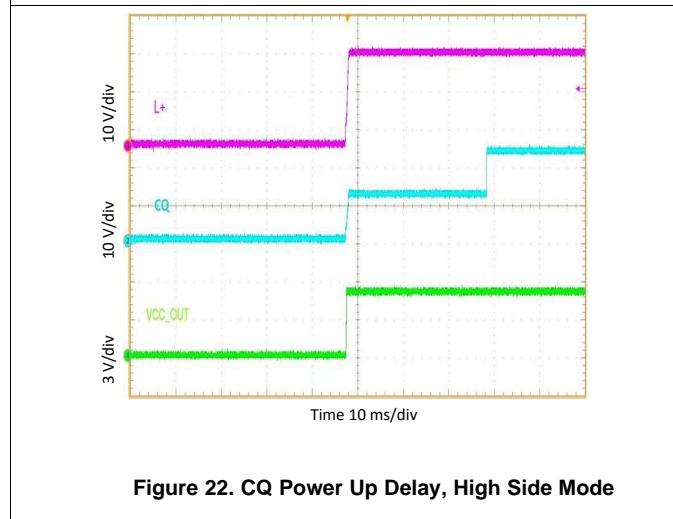
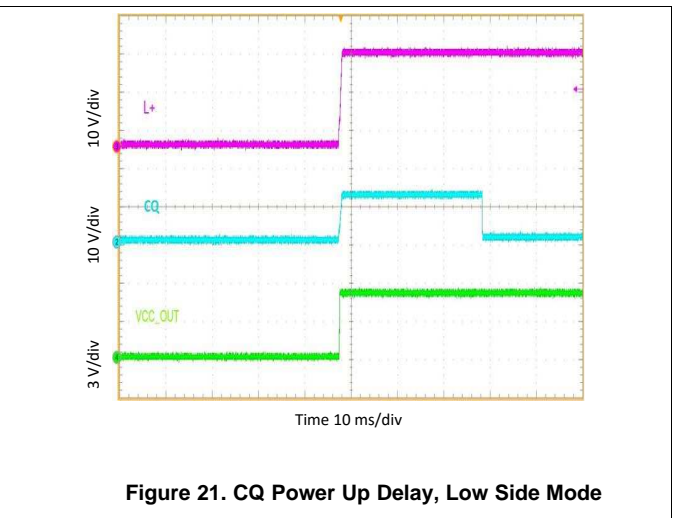
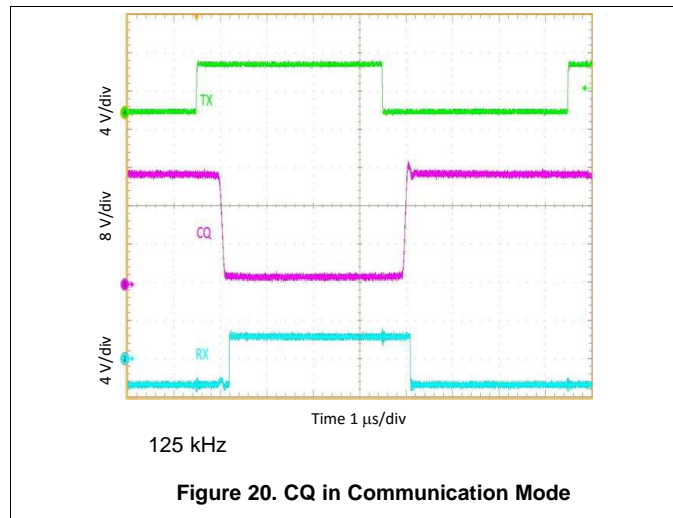

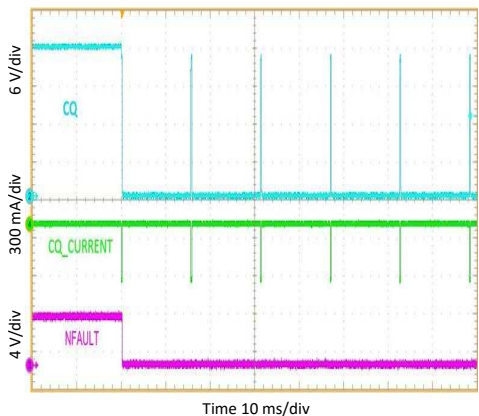

Figure 26. CQ in Current Fault Auto Recovery, High Side Mode

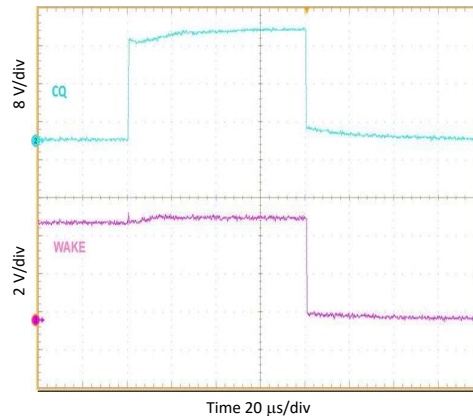

Figure 27. IO-Link WAKE, Low Side Mode

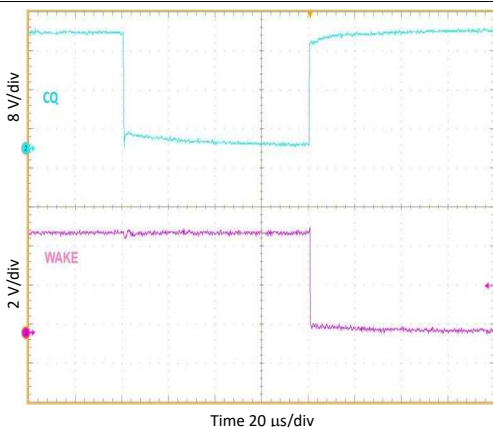

Figure 28. IO-Link WAKE, High Side Mode

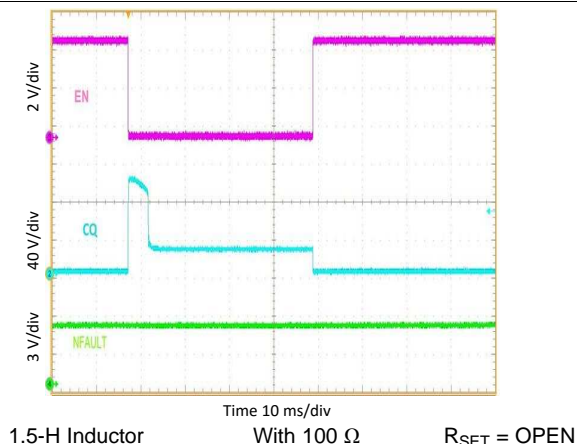

Figure 29. CQ Driving, Low Side Mode

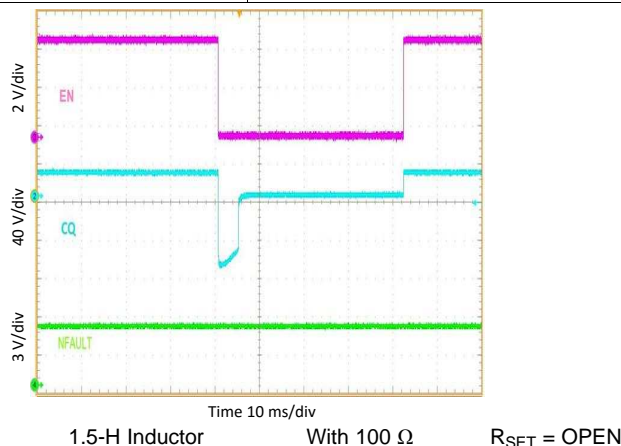

Figure 30. CQ Driving, High Side Mode

10 Power Supply Recommendations

The TIOL111 and TIOL111-x transceivers are designed to operate from a 24-V nominal supply at L+, which can vary by +12 V and -17 V from the nominal value to remain within the device's recommended supply voltage range of 7 V to 36 V. This supply should be buffered with at least a 100-nF/100-V capacitor.

11 Layout

11.1 Layout Guidelines

- Use of a 4-layer board is recommended for good heat conduction. Use layer 1 (top layer) for control signals, layer 2 as power ground layer for L-, layer 3 for the 24-V supply plane (L+), and layer 4 for the regulated output supply (VCC_IN/OUT).
- Connect the thermal pad to L- with maximum amount of thermal vias for best thermal performance.
- Use entire planes for L+, VCC_IN/OUT and L- to assure minimum inductance.
- The L+ terminal must be decoupled to ground with a low-ESR ceramic decoupling capacitor. The recommended minimum capacitor value is 100 nF. The capacitor must have a voltage rating of 50 V minimum (100 V depending on max sensor supply fault rating) and an X5R or X7R dielectric.
- The optimum placement of the capacitor is closest to the transceiver's L+ and L- terminals to reduce supply drops during large supply current loads. See [Figure 31](#) for a PCB layout example.
- Connect all open-drain control outputs via 10 kΩ pull-up resistors to the VCC_IN/OUT plane to provide a defined voltage potential to the system controller inputs when the outputs are high-impedance.
- Connect the R_{SET} resistor between ILIM_ADJ and L-.
- Decouple the regulated output voltage at VCC_IN/OUT to ground with a low-ESR, ≥ 1-μF, ceramic decoupling capacitor. The capacitor should have a voltage rating of 10 V minimum and an X5R or X7R dielectric.

11.2 Layout Example

- VIA to Layer 2: Power Ground Plane (L-)
- VIA to Layer 3: 24V Supply Plane (L+)
- VIA to Layer 4: Regulated Supply Plane (VCC_IN/OUT)

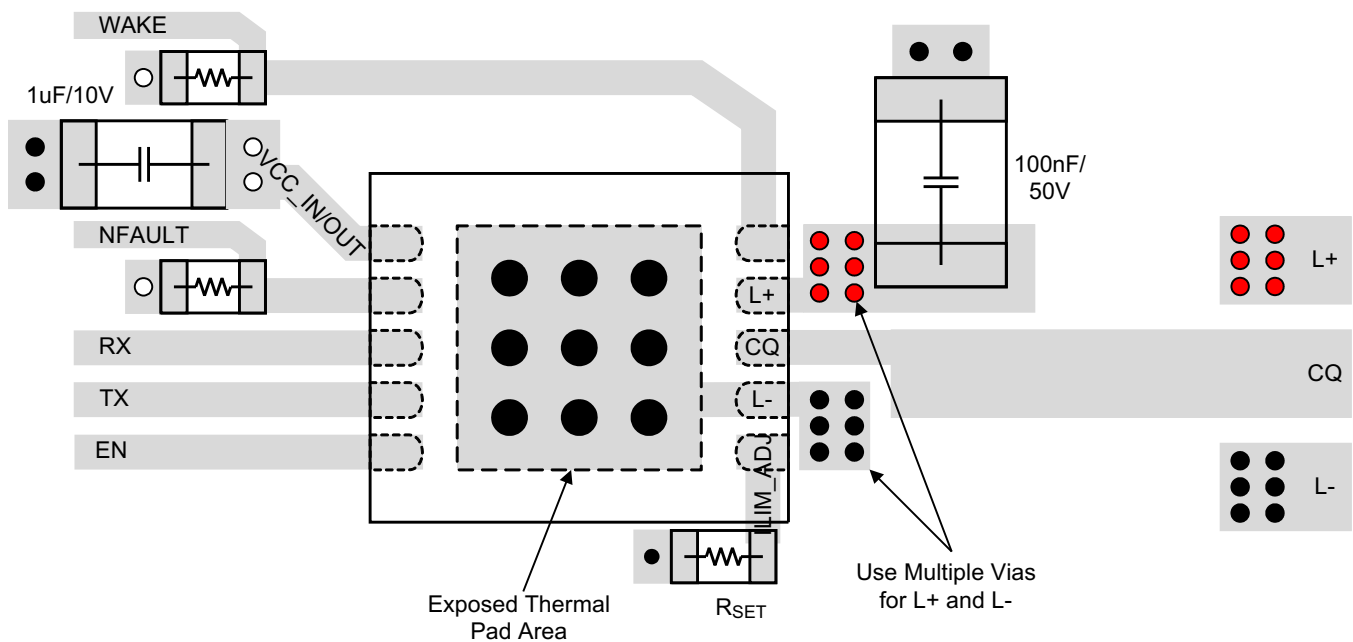

Figure 31. Layout Example

12 Device and Documentation Support

12.1 Receiving Notification of Documentation Updates

To receive notification of documentation updates, navigate to the device product folder on ti.com. In the upper right corner, click on *Alert me* to register and receive a weekly digest of any product information that has changed. For change details, review the revision history included in any revised document.

12.2 Community Resources

The following links connect to TI community resources. Linked contents are provided "AS IS" by the respective contributors. They do not constitute TI specifications and do not necessarily reflect TI's views; see TI's [Terms of Use](#).

TI E2E™ Online Community *TI's Engineer-to-Engineer (E2E) Community*. Created to foster collaboration among engineers. At e2e.ti.com, you can ask questions, share knowledge, explore ideas and help solve problems with fellow engineers.

Design Support *TI's Design Support* Quickly find helpful E2E forums along with design support tools and contact information for technical support.

12.3 Trademarks

E2E is a trademark of Texas Instruments.

12.4 Electrostatic Discharge Caution



This integrated circuit can be damaged by ESD. Texas Instruments recommends that all integrated circuits be handled with appropriate precautions. Failure to observe proper handling and installation procedures can cause damage.

ESD damage can range from subtle performance degradation to complete device failure. Precision integrated circuits may be more susceptible to damage because very small parametric changes could cause the device not to meet its published specifications.

12.5 Glossary

[SLYZ022](#) — *TI Glossary*.

This glossary lists and explains terms, acronyms, and definitions.

13 Mechanical, Packaging, and Orderable Information

The following pages include mechanical, packaging, and orderable information. This information is the most current data available for the designated devices. This data is subject to change without notice and revision of this document. For browser-based versions of this data sheet, refer to the left-hand navigation.

PACKAGING INFORMATION

Orderable Device	Status (1)	Package Type	Package Drawing	Pins	Package Qty	Eco Plan (2)	Lead/Ball Finish (6)	MSL Peak Temp (3)	Op Temp (°C)	Device Marking (4/5)	Samples
TIOL1113DMWR	PREVIEW	VSON	DMW	10	1500	TBD	Call TI	Call TI	-40 to 125		
TIOL1113DMWT	PREVIEW	VSON	DMW	10	250	TBD	Call TI	Call TI	-40 to 125		
TIOL1115DMWR	ACTIVE	VSON	DMW	10	1500	Green (RoHS & no Sb/Br)	CU NIPDAU	Level-2-260C-1 YEAR	-40 to 125	TL1115	Samples
TIOL1115DMWT	ACTIVE	VSON	DMW	10	250	Green (RoHS & no Sb/Br)	CU NIPDAU	Level-2-260C-1 YEAR	-40 to 125	TL1115	Samples
TIOL111DMWR	ACTIVE	VSON	DMW	10	1500	TBD	Call TI	Call TI	-40 to 125		Samples
TIOL111DMWT	ACTIVE	VSON	DMW	10	250	TBD	Call TI	Call TI	-40 to 125		Samples

(1) The marketing status values are defined as follows:

ACTIVE: Product device recommended for new designs.

LIFEBUY: TI has announced that the device will be discontinued, and a lifetime-buy period is in effect.

NRND: Not recommended for new designs. Device is in production to support existing customers, but TI does not recommend using this part in a new design.

PREVIEW: Device has been announced but is not in production. Samples may or may not be available.

OBSELETE: TI has discontinued the production of the device.

(2) **RoHS:** TI defines "RoHS" to mean semiconductor products that are compliant with the current EU RoHS requirements for all 10 RoHS substances, including the requirement that RoHS substance do not exceed 0.1% by weight in homogeneous materials. Where designed to be soldered at high temperatures, "RoHS" products are suitable for use in specified lead-free processes. TI may reference these types of products as "Pb-Free".

RoHS Exempt: TI defines "RoHS Exempt" to mean products that contain lead but are compliant with EU RoHS pursuant to a specific EU RoHS exemption.

Green: TI defines "Green" to mean the content of Chlorine (Cl) and Bromine (Br) based flame retardants meet JS709B low halogen requirements of <=1000ppm threshold. Antimony trioxide based flame retardants must also meet the <=1000ppm threshold requirement.

(3) MSL, Peak Temp. - The Moisture Sensitivity Level rating according to the JEDEC industry standard classifications, and peak solder temperature.

(4) There may be additional marking, which relates to the logo, the lot trace code information, or the environmental category on the device.

(5) Multiple Device Markings will be inside parentheses. Only one Device Marking contained in parentheses and separated by a "~" will appear on a device. If a line is indented then it is a continuation of the previous line and the two combined represent the entire Device Marking for that device.

(6) Lead/Ball Finish - Orderable Devices may have multiple material finish options. Finish options are separated by a vertical ruled line. Lead/Ball Finish values may wrap to two lines if the finish value exceeds the maximum column width.

Important Information and Disclaimer: The information provided on this page represents TI's knowledge and belief as of the date that it is provided. TI bases its knowledge and belief on information provided by third parties, and makes no representation or warranty as to the accuracy of such information. Efforts are underway to better integrate information from third parties. TI has taken and continues to take reasonable steps to provide representative and accurate information but may not have conducted destructive testing or chemical analysis on incoming materials and chemicals. TI and TI suppliers consider certain information to be proprietary, and thus CAS numbers and other limited information may not be available for release.

In no event shall TI's liability arising out of such information exceed the total purchase price of the TI part(s) at issue in this document sold by TI to Customer on an annual basis.

TAPE AND REEL INFORMATION



QUADRANT ASSIGNMENTS FOR PIN 1 ORIENTATION IN TAPE



*All dimensions are nominal

Device	Package Type	Package Drawing	Pins	SPQ	Reel Diameter (mm)	Reel Width W1 (mm)	A0 (mm)	B0 (mm)	K0 (mm)	P1 (mm)	W (mm)	Pin1 Quadrant
TIOL1115DMWR	VSON	DMW	10	1500	178.0	13.5	2.75	3.35	1.05	8.0	12.0	Q2
TIOL1115DMWT	VSON	DMW	10	250	178.0	13.5	2.75	3.35	1.05	8.0	12.0	Q2

TAPE AND REEL BOX DIMENSIONS

*All dimensions are nominal

Device	Package Type	Package Drawing	Pins	SPQ	Length (mm)	Width (mm)	Height (mm)
TIOL1115DMWR	VSON	DMW	10	1500	189.0	185.0	36.0
TIOL1115DMWT	VSON	DMW	10	250	189.0	185.0	36.0

IMPORTANT NOTICE

Texas Instruments Incorporated (TI) reserves the right to make corrections, enhancements, improvements and other changes to its semiconductor products and services per JESD46, latest issue, and to discontinue any product or service per JESD48, latest issue. Buyers should obtain the latest relevant information before placing orders and should verify that such information is current and complete.

TI's published terms of sale for semiconductor products (<http://www.ti.com/sc/docs/stdterms.htm>) apply to the sale of packaged integrated circuit products that TI has qualified and released to market. Additional terms may apply to the use or sale of other types of TI products and services.

Reproduction of significant portions of TI information in TI data sheets is permissible only if reproduction is without alteration and is accompanied by all associated warranties, conditions, limitations, and notices. TI is not responsible or liable for such reproduced documentation. Information of third parties may be subject to additional restrictions. Resale of TI products or services with statements different from or beyond the parameters stated by TI for that product or service voids all express and any implied warranties for the associated TI product or service and is an unfair and deceptive business practice. TI is not responsible or liable for any such statements.

Buyers and others who are developing systems that incorporate TI products (collectively, "Designers") understand and agree that Designers remain responsible for using their independent analysis, evaluation and judgment in designing their applications and that Designers have full and exclusive responsibility to assure the safety of Designers' applications and compliance of their applications (and of all TI products used in or for Designers' applications) with all applicable regulations, laws and other applicable requirements. Designer represents that, with respect to their applications, Designer has all the necessary expertise to create and implement safeguards that (1) anticipate dangerous consequences of failures, (2) monitor failures and their consequences, and (3) lessen the likelihood of failures that might cause harm and take appropriate actions. Designer agrees that prior to using or distributing any applications that include TI products, Designer will thoroughly test such applications and the functionality of such TI products as used in such applications.

TI's provision of technical, application or other design advice, quality characterization, reliability data or other services or information, including, but not limited to, reference designs and materials relating to evaluation modules, (collectively, "TI Resources") are intended to assist designers who are developing applications that incorporate TI products; by downloading, accessing or using TI Resources in any way, Designer (individually or, if Designer is acting on behalf of a company, Designer's company) agrees to use any particular TI Resource solely for this purpose and subject to the terms of this Notice.

TI's provision of TI Resources does not expand or otherwise alter TI's applicable published warranties or warranty disclaimers for TI products, and no additional obligations or liabilities arise from TI providing such TI Resources. TI reserves the right to make corrections, enhancements, improvements and other changes to its TI Resources. TI has not conducted any testing other than that specifically described in the published documentation for a particular TI Resource.

Designer is authorized to use, copy and modify any individual TI Resource only in connection with the development of applications that include the TI product(s) identified in such TI Resource. NO OTHER LICENSE, EXPRESS OR IMPLIED, BY ESTOPPEL OR OTHERWISE TO ANY OTHER TI INTELLECTUAL PROPERTY RIGHT, AND NO LICENSE TO ANY TECHNOLOGY OR INTELLECTUAL PROPERTY RIGHT OF TI OR ANY THIRD PARTY IS GRANTED HEREIN, including but not limited to any patent right, copyright, mask work right, or other intellectual property right relating to any combination, machine, or process in which TI products or services are used. Information regarding or referencing third-party products or services does not constitute a license to use such products or services, or a warranty or endorsement thereof. Use of TI Resources may require a license from a third party under the patents or other intellectual property of the third party, or a license from TI under the patents or other intellectual property of TI.

TI RESOURCES ARE PROVIDED "AS IS" AND WITH ALL FAULTS. TI DISCLAIMS ALL OTHER WARRANTIES OR REPRESENTATIONS, EXPRESS OR IMPLIED, REGARDING RESOURCES OR USE THEREOF, INCLUDING BUT NOT LIMITED TO ACCURACY OR COMPLETENESS, TITLE, ANY EPIDEMIC FAILURE WARRANTY AND ANY IMPLIED WARRANTIES OF MERCHANTABILITY, FITNESS FOR A PARTICULAR PURPOSE, AND NON-INFRINGEMENT OF ANY THIRD PARTY INTELLECTUAL PROPERTY RIGHTS. TI SHALL NOT BE LIABLE FOR AND SHALL NOT DEFEND OR INDEMNIFY DESIGNER AGAINST ANY CLAIM, INCLUDING BUT NOT LIMITED TO ANY INFRINGEMENT CLAIM THAT RELATES TO OR IS BASED ON ANY COMBINATION OF PRODUCTS EVEN IF DESCRIBED IN TI RESOURCES OR OTHERWISE. IN NO EVENT SHALL TI BE LIABLE FOR ANY ACTUAL, DIRECT, SPECIAL, COLLATERAL, INDIRECT, PUNITIVE, INCIDENTAL, CONSEQUENTIAL OR EXEMPLARY DAMAGES IN CONNECTION WITH OR ARISING OUT OF TI RESOURCES OR USE THEREOF, AND REGARDLESS OF WHETHER TI HAS BEEN ADVISED OF THE POSSIBILITY OF SUCH DAMAGES.

Unless TI has explicitly designated an individual product as meeting the requirements of a particular industry standard (e.g., ISO/TS 16949 and ISO 26262), TI is not responsible for any failure to meet such industry standard requirements.

Where TI specifically promotes products as facilitating functional safety or as compliant with industry functional safety standards, such products are intended to help enable customers to design and create their own applications that meet applicable functional safety standards and requirements. Using products in an application does not by itself establish any safety features in the application. Designers must ensure compliance with safety-related requirements and standards applicable to their applications. Designer may not use any TI products in life-critical medical equipment unless authorized officers of the parties have executed a special contract specifically governing such use. Life-critical medical equipment is medical equipment where failure of such equipment would cause serious bodily injury or death (e.g., life support, pacemakers, defibrillators, heart pumps, neurostimulators, and implantables). Such equipment includes, without limitation, all medical devices identified by the U.S. Food and Drug Administration as Class III devices and equivalent classifications outside the U.S.

TI may expressly designate certain products as completing a particular qualification (e.g., Q100, Military Grade, or Enhanced Product). Designers agree that it has the necessary expertise to select the product with the appropriate qualification designation for their applications and that proper product selection is at Designers' own risk. Designers are solely responsible for compliance with all legal and regulatory requirements in connection with such selection.

Designer will fully indemnify TI and its representatives against any damages, costs, losses, and/or liabilities arising out of Designer's non-compliance with the terms and provisions of this Notice.