

1 2 3 4 5 6 7 8 9 10

A
B
C
D
E
F
G

目錄 MAPX	設變內容 MODIFICATION	日期 DATE

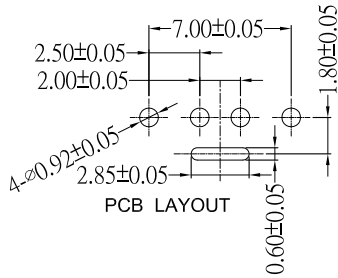
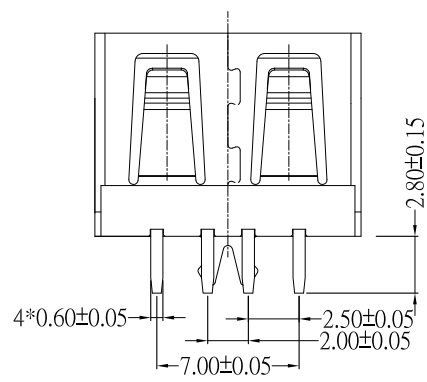
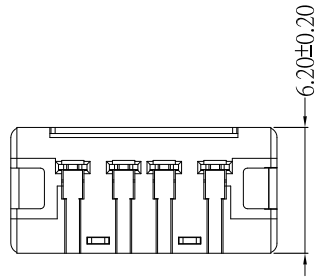
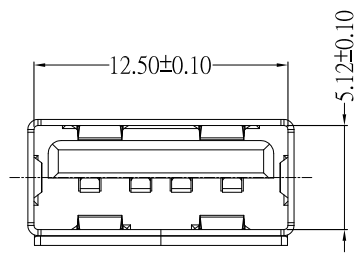
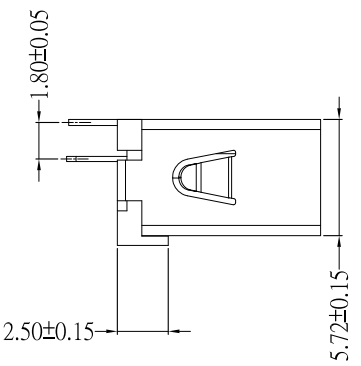
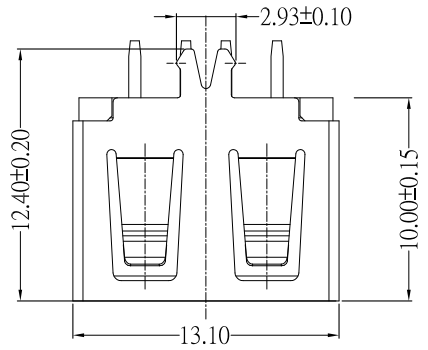

NOTES:

- 1. HOUSING: SEE NOTES,
- TERMINAL: SEE NOTES.
- SHELL: SEE NOTES.

SPECIFICATION:

- 1. ELECTRICAL CHARACTERISTIC:
 - CONTACT RESISTANCE: 30MΩ MAX
 - DIELECTRIC WITHSTANDING VOLTAGE: 500V AC FOR 1MIN
 - INSULATION RESISTANCE: 1000MΩ MIN
- 2. MECHANICAL CHARACTERISTIC:
 - INSERTION FORCE: 35N(3.57KGF) MAX
 - EXTRACTION FORCE: 10~35N(1.02~3.57KGF)MIN
 - DURABILITY: 1500 CYCLES EXTRACTION FORCE:10~35N
- 3. ENVIRONMENTAL:
 - OPERATING TEMPERATURE: -55℃+85℃
- 4. Contact finish:
 - 01:Selective Gold Flash
 - 02:Selective Gold 3U"
 - 03:Selective Gold 5U"
 - 04:Selective Gold 15U"
 - 05:Selective Gold 30U"

产品图 PRODUCT CHART DWG		深圳市精拓金电子有限公司					
公差一览表 TOLERANCE UNLESS OTHERWISE		单位 UNITS	MM	制图 DRAWING	Z-Y-B	产品料号 PRODUCT PART NO.	910-562A1015Y10200
X.	±0.25	X'	±5'	比例 SCALE	审核 CHKD	产品名称 PRODUCT NO.	AF10.0C款180度侧鱼叉脚无边铜壳 一型PBT防火白胶
.X	±0.20	.X'	±2'				
.XX	±0.15	.XX'	±1'	日期 DATE	核准 APPD	角法 VIEW	版本 VER
.XXX	±0.10	.XXX'	±0.5'				

1 2 3 4 5 6 7 8 9 10