



# STW9NK95Z

N-channel 950 V - 1.15  $\Omega$  - 7 A - TO-247  
Zener-protected SuperMESH™ Power MOSFET

## Features

Type	V <sub>DSS</sub>	R <sub>DS(on) Max</sub>	I <sub>D</sub>	P <sub>w</sub>
STW9NK95Z	950 V	< 1.38 $\Omega$	7 A	160 W

- Extremely high dv/dt capability
- 100% avalanche tested
- Gate charge minimized

## Application

- Switching applications

## Description

The SuperMESH™ series is obtained through an extreme optimization of ST's well established strip-based PowerMESH™ layout. In addition to pushing on-resistance significantly down, special care is taken to ensure a very good dv/dt capability for the most demanding applications.

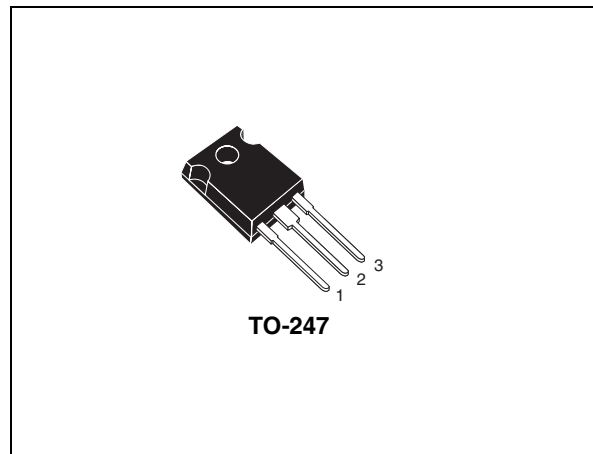

Figure 1. Internal schematic diagram

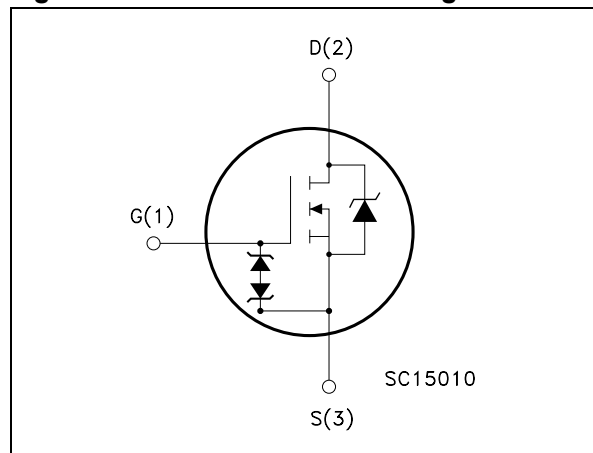

Table 1. Device summary

Order code	Marking	Package	Packaging
STW9NK95Z	9NK95Z	TO-247	Tube

# Contents

<b>1</b>	<b>Electrical ratings</b> .....	<b>3</b>
<b>2</b>	<b>Electrical characteristics</b> .....	<b>4</b>
	2.1 Electrical characteristics (curves) .....	6
<b>3</b>	<b>Test circuits</b> .....	<b>8</b>
<b>4</b>	<b>Package mechanical data</b> .....	<b>9</b>
<b>5</b>	<b>Revision history</b> .....	<b>11</b>

# 1 Electrical ratings

**Table 2. Absolute maximum ratings**

Symbol	Parameter	Value	Unit
$V_{DS}$	Drain-source voltage ( $V_{GS} = 0$ )	950	V
$V_{GS}$	Gate-source voltage	$\pm 30$	V
$I_D$	Drain current (continuous) at $T_C = 25\text{ }^\circ\text{C}$	7	A
$I_D$	Drain current (continuous) at $T_C = 100\text{ }^\circ\text{C}$	4.41	A
$I_{DM}^{(1)}$	Drain current (pulsed)	28	A
$P_{TOT}$	Total dissipation at $T_C = 25\text{ }^\circ\text{C}$	160	W
	Derating Factor	1.28	W/ $^\circ\text{C}$
$V_{esd}(G-S)$	G-S ESD (HBM $C=100\text{ pF}$ , $R=1.5\text{ k}\Omega$ )	4000	V
$dv/dt^{(2)}$	Peak diode recovery voltage slope	4.5	V/ns
$T_J$ $T_{stg}$	Operating junction temperature Storage temperature	-55 to 150	$^\circ\text{C}$

1. Pulse width limited by safe operating area

2.  $I_{SD} \leq 7\text{ A}$ ,  $di/dt \leq 100\text{ A}/\mu\text{s}$ ,  $V_{DD} \leq 80\% V_{(BR)DSS}$

**Table 3. Thermal data**

Symbol	Parameter	Value	Unit
$R_{thj-case}$	Thermal resistance junction-case max	0.78	$^\circ\text{C}/\text{W}$
$R_{thj-a}$	Thermal resistance junction-ambient max	50	$^\circ\text{C}/\text{W}$
$T_l$	Maximum lead temperature for soldering purpose	300	$^\circ\text{C}$

**Table 4. Avalanche characteristics**

Symbol	Parameter	Value	Unit
$I_{AS}$	Avalanche current, repetitive or not-repetitive (pulse width limited by $T_J$ Max)	7	A
$E_{AS}$	Single pulse avalanche energy (starting $T_J=25\text{ }^\circ\text{C}$ , $I_D=I_{AS}$ , $V_{DD}=50\text{ V}$ ) (see Figure 17) and (see Figure 18)	300	mJ

## 2 Electrical characteristics

( $T_{CASE}=25^{\circ}C$  unless otherwise specified)

**Table 5. On/off states**

Symbol	Parameter	Test conditions	Min.	Typ.	Max.	Unit
$V_{(BR)DSS}$	Drain-source breakdown voltage	$I_D = 1 \text{ mA}, V_{GS} = 0$	950			V
$I_{DSS}$	Zero gate voltage drain current ( $V_{GS} = 0$ )	$V_{DS} = \text{max rating},$ $V_{DS} = \text{max rating} @ 125^{\circ}C$			1 50	$\mu A$ $\mu A$
$I_{GSS}$	Gate body leakage current ( $V_{DS} = 0$ )	$V_{GS} = \pm 20 \text{ V}, V_{DS} = 0$			$\pm 10$	$\mu A$
$V_{GS(th)}$	Gate threshold voltage	$V_{DS} = V_{GS}, I_D = 100 \mu A$	3	3.75	4.5	V
$R_{DS(on)}$	Static drain-source on resistance	$V_{GS} = 10 \text{ V}, I_D = 3.6 \text{ A}$		1.15	1.38	$\Omega$

**Table 6. Dynamic**

Symbol	Parameter	Test conditions	Min.	Typ.	Max.	Unit
$g_{fs}^{(1)}$	Forward transconductance	$V_{DS} = 15 \text{ V}, I_D = 3.6 \text{ A}$		5.7		S
$C_{iss}$	Input capacitance	$V_{DS} = 25 \text{ V}, f = 1 \text{ MHz},$ $V_{GS} = 0$		2256		pF
$C_{oss}$	Output capacitance			189		pF
$C_{rss}$	Reverse transfer capacitance			30		pF
$C_{oss \text{ eq}}^{(2)}$	Equivalent output capacitance	$V_{GS} = 0, V_{DS} = 0 \text{ to } 760 \text{ V}$		37		pF
$R_G$	Intrinsic gate resistance	$f = 1 \text{ MHz}, \text{ open drain}$		1.6		$\Omega$
$Q_g$	Total gate charge	$V_{DD} = 760 \text{ V}, I_D = 7.2 \text{ A}$ $V_{GS} = 10 \text{ V}$ <i>(see Figure 15)</i>		56		nC
$Q_{gs}$	Gate-source charge			10		nC
$Q_{gd}$	Gate-drain charge			30		nC

1. Pulsed: pulse duration=300 $\mu s$ , duty cycle 1.5%

2.  $C_{oss \text{ eq}}$  is defined as a constant equivalent capacitance giving the same charging time as  $C_{oss}$  when  $V_{DS}$  increases from 0 to 80%  $V_{DSS}$

**Table 7. Switching times**

Symbol	Parameter	Test conditions	Min.	Typ.	Max.	Unit
$t_{d(on)}$ $t_r$	Turn-on delay time Rise Time	$V_{DD}= 475\text{ V}$ , $I_D= 3.6\text{ A}$ , $R_G= 4.7\ \Omega$ , $V_{GS}= 10\text{ V}$ <i>(see Figure 14)</i> <i>(see Figure 19)</i>		22 15		ns ns
$t_{d(off)}$ $t_f$	Turn-off delay time Fall time	$V_{DD}= 475\text{ V}$ , $I_D= 3.6\text{ A}$ , $R_G= 4.7\ \Omega$ , $V_{GS}= 10\text{ V}$ <i>(see Figure 14)</i> <i>(see Figure 19)</i>		51 22		ns ns

**Table 8. Gate-source Zener diode**

Symbol	Parameter	Test conditions	Min.	Typ.	Max.	Unit
$BV_{GSO}^{(1)}$	Gate-source breakdown voltage	$I_{GS}=\pm 1\text{ mA}$ (open drain)	30			V

1. The built-in back-to-back Zener diodes have specifically been designed to enhance not only the device's ESD capability, but also to make them safely absorb possible voltage transients that may occasionally be applied from gate to source. In this respect the Zener voltage is appropriate to achieve an efficient and cost-effective intervention to protect the device's integrity. These integrated Zener diodes thus avoid the usage of external components.

**Table 9. Source drain diode**

Symbol	Parameter	Test conditions	Min	Typ.	Max	Unit
$I_{SD}$	Source-drain current				7	A
$I_{SDM}^{(1)}$	Source-drain current (pulsed)				28	A
$V_{SD}^{(2)}$	Forward on voltage	$I_{SD}= 7.2\text{ A}$ , $V_{GS}=0$			1.6	V
$t_{rr}$ $Q_{rr}$ $I_{RRM}$	Reverse recovery time Reverse recovery charge Reverse recovery current	$I_{SD}= 7.2\text{ A}$ , $di/dt = 100\text{ A}/\mu\text{s}$ , $V_{DD}= 60\text{ V}$ , $T_j = 25^\circ\text{C}$ <i>(see Figure 16)</i>		660 5.9 18		ns $\mu\text{C}$ A
$t_{rr}$ $Q_{rr}$ $I_{RRM}$	Reverse recovery time Reverse recovery charge Reverse recovery current	$I_{SD}= 7.2\text{ A}$ , $di/dt = 100\text{ A}/\mu\text{s}$ , $V_{DD}= 60\text{ V}$ , $T_j = 150^\circ\text{C}$ <i>(see Figure 16)</i>		800 7.4 18.6		ns $\mu\text{C}$ A

1. Pulse width limited by safe operating area  
2. Pulsed: pulse duration=300 $\mu\text{s}$ , duty cycle 1.5%

## 2.1 Electrical characteristics (curves)

Figure 2. Safe operating area

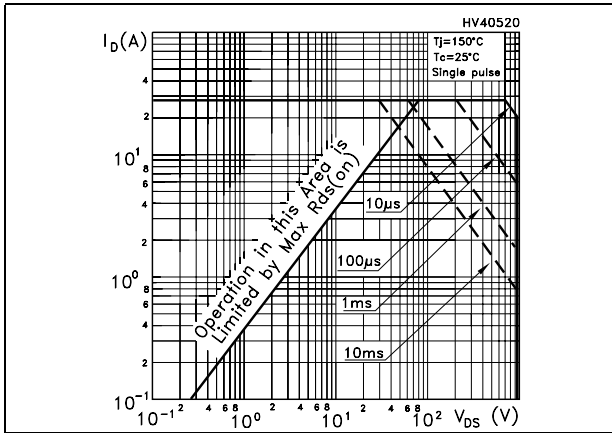

Figure 3. Thermal impedance

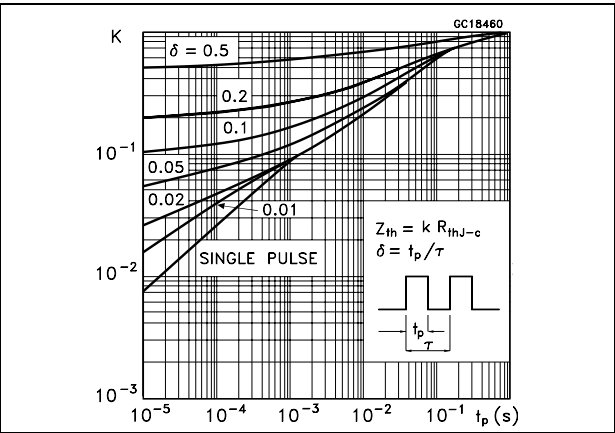

Figure 4. Output characteristics

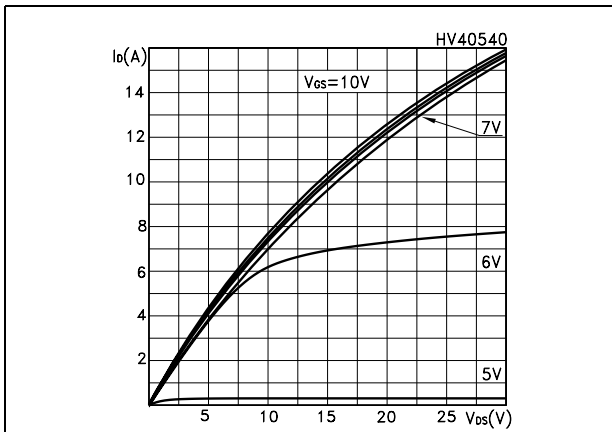

Figure 5. Transfer characteristics

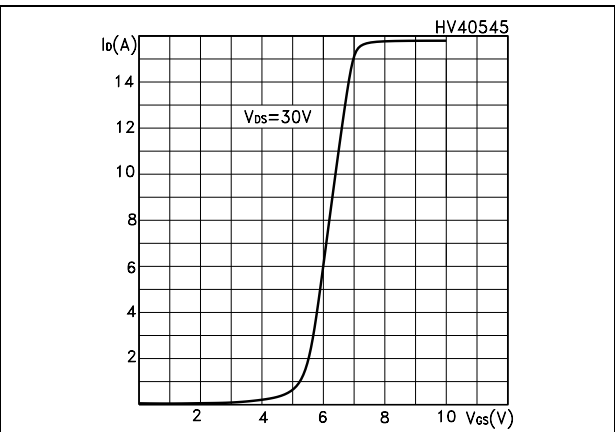

Figure 6. Normalized  $B_{V_{DS}}$  vs temperature

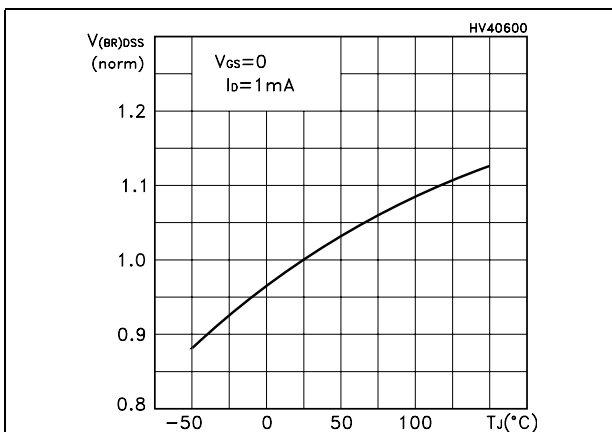

Figure 7. Static drain-source on resistance

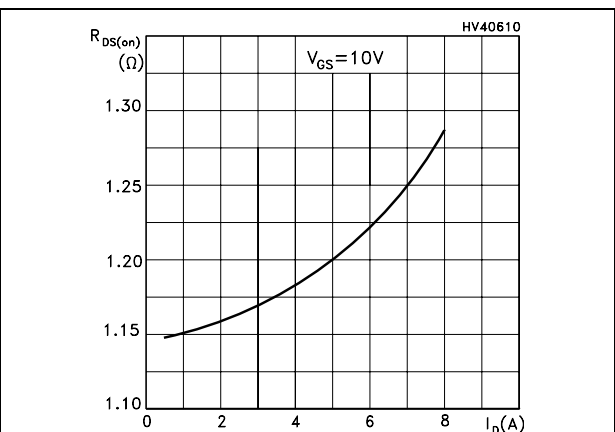

Figure 8. Gate charge vs gate-source voltage Figure 9. Capacitance variations

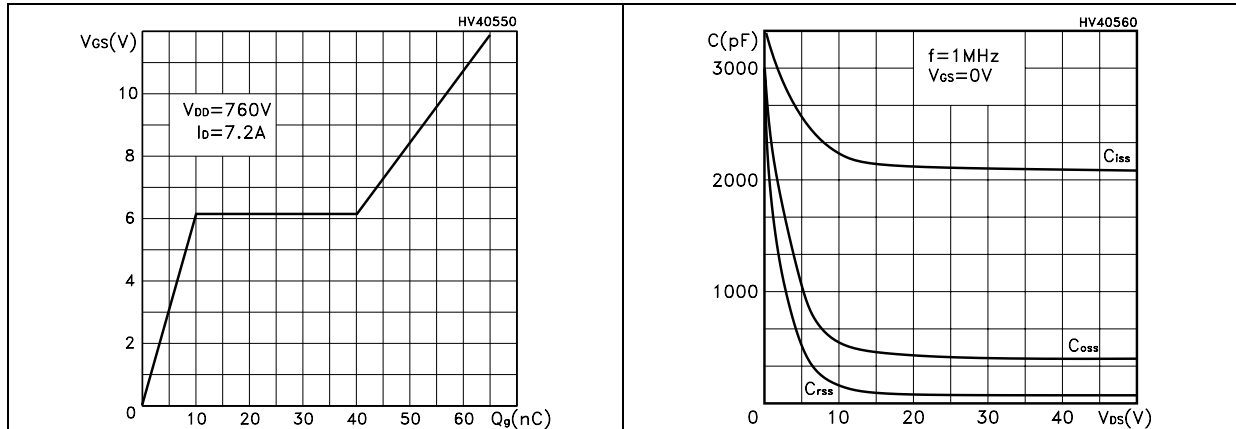

Figure 10. Normalized gate threshold voltage vs temperature Figure 11. Normalized on resistance vs temperature

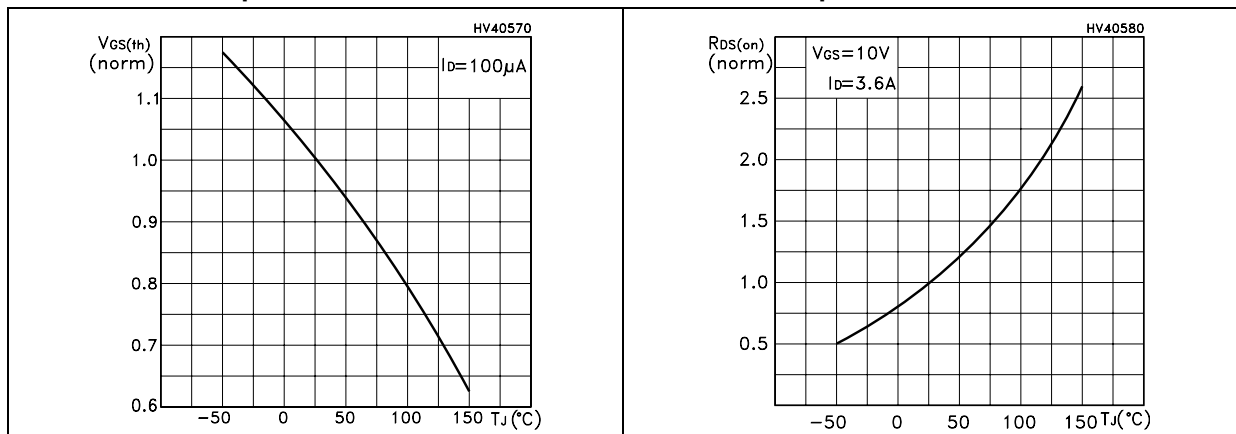
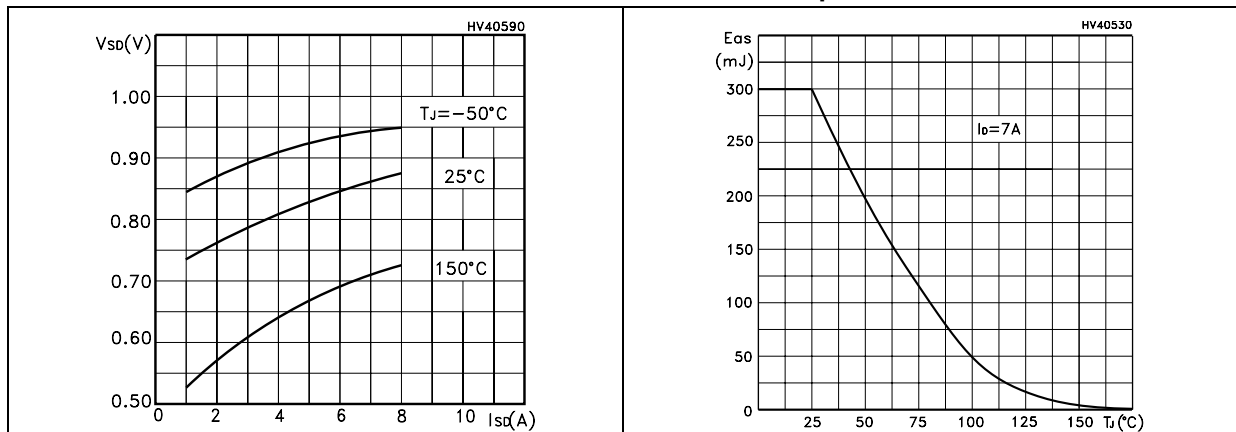

Figure 12. Source-drain diode forward characteristics Figure 13. Maximum avalanche energy vs temperature



### 3 Test circuits

Figure 14. Switching times test circuit for resistive load

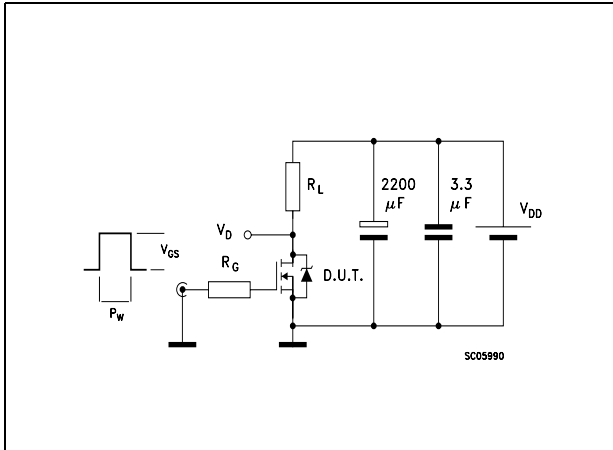

Figure 15. Gate charge test circuit

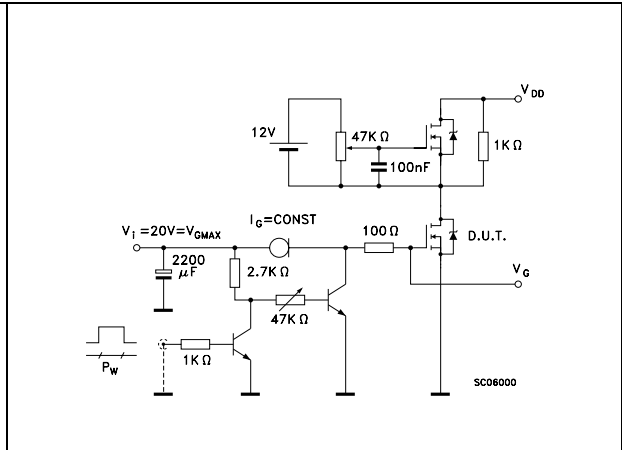

Figure 16. Test circuit for inductive load switching and diode recovery times

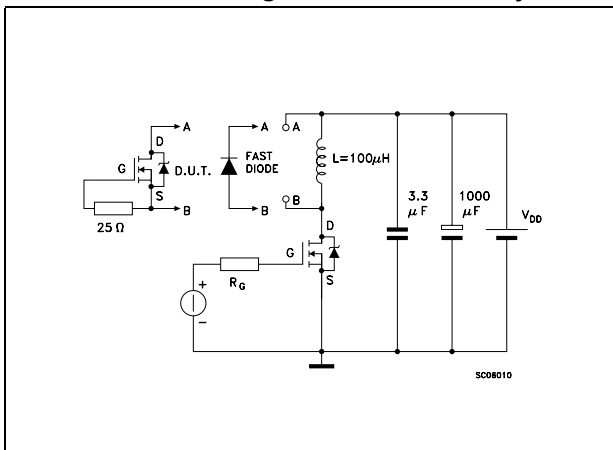

Figure 17. Unclamped Inductive load test circuit

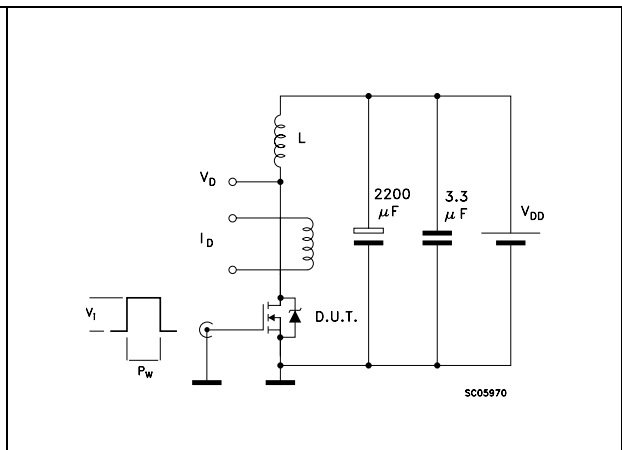

Figure 18. Unclamped inductive waveform

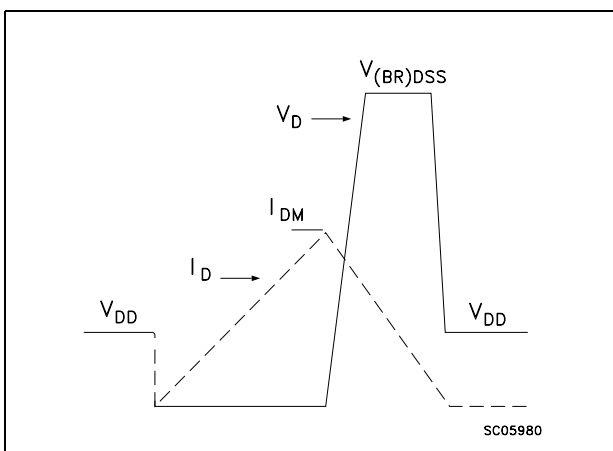
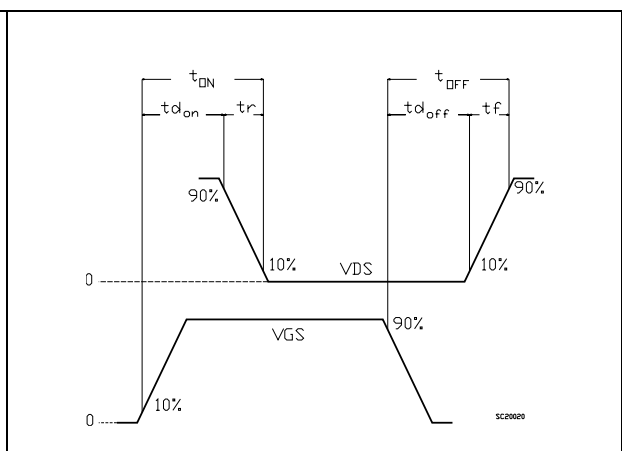

Figure 19. Switching time waveform





## 4 Package mechanical data

In order to meet environmental requirements, ST offers these devices in ECOPACK® packages. These packages have a Lead-free second level interconnect. The category of second level interconnect is marked on the package and on the inner box label, in compliance with JEDEC Standard JESD97. The maximum ratings related to soldering conditions are also marked on the inner box label. ECOPACK is an ST trademark. ECOPACK specifications are available at: [www.st.com](http://www.st.com)

**TO-247 Mechanical data**

Dim.	mm.		
	Min.	Typ	Max.
A	4.85		5.15
A1	2.20		2.60
b	1.0		1.40
b1	2.0		2.40
b2	3.0		3.40
c	0.40		0.80
D	19.85		20.15
E	15.45		15.75
e		5.45	
L	14.20		14.80
L1	3.70		4.30
L2		18.50	
øP	3.55		3.65
øR	4.50		5.50
S		5.50	

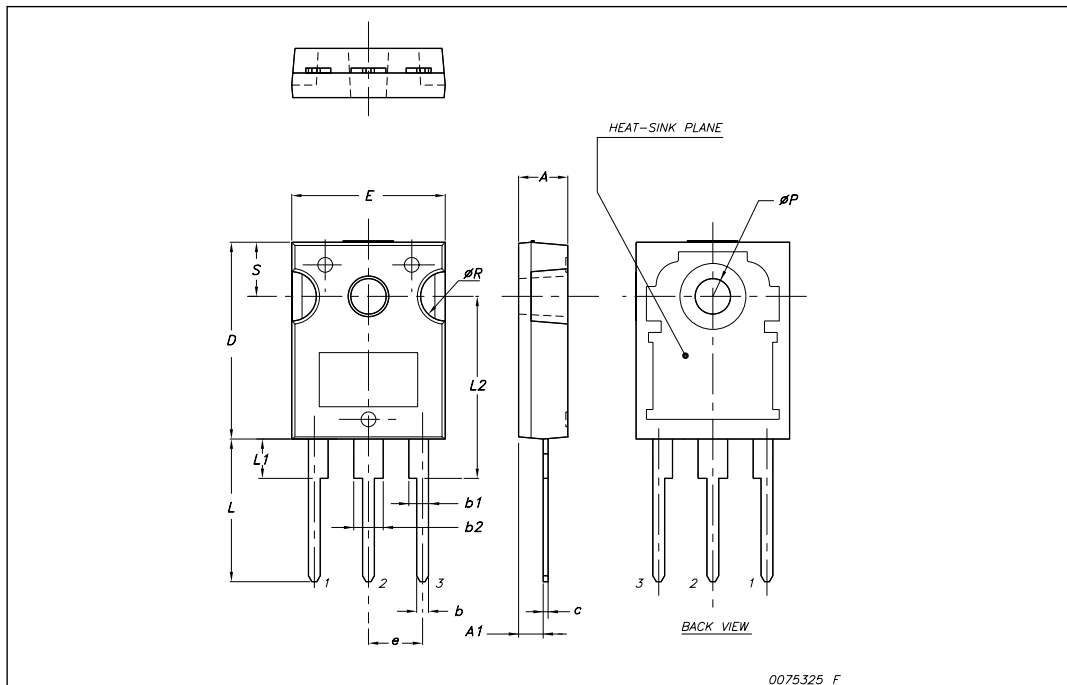

## 5 Revision history

Table 10. Document revision history

Date	Revision	Changes
11-Oct-2006	1	Initial release
03-Jul-2008	2	Updated <a href="#">Figure 6</a> , <a href="#">Figure 7</a> , <a href="#">Figure 9</a>

**Please Read Carefully:**

Information in this document is provided solely in connection with ST products. STMicroelectronics NV and its subsidiaries ("ST") reserve the right to make changes, corrections, modifications or improvements, to this document, and the products and services described herein at any time, without notice.

All ST products are sold pursuant to ST's terms and conditions of sale.

Purchasers are solely responsible for the choice, selection and use of the ST products and services described herein, and ST assumes no liability whatsoever relating to the choice, selection or use of the ST products and services described herein.

No license, express or implied, by estoppel or otherwise, to any intellectual property rights is granted under this document. If any part of this document refers to any third party products or services it shall not be deemed a license grant by ST for the use of such third party products or services, or any intellectual property contained therein or considered as a warranty covering the use in any manner whatsoever of such third party products or services or any intellectual property contained therein.

**UNLESS OTHERWISE SET FORTH IN ST'S TERMS AND CONDITIONS OF SALE ST DISCLAIMS ANY EXPRESS OR IMPLIED WARRANTY WITH RESPECT TO THE USE AND/OR SALE OF ST PRODUCTS INCLUDING WITHOUT LIMITATION IMPLIED WARRANTIES OF MERCHANTABILITY, FITNESS FOR A PARTICULAR PURPOSE (AND THEIR EQUIVALENTS UNDER THE LAWS OF ANY JURISDICTION), OR INFRINGEMENT OF ANY PATENT, COPYRIGHT OR OTHER INTELLECTUAL PROPERTY RIGHT.**

**UNLESS EXPRESSLY APPROVED IN WRITING BY AN AUTHORIZED ST REPRESENTATIVE, ST PRODUCTS ARE NOT RECOMMENDED, AUTHORIZED OR WARRANTED FOR USE IN MILITARY, AIR CRAFT, SPACE, LIFE SAVING, OR LIFE SUSTAINING APPLICATIONS, NOR IN PRODUCTS OR SYSTEMS WHERE FAILURE OR MALFUNCTION MAY RESULT IN PERSONAL INJURY, DEATH, OR SEVERE PROPERTY OR ENVIRONMENTAL DAMAGE. ST PRODUCTS WHICH ARE NOT SPECIFIED AS "AUTOMOTIVE GRADE" MAY ONLY BE USED IN AUTOMOTIVE APPLICATIONS AT USER'S OWN RISK.**

Resale of ST products with provisions different from the statements and/or technical features set forth in this document shall immediately void any warranty granted by ST for the ST product or service described herein and shall not create or extend in any manner whatsoever, any liability of ST.

ST and the ST logo are trademarks or registered trademarks of ST in various countries.

Information in this document supersedes and replaces all information previously supplied.

The ST logo is a registered trademark of STMicroelectronics. All other names are the property of their respective owners.

© 2008 STMicroelectronics - All rights reserved

STMicroelectronics group of companies

Australia - Belgium - Brazil - Canada - China - Czech Republic - Finland - France - Germany - Hong Kong - India - Israel - Italy - Japan - Malaysia - Malta - Morocco - Singapore - Spain - Sweden - Switzerland - United Kingdom - United States of America

[www.st.com](http://www.st.com)