



M39029/113
853-003
Size 8 Concentric Twinax Pin

D38999
Ser. I, III, IV

Size #8 Concentric Twinax Pin for MIL-DTL-38999 Series I, III and IV Connectors



These #8 concentric twinax pin contacts accept MIL-STD-1553 data bus twinax cable. Center and intermediate contacts are rated at 1 amp, the outer contact 12 amps. DWV rating is 500 Vac rms sea level, 125 Vac at 70,000 feet. Operating frequency is 0-20 MHz. Contacts are packaged individually and shipped unassembled with instruction sheet. One contact consists of outer contact, fluorocarbon dielectric, inner contact, intermediate contact and shield crimp bushing. All contacts are gold-plated copper alloy. Approved to SAE AS39029. 5000 megohm insulation resistance. Mates with: M39029/114.

Type	Cable Accommodation	Part Number	Military Part Number	Color Band		
				1st	2nd	3rd
Pin	M17/176-00002	853-003-08-625	M39029/113-625	Blue	Red	Green

**Table II - Tool
(Insertion and Extraction)**

M81969/14-12

Table III Tools (Crimping)

Center Contact Tooling		Intermediate Contact Tooling		Outer Crimp Sleeve Tooling	
Basic Crimping Tool	Contact Positioner	Basic Crimping Tool	Die Part No.	Basic Crimping	Die Part No.
M22520/2-01	M22520/2-37	M22520/5-01	M22520/5-105 Cavity B	M22520/5-01	M22520/5-105 Cavity A

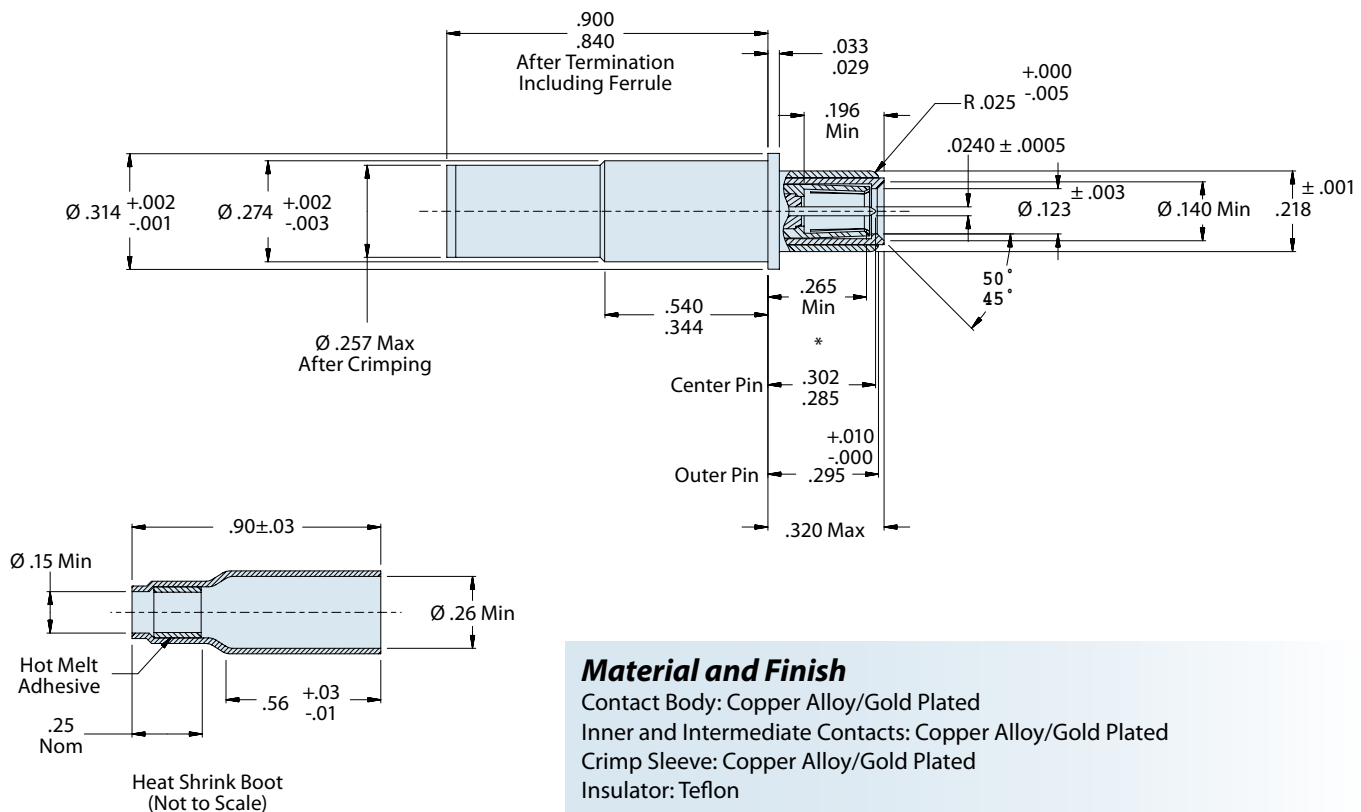

Material and Finish

Contact Body: Copper Alloy/Gold Plated
Inner and Intermediate Contacts: Copper Alloy/Gold Plated
Crimp Sleeve: Copper Alloy/Gold Plated
Insulator: Teflon