

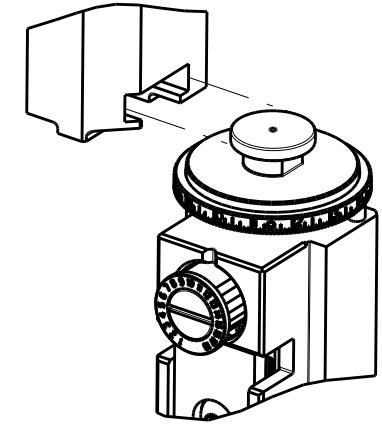



ATLANTIC VERSION TERMINATOR INTERFACE ADAPTER	PART NUMBER	REVISION	DESCRIPTION	FEED TYPE	APPLICATOR STYLE CONVERSION CHART					
					CONVERT TO	PART NUMBERS REQUIRED				
	2150403-2	A	FINE CRIMP HEIGHT ADJUST	PNEUMATIC	-	-	-	-	-	-
	2150403-5	A	FINE CRIMP HEIGHT ADJUST	SERVO LATCH PLATE <sup>4</sup>	SERVO LATCH PLATE SMART APPLICATOR	2119951-1	1803052-1	8-2150403-5	-	2168400-7 (QUANTITY 2)
	2150403-6	A	NON-CRIMP HEIGHT ADJUST	SERVO LATCH PLATE <sup>11</sup>	-	-	-	-	-	-
	2150403-7	A	FINE CRIMP HEIGHT ADJUST	NONE	-	-	-	-	-	-
	7-2150403-7	A	CRIMP TOOLING KIT	-	-	-	-	-	-	-

APPLICATOR DATA		
CRIMP SIZE	TYPE	
WIRE 2.29 mm [.090]	F	
INSUL 3.05 mm [.120]	F	

APPLICATOR INSTRUCTIONS 408-10390 

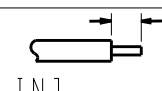
TERMINAL DATA: STOCKO/LNX TERMINAL TE CRIMP SPECIFICATION			
TERMINAL NAME: TERMINAL, TAB 6.3			
WIRE STRIP LENGTH		INSULATION DIAMETER RANGE	
5.80-6.60 mm [.228-.260 IN]		Ø1.52-2.54 mm [.060-.100 IN]	
TERMINAL APPLICATION SPECIFICATION	NONE		
TERMINALS APPLIED <sup>10</sup>			
TE TERMINAL	STOCKO/LNX TERMINAL	TE TERMINAL	STOCKO/LNX TERMINAL
1572348-1	7831.010.Z6.3-1		

WIRE SIZE	CRIMP HEIGHT mm [INCH]	CRIMP HEIGHT REFERENCE SETTING
1.50mm2	1.75+/-0.03 [.069+/-0.001]	5.4
1.00mm2	1.55+/-0.03 [.061+/-0.001]	7.5
0.75mm2	1.45+/-0.03 [.057+/-0.001]	8.7
0.50mm2	1.37+/-0.03 [.054+/-0.001]	9.4

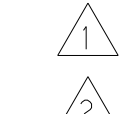
-  RECOMMENDED SPARE PARTS
-  GREASE BEARING SURFACES LIGHTLY
- 3. LUBRICATE DAILY PER THE APPLICATOR INSTRUCTION SHEET SUPPLIED WITH THE APPLICATOR.
- <sup>4</sup> APPLICATOR SPECIFIC DATA TO BE ENTERED INTO BLANK MEMORY CHIP AT ASSEMBLY. SEE BELOW FOR PART NUMBER:  
 PNEUMATIC FEED WITH "SMART APPLICATOR" CONVERSION: 8-2150403-4  
 SERVO FEED WITH "FINE CRIMP HEIGHT ADJUST": 8-2150403-5  
 SERVO FEED WITH "NON-CRIMP HEIGHT ADJUST": 8-2150403-6
- 5. ADJUSTMENT OF THE STRIPPER MAY BE REQUIRED WHEN MOVING THE APPLICATOR BETWEEN BENCH AND LEADMAKER APPLICATIONS.
- <sup>6</sup> APPLY PART NUMBER 1-23419-5 LOCTITE TO THREADS OF ITEMS 62, 180 & 242. FOR -6 ONLY APPLY PART NUMBER 1-23419-5 LOCTITE TO THREADS OF ITEMS 37, 180 & 242.
- <sup>7</sup> GREASE THREADS, GROOVE AND O-RING ON ITEMS 35 & 252.
- <sup>8</sup> MAGNET, ITEM 166 MUST BE ORIENTED CORRECTLY IN ORDER TO PROPERLY ACTUATE THE COUNTER.
- <sup>9</sup> CRIMP HEIGHT REFERENCE SETTING WAS THE SETTING USED WHEN THE APPLICATOR WAS QUALIFIED AT THE FACTORY. ADJUSTMENT MAY BE NECESSARY WHEN RUNNING APPLICATOR IN THE FIELD.
- <sup>10</sup> TERMINAL PITCH NOT COMPATIBLE WITH MECHANICAL FEED.
- <sup>11</sup> WHEN ASSEMBLING -6 NON-CRIMP HEIGHT ADJUST APPLICATOR USE SHIM PACK 2119957-2 TO ALIGN APPLICATOR'S MAXIMUM WIRE CRIMP HEIGHT AT NORMAL TERMINATOR SHUT HEIGHT

**\*WARNING**  
 ON INSTALLATION, SET WIRE DISC, ITEM 40 TO LARGEST WIRE SIZE SETTING. USE OF SETTINGS BELOW MINIMUM REQUIRED CRIMP HEIGHT SETTING WILL CAUSE DAMAGE TO CRIMP TOOLING.

-	-	1	-	-	2119957-2	APPLICATOR SHIM PACK	260
-	1	-	1	1	8-21084-0	O-RING, .676 ID, .070 DIA. MAT.	252
-	-	-	-	1	2119640-1	PUSH ROD, AIR FEED	250
-	-	-	-	1	2079988-1	BUSHING, LCH5-12, MISUMI	249
-	-	-	-	1	2119641-1	FEED CAM, AIR FEED	248
-77	-7	-6	-5	-2	PART NO	DESCRIPTION	ITEM NO

**ATLANTIC VERSION**  
 Shown on sheets 1 of 4 & 2 of 4  
 (Pacific version shown on sheets 3 of 4 & 4 of 4)

SET UP GAUGE	LOC	DIST	REVISIONS			
2119999-2	A	66	REV	DATE	BY	APPV
			A	RELEASED	17JAN2014	KH UG

-	1	-	1	1	2119798-1	DETENT PIN	247
-	1	-	1	1	1-22279-3	SPRING, COMPRESSION	246
-	-	1	-	-	2119759-1	RAM, AMP STYLE, END FEED, NON-ADJUST	245
-	1	1	1	1	2119082-9	CAM, SNAIL, INSULATION ADJUSTMENT	244
-	1	1	1	1	2079764-1	WASHER, WAVE SPRING, CREST-TO-CREST	243
-	1	1	1	1	2119083-1	RETAINER, INSULATION DIAL	242
-	-	2	2	-	2168400-7	SHCS, LOW HEAD, RoHS, M5 X 10	240
-	-	-	-	1	2063440-2	AIR FEED MODULE	238
-	-	1	1	-	2119740-2	TAG, IDENTIFICATION	213
-	-	REFREF	-	-	1803052-1	FEED FINGER ASSEMBLY, EF	183
-	1	1	1	1	1752354-1	STANDOFF, HOLD-DOWN	180
-	1	1	1	1	6-993111-6	PIN, SLOTTED SPRING 3.0 X 14.0	177
-	1	1	1	1	8-22280-7	SPRING, COMPRESSION	176
-	1	1	1	1	1752353-2	GUIDE PIN, HOLDDOWN	175
-	1	1	1	1	1901680-2	GUIDE PIN, HOLDDOWN	174
-	-	-	-	2	21045-3	RING, RETAIN, EXTERN, 3/16 CRESCENT	172
-	1	1	1	1	994969-1	MAGNET, RARE EARTH HIGH ENERGY	166
-	REFREF	REFREF	REFREF	REFREF	994970-2	COUNTER, MAGNETIC	164
-	-	-	-	1	240638-1	SPRING, FEED FINGER	163
-	-	-	-	1	3-23627-7	PIN, RETAIN, GRVD, 3/16 X .854	137
-	-	REFREF	-	-	SEE NOTE 4	MEMORY CHIP, PROGRAMMED	135
-	-	1	1	-	1633743-1	SERVO FEED LATCH ASM	133
-	1	1	1	1	455888-4	SPACER, CRIMPER	82
-	1	1	1	1	2119791-5	DEPRESSOR, WIRE	73
-	1	1	1	1	2119956-2	DOCUMENTATION PACKAGE	71
-	2	2	2	2	2-18032-2	SCR, SET, FLT POINT M3 X 10.0	70
-	1	1	1	1	2119943-1	WASHER, SPACER	69
-	1	-	-	1	2119740-1	TAG, IDENTIFICATION	67
-	2	2	2	2	2168078-1	SCREW, DRIVE, RH, RoHS, 2 x .188	66
-	1	1	1	1	1976052-1	HOLDDOWN, TERMINAL	65
-	1	-	1	1	2119793-1	LIMITER, ADJUSTMENT BOLT	63
-	3	-	3	3	992763-5	SCR, SET, SOC, CONE POINT, M3 X 4.0	62
-	1	1	1	1	2079383-4	SCR, BHSC, RoHS (M4 X 8)	60
-	4	4	4	4	2168400-4	SHCS, LOW HEAD, RoHS, M4 X 8	57
-	2	2	2	2	2168083-9	SCR, SKT HD CAP, RoHS, M4 X 20	56
-	2	2	2	2	5018030-2	NUT, HEX, REG, RoHS, M4	55
-	2	2	2	2	5018030-1	NUT, HEX, REG, RoHS, M3	54
-	2	2	2	2	986965-8	NUT, LOCK, HEX, TORQUE (M4)	53
-	1	1	1	1	1-5018030-0	NUT, HEX, REG, RoHS, M3.5	52
-	-	-	-	1	2119792-2	PAWL, EF, AIR	51
-	-	-	-	1	18023-9	SCR, SKT HD CAP M4 X 6.0	49
-	1	1	1	1	2119655-5	APPLICATOR BASIC ASSEMBLY, EF	46
-	1	-	1	1	2119369-1	RAM, AMP STYLE, END FEED	44
-	1	1	1	1	2079383-7	SCR, BHSC, RoHS (M8 X 25)	41
-	1	-	1	1	2119645-1	DISC, NUMBERED FA WIRE ADJUSTMENT	40
-	1	-	1	1	2119957-1	APPLICATOR SHIM PACK	39
-	1	1	1	1	1-2119644-2	RAM WASHER, PRECISION	38
-	1	1	1	1	2119085-1	FA HEAD, ATLANTIC STYLE	37
-	1	-	1	1	2119092-1	BOLT, ADJUSTMENT	35
-	8	8	8	8	1-18028-2	WASHER, FLAT, REG M4	33
-	2	2	2	2	2168083-9	SCR, SKT HD CAP, RoHS, M4 X 20	31
-	2	2	2	2	2168083-2	SCR, SKT HD CAP, RoHS, M4 X 8.0	29
-	1	1	1	1	240639-1	STRIPPER (MACHINING)	27
-	2	2	2	2	1320906-1	STUD, THREADED	25
-	1	1	1	1	1-1752371-2	PLATE, STRIP GUIDE	24
-	2	2	2	2	2-22281-3	SPRING, COMPRESSION	22
-	1	1	1	1	1752373-4	DRAG	20
-	1	1	1	1	1-1901696-8	STRIP GUIDE, REAR	19
-	1	1	1	1	1-1901695-8	STRIP GUIDE, FRONT	18
-	4	4	4	4	1-2079383-1	SCR, BHSC, RoHS (M6 X 12)	17
-	1	1	1	1	4-240641-7	SPACER	16
-	1	1	1	1	1752360-1	SPACER, HOLD-DOWN	13
-	1	1	1	1	240644-5	PLATE, REAR SHEAR	11
-	-	-	-	-	-	-	10
-	1	1	1	1	3-690482-2	PLATE, FRONT SHEAR	9
-	1	1	1	1	3-1333217-2	ANVIL, EF .090	8
-	1	1	1	1	1-2217206-0	BLADE, SLUG	7
-	-	-	-	-	-	-	6
-	1	1	1	1	1-240641-8	SPACER	5
-	1	1	1	1	238009-1	BLOCK, FL CRIMPER SPACER	4
-	1	1	1	1	1-1633961-9	CRIMPER, INSULATION F PREMIUM	3
-	2	2	2	2	455888-3	SPACER, CRIMPER	2
-	1	1	1	1	5-456406-7	CRIMPER, WIRE PREMIUM	1
-77	-7	-6	-5	-2	PART NO	DESCRIPTION	ITEM NO

DIMENSIONS:		TOLERANCES UNLESS OTHERWISE SPECIFIED:		DWG		NAME	
mm	0 PLC ±.5	1 PLC ±0.5	2 PLC ±0.13	3 PLC ±0.013	4 PLC ±0.001	ANGLES ±.001	FINISH
MATERIAL:				APV		DATE	
FINISH:				APV		DATE	
WEIGHT:				APV		DATE	
SCALE:				APV		DATE	

**STE** TE Connectivity  
 Harrisburg, PA 17105-3608

Ocean End Feed  
 Applicator

SIZE: A1 CAGE CODE: 00779 DRAWING NO: 2150403 SHEET 1 OF 4 REV A

LOC		DIST		REVISIONS			
A	66	P	LTM	DESCRIPTION	DATE	DWN	APVD
		-	-	SEE SHEET 1	-	-	-

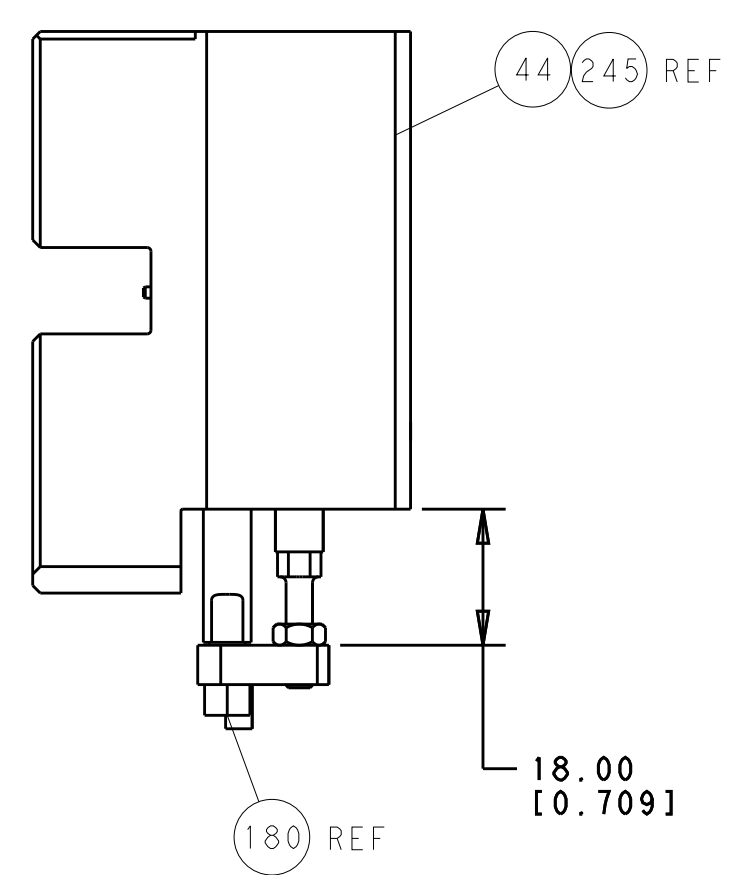

HOLDDOWN SET-UP

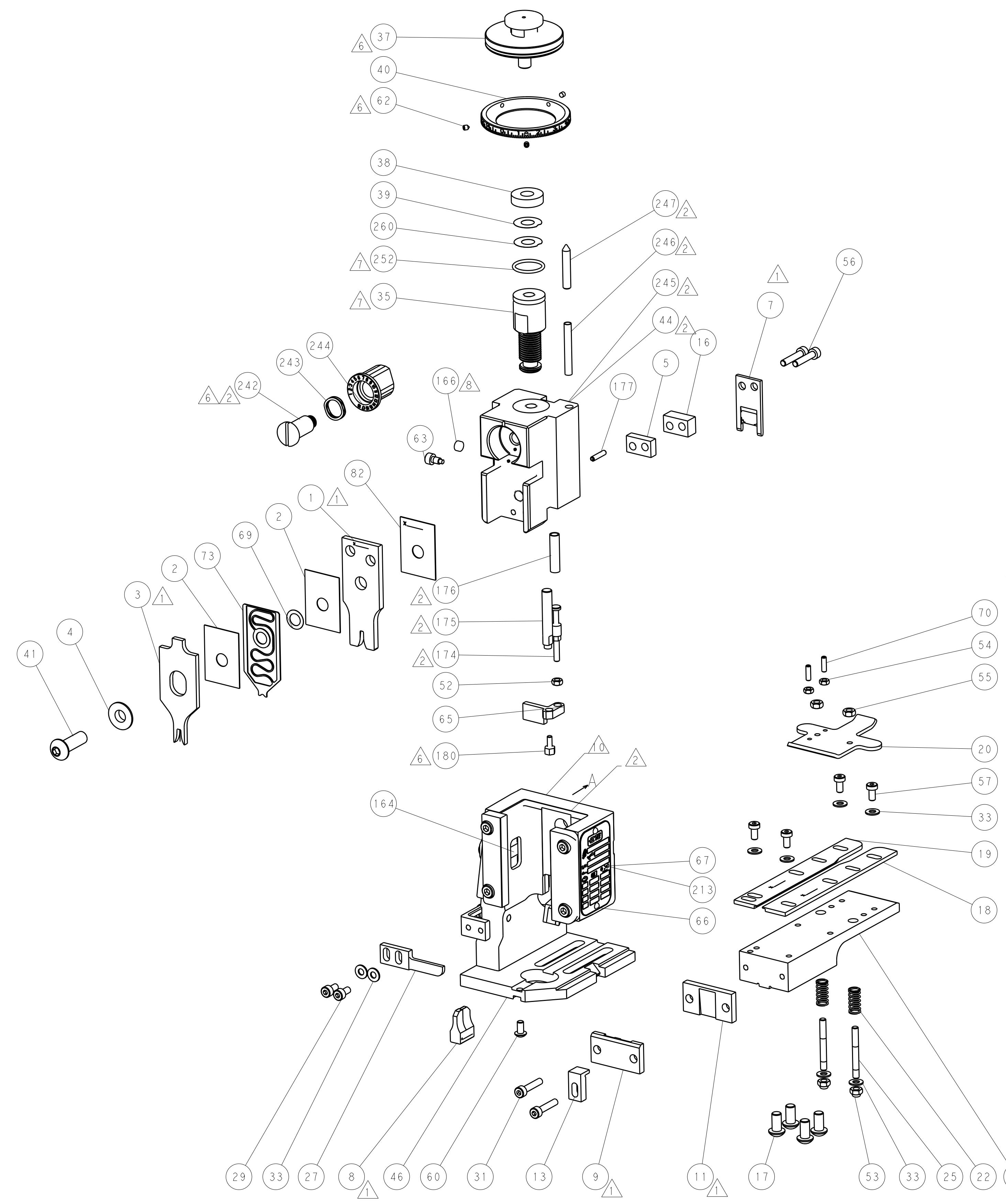

FEED TYPE

PNEUMATIC

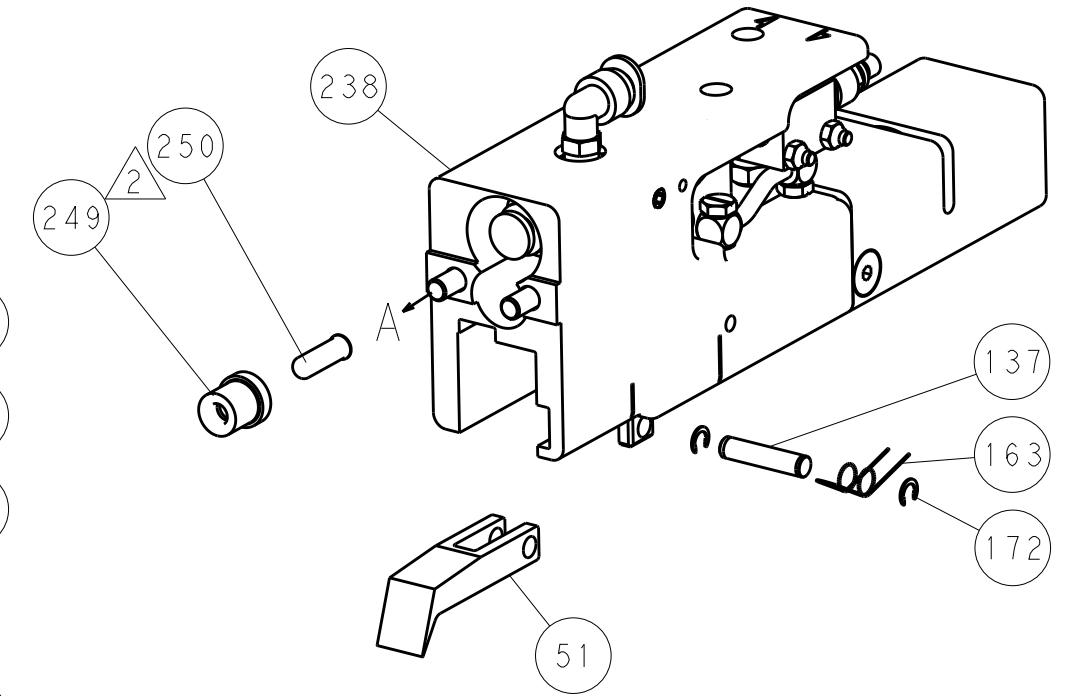

SERVO LATCH PLATE

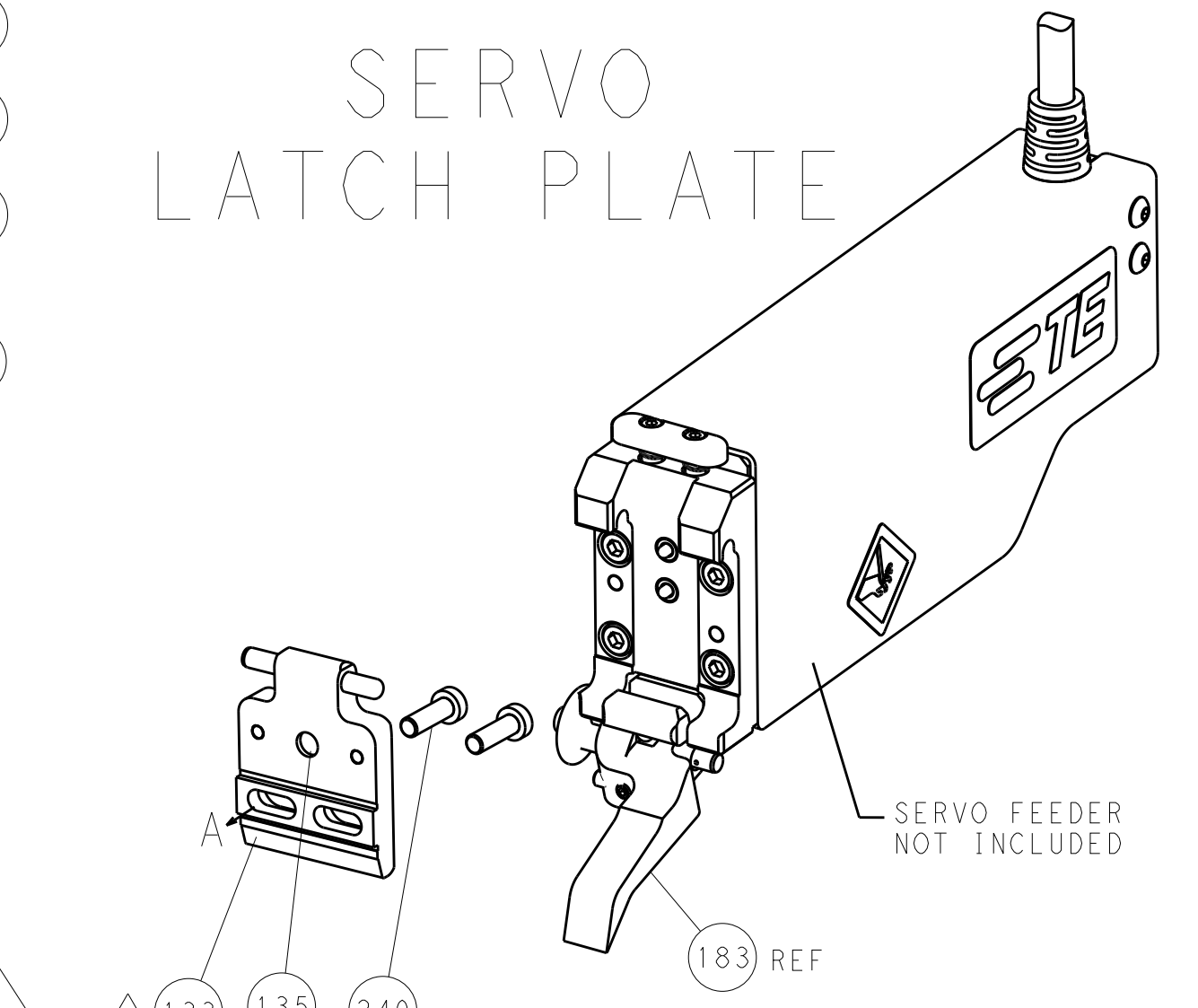

CAM POSITION

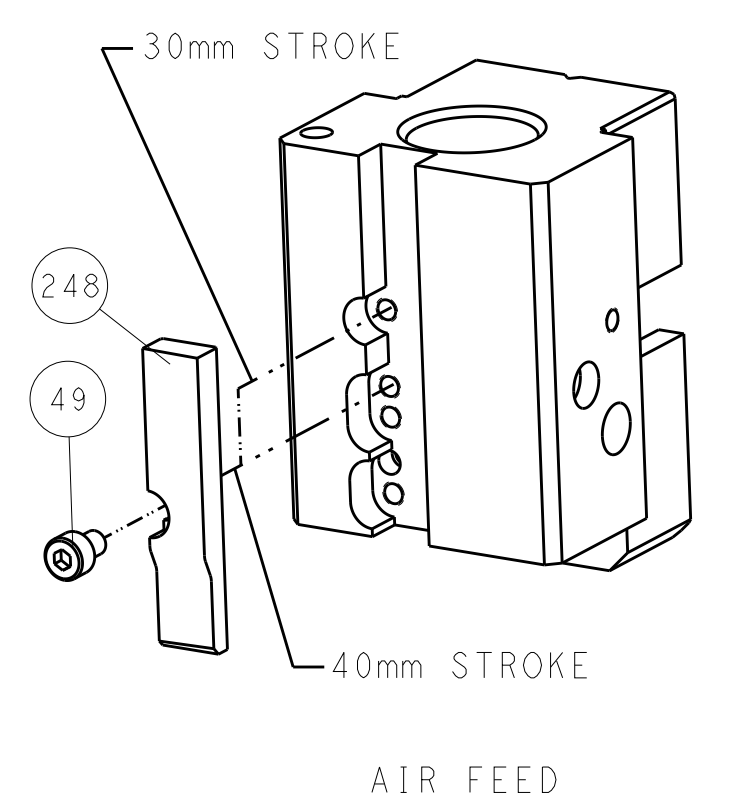

AIR FEED

ATLANTIC VERSION  
 Shown on sheets 1 of 4 & 2 of 4  
 (Pacific version shown on sheets 3 of 4 & 4 of 4)

<small>THIS DRAWING IS UNPUBLISHED. RELEASED FOR PUBLICATION BY TYCO ELECTRONICS CORPORATION. ALL RIGHTS RESERVED.</small>		DWN: H. HUANG 11DEC2013 CHK: L. ZHANG 11DEC2013 APVD: H. GUO 11DEC2013	TE Connectivity Harrisburg, PA 17105-3608
DIMENSIONS: mm TOLERANCES UNLESS OTHERWISE SPECIFIED: 0 PLC ±0.5 1 PLC ±0.5 2 PLC ±0.13 3 PLC ±0.013 4 PLC ±0.001 ANGLES ±0.001		NAME: Ocean End Feed Applicator PRODUCT SPEC: - APPLICATION SPEC: - WEIGHT: - SCALE: 1:1	RESTRICTED TO: - SIZE: A1 CAGE CODE: 00779 DRAWING NO: C=2150403 SHEET 2 OF 4 REV A
Customer Accessible Production Drawing			

PACIFIC VERSION TERMINATOR INTERFACE ADAPTER	PART NUMBER	REVISION	DESCRIPTION	FEED TYPE
	2-2150403-2	A	FINE CRIMP HEIGHT ADJUST	PNEUMATIC
	2-2150403-5	A	FINE CRIMP HEIGHT ADJUST	SERVO LATCH PLATE <sup>4</sup>
	2-2150403-7	A	FINE CRIMP HEIGHT ADJUST	NONE
	7-2150403-7	A	CRIMP TOOLING KIT	-

APPLICATOR DATA		
CRIMP	SIZE	TYPE
WIRE	2.29 mm (.090)	F
INSUL	3.05 mm (.120)	F
APPLICATOR INSTRUCTIONS 408-10390		

TERMINAL DATA: STOCKO/LNX TERMINAL TE CRIMP SPECIFICATION			
TERMINAL NAME: TERMINAL, TAB 6.3			
WIRE STRIP LENGTH		INSULATION DIAMETER RANGE	
5.80-6.60 mm (.228-.260 IN)		1.52-2.54 mm (.060-.100 IN)	
TERMINAL APPLICATION SPECIFICATION	NONE		
TERMINALS APPLIED <sup>10</sup>			
TE TERMINAL	STOCKO/LNX TERMINAL	TE TERMINAL	STOCKO/LNX TERMINAL
1572348-1	7831.010.Z6.3-1		

WIRE SIZE	CRIMP HEIGHT mm [INCH]	CRIMP HEIGHT REFERENCE SETTING <sup>9</sup>
1.50mm2	1.75 +/- 0.03 [.069 +/- .001]	5.4
1.00mm2	1.55 +/- 0.03 [.061 +/- .001]	7.5
0.75mm2	1.45 +/- 0.03 [.057 +/- .001]	8.7
0.50mm2	1.37 +/- 0.03 [.054 +/- .001]	9.4

- RECOMMENDED SPARE PARTS
- GREASE BEARING SURFACES LIGHTLY
- 3. LUBRICATE DAILY PER THE APPLICATOR INSTRUCTION SHEET SUPPLIED WITH THE APPLICATOR.
- <sup>4</sup> APPLICATOR SPECIFIC DATA TO BE ENTERED INTO BLANK MEMORY CHIP AT ASSEMBLY. SEE BELOW FOR PART NUMBER:  
PNEUMATIC FEED WITH "SMART APPLICATOR" CONVERSION: 8-2150403-4  
SERVO FEED WITH "FINE CRIMP HEIGHT ADJUST": 8-2150403-5
- 5. ADJUSTMENT OF THE STRIPPER MAY BE REQUIRED WHEN MOVING THE APPLICATOR BETWEEN BENCH AND LEADMAKER APPLICATIONS.
- <sup>6</sup> APPLY PART NUMBER 1-23419-5 LOCTITE TO THREADS OF ITEMS 62, 180 & 242.
- <sup>7</sup> GREASE THREADS, GROOVE AND O-RING ON ITEMS 139 & 153.
- <sup>8</sup> MAGNET, ITEM 166 MUST BE ORIENTED CORRECTLY IN ORDER TO PROPERLY ACTUATE THE COUNTER.
- <sup>9</sup> CRIMP HEIGHT REFERENCE SETTING WAS THE SETTING USED WHEN THE APPLICATOR WAS QUALIFIED AT THE FACTORY. ADJUSTMENT MAY BE NECESSARY WHEN RUNNING APPLICATOR IN THE FIELD.
- <sup>10</sup> TERMINAL PITCH NOT COMPATIBLE WITH MECHANICAL FEED.
- <sup>11</sup> THE RECOMMENDED SET-UP FOR END FEED APPLICATORS IS POST-FEED WITH ITEM 2119653-1. THE APPLICATOR CAN BE CONFIGURED FOR PRE-FEED WITH ITEM 2119652-1 BUT MAY ENCOUNTER PROBLEMS WITH SOME APPLICATIONS. FEED ISSUES OR TERMINAL JAMMING MAY OCCUR IN THE PRE-FEED CONFIGURATION.

**\*WARNING**  
ON INSTALLATION, SET WIRE DISC, ITEM 40 TO LARGEST WIRE SIZE SETTING. USE OF SETTINGS BELOW MINIMUM REQUIRED CRIMP HEIGHT SETTING WILL CAUSE DAMAGE TO CRIMP TOOLING.

-77-27-25-22	PART NO	DESCRIPTION	ITEM NO
- 1 1 1	2119782-1	FINE ADJUST HEAD ASM, PACIFIC STYLE	251
- - - 1	2119640-1	PUSH ROD, AIR FEED	250
- - - 1	2079988-1	BUSHING, LCH5-12, MISUMI	249
- 1 1 1	1-22279-3	SPRING, COMPRESSION	246
- 1 1 1	2119082-9	CAM, SNAIL, INSULATION ADJUSTMENT	244

**PACIFIC VERSION**  
Shown on sheets 3 of 4 & 4 of 4  
(Atlantic version shown on sheets 1 of 4 & 2 of 4)

SET UP GAUGE	LOC	DIST	REVISIONS			
2119599-2	A	66	REV	DATE	BY	APPV
			-	SEE SHEET 1	-	-

REV	DATE	BY	APPV	DESCRIPTION	ITEM NO
- 1 1 1	2079764-1			WASHER, WAVE SPRING, CREST-TO-CREST	243
- 1 1 1	2119083-1			RETAINER, INSULATION DIAL	242
- - 2 -	2168400-7			SHCS, LOW HEAD, RoHS, M5 X 10	240
- - - 1	2063440-2			AIR FEED MODULE	238
- - 1 -	2119740-2			TAG, IDENTIFICATION	213
- 4 4 4	2079383-9			SCR, BHSC, RoHS (M6 X 20)	186
- - REF -	1803052-1			FEED FINGER ASSEMBLY, EF	183
- 1 1 1	1752354-1			STANDOFF, HOLD-DOWN	180
- 1 1 1	6-993111-6			PIN, SLOTTED SPRING 3.0 X 14.0	177
- 1 1 1	8-22280-7			SPRING, COMPRESSION	176
- 1 1 1	1752353-2			GUIDE PIN, HOLDDOWN	175
- 1 1 1	1901680-2			GUIDE PIN, HOLDDOWN	174
- - - 2	21045-3			RING, RETAIN, EXTERN, 3/16 CRESCENT	172
- 1 1 1	994969-1			MAGNET, RARE EARTH HIGH ENERGY	166
- REFREFREF	994970-2			COUNTER, MAGNETIC	164
- - - 1	240638-1			SPRING, FEED FINGER	163
- 1 1 1	8-21084-1			O-RING, .801 ID, .070 DIA. MAT.	153
- - - 1	2119641-2			FEED CAM, AIR FEED	152
- 1 1 1	2119798-2			DETENT PIN	145
- 1 1 1	2079383-8			SCR, BHSC, RoHS (M4 X 16)	144
- 1 1 1	2119655-6			APPLICATOR BASIC ASSEMBLY, EF	141
- 1 1 1	2119651-1			RAM, ASIAN STYLE, END FEED	140
- 1 1 1	2119092-2			BOLT, ADJUSTMENT	139
- - - 1	3-23627-7			PIN, RETAIN, GRVD, 3/16 X .854	137
- - REF -	SEE NOTE 4			MEMORY CHIP, PROGRAMMED	135
- - 1 -	1633743-1			SERVO FEED LATCH ASM	133
- 1 1 1	455888-4			SPACER, CRIMPER	82
- 1 1 1	2119791-5			DEPRESSOR, WIRE	73
- 1 1 1	2119956-2			DOCUMENTATION PACKAGE	71
- 2 2 2	2-18032-2			SCR, SET, FLT POINT M3 X 10.0	70
- 1 1 1	2119943-1			WASHER, SPACER	69
- 1 - 1	2119740-1			TAG, IDENTIFICATION	67
- 2 2 2	2168078-1			SCREW, DRIVE, RH, RoHS, 2 x .188	66
- 1 1 1	1976052-1			HOLDDOWN, TERMINAL	65
- 1 1 1	2119793-1			LIMITER, ADJUSTMENT BOLT	63
- 3 3 3	992763-5			SCR, SET, SOC, CONE POINT, M3 X 4.0	62
- - - -	5-18022-5			SCR, HEX HD CAP, M4 X 6.0	59
- - - -	2063961-1			FEED FINGER	58
- 4 4 4	2168400-4			SHCS, LOW HEAD, RoHS, M4 X 8	57
- 2 2 2	2168083-9			SCR, SKT HD CAP, RoHS, M4 X 20	56
- 2 2 2	5018030-2			NUT, HEX, REG, RoHS, M4	55
- 2 2 2	5018030-1			NUT, HEX, REG, RoHS, M3	54
- 2 2 2	986965-8			NUT, LOCK, HEX, TORQUE (M4)	53
- 1 1 1	1-5018030-0			NUT, HEX, REG, RoHS, M3.5	52
- - - 1	2119792-2			PAWL, EF, AIR	51
- - - 1	18023-9			SCR, SKT HD CAP M4 X 6.0	49
- 1 1 1	2079383-7			SCR, BHSC, RoHS (M8 X 25)	41
- 1 1 1	2119645-1			DISC, NUMBERED FA WIRE ADJUSTMENT	40
- 1 1 1	2119957-1			APPLICATOR SHIM PACK	39
- 1 1 1	1-2119644-2			RAM WASHER, PRECISION	38
- 8 8 8	1-18028-2			WASHER, FLAT, REG M4	33
- 2 2 2	2168083-9			SCR, SKT HD CAP, RoHS, M4 X 20	31
- 2 2 2	2168083-2			SCR, SKT HD CAP, RoHS, M4 X 8.0	29
- 1 1 1	240639-1			STRIPPER (MACHINING)	27
- 2 2 2	1320906-1			STUD, THREADED	25
- 1 1 1	1-1752371-2			PLATE, STRIP GUIDE	24
- 2 2 2	2-22281-3			SPRING, COMPRESSION	22
- 1 1 1	1752373-4			DRAG	20
- 1 1 1	1-1901696-8			STRIP GUIDE, REAR	19
- 1 1 1	1-1901695-8			STRIP GUIDE, FRONT	18
- 1 1 1	4-240641-7			SPACER	16
- 1 1 1	1752360-1			SPACER, HOLD-DOWN	13
- 1 1 1	240644-5			PLATE, REAR SHEAR	11
- - - -	-			-	10
- 1 1 1	3-690482-2			PLATE, FRONT SHEAR	9
1 1 1 1	3-1333217-2			ANVIL, EF .090	8
- 1 1 1	1-2217206-0			BLADE, SLUG	7
- - - -	-			-	6
- 1 1 1	1-240641-8			SPACER	5
- 1 1 1	238009-1			BLOCK, FL CRIMPER SPACER	4
1 1 1 1	1-1633961-9			CRIMPER, INSULATION F PREMIUM	3
- 2 2 2	455888-3			SPACER, CRIMPER	2
1 1 1 1	5-456406-7			CRIMPER, WIRE PREMIUM	1

DIMENSIONS:		TOLERANCES UNLESS OTHERWISE SPECIFIED:		DWG: H. HUANG 11DEC2013		CHK: L. ZHANG 11DEC2013		DWN: H. HUANG 11DEC2013		NAME: TE Connectivity Harrisburg, PA 17105-3608	
mm	0 PLC ±.5	1 PLC ±0.5	2 PLC ±0.13	3 PLC ±0.013	4 PLC ±0.0001	ANGLES ±.0001	FINISH	APVD: H. GUO 11DEC2013	PRODUCT SPEC	APPLICATION SPEC	SIZE: CAGE CODE: DRAWING NO: RESTRICTED TO
MATERIAL:								WEIGHT:	A1 00779	©=2150403	SCALE: 1:1 SHEET 3 OF 4 REV A
Customer Accessible Production Drawing											

LOC		DIST		REVISIONS			
A	66	P	LTM	DESCRIPTION	DATE	OWN	APVD
		-	-	SEE SHEET 1	-	-	-

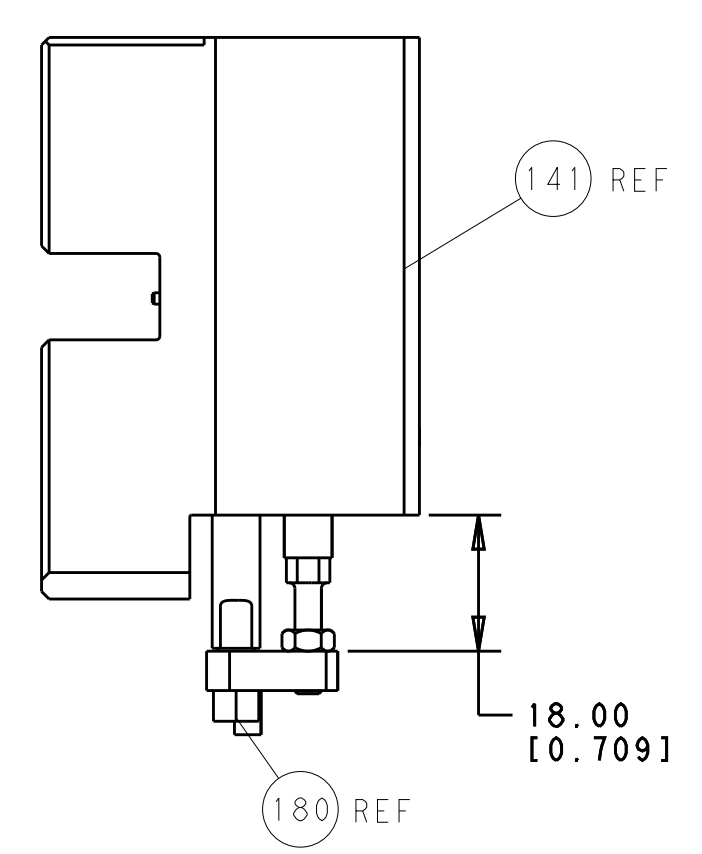

HOLDDOWN SET-UP

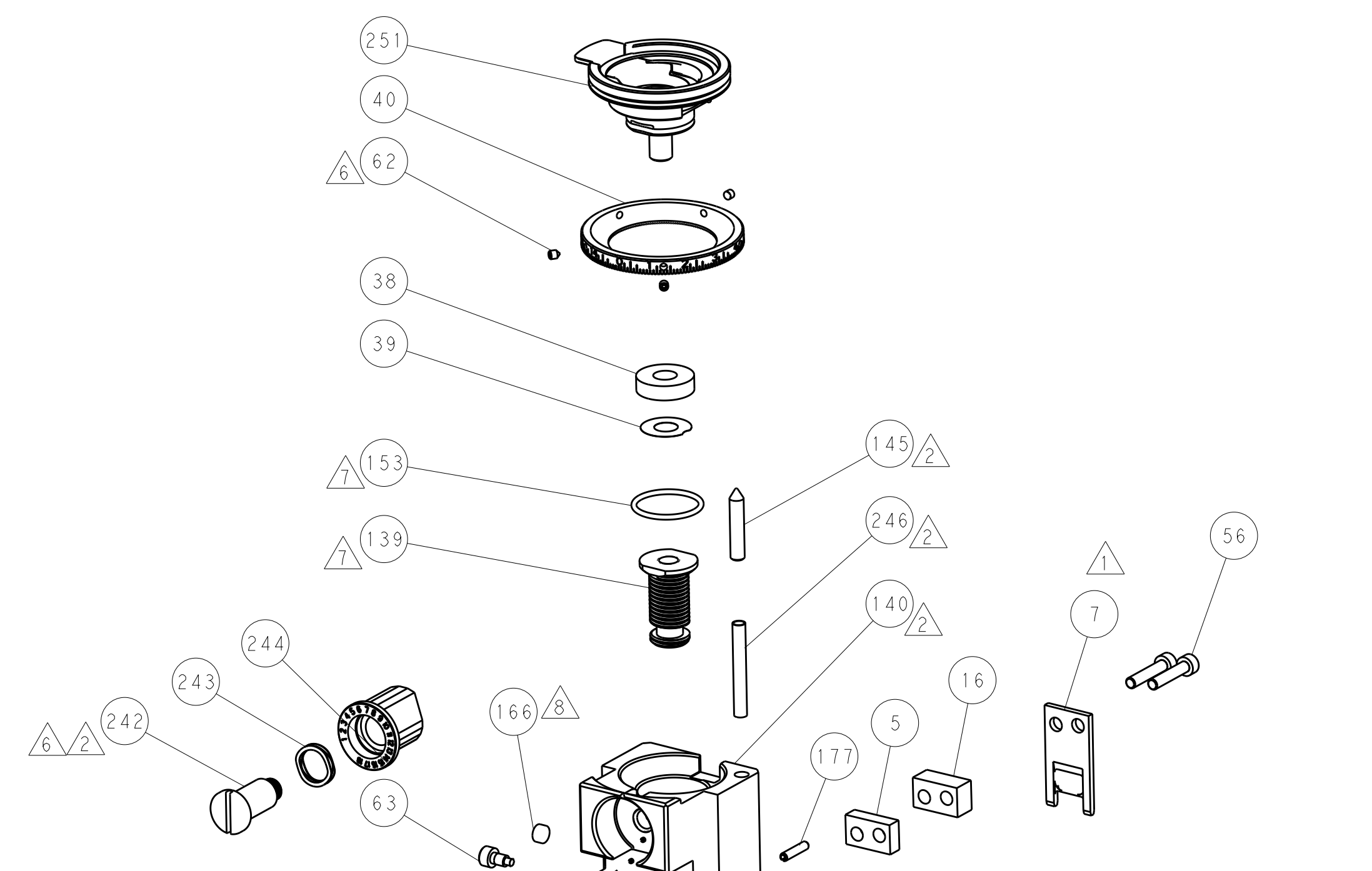

FEED TYPE

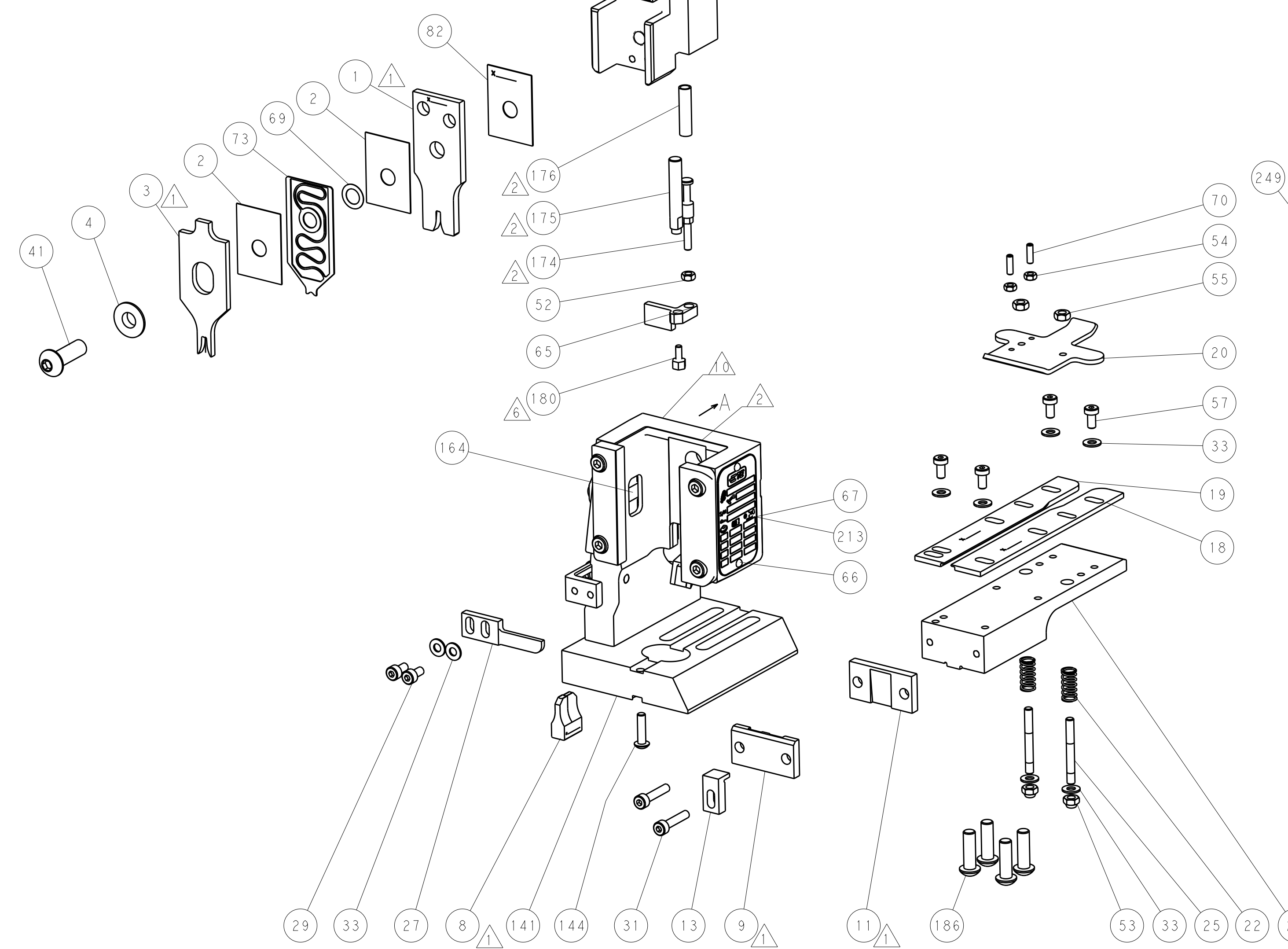

PNEUMATIC

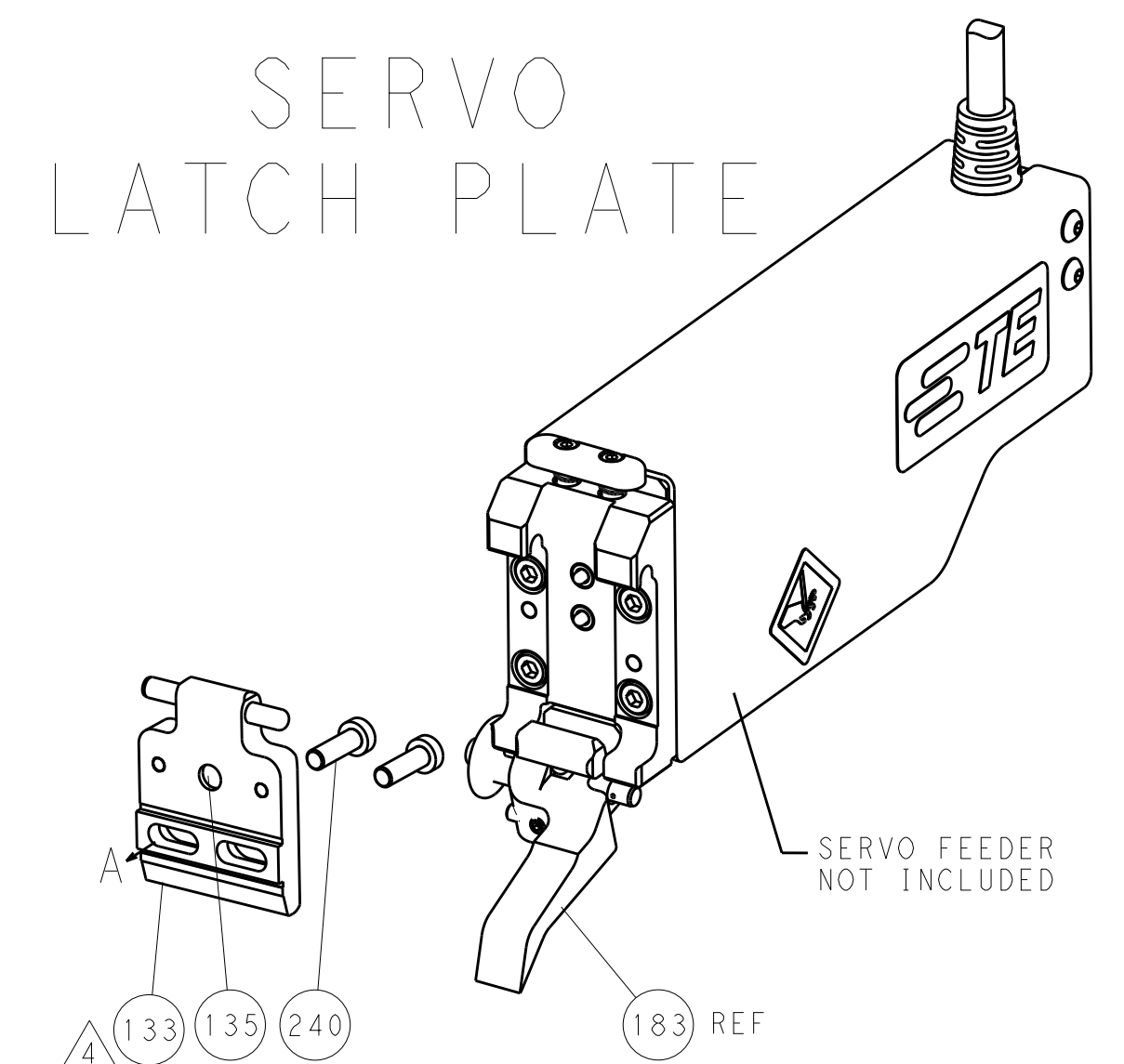

SERVO LATCH PLATE

CAM POSITION

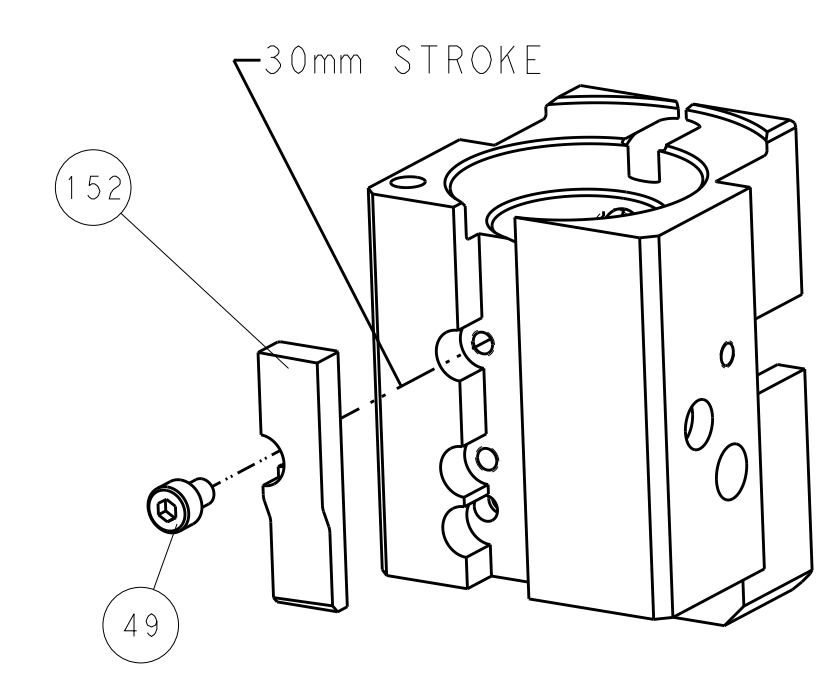

AIR FEED

**PACIFIC VERSION**  
 Shown on sheets 3 of 4 & 4 of 4  
 (Atlantic version shown on sheets 1 of 4 & 2 of 4)

<small>THIS DRAWING IS UNPUBLISHED. RELEASED FOR PUBLICATION. IT IS THE PROPERTY OF TYCO ELECTRONICS CORPORATION. IT IS TO BE USED ONLY FOR THE PURPOSES AND IN THE QUANTITIES SPECIFIED IN THE ORDER. IT IS TO BE RETURNED TO TYCO ELECTRONICS CORPORATION WHEN NO LONGER REQUIRED.</small>		DWN: H. HUANG 11DEC2013 CHK: L. ZHANG 11DEC2013 APVD: H. GUO 11DEC2013	TE Connectivity Harrisburg, PA 17105-3608
DIMENSIONS: mm TOLERANCES UNLESS OTHERWISE SPECIFIED: 0 PLC ±0.5 1 PLC ±0.5 2 PLC ±0.13 3 PLC ±0.013 4 PLC ±0.0013 ANGLES ±0.0013		PRODUCT SPEC APPLICATION SPEC WEIGHT Customer Accessible Production Drawing	NAME: Ocean End Feed Applicator SIZE: A1 CAGE CODE: 00779 DRAWING NO: C=2150403 SCALE: 1:1 SHEET: 4 of 4 REV: A