

EK-SA50

INTRODUCTION

Fast, easy breadboarding of circuits using the SA50 are possible with the EK-SA50 PC board. Mounting holes are provided and the provision for standard banana jacks simplifies connection and testing. Components are labeled on both sides of the board for ease in probing.

TYPICAL COMPONENT FUNCTIONS

- C2, C3, C4** Power supply bypass capacitors
- R3, R4** Resistor divider to set the input voltage at 50% of Vcc under nominal conditions
- R5, C1** Snubber network
- R1, R2** Current sensing resistors or jumpered to ground

PARTS LIST

| Part # | Description | Quantity |
|--------|-----------------|-------------|
| EVAL05 | P.C. Board | 1 |
| HS14 | Heatsink | 1 |
| MS03 | Mating Socket | 1 |
| TW03 | Thermal Washers | 1 bag of 10 |

EQUIVALENT SCHEMATIC

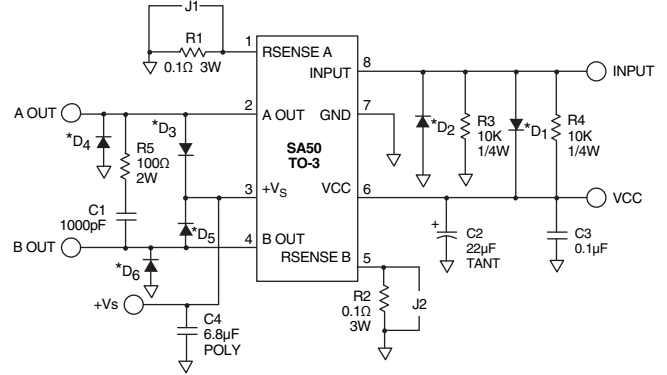

*D1 and D2 – Input protection, high speed such as IN4148.
 D3 through D6 – Flyback protection, high speed (<200nS).
 Solder as close to SA50 as possible.

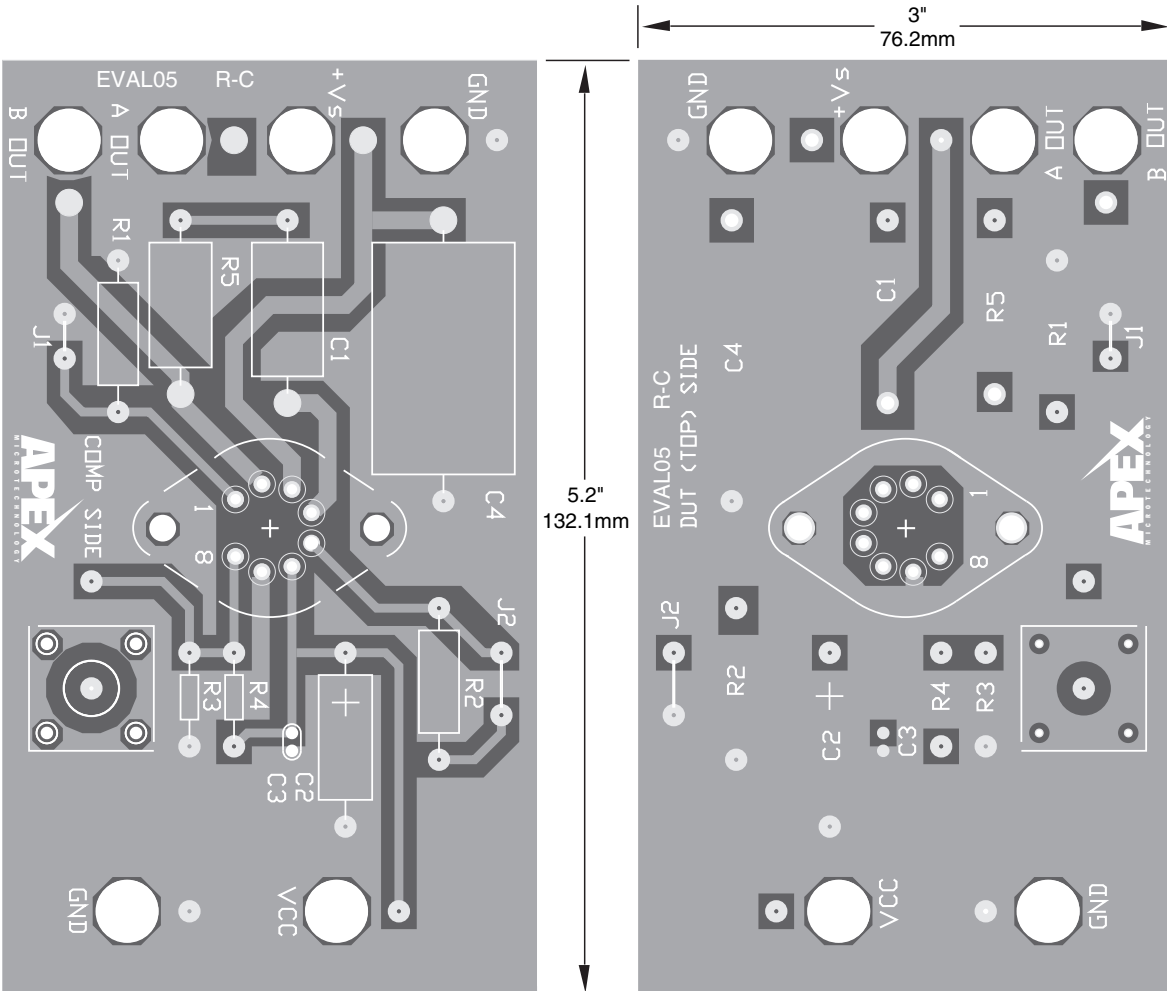

NOTE: Illustration only, not to exact scale.