

AsahiKASEI
ASAHI KASEI MICRODEVICES**AL2010****Current-Mode PWM Step-Down DC-DC Converter****GENERAL DISCRPTION**

AL2010 is the Current-Mode Synchronous Step-Down DC-DC Converter which offers excellent transient response. Output voltage is selectable between 0.8V and 5.0V by the external resistor. Input voltage range is between 3.0V and 5.5V, and it is the most suitable to generate 1.0V, 1.2V, and 1.8V. Power MOSFETs are built in AL2010, which is maximum current is 2.5A. The switching frequency is selectable between 300 kHz and 4 MHz by the external resistor. For the protections, AL2010 has Over-Current protection, Low-Input Voltage protection, and Power-Good function.

FEATURE**■ Step Down DCDC Converter**

- Input Voltage Range: 3.0V to 5.5V
- Output Voltage Range: 0.8V to 5.0V (by the external resistor)
- Maximum Output Load Current: 2.5A
- Operation Temperature: -40°C to 85°C
- Switching Frequency: 300kHz to 4MHz (Selectable by an external resistor. And Available External Synchronous Mode by the external clock)
- Low Input Voltage Protection
- Power-Good Function
- Over-Current Protection (Automatic recovery type)
- Thermal Protection
- Internal Reference Voltage: $\pm 1.5\%$ ($T_a = 25^\circ\text{C}$)
- Maximum Duty: 100%
- Soft Start Function
- PKG: TSSOPE-16

BLOCK DIAGRAM

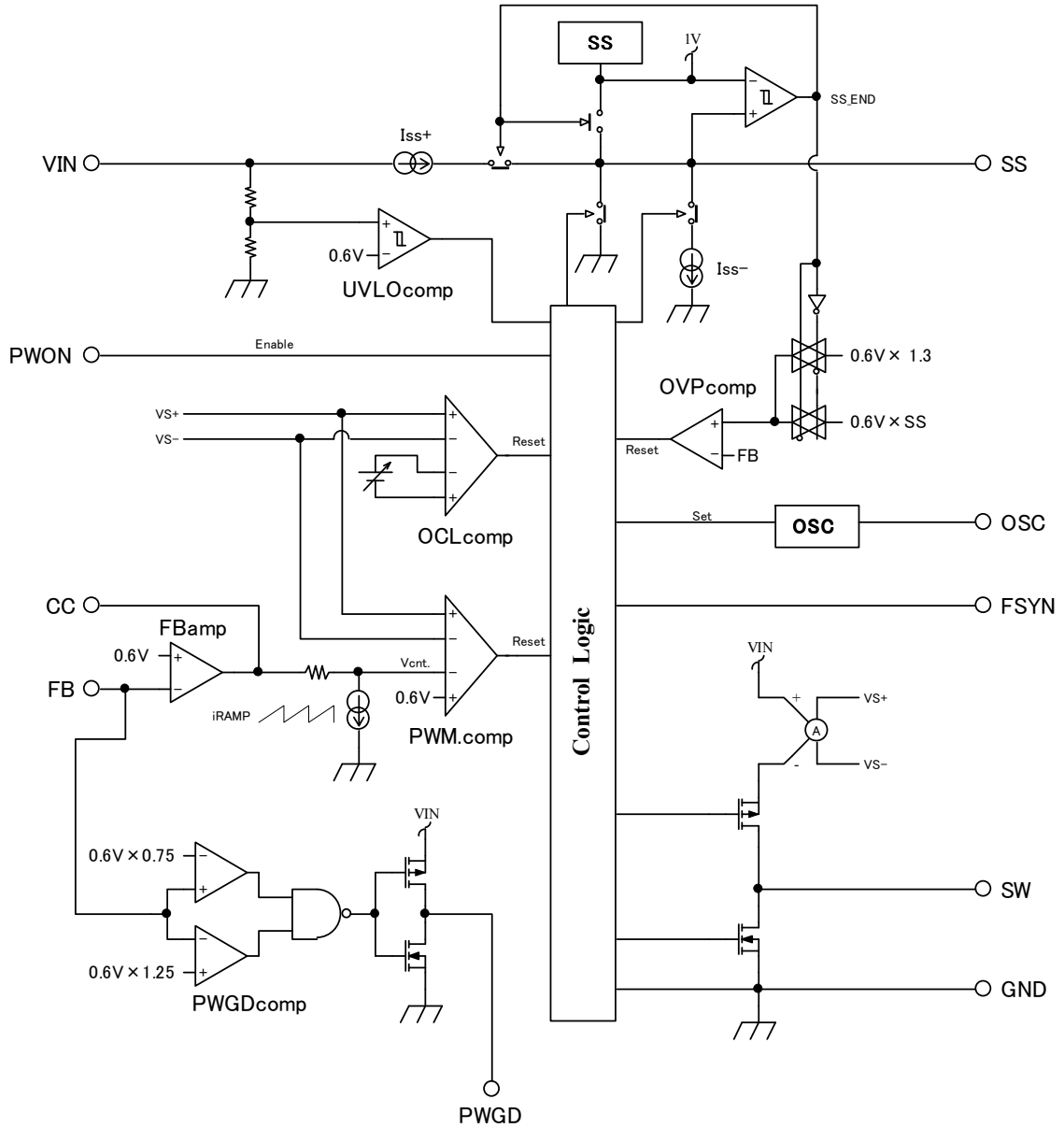

Figure 1. AL2010 Block Diagram

Pin Location & TYPICAL OPERATION CIRCUIT

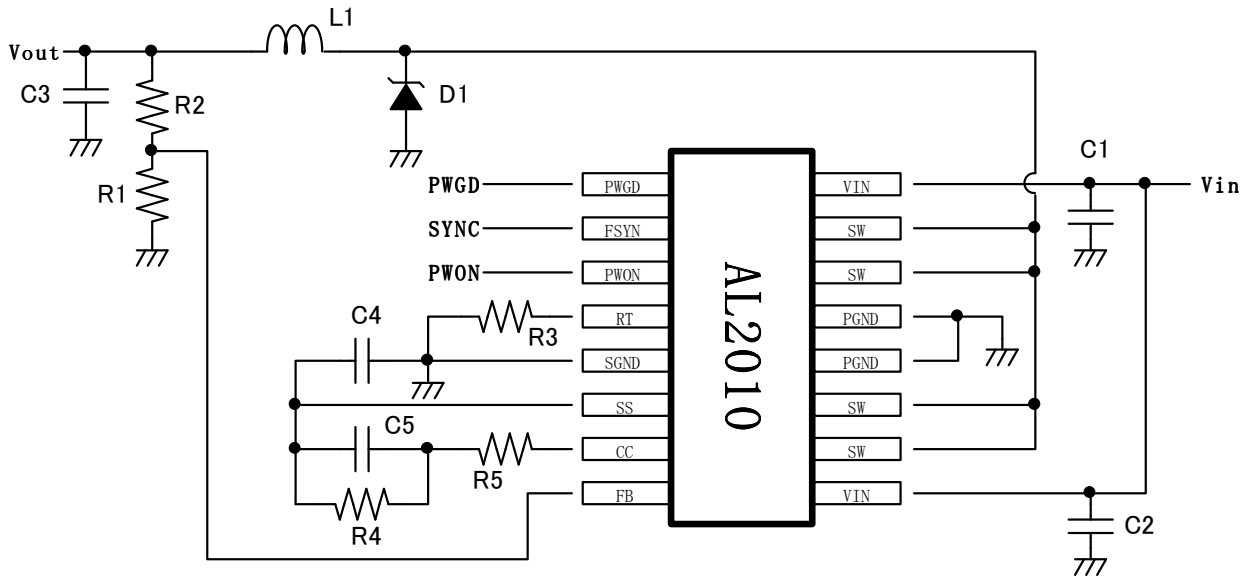

Figure 2. Pin Location (Top View)

PIN & FUNCTION

No.	Pin Name	Function	No.	Pin Name	Function
1	PWGD	Power-Good	9	VIN	Supply Input
2	FSYN	External Synchronous Clock Input	10	SW	Switching Node Output
3	PWON	Power-On	11	SW	Switching Node Output
4	RT	Frequency Setting	12	PGND	Power Ground
5	SGND	Signal Ground	13	PGND	Power Ground
6	SS	Soft Start	14	SW	Switching Node Output
7	CC	Output of Feedback Amplifier	15	SW	Switching Node Output
8	FB	Feedback Input	16	VIN	Supply Input

ABSOLUTE MAXIMUM RATING

(Gnd=0V; Note 1)

Parameter	Symbol	Min	Max	Units
VIN pin	VIN	-0.3	6.0	V
SW pin	VSW	-0.3	Vin + 0.3	V
All pins (Except SW pin, VIN pin)	VIND	-0.3	Vin	V
Junction Temperature	TJ		125	°C
Operating Ambient Temperature	TA	-40	85	°C
Storage Ambient Temperature	TSTG	-40	150	°C
Power Dissipation (Ta = 25°C)	Pd		2000	mW

Note1. All voltages with respect to ground.

WARNING: Operation at or beyond these limits may result in permanent damage to the device.

Normal operation is not guaranteed at these extremes.

RECOMMENDED OPERATING CONDITIONS

(Gnd=0V)

Parameter	Symbol	Min	Typ	Max	Units
VIN pin voltage	Vin	3.0	-	5.5	V
Output Current	Iout	0	-	2.5	A
Operating Ambient Temperature	Ta	-40	-	85	°C

*AKPD assumes no responsibility for the usage beyond the conditions in this datasheet.

ELECTRICAL CHARACTERISTICS

(Vin=5.0V, Ta=25°C, unless otherwise specified)

Parameter	Symbol	Conditions	Min	Typ	Max	Units
Operating Input Voltage Range	Vin		3.0	-	5.5	V
Feedback REF Voltage	V _{FB_ref}		591	600	609	mV
Operation Current Consumption	I _{SUPLY}	No Switching	0.48	0.8	1.12	mA
Stand-by Current	Istandby	Power-Off	-	-	10	μA
Load Regulation *1	ΔV _{LOAD}		-	1	-	%
MOSFET R _{DS(ON)}	R _{pmos}	PMOS R _{DS(ON)}	10	65	100	mΩ
	R _{nmos}	NMOS R _{DS(ON)}	10	65	100	mΩ
Over-Current Detection	Ioc _{peak}		3.15	4.5	-	A
Oscillator Frequency	fosc		300	-	4000	kHz
FSYN Input Frequency Range	Fext300	RT=702kΩ (at 300kHz)	240	-	360	kHz
	Fext2000	RT=100kΩ (at 2MHz)	1600	-	2400	kHz
Oscillator Accuracy	facu	RT=100kΩ (at 2MHz)	-20	0	20	%
Maximum ON Duty	MAXDuty	*2	-	-	100	%
UVLO	Vuvlo	Voltage at Lock	2.30	2.50	2.84	V
UVLO Return Voltage		Voltage at Release	2.36	2.70	2.90	V
UVLO (Hysteresis)	Vuv_hys	UVLO Hysteresis Width	0.06	0.20	-	V
Output Over Voltage Detection	Vovp	against V _{FB_ref}	+26	+30	+34	%
Charge Current (to Capacitor of Soft Start)	I _{ss+}	C _{ss} =0V → 1.0V (at rise)	18.0	20.0	22.0	μA
Discharge Current (to Capacitor of Soft Start)	I _{ss-}	C _{ss} =1.0V → 0.40V (at fall)	0.75	1.0	1.25	μA
Thermal Protection Detection *2			-	150	-	°C
Thermal Protection Hysteresis *2			-	15	-	°C
Power Good Detection		against V _{FB_ref}	±16	±20	±24	%
Power Good non-Detection		against V _{FB_ref}	±21	±25	±29	%
Power Good Hysteresis			±3	±5	±7	%
Power-ON Threshold	Vponl		-	-	0.4	V
Power-OFF Threshold	Vponh		1.5	-	-	V
Power-ON Hysteresis			50	100	150	mV
gm (CC pin)			400	500	600	μS

*1. For reference value by the recommended circuit

*2. Guaranteed by design and characterization

DC CHARACTERISTICS

(Ta=25°C, unless otherwise specified)

Parameter	Symbol	Condition	Min	Typ	Max	Units
FSYN(Input pin) Threshold Voltage	VEih		0.7*VDD	-	-	V
	VEil		-	-	0.3*VDD	V
PWGD(Output pin) Voltage	VPoh	I _{poh} =-100μA	VDD-0.4	-	-	V
	VPol	I _{pol} =100μA	-	-	0.4	V

RECOMMENDED CIRCUITRY & PCB LAYOUT

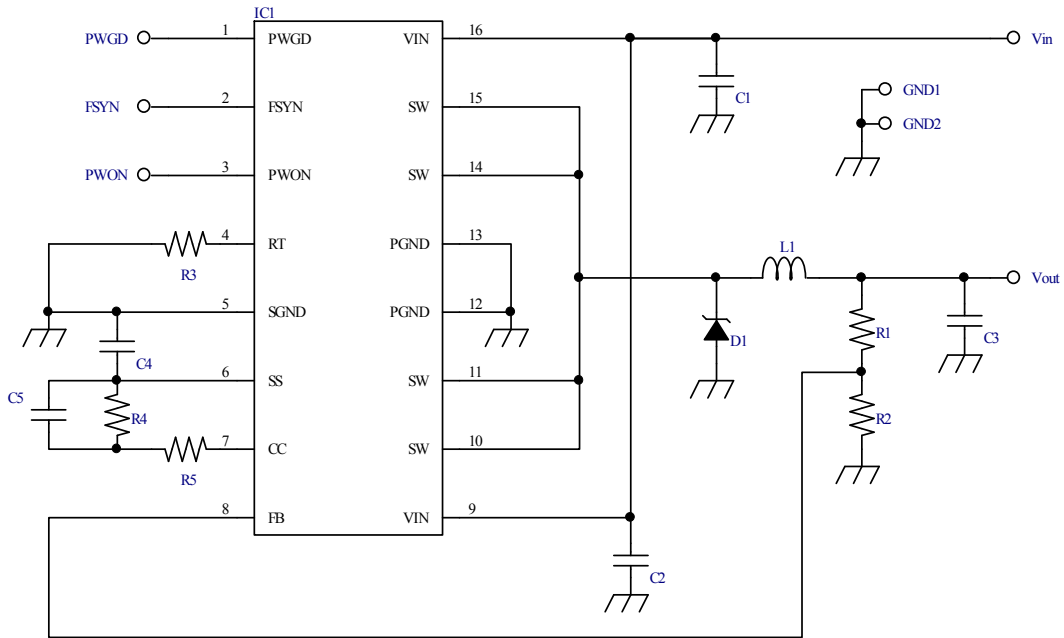

Figure 3. One Example of Recommended Circuitry

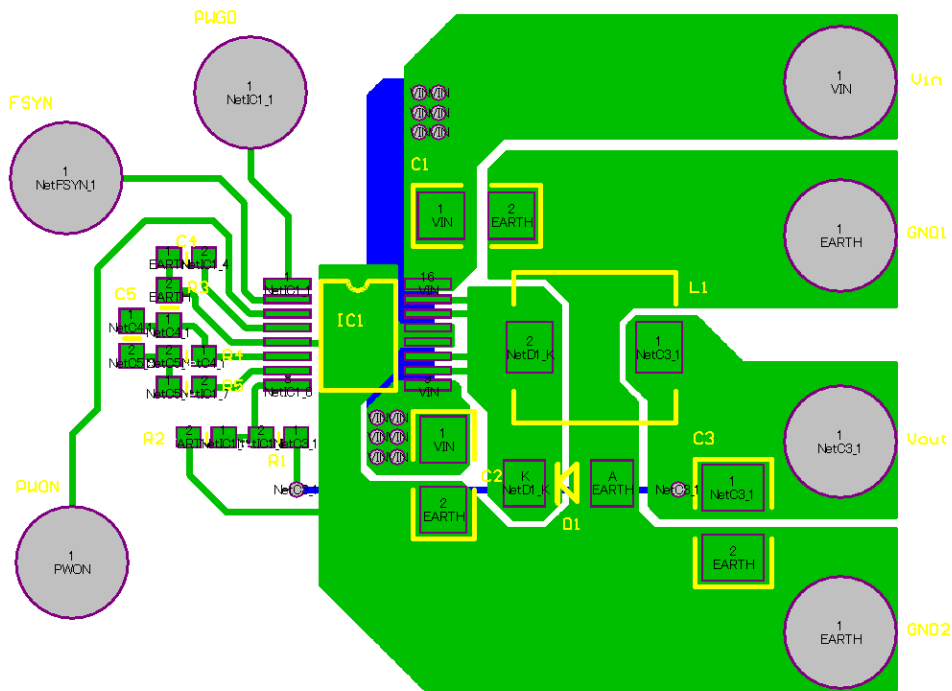

Figure 4. PCB LAYOUT

PIN DISCRPTION

1 pin_PWGD:

Power-Good pin. When the output voltage achieved to $\pm 20\%$ of set voltage, this pin becomes "Hi".

2 pin_FSYN:

External Synchronous Clock Input pin. Internal pull-up resistor is $300\text{k}\Omega$. The external clock within $\pm 20\%$ of relative value is available, which is to the internal clock, and it is set by the resistor at RT pin.

3 pin_PWON:

Power-ON pin. It starts in the voltage which is 1.5V and more.

4 pin_RT:

The setup pin of operation frequency. It is the setup by a resistor.

5 pin_SGND:

Signal Ground pin.

6 pin_SS:

Soft Start pin. It should connect the capacitor of $0.047\mu\text{F}$ and more between SS pin and GND. It charges an external capacitor at the time of startup, and Soft Start works. And, when the AL2010 is in the protection state of over current, the external capacitor is discharged and it makes the stop time in a hiccup operation.

7 pin_CC:

Output pin of Output Voltage Feedback Amplifier. A resistor and a capacitor are placed in a parallel connection, and those are connected between CC pin and Vref/SS pin. And those compensate a phase of an amplifier.

8 pin_FB:

Input pin of Output Voltage Feedback Amplifier. The voltage is controlled so that this pin voltage becomes 0.6V. Two resistors for the feedback should be placed in a series between the output stage and GND, and the connected point of two should be connected to FB pin.

9 pin, 16pin_VIN:

Input pin of Main Power Voltage. A capacitor should be placed between VIN pin and GND, which is $4.7\mu\text{F}$ and more.

10 pin, 11 pin, 14 pin, 15 pin_SW:

Output pin of the internal switching MOSFET.

12 pin, 13 pin_PGND:

Power Ground pin.

TIMING CHART AT START-UP

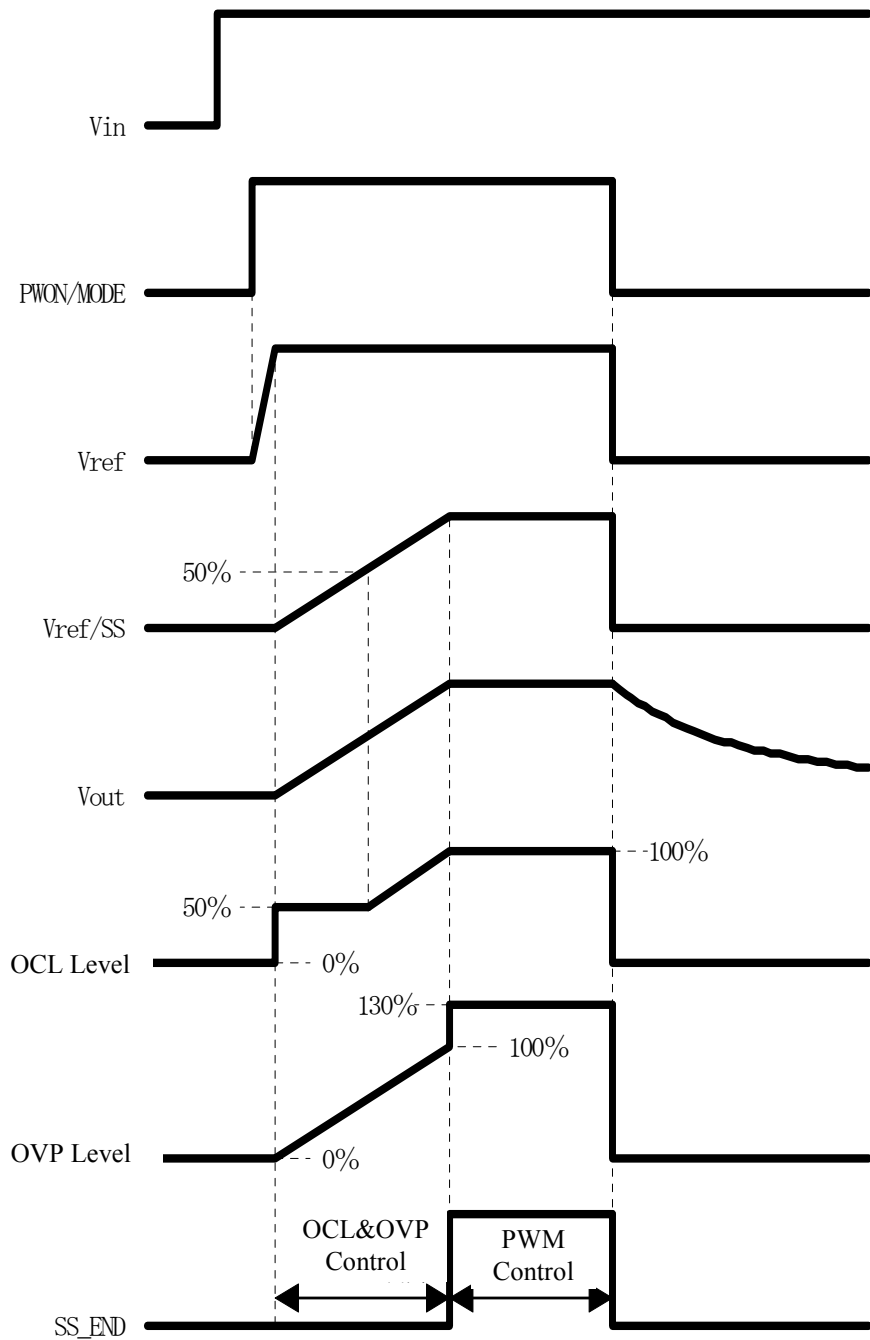
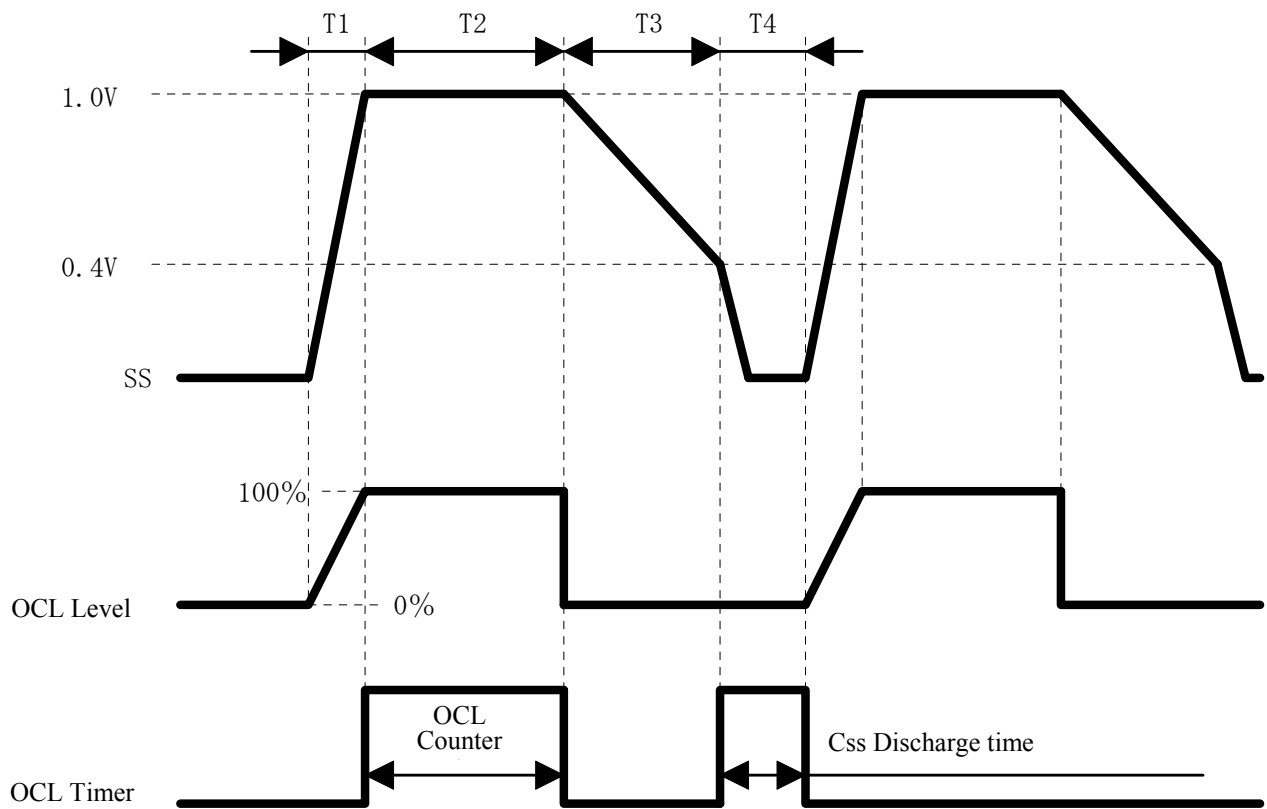

Figure 5. Start Up Timing

TIMING CHART AT OVER CURRENT PROTECTION



When $C_{ss}=0.1\mu F$, T1: Soft Start Time is 5ms, T3: Rest Time is 60ms,
 T2: 256 μs (512 clocks/2MHz) 、 T4: 192 μs (384 clock/2MHz)

When $C_{ss}=0.22\mu F$, T1: Soft Start Time is 11ms, T3: Rest Time is 132ms

Figure 6. Over Current Protection Timing

TIMING CHART BY EXTERNAL SYNCHRONOUS

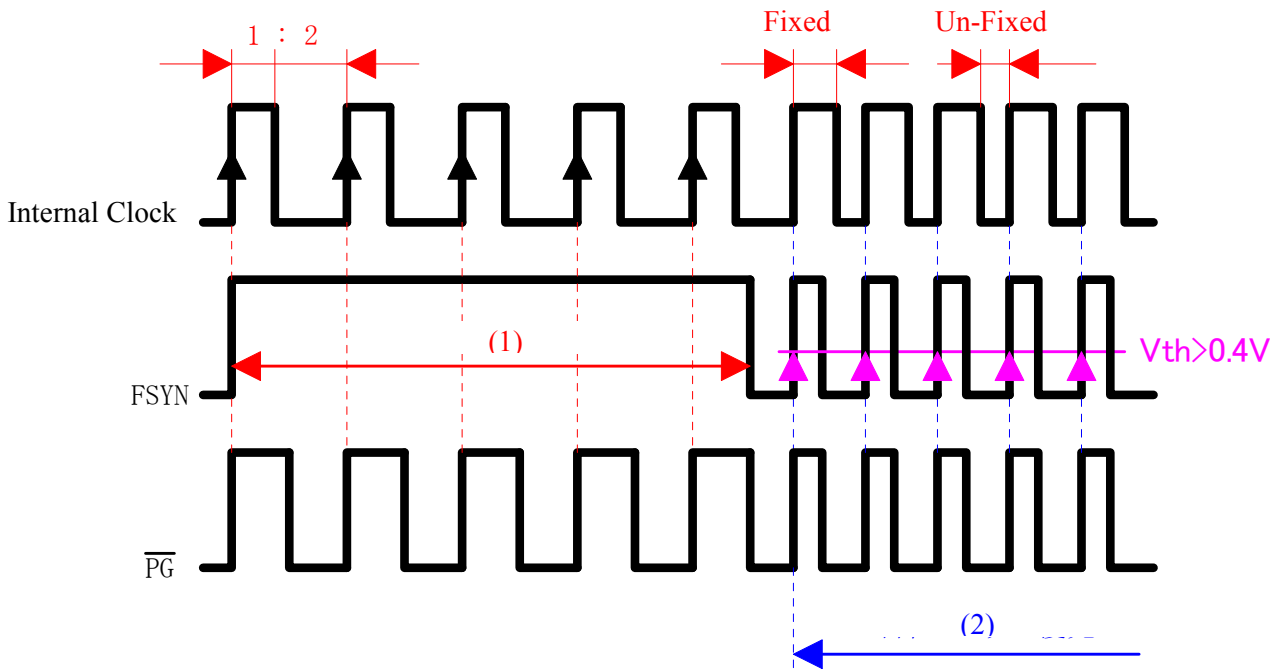

- (1) When the period of "FSYN=Hi" is longer than one cycle of Internal Clock, the operation clock is according to Internal Clock.
- (2) When the period of "FSYN=Hi" is shorter than one cycle of Internal Clock, the operation clock is according to External Clock.

The external clock which is as the relative value within $\pm 20\%$ of the internal clock frequency which depends on the resistor of RT pin can be inputted to AL2010.

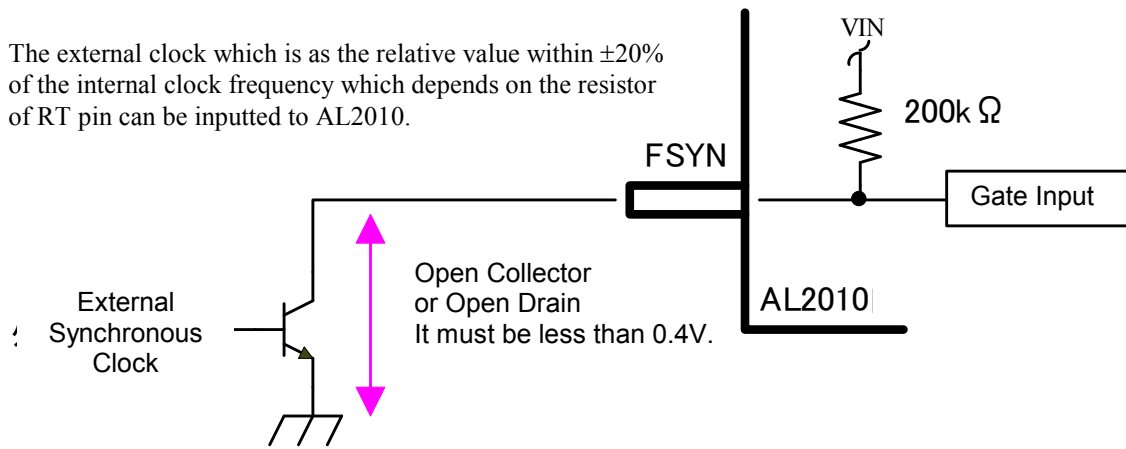
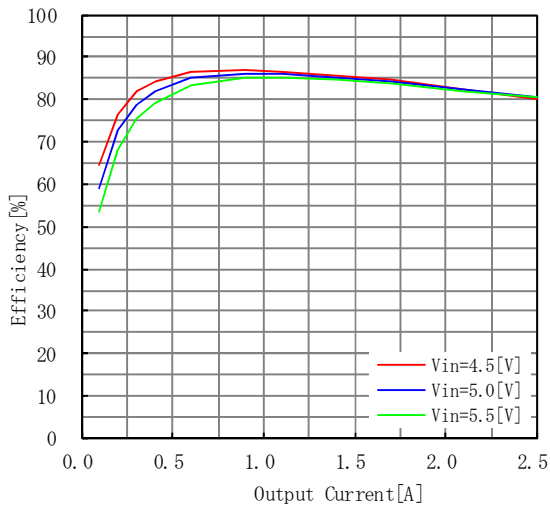
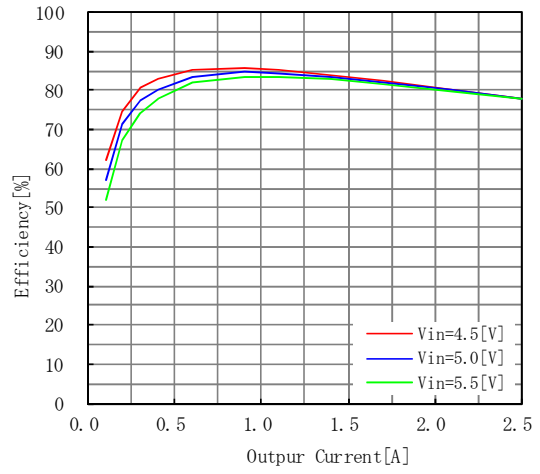

Figure 7. External Synchronous Timing

CHARACTERISTIC EXAMPLE



Vin=5V Vout=1.8V f=2.2MHz



Vin=5V Vout=1.5V f=2.0MHz

Figure 8. Characteristic Example

MARKING

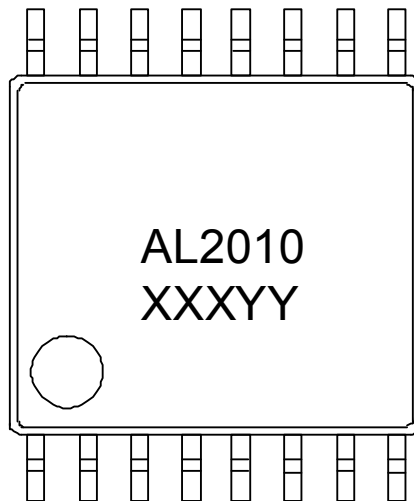

- 1) Pin #1 indication
- 2) Date Code : XXXYY (5 digits)
 XXX: Date Code
 YY: Lot#
- 3) Marketing Code : AL2010

Figure 9. Package Marking (Top View)

PACKAGE INFORMATION

16pin TSSOPE (Unit: mm)

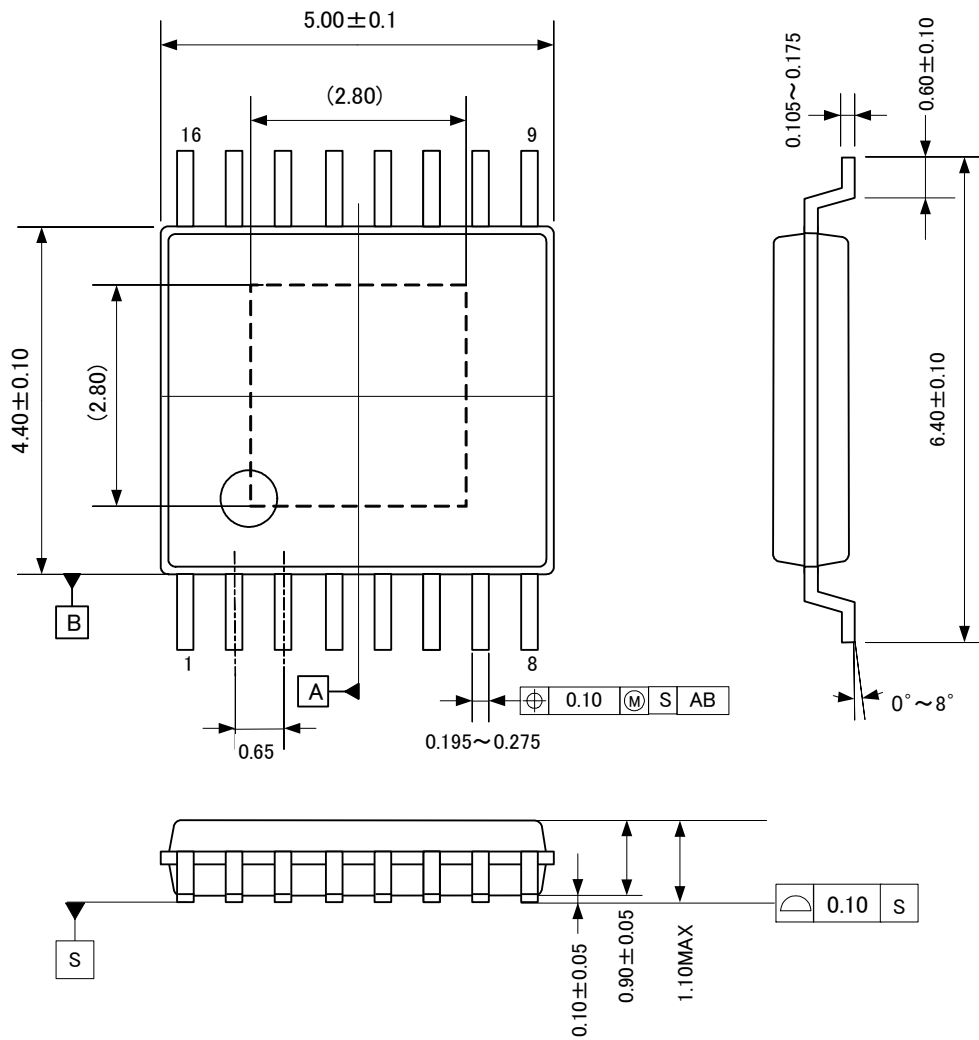

(Unit: mm)

Figure 10. Package Dimensions

IMPORTANT NOTICE

- These products and their specifications are subject to change without notice. When you consider any use or application of these products, please make inquiries the sales office of Asahi Kasei Microdevices Corporation (AKM) or authorized distributors as to current status of the products.
- Descriptions of external circuits, application circuits, software and other related information contained in this document are provided only to illustrate the operation and application examples of the semiconductor products. You are fully responsible for the incorporation of these external circuits, application circuits, software and other related information in the design of your equipments. AKM assumes no responsibility for any losses incurred by you or third parties arising from the use of these information herein. AKM assumes no liability for infringement of any patent, intellectual property, or other rights in the application or use of such information contained herein.
- Any export of these products, or devices or systems containing them, may require an export license or other official approval under the law and regulations of the country of export pertaining to customs and tariffs, currency exchange, or strategic materials.
- AKM products are neither intended nor authorized for use as critical components^{Note1)} in any safety, life support, or other hazard related device or system^{Note2)}, and AKM assumes no responsibility for such use, except for the use approved with the express written consent by Representative Director of AKM. As used here:
 - Note1) A critical component is one whose failure to function or perform may reasonably be expected to result, whether directly or indirectly, in the loss of the safety or effectiveness of the device or system containing it, and which must therefore meet very high standards of performance and reliability.
 - Note2) A hazard related device or system is one designed or intended for life support or maintenance of safety or for applications in medicine, aerospace, nuclear energy, or other fields, in which its failure to function or perform may reasonably be expected to result in loss of life or in significant injury or damage to person or property.
- It is the responsibility of the buyer or distributor of AKM products, who distributes, disposes of, or otherwise places the product with a third party, to notify such third party in advance of the above content and conditions, and the buyer or distributor agrees to assume any and all responsibility and liability for and hold AKM harmless from any and all claims arising from the use of said product in the absence of such notification.