

LH3 Torque & Multi-turn Position Sensor

SX-4472



Features:

- 5° sensor with torque, multi-turn position output, and flex circuit harness
- Ideally suited for demanding electric power steering systems

Electrical

Torque Signal Linearity	±3%
Torque Hysteresis	0.5% maximum
Torque Signal Microgradient	±30% of theoretical slope over 0.4° interval
Torque Sensed Angle	±5°
Position Signal Linearity (P1, P2)	±1.5%
Position Signal Microgradient (P1, P2)	±30% of theoretical slope over 2° interval
Multi-turn Position Accuracy (P3)	±3%
Multi-turn Position Sensed Angle	±720°
Total Resistance	438 Ω ±30%

Mechanical

Torque Mechanical Travel	±11.4°
Position Mechanical Travel	Continuous
Turning Torque (rotor to rotor)	0.03 NM maximum
Turning Torque (position rotor to housing)	0.06 NM maximum
Weight	grams maximum

Environmental

Operating Temperature Range	-40°C to +85°C
Shock	14 ms half-sine at 300 m/s ²
Vibration	10 to 55 Hz with 1 mm P-P constant displacement, 120 hours each of 3 planes
Torque Rotational Life	1 million cycles
Position Rotational Life	1 million cycles
Storage Temperature Range	-40°C to +105°C



General Note

TT Electronics reserves the right to make changes in product specification without notice or liability. All information is subject to TT Electronics' own data and is considered accurate at time of going to print.

TT Electronics | BI Technologies
4200 Bonita Place, Fullerton, CA 92835-1053, USA | Ph: +1 714 447 2300
www.ttelectronics.com | sensors@ttelectronics.com

Output Charts

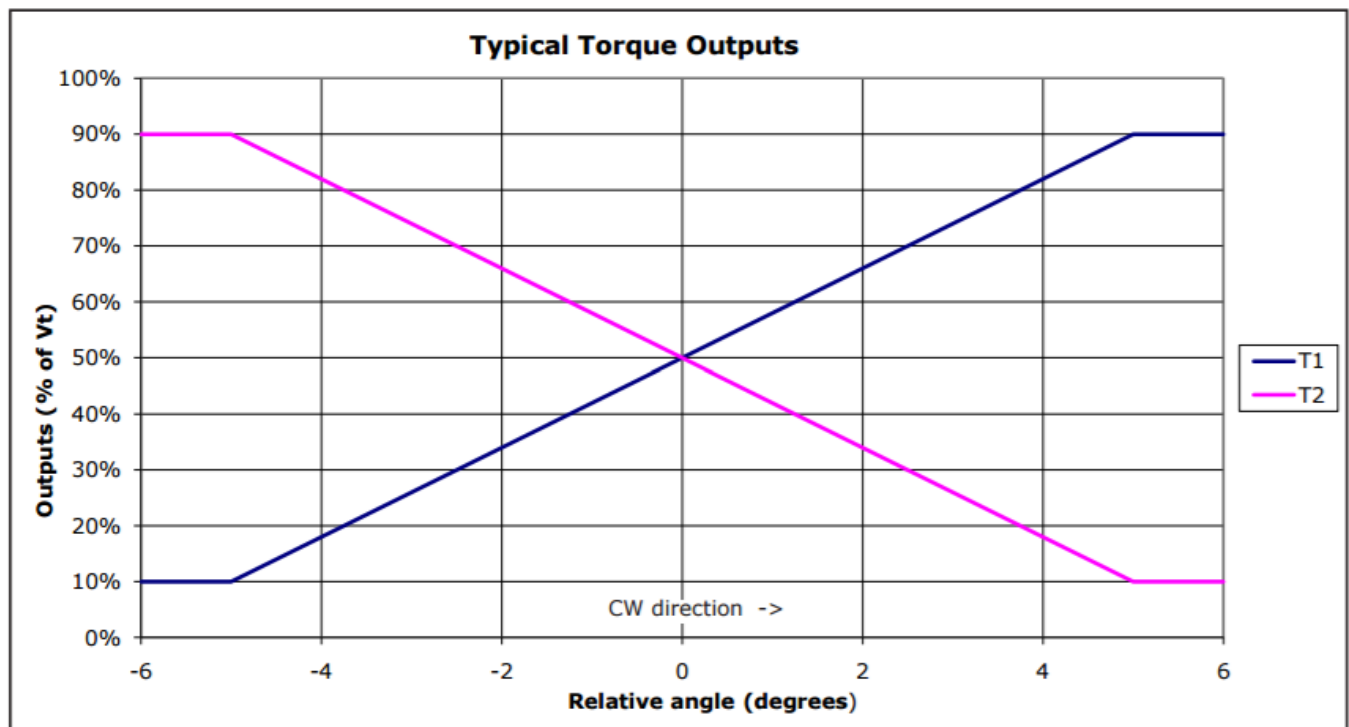
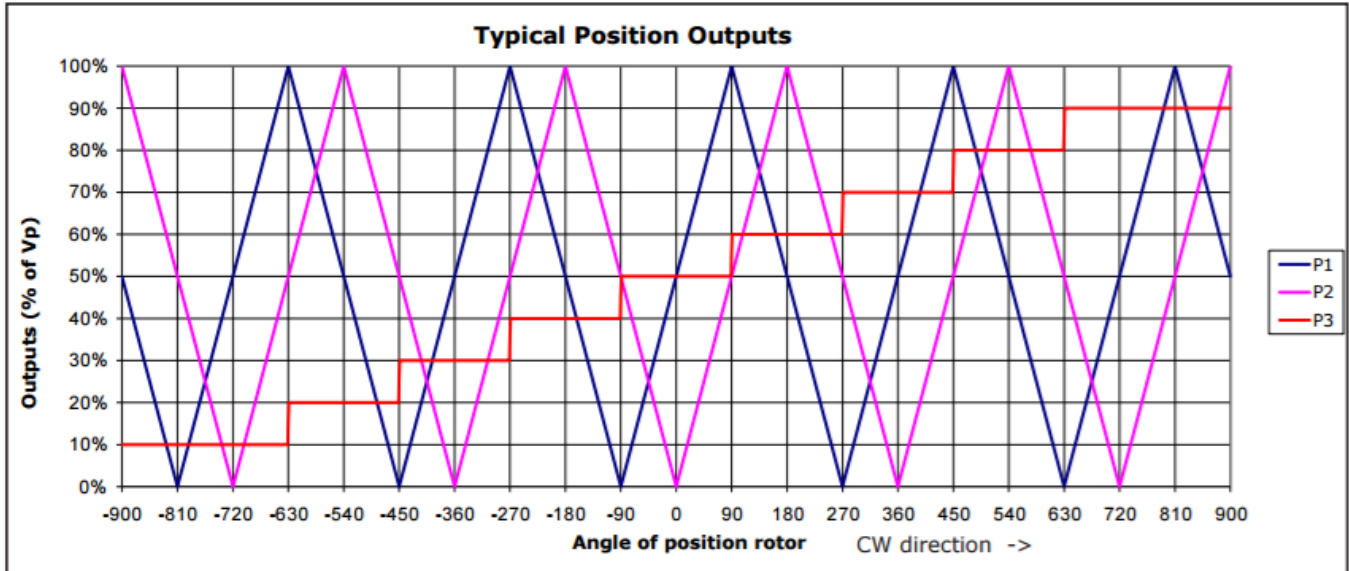

General Note

TT Electronics reserves the right to make changes in product specification without notice or liability. All information is subject to TT Electronics' own data and is considered accurate at time of going to print.

TT Electronics | BI Technologies
 4200 Bonita Place, Fullerton, CA 92835-1053, USA | Ph: +1 714 447 2300
www.ttelectronics.com | sensors@ttelectronics.com

LH3 Torque & Multi-turn Position Sensor



Outline Drawing

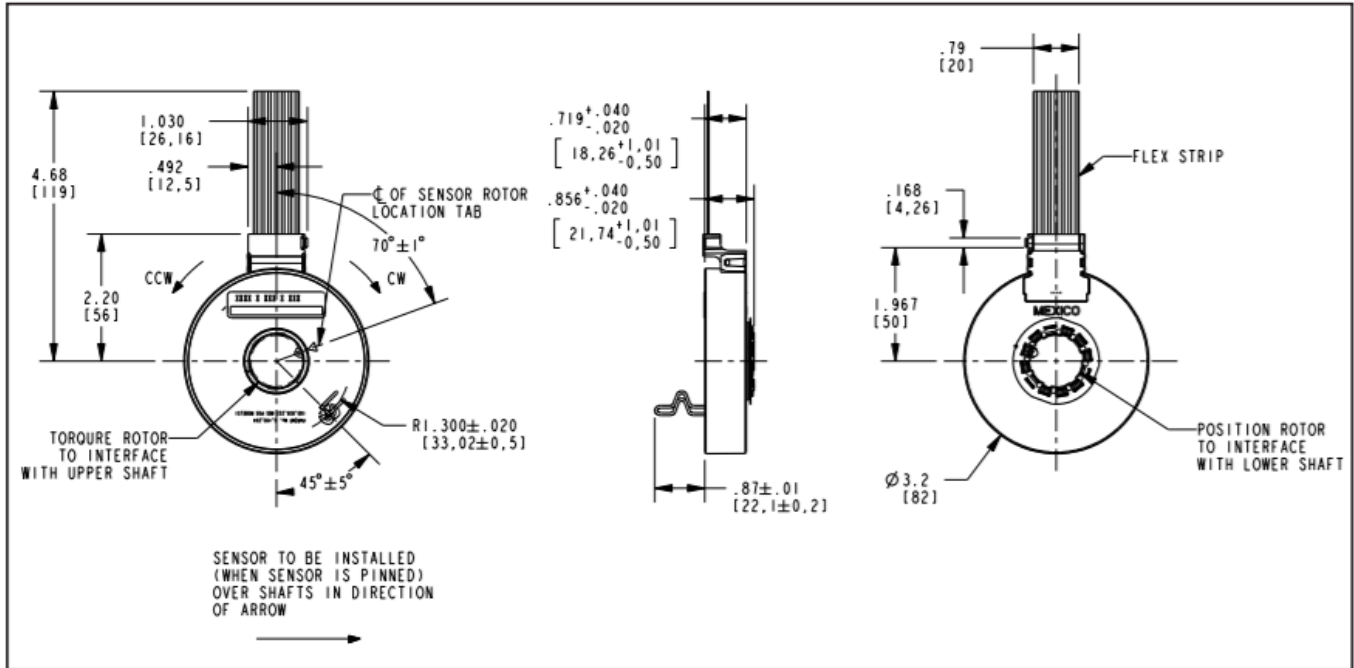

Tolerances ± 0.25 mm unless otherwise specified. See drawing # 122-4472-80 for details.

Barcode Label

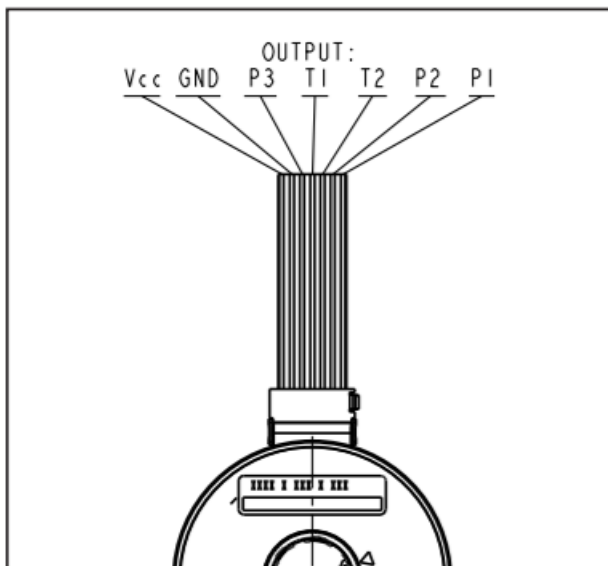

Barcode Label

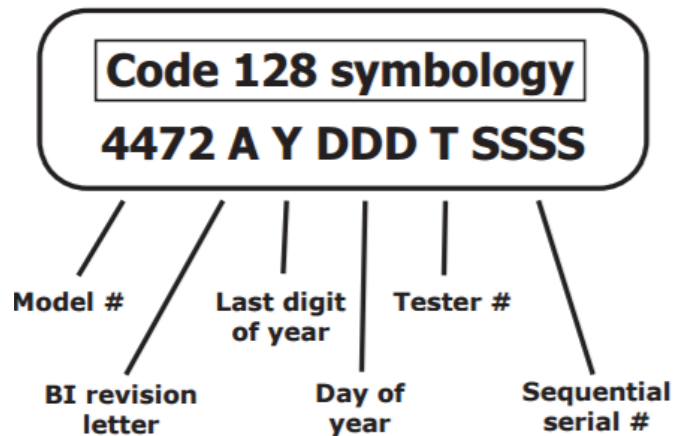

General Note

TT Electronics reserves the right to make changes in product specification without notice or liability. All information is subject to TT Electronics' own data and is considered accurate at time of going to print.

TT Electronics | BI Technologies
 4200 Bonita Place, Fullerton, CA 92835-1053, USA | Ph: +1 714 447 2300
www.ttelectronics.com | sensors@ttelectronics.com

Recommended Interface

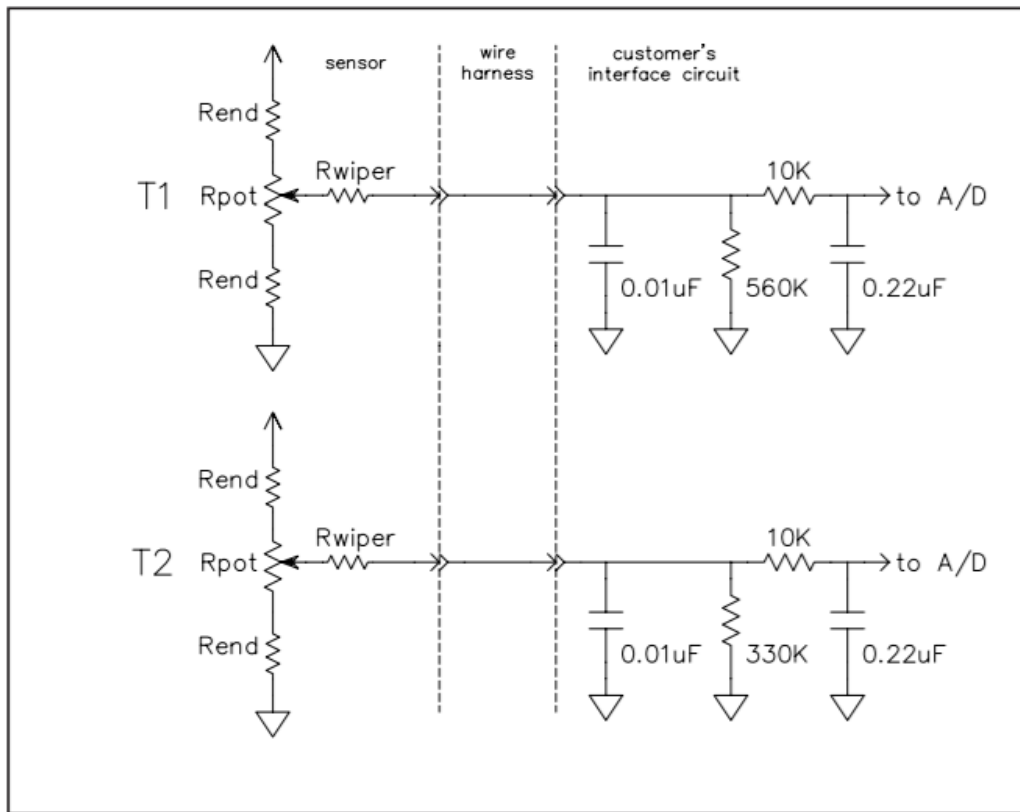
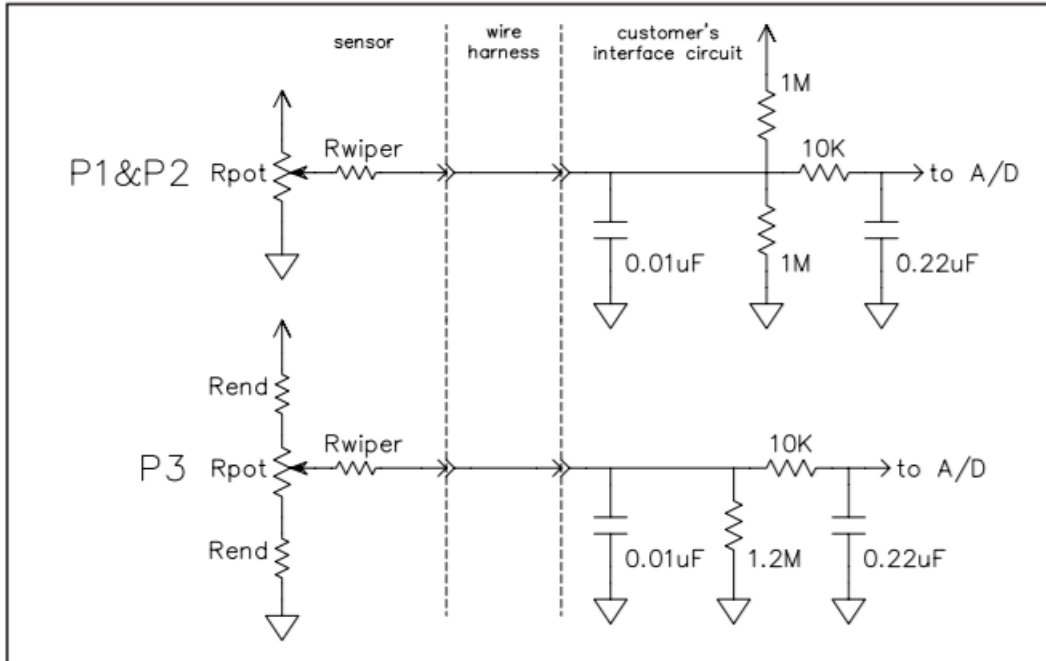

General Note

TT Electronics reserves the right to make changes in product specification without notice or liability. All information is subject to TT Electronics' own data and is considered accurate at time of going to print.

TT Electronics | BI Technologies
 4200 Bonita Place, Fullerton, CA 92835-1053, USA | Ph: +1 714 447 2300
www.ttelectronics.com | sensors@ttelectronics.com