

Tension-Clamp Ultra-Slim Signal Conditioners M6S Series

SIGNAL TRANSMITTER

Functions & Features

- Maintenance-free tension clamp connection
- 5.9-mm wide ultra-slim design
- Low profile allows the M6S module mounted in a 120-mm deep panel
- Galvanically isolates process instrumentation signals
- High-density mounting
- Power indicator LED

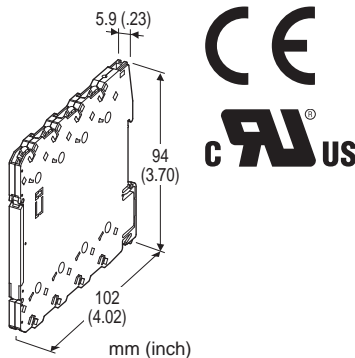

MODEL: M6SVS-[1][2]-[3][4]

ORDERING INFORMATION

- Code number: M6SVS-[1][2]-[3][4]
- Specify a code from below for each [1] through [4].
(e.g. M6SVS-4W4W-R/K/UL/Q)
- Special input and output ranges (For codes Z & 0)
- Specify the specification for option code /Q
(e.g. /C01)

[1] INPUT

Current

- A: 4 - 20 mA DC (Input resistance 50 Ω)
- B: 2 - 10 mA DC (Input resistance 100 Ω)
- C: 1 - 5 mA DC (Input resistance 200 Ω)
- D: 0 - 20 mA DC (Input resistance 50 Ω)
- E: 0 - 16 mA DC (Input resistance 50 Ω)
- F: 0 - 10 mA DC (Input resistance 100 Ω)
- G: 0 - 1 mA DC (Input resistance 1000 Ω)
- H: 10 - 50 mA DC (Input resistance 20 Ω)
- Z: Specify current (See INPUT SPECIFICATIONS)

Voltage

- 3: 0 - 1 V DC (Input resistance 1 M Ω min.)
- 4: 0 - 10 V DC (Input resistance 1 M Ω min.)
- 5: 0 - 5 V DC (Input resistance 1 M Ω min.)

- 6: 1 - 5 V DC (Input resistance 1 M Ω min.)
- 4W: -10 - +10 V DC (Input resistance 1 M Ω min.)
- 5W: -5 - +5 V DC (Input resistance 1 M Ω min.)
- 0: Specify voltage (See INPUT SPECIFICATIONS)

[2] OUTPUT

Current

- A: 4 - 20 mA DC (Load resistance 550 Ω max.)
- D: 0 - 20 mA DC (Load resistance 550 Ω max.)
- G: 0 - 1 mA DC (Load resistance 11 k Ω max.)
- Z: Specify current (See OUTPUT SPECIFICATIONS)

Voltage

- 3: 0 - 1 V DC (Load resistance 1000 Ω min.)
- 4: 0 - 10 V DC (Load resistance 10 k Ω min.)
- 5: 0 - 5 V DC (Load resistance 5000 Ω min.)
- 6: 1 - 5 V DC (Load resistance 5000 Ω min.)
- 4W: -10 - +10 V DC (Load resistance 20 k Ω min.)
- 5W: -5 - +5 V DC (Load resistance 10 k Ω min.)
- 0: Specify voltage (See OUTPUT SPECIFICATIONS)

[3] POWER INPUT

AC Power

- M2: 100 - 240 V AC (Operational voltage range 90 - 264 V, 47 - 66 Hz)
- (UL not available)

DC Power

- R: 24 V DC
- (Operational voltage range 24 V \pm 10 %, ripple 10 %p-p max.)

[4] OPTIONS (multiple selections)

Response Time (0 - 90 %)

- blank: Standard (\leq 0.5 sec.)
- /K: Fast Response (Approx. 3.5 msec. voltage output; Approx. 25 msec. current output)

Standards & Approvals

- blank: CE marking
- /UL: UL approval, CE marking

Other Options

- blank: none
- /Q: Option other than the above (specify the specification)

SPECIFICATIONS OF OPTION: Q

COATING (For the detail, refer to M-System's web site.)

- /C01: Silicone coating
- /C02: Polyurethane coating

GENERAL SPECIFICATIONS

Connection

Input and output: Tension clamp

Power input: Via the Installation Base (model: M6SBS)

(not available for AC power input)

or Tension clamp

Applicable wire size: 0.2 to 2.5 mm², stripped length 8 mm

Housing material: Flame-resistant resin (black)

Isolation: Input to output to power

Zero adjustment: -2 to +2 % (front)

(Output code 4W, 5W: Adjustable at 0V. No output below 0 mA for the code D.)

Span adjustment: 98 to 102 % (front)

Power LED: Green light turns on when the power is supplied.

INPUT SPECIFICATIONS

■ **DC Current:** Input resistor incorporated

Specify input resistance value among followings for code Z.

20Ω, 50Ω, 100Ω, 200Ω, 249Ω, 1000Ω

($0.125 \text{ W} \geq [\text{Input current}]^2 \times R$)

■ **DC Voltage:** -30 - +30 V DC

Minimum span: 100 mV

Offset: Max. 1.5 times span

Input resistance: 1 MΩ min. (10 kΩ min. with no power supplied)

OUTPUT SPECIFICATIONS

■ **DC Current:** 0 - 20 mA DC

Minimum span: 1 mA

Offset: Max. 1.5 times span

Load resistance: Output drive 11 V max.

■ **DC Voltage:** 0 - 10 V DC

Minimum span: 1 V

Offset: Max. 1.5 times span

Load resistance: Output drive 1 mA max.; at $\geq 1 \text{ V}$

INSTALLATION

Power Consumption

•AC: Max. 2 VA

•DC: Approx. 0.5 W

Operating temperature: -20 to +55°C (-4 to +131°F)

Operating humidity: 30 to 90 %RH (non-condensing)

Mounting: Installation Base (model: M6SBS) or DIN rail

Weight: 60 g (2.1 oz)

PERFORMANCE in percentage of span

Accuracy: $\pm 0.1 \%$

Temp. coefficient: $\pm 0.01 \%/^{\circ}\text{C}$ ($\pm 0.006 \%/^{\circ}\text{F}$)

Line voltage effect: $\pm 0.1 \%$ over voltage range

Insulation resistance: $\geq 100 \text{ M}\Omega$ with 500 V DC

Dielectric strength: 2000 V AC @1 minute (input to output to power to ground)

STANDARDS & APPROVALS

EU conformity:

EMC Directive

EMI EN 61000-6-4

EMS EN 61000-6-2

Low Voltage Directive

EN 61010-1

Installation Category II

Pollution Degree 2

Input or output to power: Reinforced insulation (300 V)

Input to output: Basic insulation (300 V)

RoHS Directive

EN 50581

Approval:

UL/C-UL nonincendive Class I, Division 2,

Groups A, B, C, and D

(ANSI/ISA-12.12.01, CAN/CSA-C22.2 No.213)

UL/C-UL general safety requirements

(UL 61010-1, CAN/CSA-C22.2 No.61010-1)

EXTERNAL VIEW

(With the cover open)

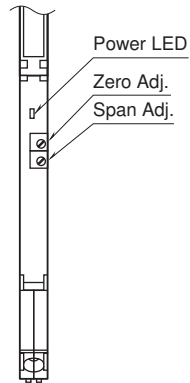

EXTERNAL DIMENSIONS & TERMINAL ASSIGNMENTS unit: mm (inch)

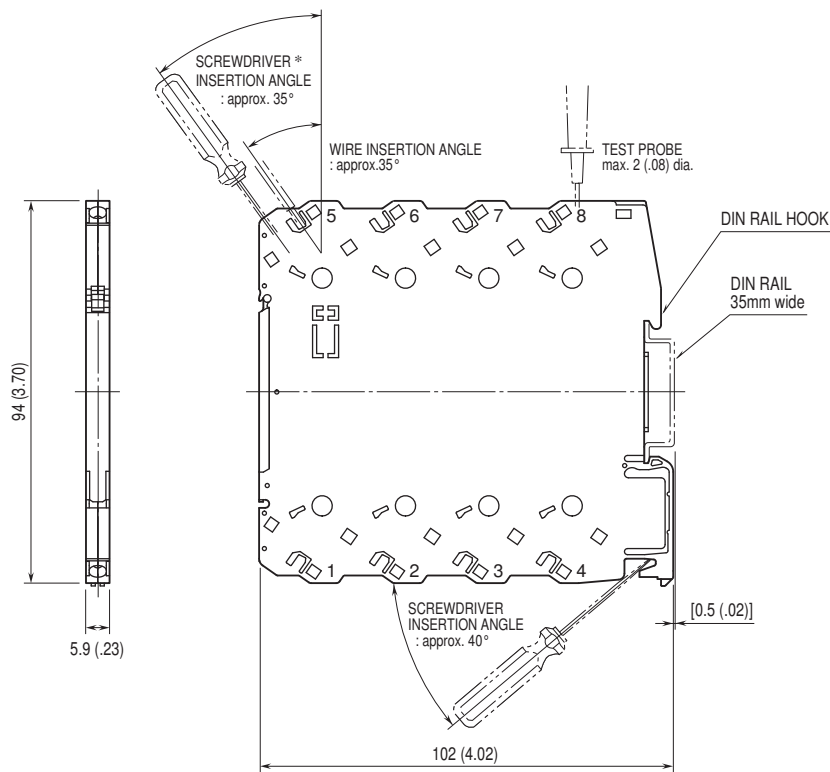

• When mounting, no extra space is needed between units.

*Use a minus screwdriver: tip width 3.8 mm max., tip thickness 0.5 to 0.6 mm

SCHEMATIC CIRCUITRY & CONNECTION DIAGRAM

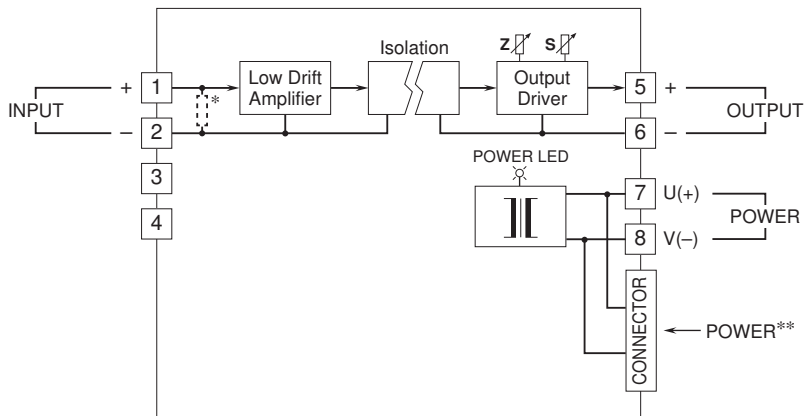

* Input shunt resistor incorporated for current input.
 ** Available only for DC power input type



Specifications are subject to change without notice.