

Verpackt im Gurt nach DIN IEC 60286-3
 Tape on Reel Packaging according to DIN IEC 60286-3
 Verpackungseinheit: 280 Stück
 Packaging unit: 280 pcs

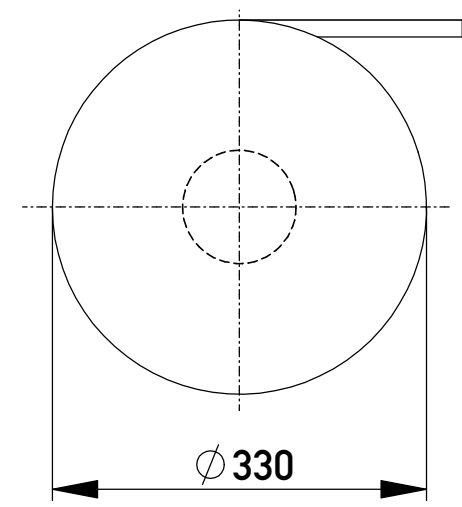

Abspulrichtung - Reel off Direction

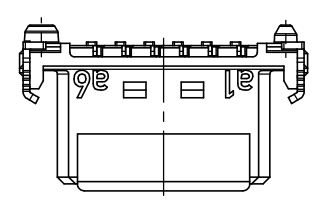
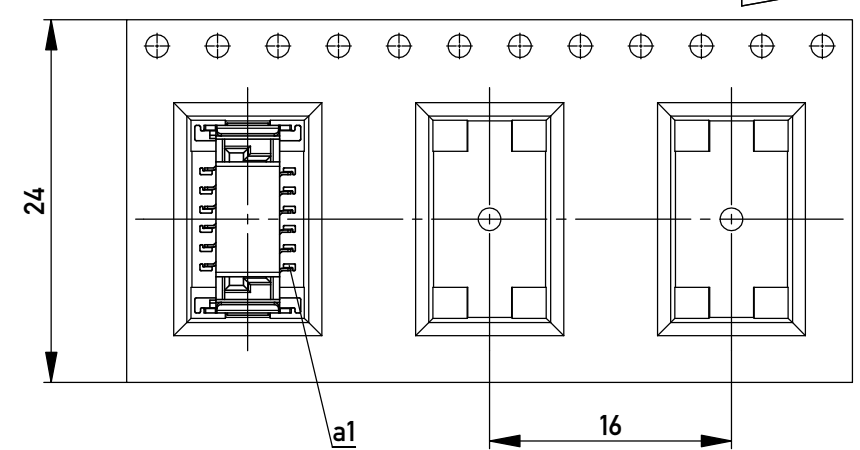

Leiterplatten-Layout Vorschlag für SMT
 PCB-Layout Proposal for SMT

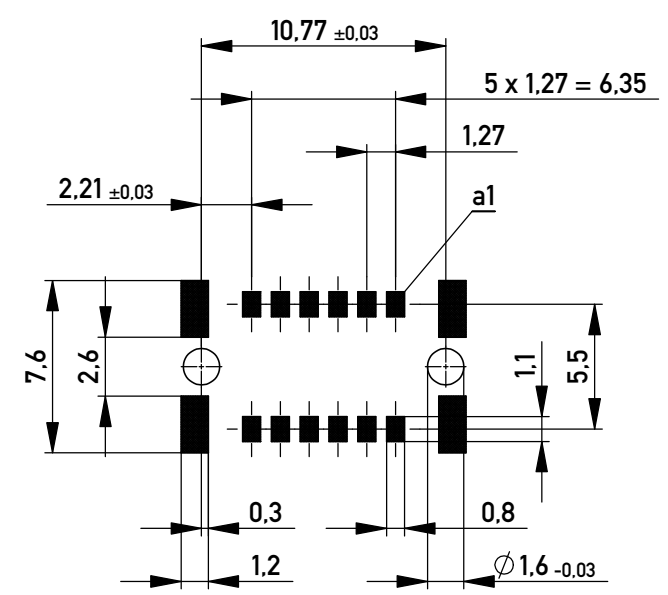

Anforderungsstufe 1
 Performance Level 1

Kontaktbereich vergoldet
 Mating Area gold plating

Anschlussbereich verzinkt 4-6 µm
 Terminal Area 4-6 µm tin plating

Koplanarität der Anschlüsse ≤ 0,1 mm
 Coplanarity Area of Termination ≤ 0,1 mm

BA 7-13 - 8mm Bauhöhe

type7-13 - low profile

Information:		Tolerances		Scale 3:1	BA 7-13 - 8mm Bauhöhe	
All rights reserved. Only for Information. To ensure that this is the latest version of this drawing, please contact one of the ERNI companies before using.		Subject to modification without prior notice. Drawing will not be updated.		Designation		K
www.ERNI.com		www.ERNI.com		Federl. SMC-B 12-SMD-BA7-13 Female SMC-B 12-SMD-type7-13		
d	03.11.2015	www.ERNI.com		100103880002		A3
Index	Date	www.ERNI.com		Class SMCB		

Copyright by ERNI GmbH
 Proprietary notice pursuant to ISO 16016 to be observed.