

## Plug-in Signal Conditioners K-UNIT

### DC/FREQUENCY CONVERTER

(field-configurable)

#### Functions & Features

- Providing a pulse rate output in proportion to DC input signal
- Frequency range adjustable with a front-mounted 16-position rotary switch and potentiometer
- Low-end cutout adjustable
- Isolation up to 2000 V AC
- High-density mounting

#### Typical Applications

- Totalizing applications in combination with a counter

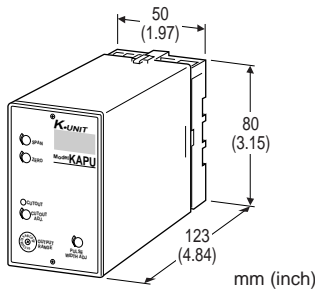

## MODEL: KAPU-[1][2]-[3][4]

### ORDERING INFORMATION

- Code number: KAPU-[1][2]-[3][4]
- Specify a code from below for each of [1] through [4].  
(e.g. KAPU-61-B/Q)
- Special input range (For codes Z & 0)
  - Output frequency range (e.g. 0 - 500 Hz)
  - Specify the specification for option code /Q  
(e.g. /C01/S01)

### [1] INPUT

#### Current

- A: 4 - 20 mA DC (Input resistance 250 Ω)
- A1: 4 - 20 mA DC (Input resistance 50 Ω)
- B: 2 - 10 mA DC (Input resistance 500 Ω)
- C: 1 - 5 mA DC (Input resistance 1000 Ω)
- D: 0 - 20 mA DC (Input resistance 50 Ω)
- E: 0 - 16 mA DC (Input resistance 62.5 Ω)
- F: 0 - 10 mA DC (Input resistance 100 Ω)
- G: 0 - 1 mA DC (Input resistance 1000 Ω)
- H: 10 - 50 mA DC (Input resistance 100 Ω)
- Z: Specify current (See INPUT SPECIFICATIONS)

#### Voltage

- 1: 0 - 10 mV DC (Input resistance 10 kΩ min.)

- 15: 0 - 50 mV DC (Input resistance 10 kΩ min.)
- 16: 0 - 60 mV DC (Input resistance 10 kΩ min.)
- 2: 0 - 100 mV DC (Input resistance 100 kΩ min.)
- 3: 0 - 1 V DC (Input resistance 1 MΩ min.)
- 4: 0 - 10 V DC (Input resistance 1 MΩ min.)
- 5: 0 - 5 V DC (Input resistance 1 MΩ min.)
- 6: 1 - 5 V DC (Input resistance 1 MΩ min.)
- 4W: -10 - +10 V DC (Input resistance 1 MΩ min.)
- 0: Specify voltage (See INPUT SPECIFICATIONS)

### [2] OUTPUT

- 1: Open collector (max. frequency 10 kHz)
- 2: 5 V pulse (max. frequency 10 kHz)
- 3: Relay contact (max. 130 pulses/min.)
- 4: Low frequency open collector (max. 130 pulses/min.)
- 5: Low frequency 5 V pulse (max. 130 pulses/min.)
- 6: 24 V pulse (max. 130 pulses/min.)
- 7: Middle range frequency open collector (max. 312 Hz)
- 8: Middle range frequency 5 V voltage pulse (max. 312 Hz)

### [3] POWER INPUT

#### AC Power

- B: 100 V AC
- C: 110 V AC
- D: 115 V AC
- F: 120 V AC
- G: 200 V AC
- H: 220 V AC
- J: 240 V AC

#### DC Power

- S: 12 V DC
- R: 24 V DC

### [4] OPTIONS

- blank: none
- /Q: With options (specify the specification)

### SPECIFICATIONS OF OPTION: Q (multiple selections)

#### COATING (For the detail, refer to M-System's web site.)

- /C01: Silicone coating
- /C02: Polyurethane coating
- /C03: Rubber coating

#### TERMINAL SCREW MATERIAL

- /S01: Stainless steel

### GENERAL SPECIFICATIONS

- Construction: Plug-in
- Connection: M3.5 screw terminals
- Screw terminal: Chromated steel (standard) or stainless steel

**Housing material:** Flame-resistant resin (black)  
**Isolation:** Input to output to power  
**Zero adjustment:** 0 - 5 % (front)  
**Span adjustment:** 50 - 100 % of range (front)  
**Output frequency adjustment:** Preselecting range with a rotary switch and fine control with span adjustment (50 - 100 %)  
**Output pulse width adjustment:** Three-turn screwdriver adjustment (front)  
**Low-end cutout:** 0 to 10 % (front); a red LED assists in adjusting the cutout point; turns on during the cutout.

## INPUT SPECIFICATIONS

■ **DC Current:**  
 Shunt resistor attached to the input terminals (0.5 W)  
 Specify input resistance value for code Z.  
 ■ **DC Voltage:** -300 - +300 V DC  
**Minimum span:** 10 mV  
**Offset:** Max. 1.5 times span  
**Input resistance**  
 Span 10 - 100 mV :  $\geq 10 \text{ k}\Omega$   
 Span 0.1 - 1 V :  $\geq 100 \text{ k}\Omega$   
 Span  $\geq 1 \text{ V}$  :  $\geq 1 \text{ M}\Omega$

## OUTPUT SPECIFICATIONS

**Note:** For factory setting, maximum frequency of the selected range is used to determine pulse width. Pulse width is adjusted until the duty ratio becomes 50 % of the maximum frequency. If this value lies outside of the adjustable range, either maximum or minimum selectable value will be used.

■ **Open Collector:**  
 50 V DC @ 50 mA (resistive load)  
**Frequency range:** 0 - 10 kHz  
**ON pulse width:** 40  $\mu$ sec. - 0.8 msec. adjustable  
**Saturation voltage:** 0.6 V DC  
 ■ **Low Frequency Open Collector:**  
 50 V DC @ 50 mA (resistive load)  
**Frequency range:** 0 - 130 pulses/min.  
**ON pulse width:** 40 msec. - 0.8 sec. adjustable  
**Saturation voltage:** 0.6 V DC  
 ■ **Middle Range Frequency Open Collector:**  
 50 V DC @ 50 mA (resistive load)  
**Frequency range:** 0 - 312 Hz  
**ON pulse width:** 2 - 35 msec. adjustable  
**Saturation voltage:** 0.6 V DC  
 ■ **Relay Contact:** 120 V AC @ 200 mA ( $\cos \phi = 1$ )  
 240 V AC @ 100 mA ( $\cos \phi = 1$ )  
 24 V DC @ 200 mA (resistive load)  
**Maximum switching voltage:** 380 V AC or 125V DC  
**Maximum switching power:** 24 VA or 4.8 W

**Minimum load:** 5 V DC @ 10 mA  
**Frequency range:** 0 - 130 pulses/min.  
**ON pulse width:** 40 msec. - 0.8 sec. adjustable  
**Relay life:**  
 $\geq 5 \times 10^7$  cycles (mechanical)  
 $\geq 10^5$  cycles (electrical)  
 ■ **5 V Pulse**  
**Frequency range:** 0 - 10 kHz  
**Low pulse width:** 40  $\mu$ sec. - 0.8 msec. adjustable  
**High level:** 5 V  $\pm 10$  %  
**Low level:**  $\leq 0.5 \text{ V}$   
**Load resistance:** 600  $\Omega$  min.  
 ■ **Middle Range Frequency 5 V Pulse**  
**Frequency range:** 0 - 312 Hz  
**Low pulse width:** 2 - 35 msec. adjustable  
**High level:** 5 V  $\pm 10$  %  
**Low level:**  $\leq 0.5 \text{ V}$   
**Load resistance:** 600  $\Omega$  min.  
 ■ **Low Frequency 5 V Pulse**  
**Frequency range:** 0 - 130 pulses/min.  
**Low pulse width:** 40 msec. - 0.8 sec. adjustable  
**High level:** 5 V  $\pm 10$  %  
**Low level:**  $\leq 0.5 \text{ V}$   
**Load resistance:** 600  $\Omega$  min.  
 ■ **24 V Pulse**  
**Frequency range:** 0 - 130 pulses/min.  
**High pulse width:** 40 msec. - 0.8 sec. adjustable  
**High level:** 24 V  $\pm 10$  %  
**Low level:**  $\leq 0.5 \text{ V}$   
**Load current:** 30 mA max.  
**Load resistance:** 800  $\Omega$  min.

### • Open Collector, 5V Pulse

SW No.	SPAN RANGE	
	MIN. (50%)	MAX. (100%)
0	0 - 5 kHz	0 - 10 kHz
1	0 - 2.5 kHz	0 - 5 kHz
2	0 - 1.25 kHz	0 - 2.5 kHz
3	0 - 625 Hz	0 - 1.25 kHz
4	0 - 312 Hz	0 - 625 Hz
5	0 - 156 Hz	0 - 312 Hz
6	0 - 78 Hz	0 - 156 Hz
7	0 - 39 Hz	0 - 78 Hz
8	0 - 20 Hz	0 - 39 Hz
9	0 - 10 Hz	0 - 20 Hz
A	0 - 5 Hz	0 - 10 Hz
B	0 - 2.5 Hz	0 - 5 Hz
C	0 - 1.25 Hz	0 - 2.5 Hz
D	0 - 36 pulses/min.	0 - 1.25 Hz
E	0 - 18 pulses/min.	0 - 36 pulses/min.
F	0 - 9 pulses/min.	0 - 18 pulses/min.

• Middle Range Frequency Open Collector & 5V Pulse

SW No.	SPAN RANGE	
	MIN. (50%)	MAX. (100%)
0	Not Used	Not Used
1	Not Used	Not Used
2	Not Used	Not Used
3	Not Used	Not Used
4	Not Used	Not Used
5	0 – 156 Hz	0 – 312 Hz
6	0 – 78 Hz	0 – 156 Hz
7	0 – 39 Hz	0 – 78 Hz
8	0 – 20 Hz	0 – 39 Hz
9	0 – 10 Hz	0 – 20 Hz
A	0 – 5 Hz	0 – 10 Hz
B	0 – 2.5 Hz	0 – 5 Hz
C	0 – 1.25 Hz	0 – 2.5 Hz
D	0 – 36 pulses/min.	0 – 1.25 Hz
E	0 – 18 pulses/min.	0 – 36 pulses/min.
F	0 – 9 pulses/min.	0 – 18 pulses/min.

Line voltage effect:  $\pm 0.1$  % over voltage range

Insulation resistance:  $\geq 100$  M $\Omega$  with 500 V DC

Dielectric strength: 2000 V AC @1 minute (input to output to power to ground)

• Relay Contact, Low-Freq. Open Collector & 5V Pulse, 24V Pulse

SW No.	SPAN RANGE	
	MIN. (50%)	MAX. (100%)
0	0 – 65 pulses/min.	0 – 130 pulses/min.
1	0 – 32 pulses/min.	0 – 65 pulses/min.
2	0 – 16 pulses/min.	0 – 32 pulses/min.
3	0 – 8 pulses/min.	0 – 16 pulses/min.
4	0 – 4 pulses/min.	0 – 8 pulses/min.
5	0 – 2 pulses/min.	0 – 4 pulses/min.
6	0 – 1 pulses/min.	0 – 2 pulses/min.
7	0 – 0.5 pulses/min.	0 – 1 pulses/min.
8	0 – 0.25 pulses/min.	0 – 0.5 pulses/min.
9	0 – 8 pulses/hour	0 – 0.25 pulses/min.
A	0 – 4 pulses/hour	0 – 8 pulses/hour
B	0 – 2 pulses/hour	0 – 4 pulses/hour
C	0 – 1 pulses/hour	0 – 2 pulses/hour
D	0 – 0.5 pulses/hour	0 – 1 pulses/hour
E	0 – 0.24 pulses/hour	0 – 0.5 pulses/hour
F	0 – 0.12 pulses/hour	0 – 0.24 pulses/hour

## INSTALLATION

### Power input

• **AC:** Operational voltage range: rating  $\pm 10$  %, 50/60  $\pm 2$  Hz, approx. 2 VA

• **DC:** operational voltage range: rating  $\pm 10$  % (ripple 10 %p-p max.)

approx. 2 W (70 mA at 24 V)

**Operating temperature:** -5 to +55°C (23 to 131°F)

**Operating humidity:** 30 to 90 %RH (non-condensing)

**Mounting:** Surface or DIN rail

**Weight:** 350 g (0.77 lb)

## PERFORMANCE in percentage of span

**Accuracy:**  $\pm 0.25$  %

**Temp. coefficient:**  $\pm 0.05$  %/°C ( $\pm 0.03$  %/°F)

## EXTERNAL VIEW

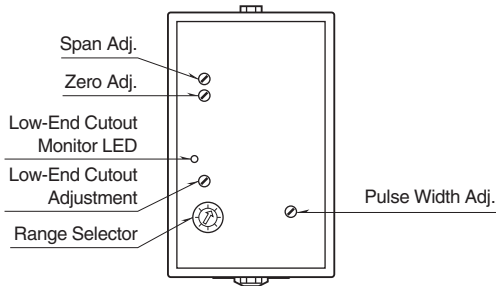

## EXTERNAL DIMENSIONS unit: mm (inch)

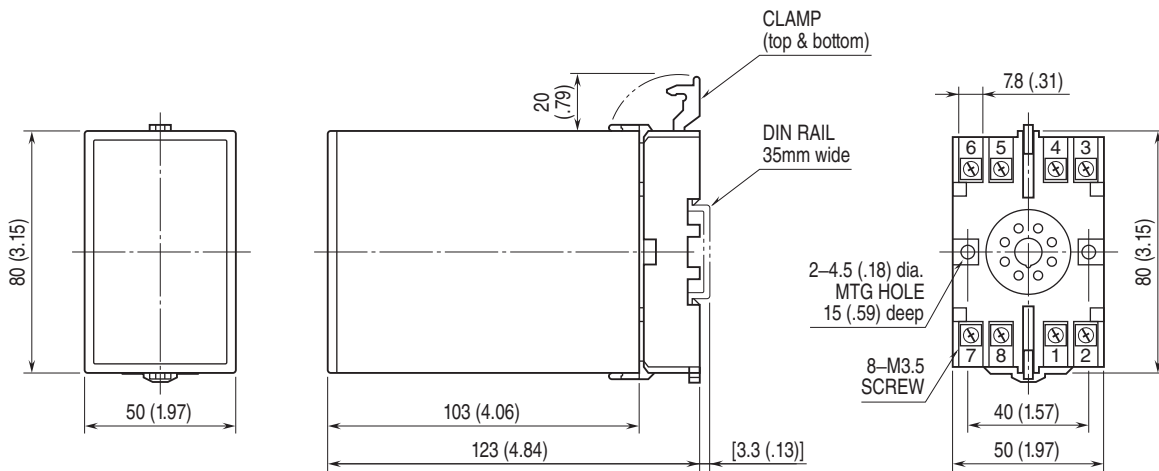

• When mounting, no extra space is needed between units.

## TERMINAL ASSIGNMENTS unit: mm (inch)

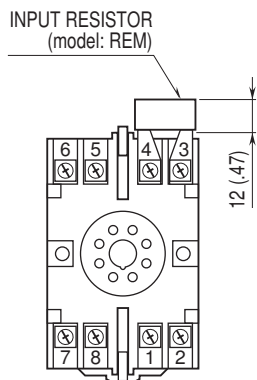

Input shunt resistor attached for current input.

## SCHEMATIC CIRCUITRY & CONNECTION DIAGRAM

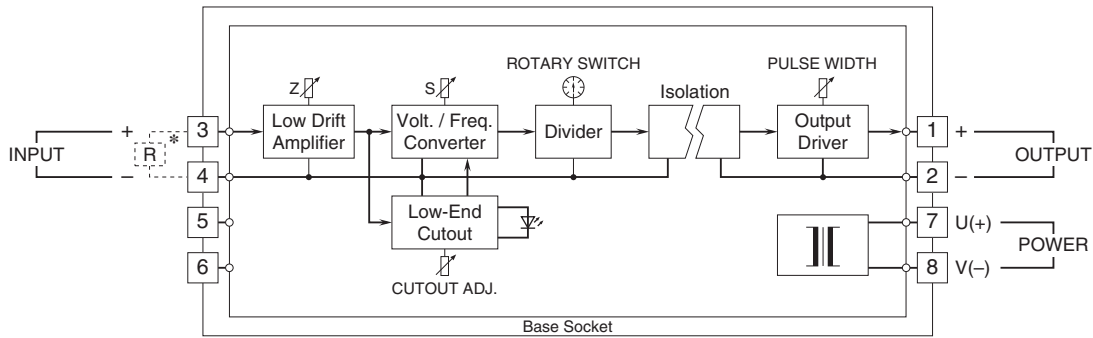

\*Input shunt resistor attached for current input.

Output Connection Examples

■ Open Collector

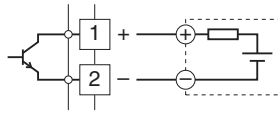

■ Voltage Pulse

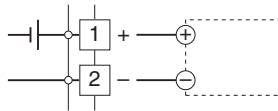

■ Relay

•AC Powered

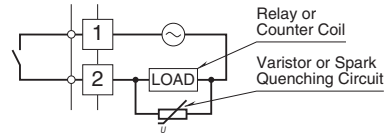

•DC Powered

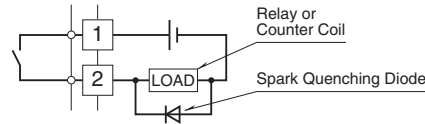

Specifications are subject to change without notice.