

### Guidelines for soldering MEMS microphones

By Alessandro Morcelli

#### Introduction

This application note provides guidelines and recommendations for soldering MEMS microphones on application boards. Microphones, as pressure sensors, sense the mechanical stress coming from the PCB, hence this force should be kept to a minimum. Printing and stencil parameters, followed by device footprints, recommended land and stencil patterns, and process considerations are presented in this document.

The following guidelines have been developed for the MEMS microphone family (MP45DT02, MP34DB01, MP34DT01, MP33AB01, and MP33AB01H) offered by STMicroelectronics.

Demonstration boards (STEVAL-MKI129Vx) for the evaluation and promotion of the MP45DT02, MP34DT01, and MP34DT01 are also available. Please refer to AN4184 "Microphone coupon boards STEVAL-MKI129Vx based on the MP45DT02, MP34DB01, and MP34DT01" on [www.st.com](http://www.st.com) for further information.

Figure 1. Mechanical specifications for soldering

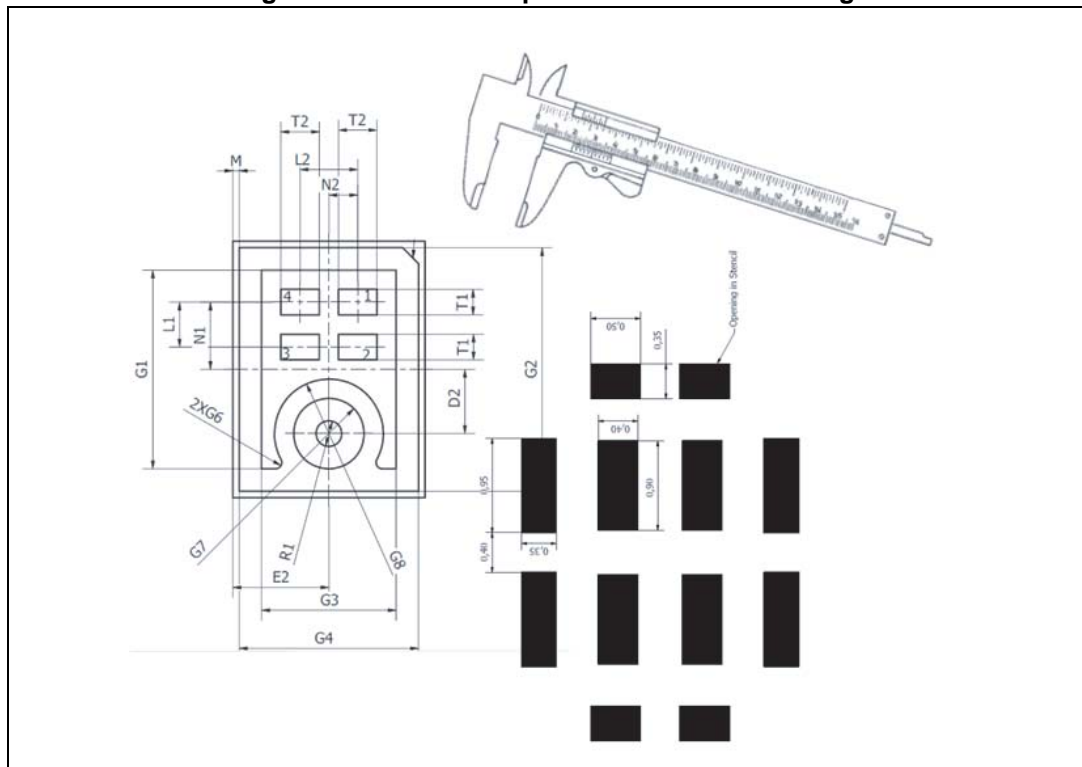

# Contents

- 1        Printing and stencil parameters ..... 3**
  
- 2        Device footprint, land pattern and stencil openings ..... 4**
  - 2.1    MP45DT02 and MP45DT02-M dimensions ..... 4
  - 2.2    MP34DB01 and MP34DB02 dimensions ..... 5
  - 2.3    MP34DT01 and MP34DT01-M dimensions ..... 7
  - 2.4    MP33AB01 and MP33AB01H dimensions ..... 8
  - 2.5    MP34DB02 dimensions ..... 9
  - 2.6    MP23AB02 dimension ..... 10
  
- 3        Process considerations ..... 11**
  
- 4        Revision history ..... 12**

# 1 Printing and stencil parameters

The soldering paste thickness and pattern are important for the proper microphone soldering process. Here below, some recommendations to be followed are listed:

- Stainless steel stencils are recommended
- Stencil thickness of 75 - 100  $\mu\text{m}$  (2.95 - 3.94 mils) is recommended for screen printing
- The final soldering paste thickness should allow proper cleaning of flux residuals and clearance between the sensor package and PCB
- Stencil aperture should have a rectangular shape
- The openings of the stencil for the signal pads should be between 70 - 90 % of the PCB pad
- Optionally, for better solder paste release, the aperture walls should be trapezoidal and the corners rounded
- The fine IC leads pitch requires accurate alignment of the stencil to the PCB. The stencil and printed circuit assembly should be aligned to within 25  $\mu\text{m}$  (1 mil) prior to application of the solder paste

## 2 Device footprint, land pattern and stencil openings

### 2.1 MP45DT02 and MP45DT02-M dimensions

Figure 2. MP45DT02 - device footprint and PCB land pattern

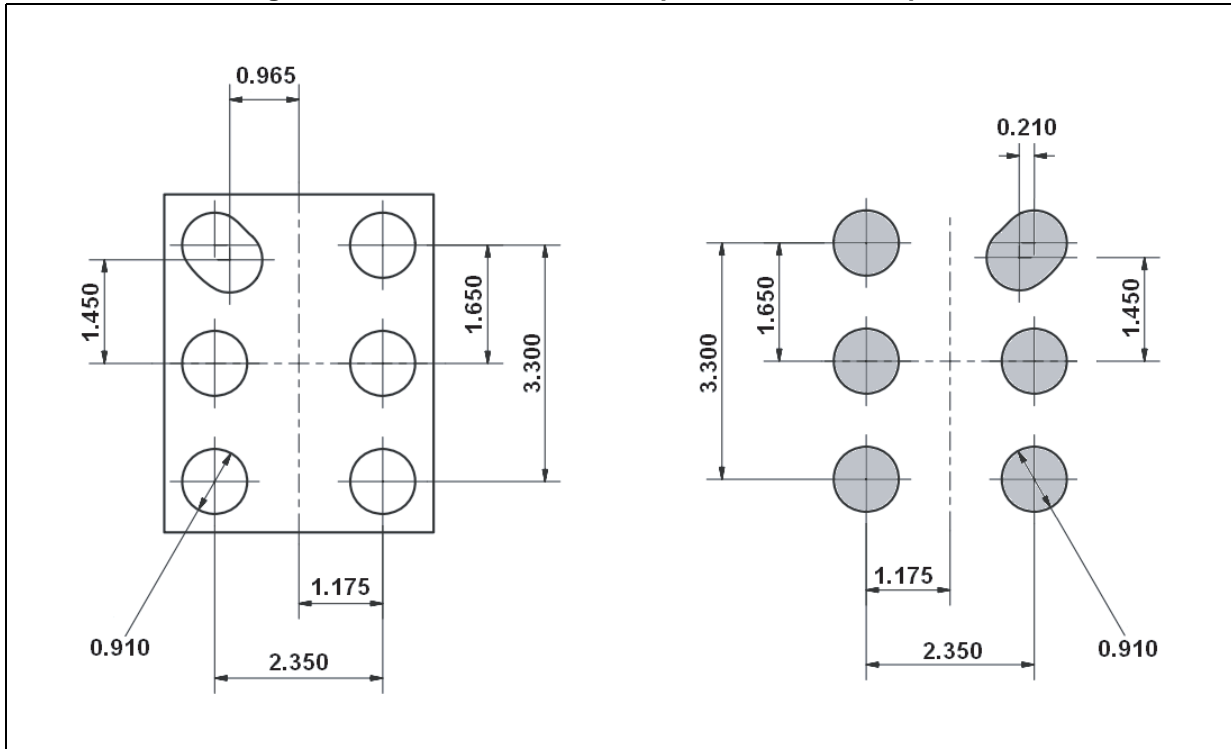
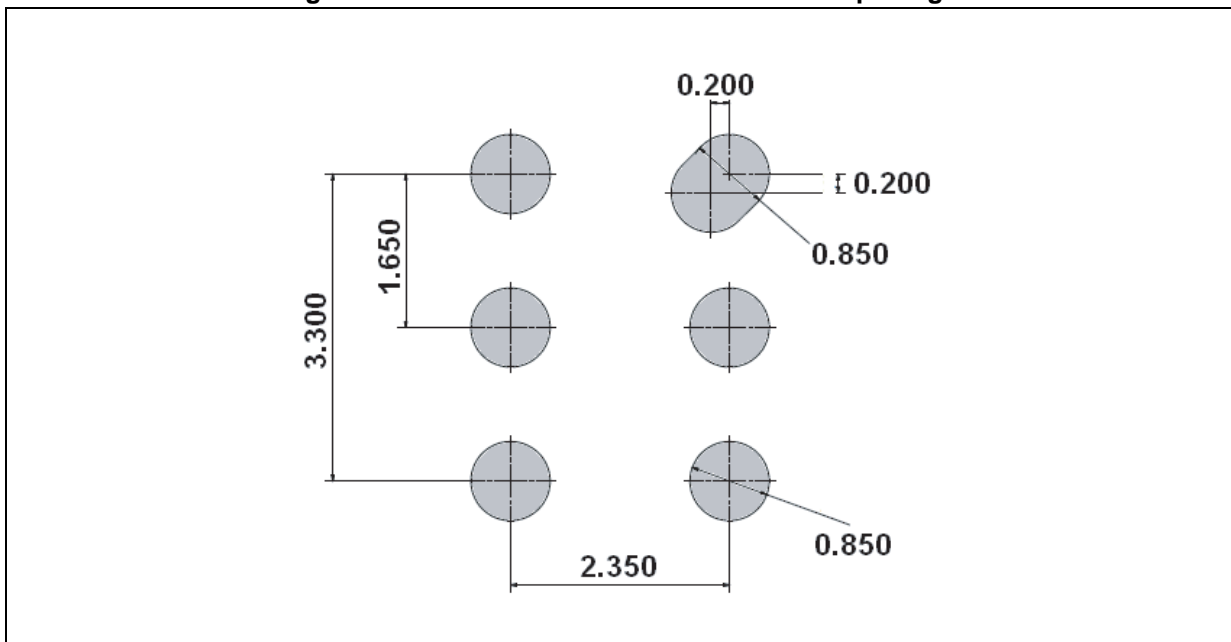

Figure 3. MP45DT02 - recommended stencil openings



## 2.2 MP34DB01 and MP34DB02 dimensions

Figure 4. MP34DB01 - device footprint and PCB land pattern

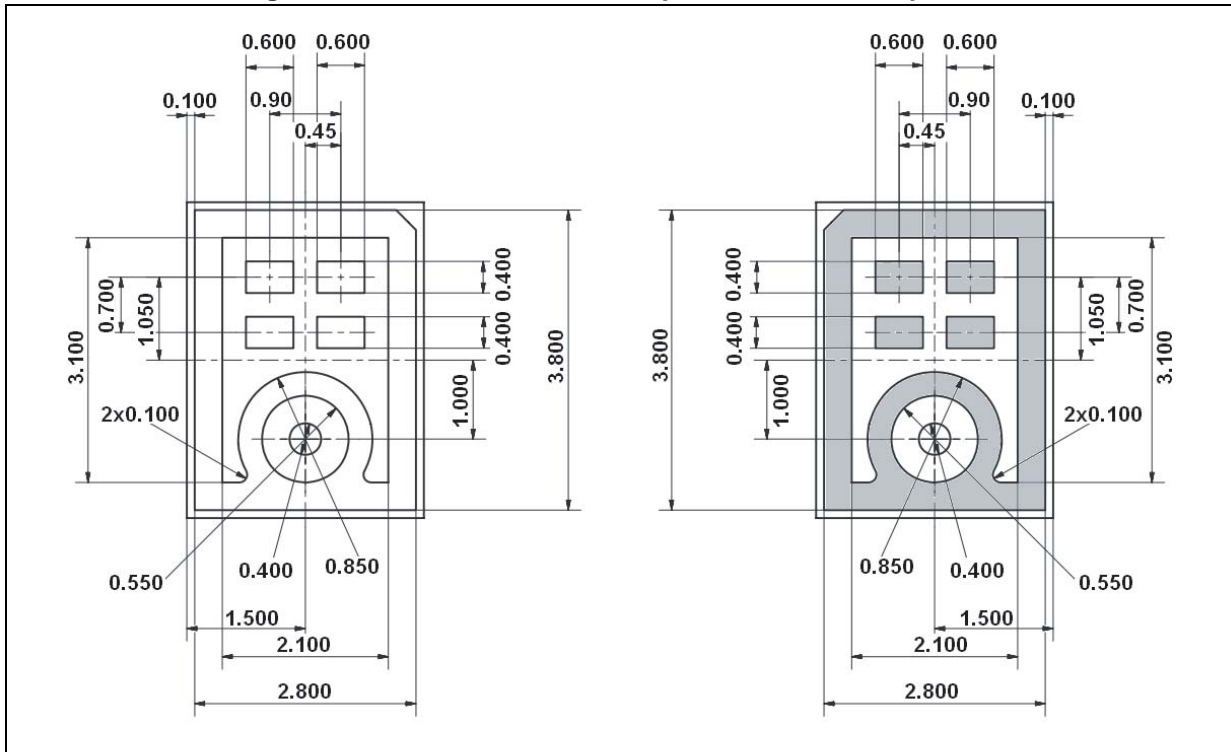

Figure 5. MP34DB01 - recommended stencil openings

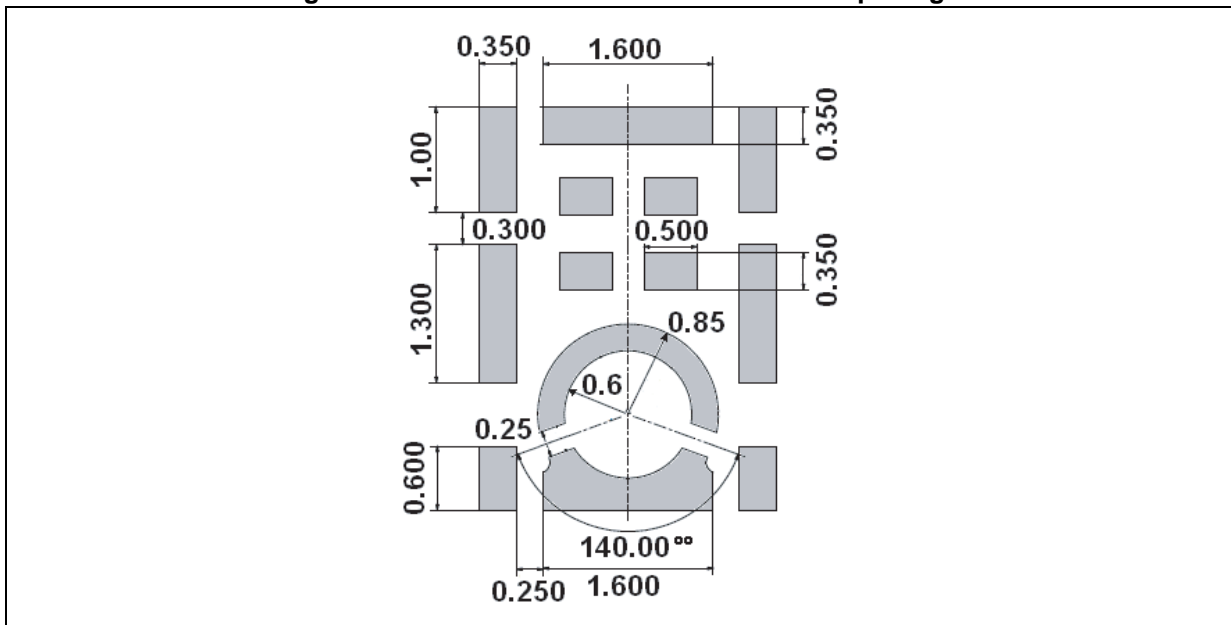

Figure 6. MP34DB02 - device footprint and PCB land pattern

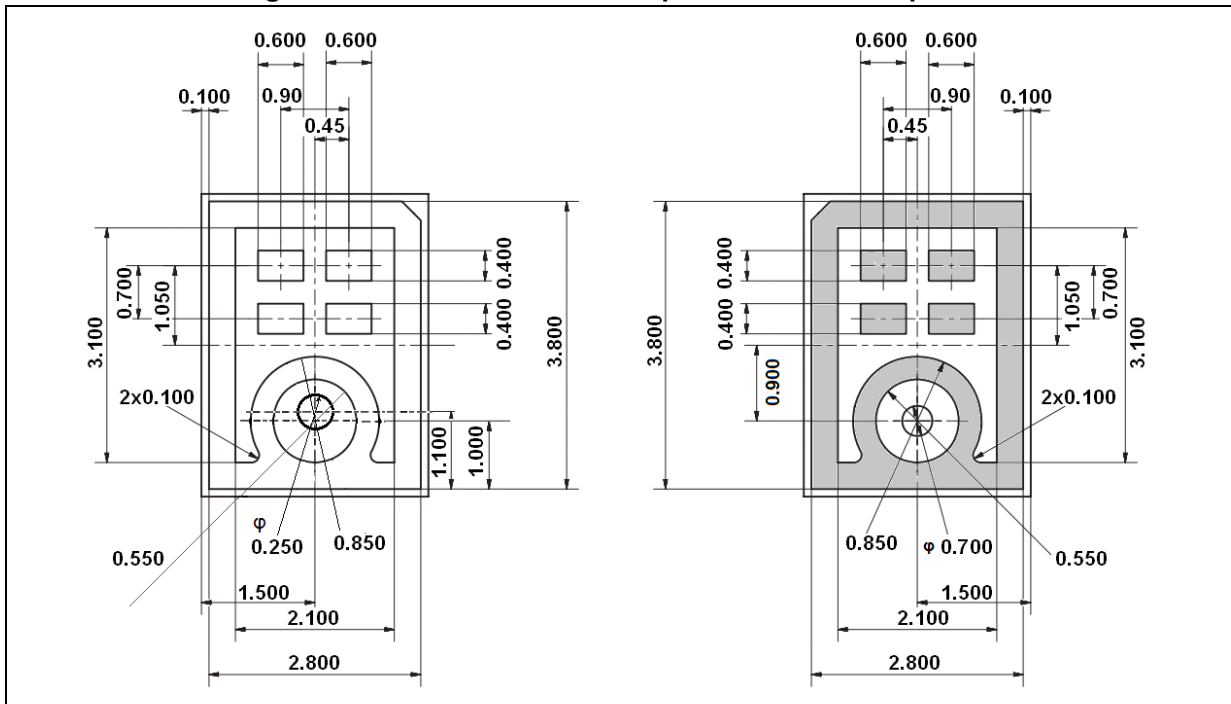
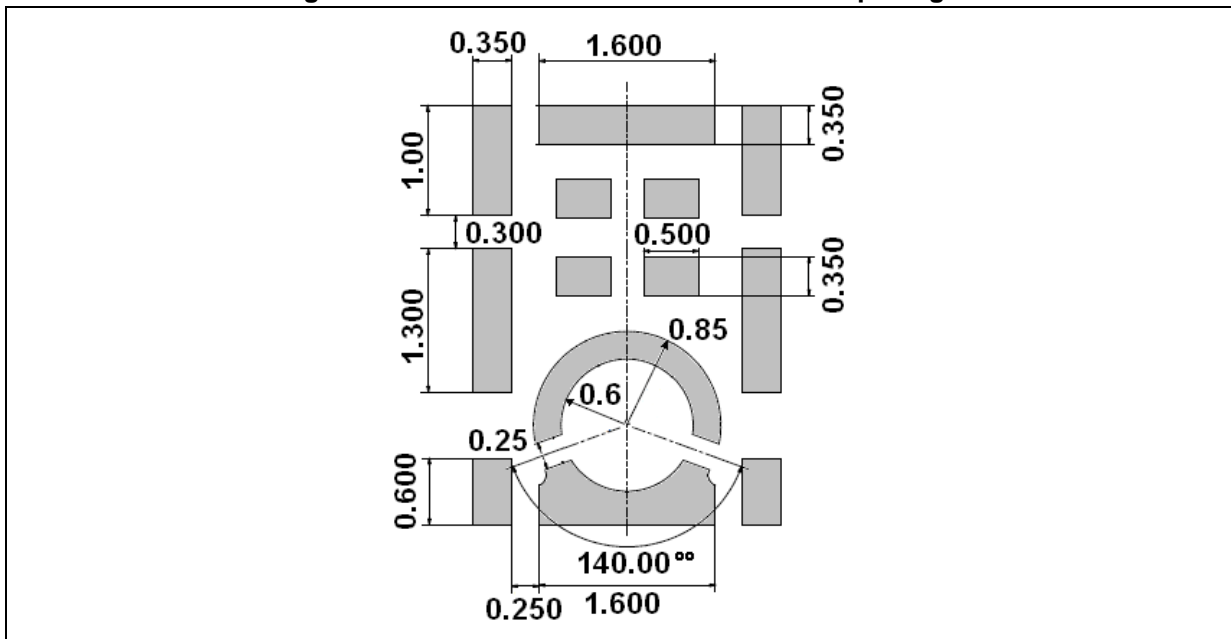

Figure 7. MP34DB02 - recommended stencil openings



Note: The hole position is slightly different for the MP34DB02, please refer to the datasheet for reference.

### 2.3 MP34DT01 and MP34DT01-M dimensions

Figure 8. MP34DT01 - device footprint and PCB land pattern

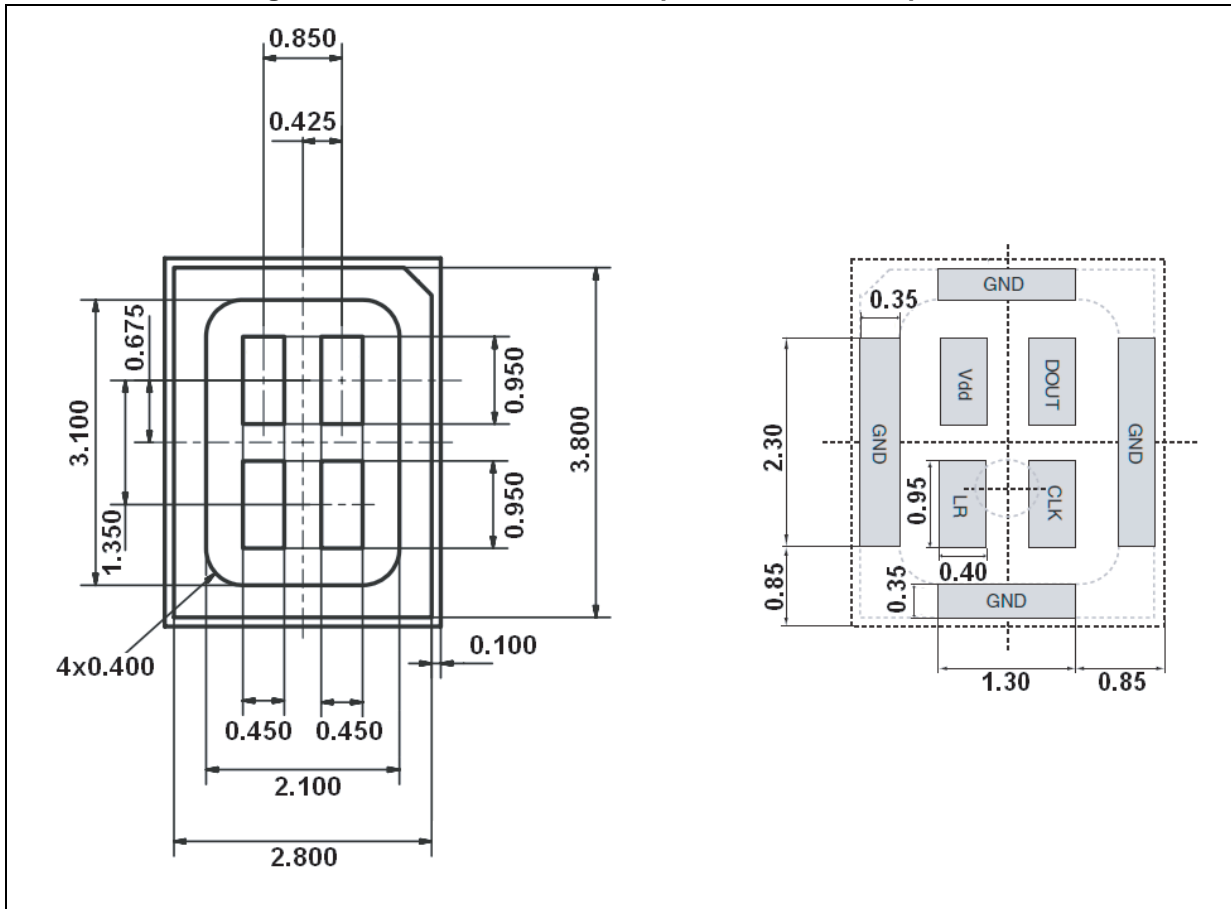
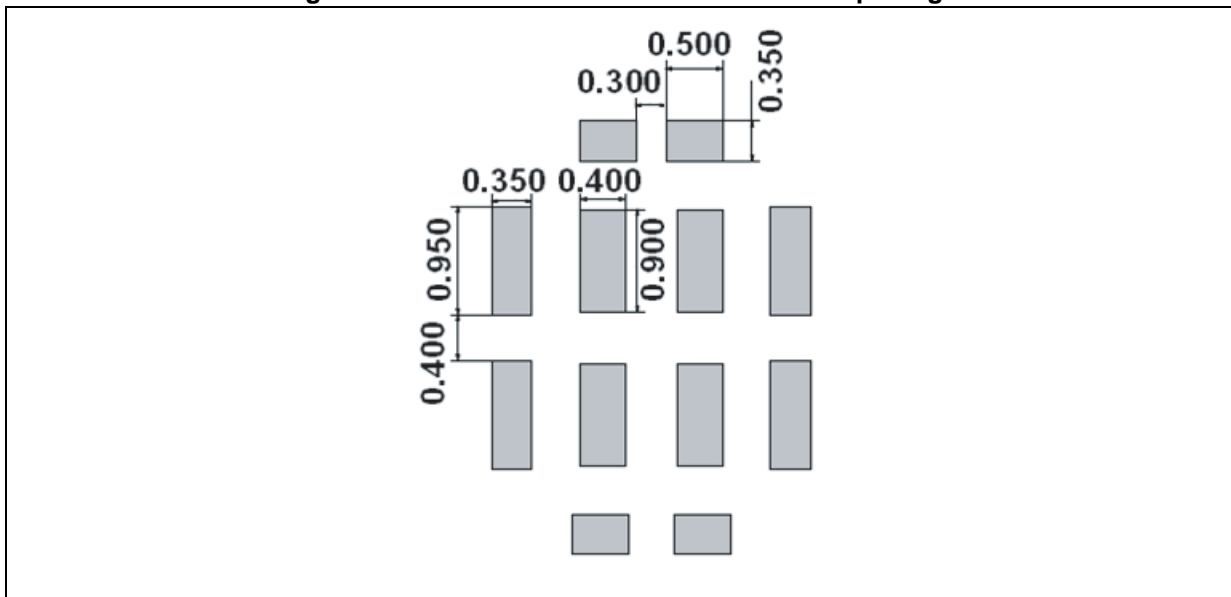

Figure 9. MP34DT01 - recommended stencil openings



## 2.4 MP33AB01 and MP33AB01H dimensions

Figure 10. MP33AB01 and MP33AB01H - device footprint and PCB land pattern

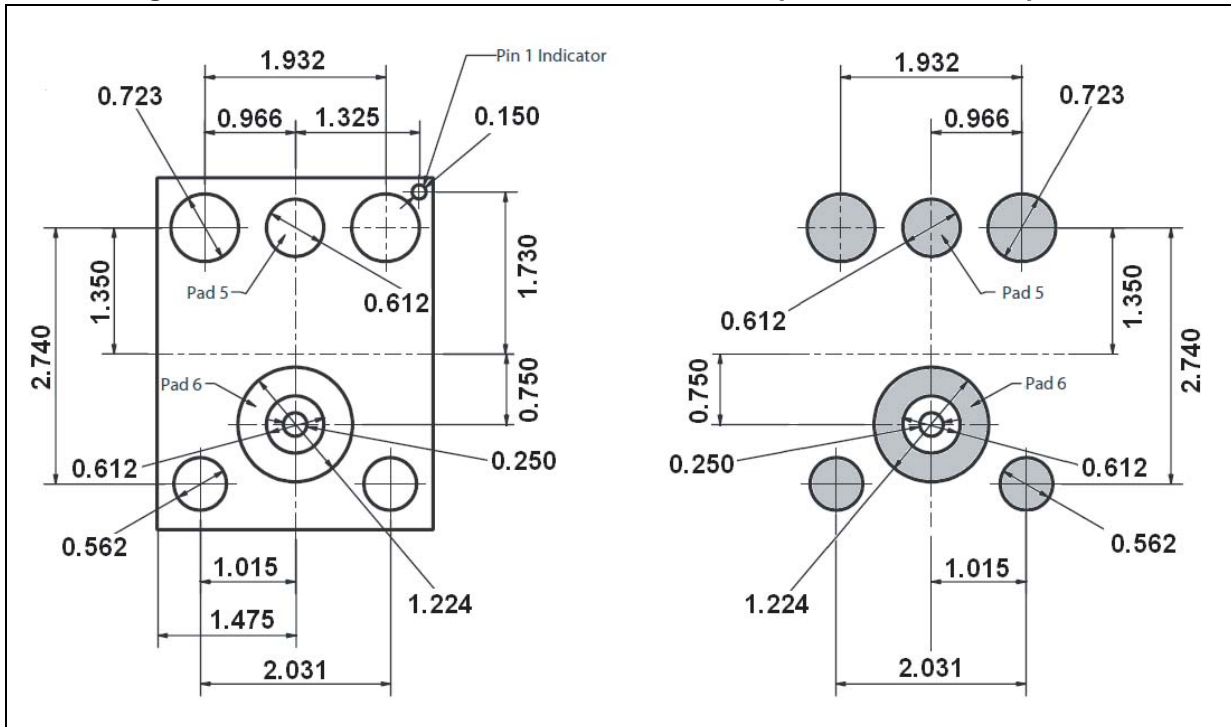
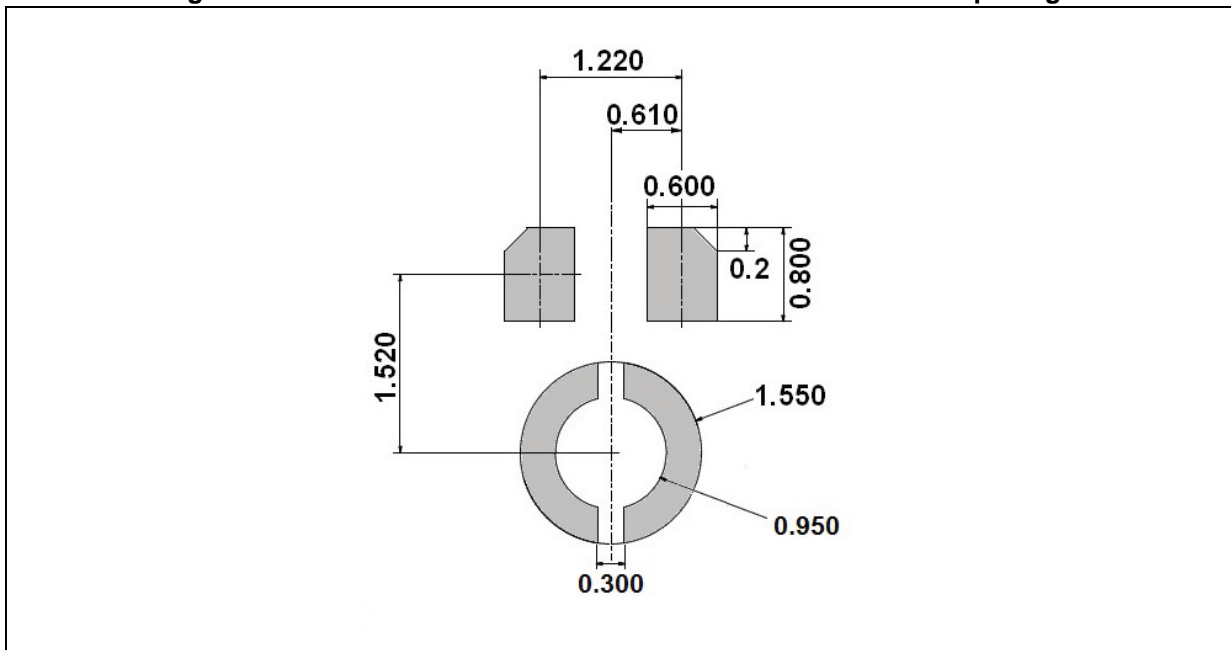

Figure 11. MP33AB01 and MP33AB01H - recommended stencil openings



## 2.5 MP34DB02 dimensions

Figure 12. MP34DB02 - device footprint

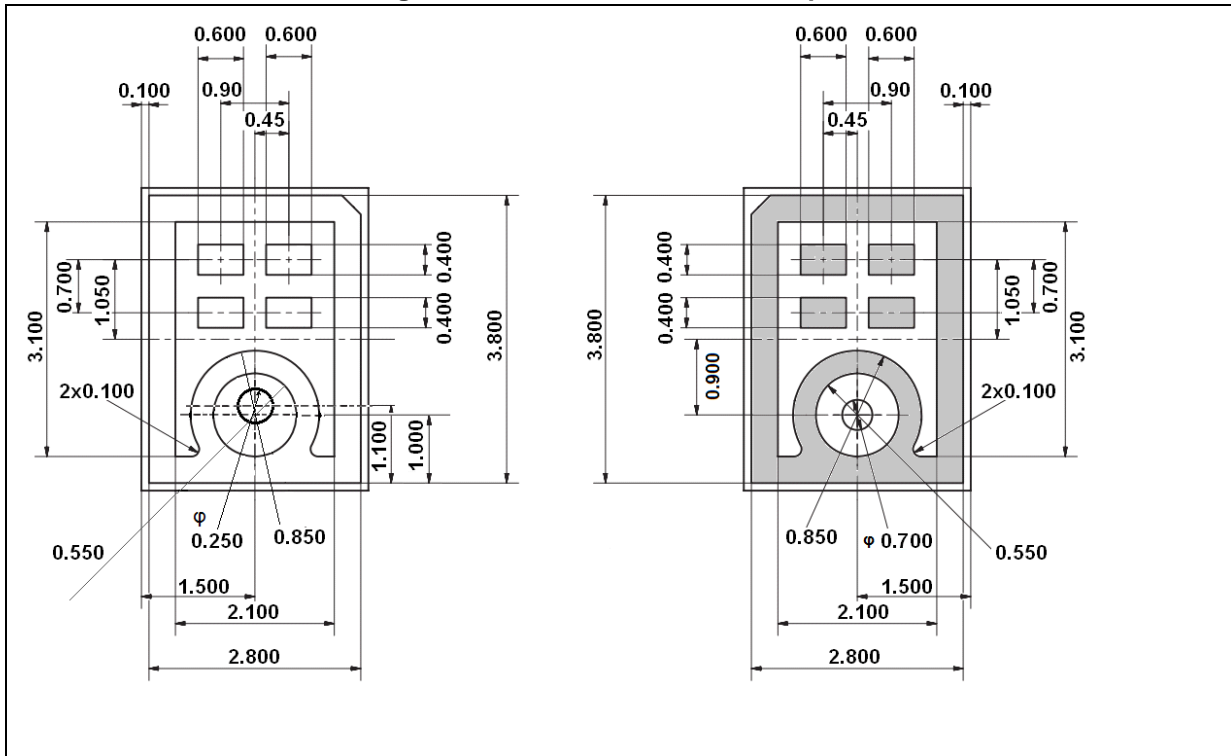
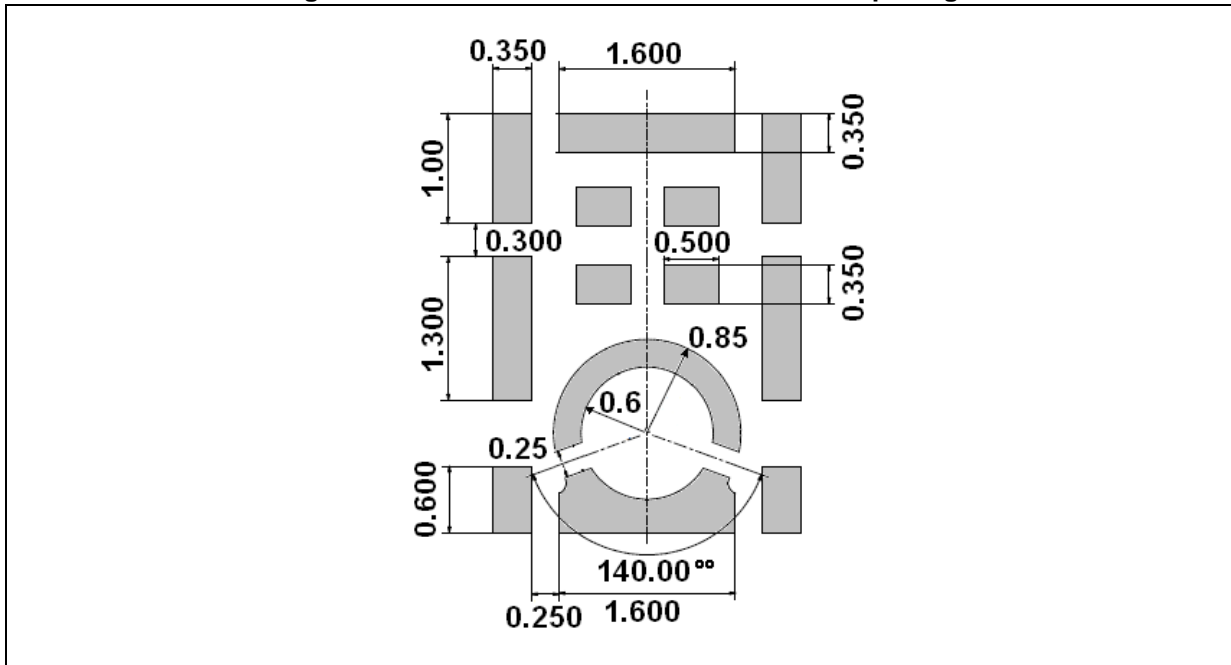

Figure 13. MP34DB02 - recommended stencil opening



## 2.6 MP23AB02 dimension

Figure 14. MP23AB02 - device footprint

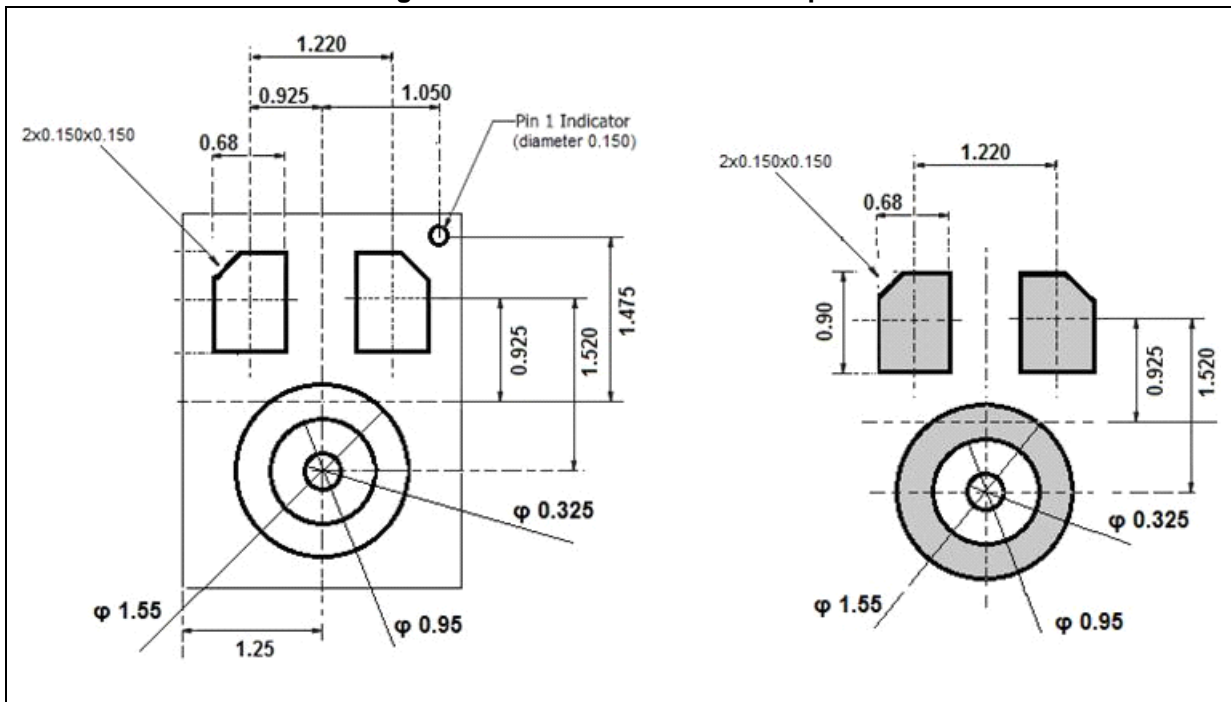
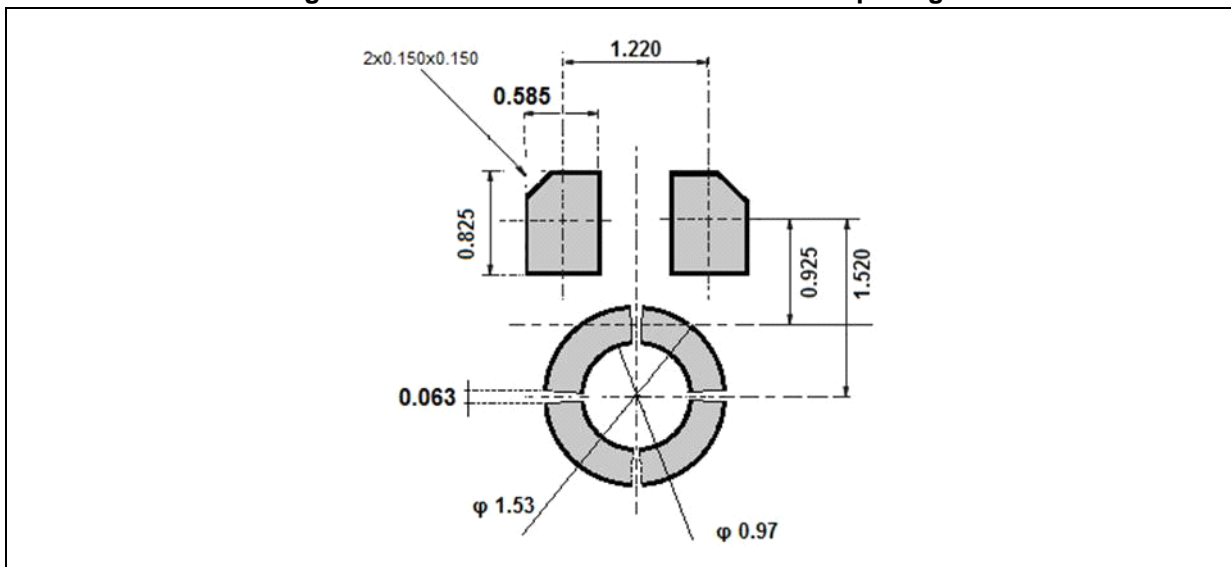

Figure 15. MP23AB02 recommended stencil openings



### 3 Process considerations

If self-cleaning solder paste is not used, proper cleaning of the board after soldering must be done to remove any possible source of leakage between pads due to flux residues. For the soldering profile, refer to the table and figure below.

**Table 1. Soldering profile**

Description	Parameter	Pb free
Average ramp rate	$T_L$ to $T_P$	3 °C/sec max
Preheat		
Minimum temperature	$T_{SMIN}$	150 °C
Maximum temperature	$T_{SMAX}$	200 °C
Time ( $T_{SMIN}$ to $T_{SMAX}$ )	$t_s$	60 sec to 120 sec
Ramp-up rate	$T_{SMAX}$ to $T_L$	
Time maintained above liquidus temperature	$t_L$	60 sec to 150 sec
Liquidus temperature	$T_L$	217 °C
Peak temperature	$T_P$	260 °C max
Time within 5 °C of actual peak temperature		20 sec to 40 sec
Ramp-down rate		6 °C/sec max
Time 25 °C ( $t_{25}$ °C) to peak temperature		8 minutes max

**Figure 16. Soldering profile**

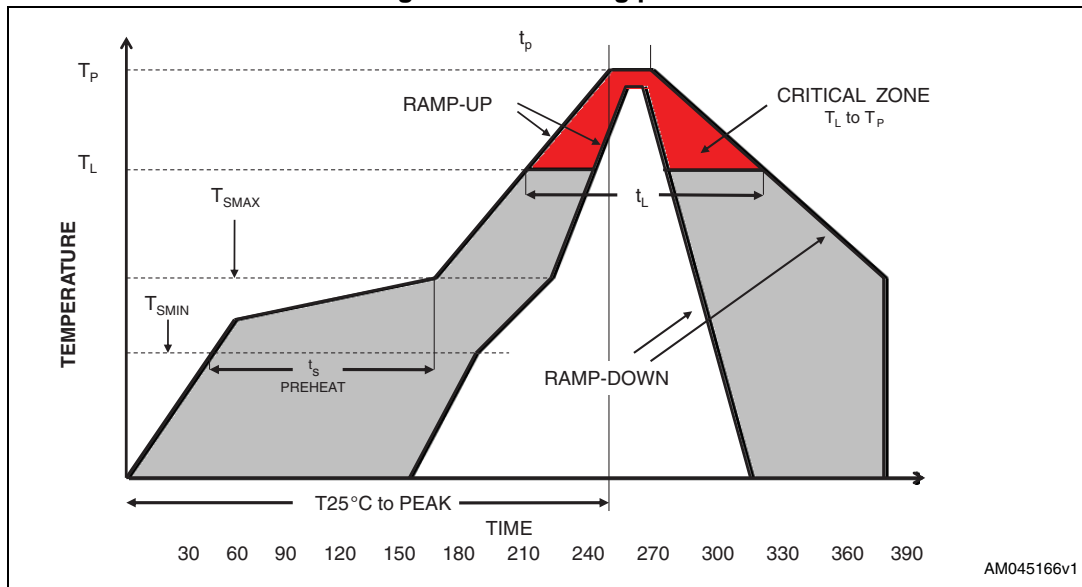

No solder material reflow on the side of the package is allowed since LGA packages show metal trace out of the package side.

## 4 Revision history

Table 2. Document revision history

Date	Revision	Changes
12-Mar-2013	1	Initial release.
21-Jul-2014	2	Added <a href="#">Section 2.5 on page 9</a> and <a href="#">Section 2.6 on page 10</a> .
08-Aug-2014	3	Modified <a href="#">Figure 11 on page 8</a> .

**IMPORTANT NOTICE – PLEASE READ CAREFULLY**

STMicroelectronics NV and its subsidiaries ("ST") reserve the right to make changes, corrections, enhancements, modifications, and improvements to ST products and/or to this document at any time without notice. Purchasers should obtain the latest relevant information on ST products before placing orders. ST products are sold pursuant to ST's terms and conditions of sale in place at the time of order acknowledgement.

Purchasers are solely responsible for the choice, selection, and use of ST products and ST assumes no liability for application assistance or the design of Purchasers' products.

No license, express or implied, to any intellectual property right is granted by ST herein.

Resale of ST products with provisions different from the information set forth herein shall void any warranty granted by ST for such product.

ST and the ST logo are trademarks of ST. All other product or service names are the property of their respective owners.

Information in this document supersedes and replaces information previously supplied in any prior versions of this document.

© 2014 STMicroelectronics – All rights reserved

