

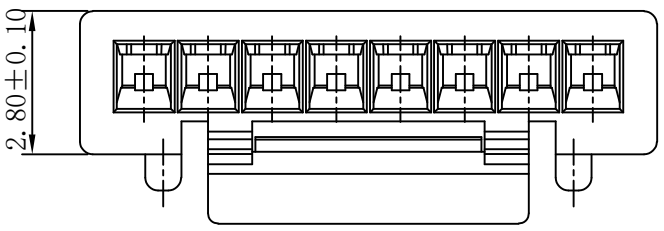

修订 REV	标记 MARK	修改摘要 REVISION DESCRIPTION	签名 SIGNATURE	日期 DATE
A0		NEW DWG		2010-09-21

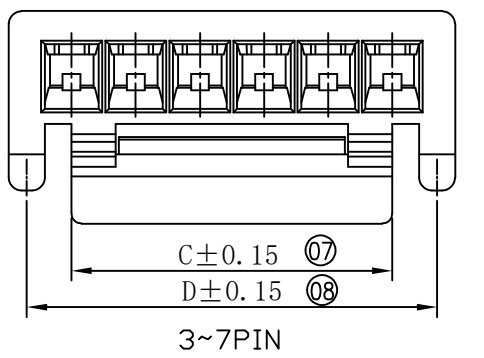

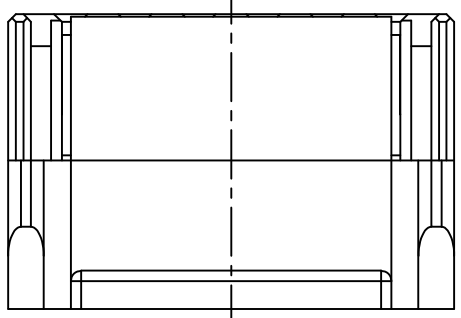
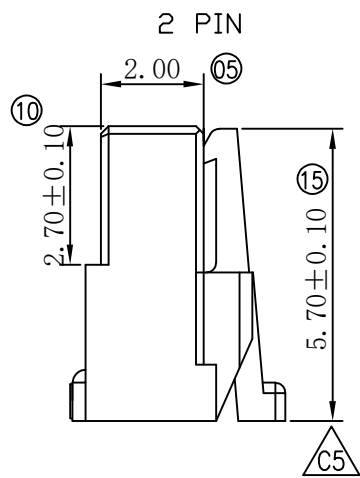
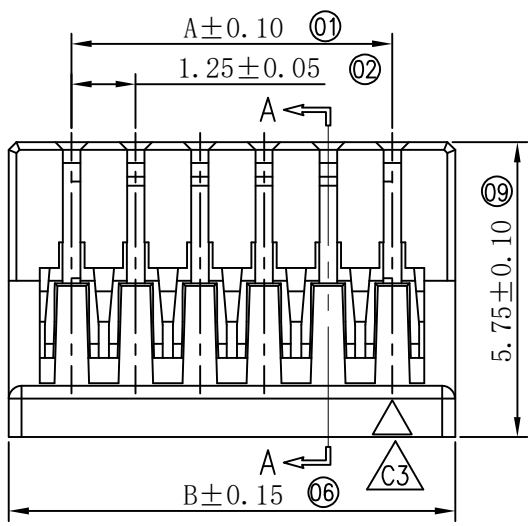
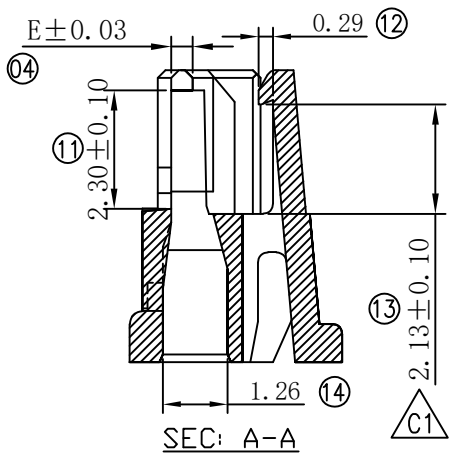
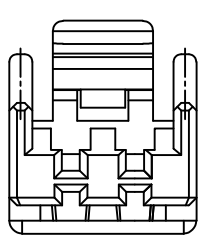
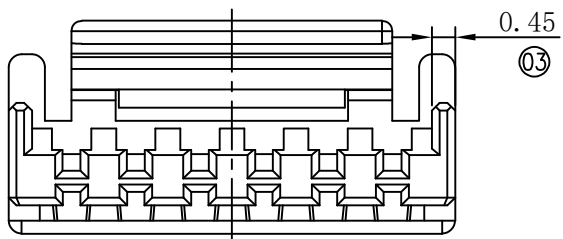

Dimensional Ordering Information					
Circuits Part No	Dimensions				
	A	B	C	D	E
2P	--	3.65	1.95	3.20	0.42
3P	2.50	4.90	3.00	4.20	0.42
4P	3.75	6.15	4.25	5.45	0.42
5P	5.00	7.40	4.25	6.70	0.42
6P	6.25	8.70	6.25	8.00	0.42
7P	7.50	9.95	6.25	9.25	0.42
8P	8.75	11.15	6.25	8.00	0.42
9P	10.00	12.40	6.25	8.00	0.42
10P	11.25	13.65	8.25	10.00	0.42
11P	12.50	14.90	8.25	10.00	0.42
12P	13.75	16.15	8.25	10.00	0.32
13P	15.00	17.40	8.25	10.00	0.32
14P	16.25	18.65	8.25	10.00	0.32
15P	17.50	19.90	8.25	10.00	0.32

产品要求:

材质: PA66 ,UL94V-0
外观要求: 外观无变形、缺胶等不良。



深圳市华德共创科技有限公司
Shenzhen Huade co-create Technology Co.,LTD
电话: 0755-27129737 传真: 0755-29940187

-TOLERANCES- UNLESS OTHERWISE SPECIFIED 公差参数表		 	TITLE: GH1.25胶壳 产品名称:				
X.X	±0.30	X.X*	±3'	APPD: 核准: 谢亮		PART NO: 产品编号: HDGC1257H-XP	
X.XX	±0.30	X.XX*	±2'	CHECK: 校对: 王建业		DATE	SCALE
X.XXX	±0.10	X.XXX*	±1'	DRAW: 绘图: 黄艳兰		UNIT	CODE NUMBER
				2010-09-21		1:1	mm
						A001	

修订 REV	标记 MARK	修改摘要 REVISION DESCRIPTION	签名 SIGNATURE	日期 DATE
AO		NEW DWG		2012-09-21

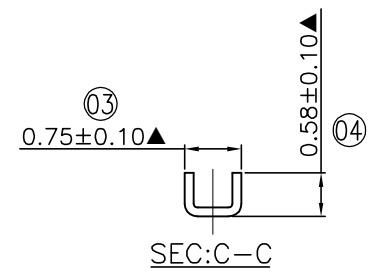
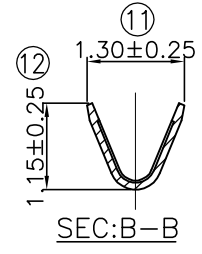
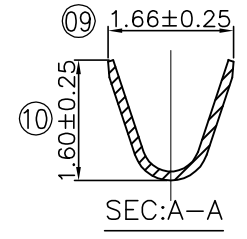
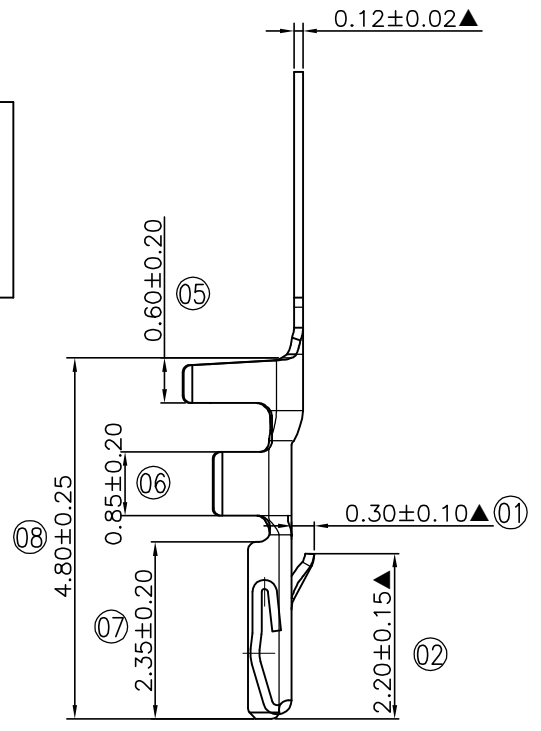
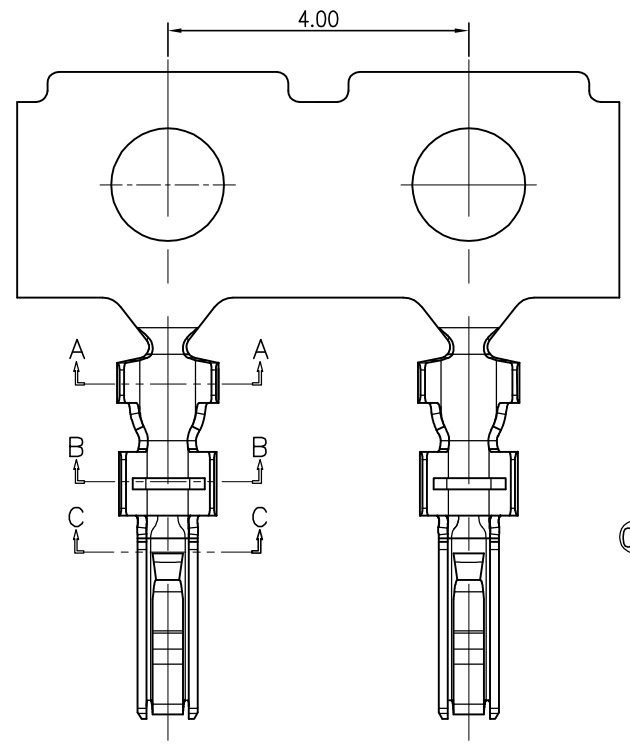

- 产品要求:
1. 材质: 磷铜 C5191 (T=0.12mm);
 2. 电镀标准: 先冲后镀 镀全锡 Ni底;
 3. 包装标准: 每盘20K;

 深圳市华德共创科技有限公司 Shenzhen Huade co-create Technology Co., LTD 电话: 0755-27129737 传真: 0755-29940187		TITLE: GH1.25-TER 产品名称:					
		PART NO: HDGC1257-T 产品编号:					
-TOLERANCES- UNLESS OTHERWISE SPECIFIED 公差参数表				DATE	SCALE	UNIT	CODE NUMBER
X.X	±0.30	X.X'	±3'	APPD: 核准: 谢亮			
X.XX	±0.30	X.XX'	±2'	CHECK: 校对: 王建业			
X.XXX	±0.10	X.XXX'	±1'	DRAW: 绘图: 黄艳兰	2012-09-21	1:1	mm A001