

## 1N4002GP ... 1N4007GP, 1N4002-Q ... 1N4007-Q

### Glass Passivated Silicon Rectifier Diodes Glaspassivierte Silizium-Gleichrichterdiodes

Version 2015-07-27

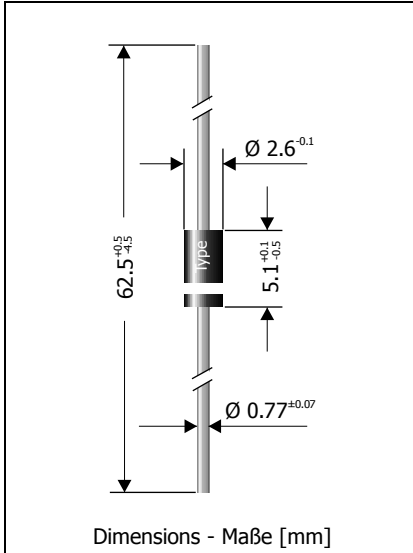

Nominal current Nennstrom	1 A
Repetitive peak reverse voltage Periodische Spitzensperrspannung	100...1000 V
Plastic case Kunststoffgehäuse	~DO-41 ~DO-204AC
Weight approx. Gewicht ca.	0.4 g
Plastic material has UL classification 94V-0 Gehäusematerial UL94V-0 klassifiziert	
Standard packaging taped in ammo pack Standard Lieferform gegurtet in Ammo-Pack	



#### Maximum ratings

#### Grenzwerte

Type Typ	Repetitive peak reverse voltage Periodische Spitzensperrspannung $V_{RRM}$ [V]	Surge peak reverse voltage Stoßspitzensperrspannung $V_{RSM}$ [V]
1N4002GP / 1N4002-Q	100	100
1N4004GP / 1N4004-Q	400	400
1N4005GP / 1N4005-Q	600	600
1N4007GP / 1N4007-Q	1000	1000

Max. average forward rectified current, R-load Dauergrenzstrom in Einwegschtung mit R-Last	$T_A = 75^\circ\text{C}$ $T_A = 100^\circ\text{C}$	$I_{FAV}$	1 A <sup>1)</sup> 0.8 A <sup>1)</sup>
Repetitive peak forward current Periodischer Spitzenstrom	$f > 15\text{ Hz}$	$I_{FRM}$	5.4 A <sup>1)</sup>
Peak forward surge current, 50/60 Hz half sine-wave Stoßstrom für eine 50/60 Hz Sinus-Halbwell	$T_A = 25^\circ\text{C}$	$I_{FSM}$	27/30 A
Rating for fusing – Grenzlastintegral, $t < 10\text{ ms}$	$T_A = 25^\circ\text{C}$	$i^2t$	3.6 A <sup>2</sup> s
Junction temperature – Sperrschichttemperatur Storage temperature – Lagerungstemperatur		$T_j$ $T_s$	-50...+175°C -50...+175°C

<sup>1</sup> Valid, if leads are kept at ambient temperature at a distance of 10 mm from case  
Gültig, wenn die Anschlussdrähte in 10 mm Abstand vom Gehäuse auf Umgebungstemperatur gehalten werden

**Characteristics**
**Kennwerte**

Forward voltage – Durchlass-Spannung	$T_j = 25^\circ\text{C}$	$I_F = 1\text{ A}$	$V_F$	$< 1.1\text{ V}$
Leakage current Sperrstrom	$T_j = 25^\circ\text{C}$ $T_j = 125^\circ\text{C}$	$V_R = V_{RRM}$ $V_R = V_{RRM}$	$I_R$ $I_R$	$< 5\ \mu\text{A}$ $< 50\ \mu\text{A}$
Reverse recovery time Sperrverzugszeit				$t_{rr}$ $< 2\ \mu\text{s}^1)$
Thermal resistance junction to ambient air Wärmewiderstand Sperrschicht – umgebende Luft				$R_{thA}$ $< 45\ \text{K/W}^2)$
Thermal resistance junction to leads Wärmewiderstand Sperrschicht – Anschlussdraht				$R_{thL}$ $< 15\ \text{K/W}$

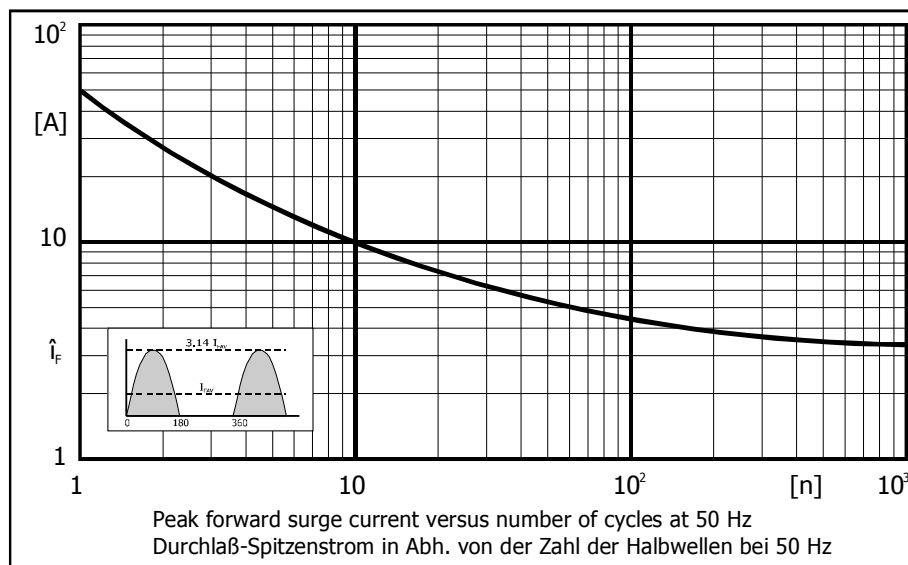
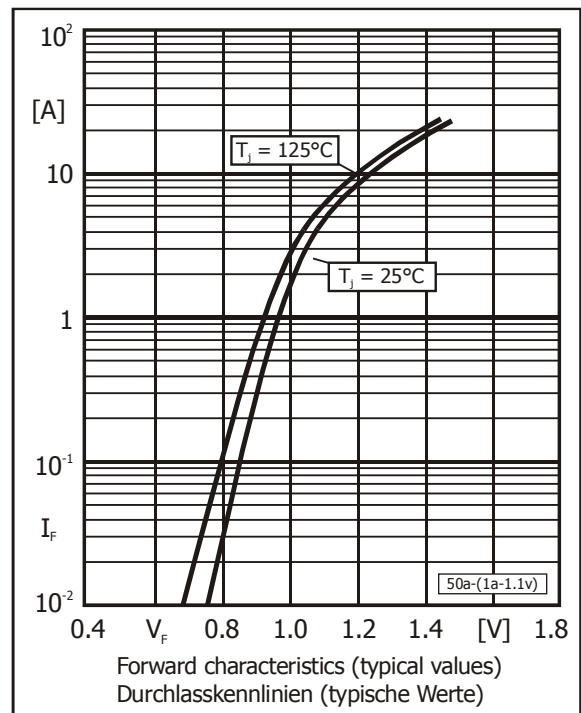
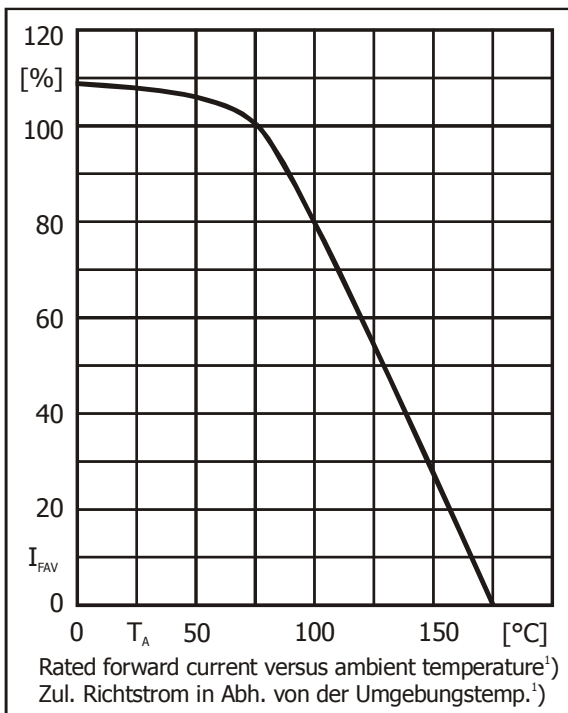

1  $I_F = 0.5\text{ A}$  through/über  $I_R = 1\text{ A}$  to/auf  $I_R = 0.25\text{ A}$

2 Valid, if leads are kept at ambient temperature at a distance of 10 mm from case  
Gültig, wenn die Anschlussdrähte in 10 mm Abstand vom Gehäuse auf Umgebungstemperatur gehalten werden