DRF5150S
Wireless Sensor Transmitter Module

V1.30

Features

- GFSK Transmitter module
- ISM frequency bands
- 81K bps data rate
- 10dBm output power
- Baud rate configurable
- 256 bytes data buffer
- Standby current < 2.5uA
- Supply voltage 2.1~3.6V



Application

- Temperature Measurement
- Humidity Measurement
- Wireless data logger
- Wireless sensor network

DESCRIPTION

DRF5150S is a type of low-cost sub-1 GHz transmitter module designed for operations in the unlicensed ISM (Industrial Scientific Medical) and LPRD bands. GFSK (Frequency Shift Keying) modulation/demodulation, multi-channel operation, high bandwidth efficiency and anti-blocking performance make DRF5150S modules easy to realize the robust and reliable wireless link.

The module integrates 12bit high resolution ADC which can be used to connect different types of analogue or digital sensors such as PT1000, DS18B20, SHT21/25, etc. Users don't need to write codes between sensor and DRF5150S module and no external MCU or other components needed. For the simplest application users can solder sensor on the pins of DRF5150 module to build a wireless sensor transmitting system easily. DRF5150S module can collect data from sensors and send it to transceiver module DRF4432S at configurable intervals, which minimizes the BOM cost and reduces development time for new projects.

The module can be configured to work in different channels with 200k Hz space. Through DRF Tool users also can change other parameters such as serial data rate, center frequency, output power, transmit interval, sensor types, etc. DRF5150S integrates 256 bytes buffer. When the buffer is empty, users can transfer 256 bytes data per time and even limitless data transfer can be achieved as long as RF data rate (RF module to RF module) is configured to be faster than serial data rate (MCU to RF module). DRF5150S operates at 2.1~3.6V with extra low standby current which makes it suitable for battery powered-up applications.

PIN FUNCTIONS

PIN	Name	Function	Data Mode	Sensor Mode
1	GND	Ground	Ground (0V)	Ground (0V)
2	VCC	Power	Power supply	Power supply
3	VCC	Power	Connected to Pin2 internally	Connected to Pin2 internally
4	RXD/AD1	In/Output	UART input; Pull-up resistor 22k	1. GIOP; pull-up resistor 22k 2. AD1 input; no pull-up needed
5	TXD/AD2	In/Output	Enable pin; pull-up resistor 22k High→sleep; Low→ work	1. GIOP; pull-up resistor 22k 2. AD2 input; no pull-up needed
6	AUX	Output	Data output indication	Sensor power supply control

Table 1: DRF5150S Pin Functions

ELECTRICAL SPECIFICATIONS

Symbol	Parameter (condition)	Min.	Typ.	Max.	Units
VCC	Supply Voltage	2.1	3.0	3.6	V
Temp	Operating temperature range	-30	25	85	°C
RH	Operating relative humidity	10		90	%
Freq	Frequency range	425	434	450	MHz
Mod	Modulation type		GFSK		
IDD_T	Current in transmit mode @10dBm/3V		14		mA
IDD_S	Current in sleep mode		1.5	2.5	uA
Pout	Output power @ 3.0V			10	dBm
DRFSK	GFSK data rate	3.125	50	81.25	Kbps
ZANT	Antenna Impedance		50		Ohm

Table 2: DRF5150S Electrical Specifications

ABSOLUTE MAXIMUM RATINGS

Symbol	Parameter	Min.	Max.	Units
VCC	Supply Voltage	-0.3	3.6	V
VI	Input voltage	-0.3	VCC+0.3	V
VO	Output voltage	-0.3	VCC+0.3	V
TST	Storage temperature	-55	125	°C

Table 3: DRF5150S Maximum Ratings

SETTING PARAMETERS**1. Default Values**

Parameter	Option	Default Value	Unit
Tx interval	1 ~ 120	4	Second
Parity Check	No check, Even parity, Odd parity	No check	
Frequency	425 ~ 450MHz	434	MHz
GFSK data rate	3.125~81.25	50	Kbps
Group ID	0 ~ 255	123	

Table 4: DRF5150S Default Settings**2. Parameter Setting**

Users can configure the parameters (frequency, data rate, group ID, etc.) of DRF modules with RS232 converter board DAC01 or USB converter board DAC02 by configuration tool DRF TOOL5150. Because DRF4432S shares the same configuration tool with DRF5150S, some parameters such as slave ID, Tx interval, etc are not applicable for receiver module DRF5150S.

Firstly users need to insert module into converter board, connect converter board to PC and then open DORJI RF software. In Windows XP system, the software can be run directly but in Windows Vista/7 system users should run it as administrator. After that the status column of tool should display "Found Device". Users then can read/write the module. For more details, please check the operation manuals of converter boards on accessory page.

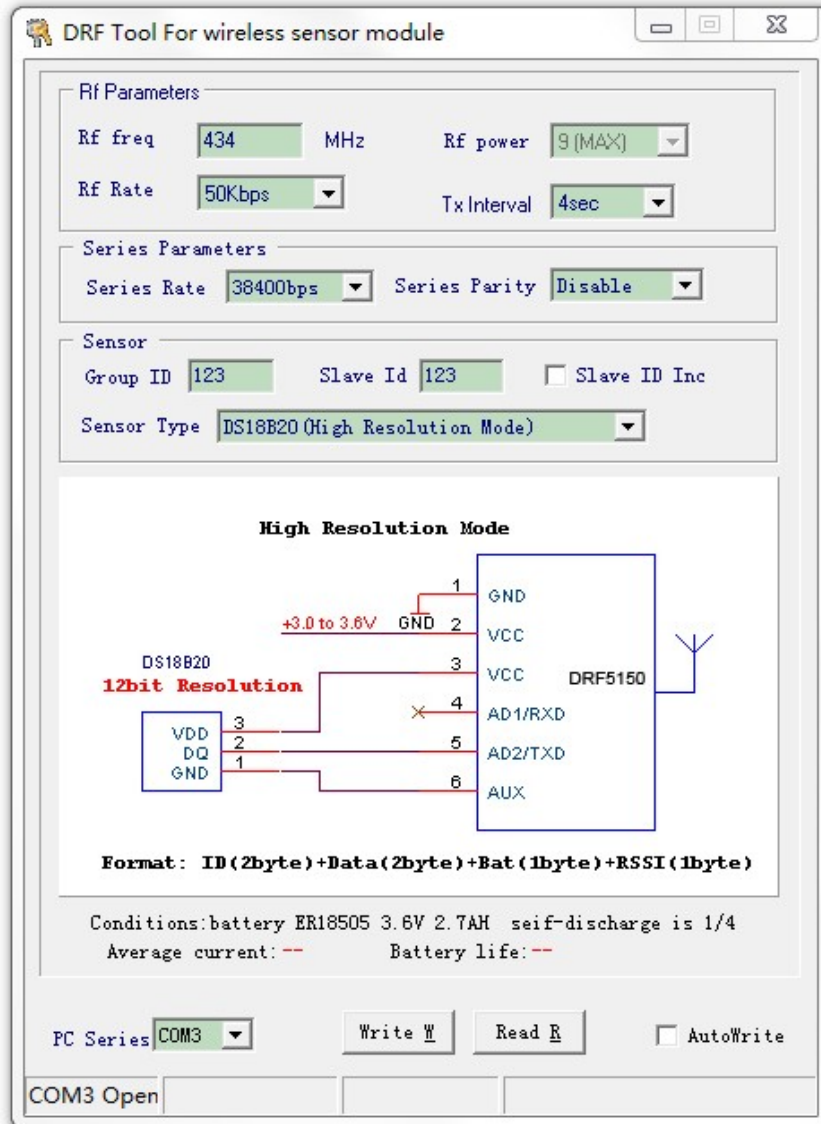

Figure 1: DRF TOOL 5150/4432

WORKING MODES

DRF5150S modules can work in two modes: Data transmission mode and Sensor data mode. In data transmission mode DRF5150S module acts as transparent data transmitter and it receives data from MCU or other hosts and then sends them to other modules. Under sensor data mode, DRF5150S can sample signal from two input pins, process and then send to other modules.

1. DATA TRANSMISSION MODE

In this mode DRF5150S module is common data transmitter module. It doesn't contain ID will not transmit data automatically at the preset interval. The 5th pin is used as enable pin.

When it is in high level, the module will enter into sleep mode and the current is about 1.5uA. When the 5th pin is connected to low the module will work in receive mode. The 6th pin will be set to low when DRF5150S receives the first byte of data and it will be set to high after transmission is finished so it can be used to monitor transmit status. The module will detect the status of the 5th pin after transmission is finished so users can set the 5th pin to high after MCU sends out all the data.

If the data package is less than 60 bytes DRF5150S module will begin to transmit after the whole package is received. If the data package size is larger than 60 bytes it will split the package into smaller package size (60 bytes) and send them out serially. DRF5150S integrates 256 bytes buffer. If the buffer is empty users can send 256 bytes of data one time. When the RF GFSK data rate is faster than serial data rate the size of data package can be limitless.

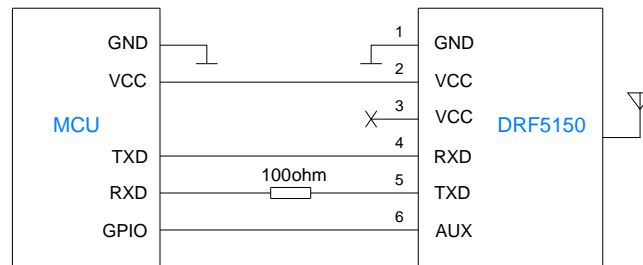

Figure 2: DRF5150S in Data Transmission Mode

2. SENSOR DATA MODE

In this mode DRF5150S module contains ID and it will transmit at the preset interval. The ID includes two parts: Group ID and Slave ID. The transceiver module DRF4432S will be used as receiver module. When the group ID of DRF4432S is the same as DRF5010S10's or its ID is 0x00, it can receive the data sent from DRF5150S and will append RSSI information to the data package and then transfer the processed data to MCU. In order to avoid data bump, DRF5150S transmits randomly in the period of $\pm 10\% \cdot \text{interval}$.

For example: If the Tx interval is set to 1s, the DRF5150S module will transmit randomly between 0.9s and 1.1s.

Because of short data package, the feature can let many DRF5150S modules work with the same settings with little interference and DRF4432S module can read the data correctly.

The transmitted data format of DRF5150S: ID (group ID+ Slave ID)+ Data+ Bat

The output data format of DRF4432S: ID (group ID + slave ID) +Data + Bat + RSSI

Data Format	Group ID	Slave ID	Data	Bat	RSSI
Length(byte)	1	1	2~4	1	1

Table 5: DRF5150S Data Format

The data package varies between 2 and 4 bytes and its length will depend on the selection of sensor type from the configuration tool. Bat is one byte of battery information. The calculation function is: Battery voltage= (Bat+200)/100.

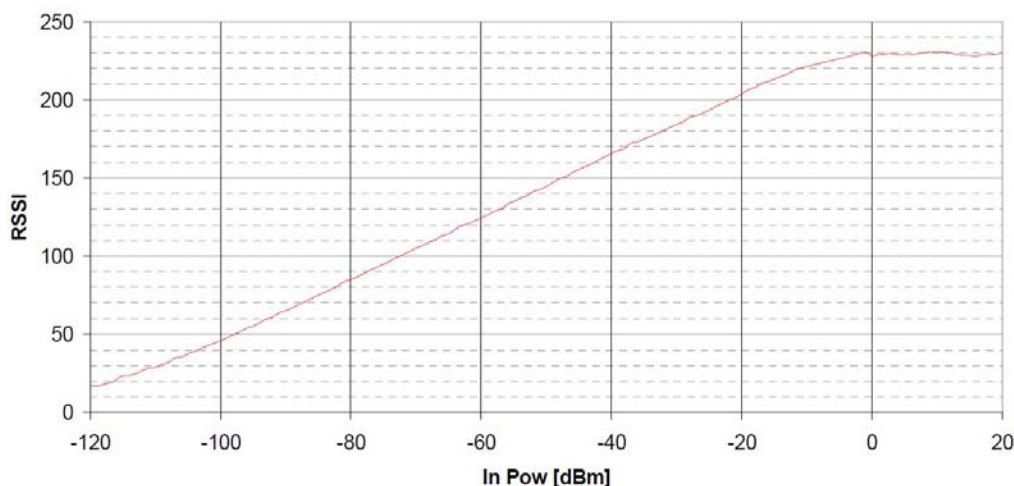

Figure 3: RSSI vs Input Power

The relationship of the field strength of received signal (RSSI) and input power is shown as the picture above. The higher value of RSSI means more reliable wireless link. If the RSSI < 0x40 at 50K bps RF data rate or RSSI < 0x30 at 6.25k bps RF data rate, it means the field strength is too weak and the probability of package loss will increase.

DRF5150S integrates a 12bit ADC. When connecting to analogue sensor, the output data is 2 bytes which ranges from 0x0000~0xFFFF. For digital sensors DRF5150S module will read out data without process so users can refer to the datasheets of corresponding sensors and make calculation.

1) Analogue Sensor Mode

In this mode DRF5150S module will use integrated 12bit ADC. The 5th pin will be used as analogue input and Vref will be connected to VCC pin. The module will sample the analogue signal at intervals.

When one Tx interval finishes, the module firstly set the 6th pin AUX from High to Low. After 1ms the internal ADC will sample 6 times and then set AUX to High. After removing the highest and the lowest values, the module will output the average of 4 sampling values. Users can connect a analogue sensor such as PT1000 and connect a high resolution resistor between the 5th pin and the 6th pin. The value of resistor is usually equal to the resistance of analogue sensor. The Max. drive-in of the 6th pin AUX is 20mA. Being connecting different resistors the voltage drop on AUX has slightly difference so

users can make compensation in calculating to get a higher resolution. The reference connection diagram in analogue sensor mode is showed as below.

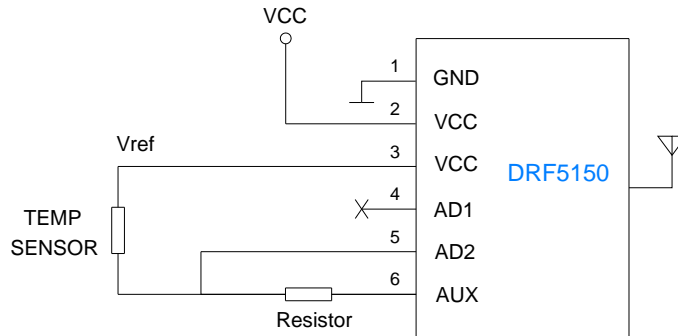

Figure 4: DRF5150S in Analogue Sensor Mode

2) DS18B20 Mode

DS18B20 is a type of high resolution digital temperature sensor from Maxim. It works at 3.0~5.0V and the measurement range is $-55\sim+125^{\circ}\text{C}$ with $\pm 0.5^{\circ}\text{C}$ accuracy. It can be connected to DRF5150S module without extra components. DRF5150S supports 9 bit low resolution and 12bit high resolution measurement. DS18B20 consumes about 1mA current in work mode. The measurement time for low resolution mode is 93.75ms and 750ms for high resolution mode. Applications which are sensitive to power consumption might choose low resolution mode to have a better battery life time. DRF5150S module will send temperature data: Byte0 (LSB) and Byte1 (MSB) at intervals.

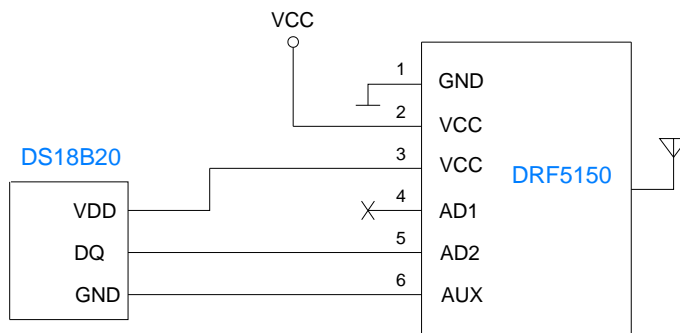

Figure 5: DRF5150S in DS18B20 Sensor Mode

3) SHT2x & SHT1x Mode

SHT1x and SHT2x sensor from SENSIRION integrate temperature and humidity function. They can be connected to DRF5150S module directly. According to the

specification of sensors a filtering capacitor is needed to be connected between VCC and GND. For SHT1x series of sensor, DRF5150S module support high resolution measurement. As to SHT2x series of sensors, it also supports two measurement modes: low resolution and high resolution.

When the distance between digital sensor and DRF5150S module is less than 30cm, no pull-up resistor is needed. However when the distance exceeds 30cm, the distributed capacitance must be taken into consideration. The pull-up resistors are needed to add and the actual values of resistors will be selected according to the specifications of sensor products but the Max. distance should not exceed 2m. The 6th pin AUX is connected to the GND of digital sensor so it will be kept in low in use. Users also can choose connect the GND of digital sensors to the GND of DRF5150S module and keep AUX suspended.

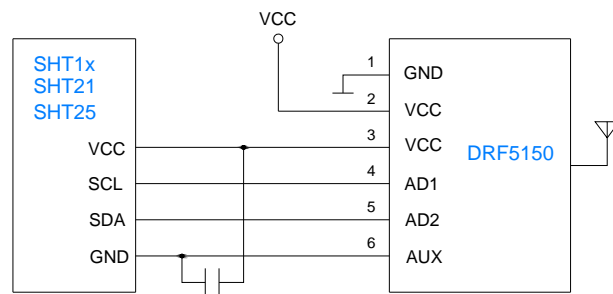

Figure 6: DRF5150S in SHTxx Sensor Mode

MECHANICAL DATA

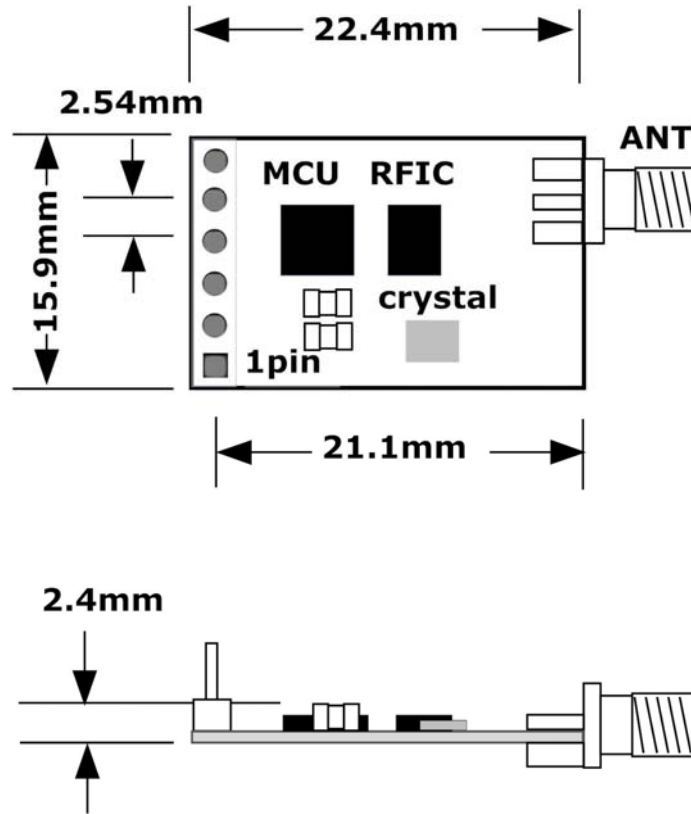

Figure 7: Mechanical Dimension

ORDERING INFORMATION

DRF 5150 S 10 — 043 A

- ① ② ③④ ⑤ ⑥

Num	Symbol	Meaning
①	RF module	DORJI RF module
②	IC Type	TDA5150
③	Module Function	Sensor module
④	Power	10dBm output power
⑤	Freq. Band	043: 433MHz 086:869Mhz 091:915Mhz
⑥	Package	DIP package with SMA connector

Table 6: Ordering Information

<p>Dorji Applied Technologies A division of <i>Dorji Industrial Group Co., Ltd</i></p> <p>Add.: Xinchenuayuan 2, Dalanganlu, Longhua, Baoan district, Shenzhen, China 518109</p> <p>Tel: 0086-755-28156122 Fax.: 0086-755-28156133 Email: sales@dorji.com Web: http://www.dorji.com</p>	<p>Dorji Industrial Group Co., Ltd reserves the right to make corrections, modifications, improvements and other changes to its products and services at any time and to discontinue any product or service without notice. Customers are expected to visit websites for getting newest product information before placing orders.</p> <p>These products are not designed for use in life support appliances, devices or other products where malfunction of these products might result in personal injury. Customers using these products in such applications do so at their own risk and agree to fully indemnify Dorji Industrial Group for any damages resulting from improper use.</p>
---	---