

### ■ 技术参数 SPECIFICATIONS

- 线数 (Poles) : 2~12
- 适用线规 (Applicable wires) : AWG28#~20#
- 适应基板厚度 (Applicable PC board thickness) : 0.5~2.0mm
- 温度范围 (Temperature range) : -25°C~85°C
- 额定电压 (Voltage rating) : 250V.Ac/Dc
- 额定电流 (Current rating) : 3A Max
- 接触电阻 (Contact resistance) : ≤0.02Ω
- 绝缘电阻 (Insulation resistance) : ≥1000MΩ
- 耐压 (Withstand voltage) : 1000V.Ac/1min
- 材料 (Material) :
  - 插头 (Plug housing) : 尼龙 (PA66) UL94V-2(0)
  - 插座 (Receptacle housing) : 尼龙 (PA66) UL94V-2(0)
  - 插片 (Retainer) : 尼龙 (PA66) UL94V-2(0)
  - 端子 (Terminal) : 磷青铜 (Phos.bronze Tin/plated)

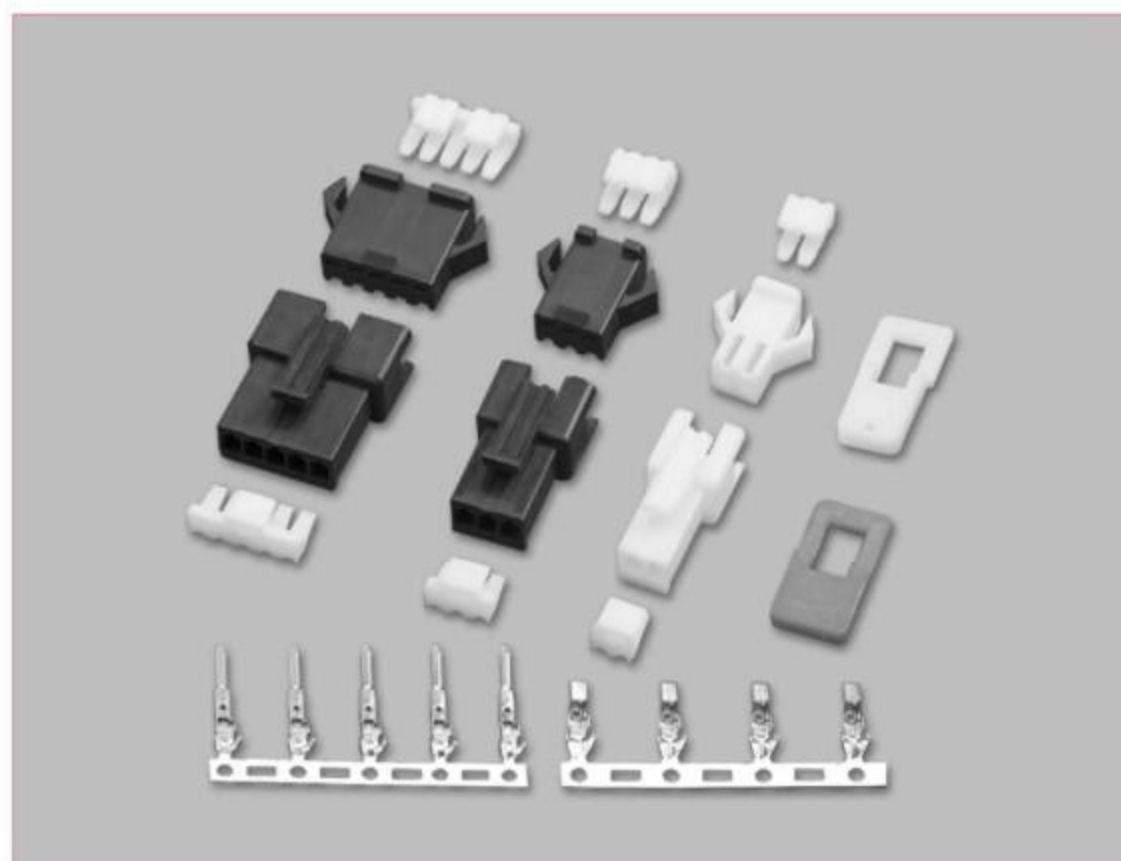

### 端子 TERMINAL(SM)

线数 Poles	型号 Type	适应基板厚度 Applicable PC board thickness(mm)					
		0.5~0.9		1.0~1.5		1.5~2.0	
		A	B	A	B	A	B
2	HX25022-2P	5.7	9.6	5.7	9.8	5.7	10.0
3	HX25022-3P	8.2	12.1	8.2	12.3	8.2	12.5
4	HX25022-4P	10.7	14.6	10.7	14.8	10.7	15.0
5	HX25022-5P	13.2	17.1	13.2	17.3	13.2	17.5
6	HX25022-6P	15.7	19.6	15.7	19.8	15.7	20.0
7	HX25022-7P	18.2	22.1	18.2	22.3	18.2	22.5
8	HX25022-8P	20.7	24.6	20.7	24.8	20.7	25.0
9	HX25022-9P	23.2	27.1	23.2	27.3	23.2	27.5
10	HX25022-10P	25.7	29.6	25.7	29.8	25.7	30.0
11	HX25022-11P	28.2	32.1	28.2	32.3	28.2	32.5
12	HX25022-12P	30.7	34.6	30.7	34.8	30.7	35.0

型号 Type	适用线规 Applicable wires		电线外径 O.D of wire ins mm	数量 Quantity
	mm <sup>2</sup>	AWG#		
HX25022-21PT	0.08~0.33	28~22	1.0~1.8	4500PCS/盘
HX25023-21RT	0.08~0.33	28~22	1.0~1.8	7000PCS/盘
HX25022-31PT	0.3~0.5	22~20	1.5~2.0	4500PCS/盘
HX25023-31RT	0.3~0.5	22~20	1.5~2.0	7000PCS/盘

### HX25023-2GRS (SM)

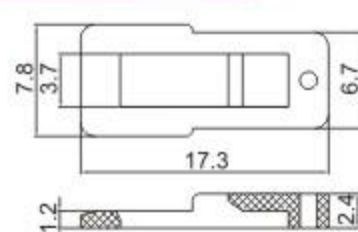

钩锁片: 适配SM-2R钩

### HX25023-GRS (SM)

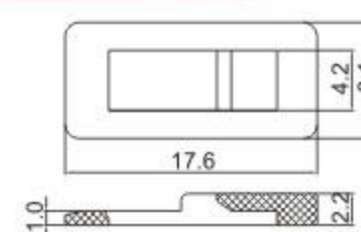

钩锁片: 适配SM-3-12R钩

### ■ 安装尺寸 MOUNTING MEASUREMENT

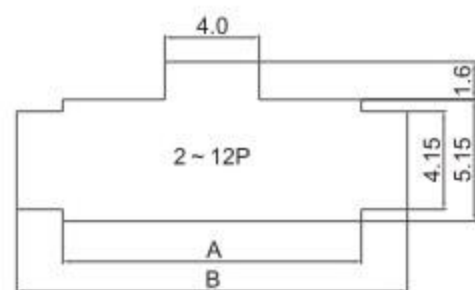

### HX25022-PT (SM)

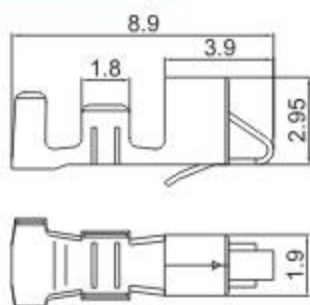

### HX25023-RT (SM)

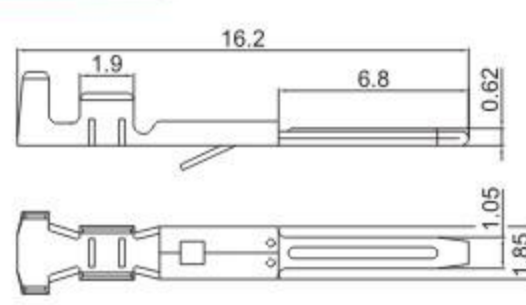

线数 (Poles)	插头插片 (Retainer)	插头 (Plug housing)	插座 (Receptacle housing)	插座插片 (Retainer)
2	HX25022-2PS (SM) 	HX25022-2P (SM) 	HX25023-2R (SM) 	HX25023-2RS (SM) 
	HX25022-2PF (SM) 	HX25022-2PF (SM) 	HX25023-2RF (SM) 	HX25023-2RF (SM) 
3	HX25022-3PS (SM) 	HX25022-3P (SM) 	HX25023-3R (SM) 	HX25023-3RS (SM) 
	HX25022-3PF (SM) 	HX25022-3PF (SM) 	HX25023-3RF (SM) 	HX25023-3RF (SM) 