

Applications

- High Performance Supertrunking Links
- High Power Distribution Networks
- Redundant Ring Architectures
- FTTx Networks
- Fiber Deep Architectures

Features

- Full Function Fiber Optic Amplifier Ready for Integration
- Low Noise Figure (Typ ≤ 6.0 dB)
- Pin: -10 dBm to $+12$ dBm
- Pout: $+27$ dBm to $+37$ dBm
- Standard RS-232 Communication
- Low Electrical Power Consumption
- Input/Output Isolation $\geq 40/40$ dB
- Polarization Dependant Gain (PDG) ≤ 0.1 dB
- Polarization Mode Dispersion (PMD) ≤ 0.5 ps
- Input & Output Return Losses ≤ -40 dB
- Wavelength: 1545 nm to 1562 nm

MAFA 3000 Series Erbium Doped Fiber Micro Amplifier

EMCORE's MAFA 3000 Series Erbium Doped Fiber Amplifier (EDFA) Gain Block Module is an ideal building block for OEM system integrators. The family of MAFA 3000 EDFA Gain Blocks is designed to meet the most demanding noise performance requirements of special and CATV applications, and performs all the functions required of a high power optical amplifier for system integration.

MAFA 3000 series EDFA Gain Blocks provide optical isolation on the input and output of the gain block for stable, low noise operation. The input and output optical signal power levels are detected for monitoring and control. The input optical signal is amplified with active gain control for a constant output power level or with active output power control for constant gain mode operation.

The MAFA 3000 series EDFA Gain Blocks also provide monitors and associated alarms for all vital characteristics. The optical output of the MAFA 3000 series EDFA Gain Blocks can be split into multiple ports by an optional external splitter. Small mechanical footprint allows using this unit in very tight space environments.

Optical/Electrical Characteristics¹

Property	Unit	Limit	Models						Comments
			3037	3030	3032	3033	3035	3037	
Operating Input Power	Pin (dBm)	Max	12	12	12	12	12	12	
Operating Input Power	Pin (dBm)	Min	-10	-10	-10	-10	-10	-10	Typical (May vary for some models)
Output Power	Po (dBm)	Nominal	27.0	30.0	32.0	35.0	35.0	37.0	Note 2
Noise Figure	NF (dB)	Typ/Max	5.5/6.0	5.5/6.0	5.5/6.0	5.5/6.0	5.5/6.0	5.5/6.0	(Notes 3)
Static Gain Flatness	ΔG_s (dB)	Max	+/-2.0	+/-2.0	+/-2.0	+/-2.0	+/-2.0	+/-2.0	(Notes 4)
Dynamic Gain Flatness	ΔG_d (dB)	Max	+/-2.5	+/-2.5	+/-2.5	+/-2.5	+/-3.0	+/-3.0	(Notes 5)
Output Power Stability	(dB)	Max	+/- 0.2	+/- 0.2	+/- 0.2	+/- 0.2	+/- 0.2	+/-0.2	(Note 6)
Power Consumption (Steady state)	Psys(W)	Max	20 12	28 18	35 25	45 35	48 38	55 45	70°C Case (Premium) 55°C (Economy)
Remnant Pump Power to Output	Prp (dBm)	Nom	\leq -30	\leq -30	\leq -30	\leq -30	\leq -30	< -30	

Notes:

1. Unless stated otherwise, all specifications apply over the full operating temperature and humidity ranges
2. Depending on the fiber optic patchcord interface the measured value can vary up to 0.5 dB from the actual value.
3. Measured with input optical signal with Pin \approx 0 dBm and $\lambda \approx$ 1550 nm @ 25°C. May vary for some models.
4. Measured with a swept Probe Signal (Pp), where Pp \approx 0 dBm @ 25°C. May vary for some models.
5. Measured with a swept Probe Signal (Pp), and a fixed Tone Signal (Pt) @ \sim 1550 nm; (Pt \approx Pp+20 dB; Pt + Pp \approx 0 dBm) @ 25°C
6. Over polarization and specified temperature range.
7. Premium version – MAFA (with cooled pumps).
Economy version – MAFA (with uncooled pumps).

General and Mechanical Specifications

Property	Requirement	Comments
Operating Wavelength	1545 nm ~ 1562 nm	Standard
Operating Case Temperature	-40°C to 75°C -10°C to 65°C	Premium Economy
Storage Temperature	-40°C to 85°C	
Operating Humidity	20% to 85%	Non-condensing
Voltage Supply Range	+5.0V +/-5%	All versions
	+24V +/-5%	All versions (efficiency: 75% for MAFA 3030; 90% for MAFA 3037)
Optical Connectors	SC/APC; FC/APC; E2000/APC	User Specified (for MAFA 3032, MAFA 3033, MAFA 3035 and MAFA 3037, if used separately, only special high power patchcord is absolutely recommended)
Dimensions (in)	9.5"W x 6.7"D x 1.5"H	MAFA 3030 to MAFA 3037 Unit height depends on heatsink used

Outline Drawing

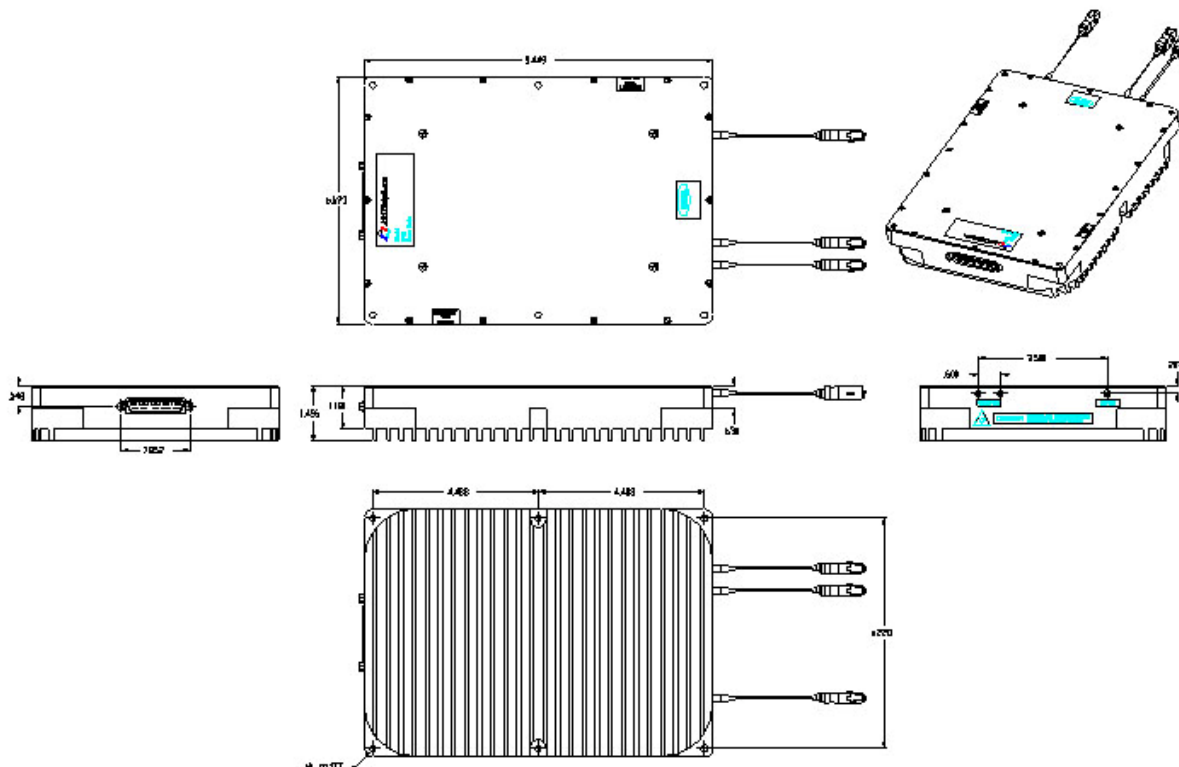

Electrical Connector Pinout

PIN #	Designation	PIN #	Designation
1	DC Power Input (+5V/+24V)	16	GND
2	DC Power Input (+5V/+24V)	17	GND
3	DC Power Input (+5V/+24V)	18	RS-232 Tx
4	DC Power Input (+5V/+24V)	19	Reserved*
5	KEY-SWITCH	20	Output Optical Power Mute
6	Reserved*	21	Amplifier Disable Input
7	Reserved*	22	RS-232 Rx
8	Reserved*	23	Reserved*
9	Reserved*	24	DC Power Input (+5V/+24V)
10	Reserved*	25	GND
11	Reserved*		
12	DC Power Input (+5V/+24V)		
13	GND		
14	GND		
15	GND		

Compliance and Reliability Information

EN 55013: Sound and Television Broadcast receivers and associated equipment – Radio disturbance characteristics – limits and methods of measurements – Electric Field Radiation Emissions (2001)

FCC: Subpart B. Part 15 class “A”: Unintentional Radiators

EN 61000-4-3 Radiated Immunity

EN 55020 Conducted Immunity

EN 61000-3-2 Harmonics

EN 50083-2, 1995 with Amendment 1

Fit Rate: 90% level of confidence <3500 @ 30°C

Ordering Information

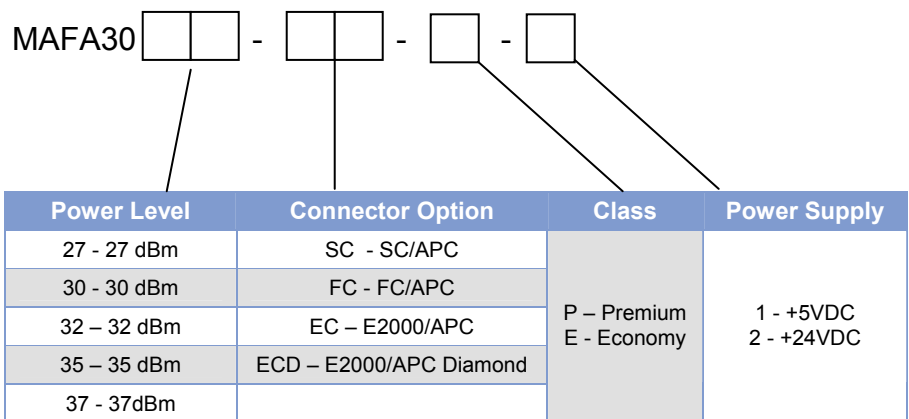

Example:

MAFA3032-SC-E-1: 32 dBm EDFA Gain Block with SC/APC connectors, Economy pumps, +5VDC Power Supply

Note:

As shown on the outline drawing above the option with 2 optical output ports is also possible.