



# AC '97 and HD Audio SoundMAX Codec

## AD1986A

### FEATURES

- Supports both AC '97 and HD audio interfaces
- 6 DAC channels for 5.1 surround
- S/PDIF output
- Integrated headphone amplifiers
- Variable rate audio
- Double rate audio ( $F_s = 96$  kHz)
- Greater than 90 dB dynamic range
- 20-bit resolution on all DACs
- 20-bit resolution on all ADCs
- Line-level mono phone input
- High quality differential CD input
- Selectable MIC input with preamp
- AUX and line-in stereo inputs
- External amplifier power down (EAPD)
- Power management modes
- Jack sensing and device identification
- 48-lead LQFP package

### ENHANCED FEATURES

- Integrated parametric speaker equalizer
- Stereo microphone with up to 30 dB gain boost
- Integrated PLL for system clocking
- Variable sample rate: 7 kHz to 96 kHz
  - 7 kHz to 48 kHz in 1 Hz increments
  - 96 kHz for double rate audio
- Jack sense with autotopology switching
- Jack presence detection on up to 8 jacks
- Three software-controlled microphone bias signals
- Software-enabled outputs for jack sharing
- Auto-down mix and channel spreading
- Microphone-to-mono output for speakerphone
- Stereo microphone pass-through to mixer
- Built-in microphone/center/LFE/line-in sharing
- Built-in SURROUND/LINE\_IN sharing
- Center/LFE swapping supporting all vendor speakers
- Microphone left/right swapping
- Reduced support component count
- General-purpose digital output pin (GPO)
- LINE\_OUT and HP\_OUT, headphone drive on both

### Rev. 0

Information furnished by Analog Devices is believed to be accurate and reliable. However, no responsibility is assumed by Analog Devices for its use, nor for any infringements of patents or other rights of third parties that may result from its use. Specifications subject to change without notice. No license is granted by implication or otherwise under any patent or patent rights of Analog Devices. Trademarks and registered trademarks are the property of their respective owners.

One Technology Way, P.O. Box 9106, Norwood, MA 02062-9106, U.S.A.  
Tel: 781.329.4700 [www.analog.com](http://www.analog.com)  
Fax: 781.461.3113 © 2005 Analog Devices, Inc. All rights reserved.

## TABLE OF CONTENTS

Functional Block Diagram .....	4	Surround DAC PCM Rate (Register 0x2E).....	34
Specifications.....	5	C/LFE DAC PCM Rate (Register 0x30).....	34
Absolute Maximum Ratings.....	9	ADC PCM Rate (Register 0x32) .....	34
Environmental Conditions.....	9	C/LFE DAC Volume (Register 0x36).....	35
ESD Caution.....	9	Surround DAC Volume (Register 0x38).....	35
Pin Configuration And Function Description .....	10	SPDIF Control (Register 0x3A).....	36
AC'97 Registers .....	12	EQ Control Register (Register 0x60).....	37
HD Audio Widgets .....	14	EQ Data Register (Register 0x62) .....	38
AC '97 Register Details .....	21	Misc Control Bits 2 (Register 0x70).....	38
Reset (Register 0x00).....	21	Jack Sense (Register 0x72).....	39
Master Volume (Register 0x02) .....	21	Serial Configuration (Register 0x74).....	41
Headphone Volume (Register 0x04) .....	22	Misc Control Bits 1 (Register 0x76).....	43
Mono Volume (Register 0x06).....	22	Advanced Jack Sense (Register 0x78) .....	45
PC Beep (Register 0x0A).....	23	Misc Control Bits 3 (Register 0x7A).....	45
Phone Volume (Register 0x0C) .....	23	Vendor ID Registers (Register 0x7C to 0x7E) .....	47
Microphone Volume (Register 0x0E) .....	24	Codec Class/Revision Register (Register 0x60) .....	47
Line_In Volume (Register 0x10).....	25	PCI Subsystem Vendor ID Register (Register 0x62, Page 01).....	48
CD Volume (Register 0x12) .....	25	PCI Subsystem Device ID Register (Register 0x64, Page 01).....	48
AUX Volume (Register 0x16).....	26	Function Select Register (Register 0x66, Page 01) .....	49
Front DAC Volume (Register 0x18).....	26	Information and I/O Register (Register 0x68, Page 01) .....	50
ADC Select (Register 0x1A).....	27	Sense Register (Register 0x6A, Page 01).....	51
ADC Volume (Register 0x1C) .....	28	Jack Presence Detection.....	53
General-Purpose (Register 0x20).....	29	Audio Jack Styles (NC/NO) .....	53
Audio Int and Paging (Register 0x24) .....	29	Microphone Selection/Mixing.....	54
Power-Down Ctrl/Stat (Register 0x26).....	30	Outline Dimensions .....	55
Extended Audio ID (Register 0x28).....	31	Ordering Guide .....	55
Ext'd Audio Stat/Ctrl (Register 0x2A).....	32		
Front DAC PCM Rate (Register 0x2C) .....	33		

## REVISION HISTORY

4/05—Revision 0: Initial Version

## NOTES

### REDUCED SUPPORT COMPONENTS

The AD1986A includes many improvements that reduce external support components for particular applications.

- **Multiple Microphone Sourcing:** The MIC\_1/2, LINE\_IN and C/LFE pins can all be selected as sources for microphone input (boost amplifier).
- **Multiple VREF\_OUT Pins:** Each microphone-capable pin group (MIC\_1/2, LINE\_IN and C/LFE) has separate, software controllable VREF\_OUT pins, reducing the need for external biasing components.
- **Internal Microphone Mixing:** Any combination of the MIC\_1/2, LINE\_IN and C/LFE pins can be summed to produce the microphone input. This removes the need for external mixing components in applications that externally mix microphone sources.
- **Advanced Jack Presence Detection:** Using two codec pins, eight resistors and isolated switch jacks, the AD1986A can detect jack insertion on eight separate jacks.
- **Internal Microphone/Line In/C/LFE Sharing:** On systems that share the microphone with the C/LFE jack no external components are required. The microphone selector can select the LINE\_IN pins when the microphone and line input devices are swapped.
- **Internal Line In/Microphone/Surround Sharing:** On systems that share the line in with the surround jack no external components are required.
- **Dual Headphone Amplifiers:** The AD1986A can drive headphones out of the HP\_OUT or LINE\_OUT pins.

# AD1986A

## FUNCTIONAL BLOCK DIAGRAM

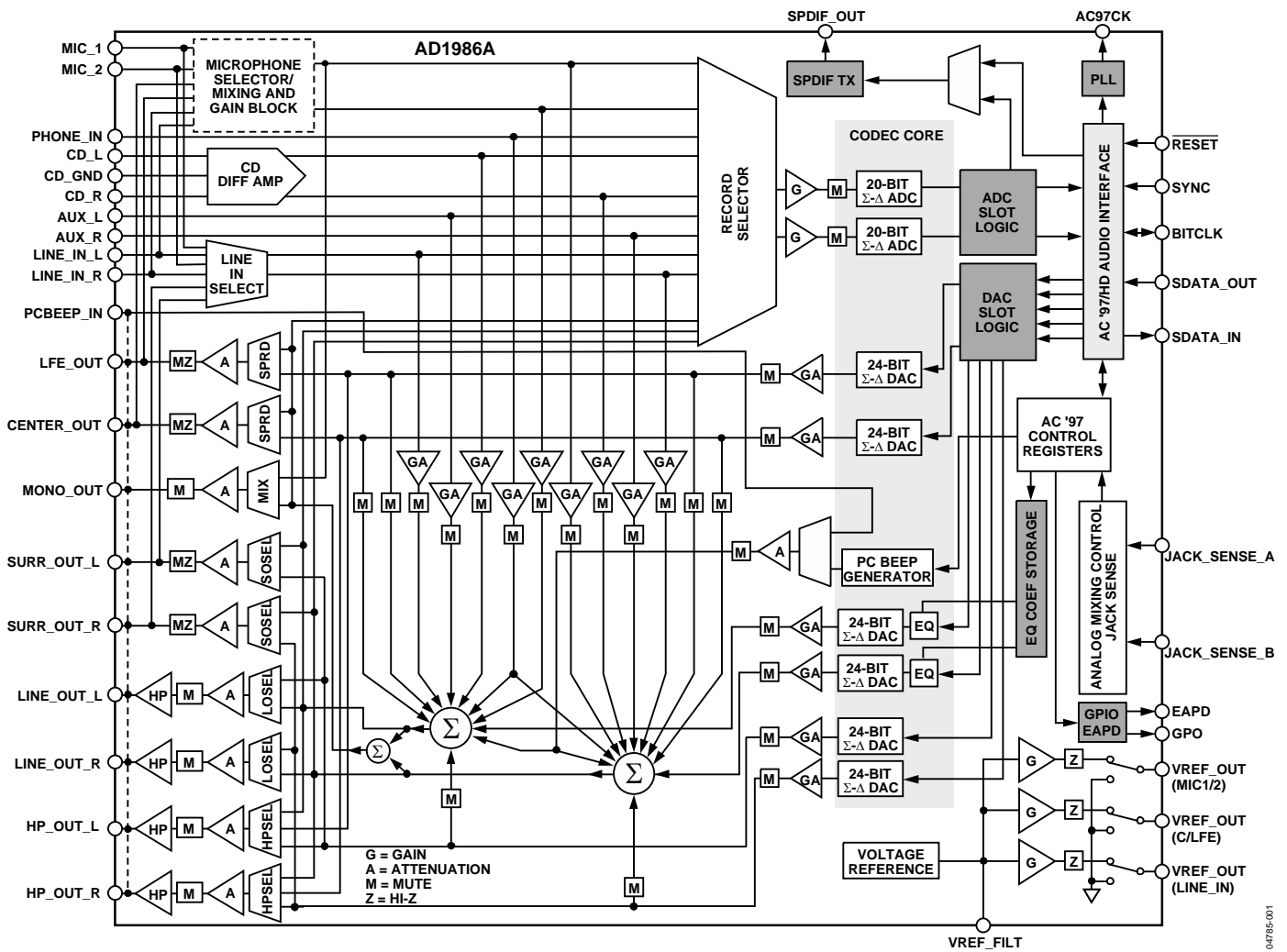

Figure 1.

## SPECIFICATIONS

Test conditions, unless otherwise noted.

**Table 1.**

Parameter	Typ	Unit
Temperature	25	°C
Digital Supply (DV <sub>DD</sub> )	3.3 ± 10%	V
Analog Supply (AV <sub>DD</sub> )	5.0 ± 10%	V
Sample Rate (F <sub>s</sub> )	48	kHz
Input Signal	1.0	kHz
Analog Output Pass Band	20 Hz–20 kHz	
V <sub>IH</sub>	2.0	V
V <sub>IL</sub>	0.8	V
V <sub>IH</sub>	2.4	V
V <sub>IL</sub>	0.6	V

### DAC Test Conditions

Calibrated  
 Output –3 dB Relative to Full Scale  
 10 kΩ Output Load: Line (Surround), Mono  
 32 Ω Output Load: Headphone  
 2 kΩ Output Load: Center, LFE

### ADC Test Conditions

Calibrated  
 0 dB PGA Gain  
 Input –3.0 dB Relative to Full Scale

**Table 2. Analog Input**

Input Voltage	Min	Typ	Max	Unit
MIC_1/2, LINE_IN, CD, AUX, PHONE_IN (No Preamp)		1		V <sub>rms</sub> <sup>1</sup>
C/LFE and SURROUND (When Used as Inputs)		2.83		V p-p
MIC_1/2, LINE_IN, C/LFE With 30 dB Preamp		0.032		V <sub>rms</sub>
		0.089		V p-p
MIC_1/2, LINE_IN, C/LFE With 20 dB Preamp		0.1		V <sub>rms</sub>
		0.283		V p-p
MIC_1/2, LINE_IN, C/LFE With 10 dB Preamp		0.316		V <sub>rms</sub>
		0.894		V p-p
Input Impedance <sup>2</sup>		20		kΩ
Input Capacitance <sup>2</sup>		5	7.5	pF

<sup>1</sup> RMS values assume sine wave input.

<sup>2</sup> Guaranteed by design, not production tested.

**Table 3. Master Volume**

Parameter	Min	Typ	Max	Unit
Step Size (LINE_OUT, HP Out, Mono Out, SURROUND, CENTER, LFE)		–1.5		dB
Output Attenuation Range (0 dB to –46.5 dB)		–46.5		dB
Mute Attenuation of 0 dB Fundamental <sup>2</sup>	–80			dB

**Table 4. Programmable Gain Amplifier—ADC**

Parameter	Min	Typ	Max	Unit
Step Size		1.5		dB
PGA Gain Range Span (0 dB to 22.5 dB)		22.5		dB

# AD1986A

**Table 5. Analog Mixer—Input Gain/Amplifiers/Attenuators**

Parameter	Min	Typ	Max	Unit
Signal-to-Noise Ratio (SNR)				
CD to LINE_OUT		90		dB
LINE, AUX, PHONE to LINE_OUT <sup>1</sup>		88		dB
MIC_1 or MIC_2 to LINE_OUT <sup>1</sup>		80		dB
Step Size: All Mixer Inputs (Except PC Beep)		-1.5		dB
Step Size: PC Beep		-3.0		dB
Input Gain/Attenuation Range: All Mixer Inputs (+12 dB to -34.5 dB)		-46.5		dB

<sup>1</sup> Guaranteed by design, not production tested.

**Table 6. Digital Decimation and Interpolation Filters<sup>1</sup>**

Parameter	Min	Typ	Max	Unit
Pass Band	0		$0.4 \times F_s$	Hz
Pass-Band Ripple			$\pm 0.09$	dB
Transition Band	$0.4 \times F_s$		$0.6 \times F_s$	Hz
Stop Band	$0.6 \times F_s$		$\infty$	Hz
Stop-Band Rejection	-74			dB
Group Delay		$16/F_s$		S
Group Delay Variation Over Pass Band		0		$\mu$ s

**Table 7. Analog-to-Digital Converters**

Parameter	Min	Typ	Max	Unit
Resolution		20		Bits
Total Harmonic Distortion (THD)		-95		dB
Dynamic Range (-60 dB Input, THD + N Referenced to Full Scale, A-Weighted)		-85		dB
Crosstalk: Line Inputs (Input L, Ground R, Read R; Input R, Ground L, Read L)		-80		dB
Crosstalk: LINE_IN to Other Inputs		-100	-80	dB
Gain Error (Full-Scale Span Relative to Nominal Input Voltage)		$\pm 10$		%
Interchannel Gain Mismatch (Difference of Gain Errors)			$\pm 0.5$	dB
ADC Offset Error			$\pm 5$	mV

Table 8. Digital-to-Analog Converters

Parameter	Min	Typ	Max	Unit
Resolution		20/24		Bits
Total Harmonic Distortion (LINE_OUT Drive)		-92		dB
Total Harmonic Distortion (HP_OUT)		-75		dB
Dynamic Range (-60 dB Input, THD + N Referenced to Full-Scale, A-Weighted)		91		dB
Gain Error (Full-Scale Span Relative to Nominal Input Voltage)		±10		%
Interchannel Gain Mismatch (Difference of Gain Errors)			±0.7	dB
DAC Crosstalk <sup>1</sup> (Input L, Zero R, Read R_OUT; Input R, Zero L, Read L_OUT)			-80	dB

<sup>1</sup> Guaranteed by design, not production tested.

Table 9. Analog Output

Parameter	Min	Typ	Max	Unit
FULL-SCALE OUTPUT VOLTAGE: SURROUND, CENTER/LFE, MONO_OUT		1		VRMS
Output Impedance <sup>1</sup>		2.83		V p-p
External Load Impedance <sup>1</sup>	10	300		Ω
Output Capacitance <sup>1</sup>		15		pF
External Load Capacitance			1,000	pF
FULL-SCALE OUTPUT VOLTAGE: HP_OUT, LINE_OUT		1		VRMS
Output Impedance <sup>1</sup>		2.83		V p-p
External Load Impedance <sup>1</sup>	32		1	Ω
Output Capacitance <sup>1</sup>		15		pF
External Load Capacitance <sup>1</sup>			1,000	pF
VREF_FILT	2.050	2.250	2.450	V
VREF_OUT(MIC, C/LFE, LIN) (xVREF [2:0] = 001)		2.250		V
(xVREF [2:0] = 100, A <sub>VDD</sub> = 5.0 V)		3.700		V
(xVREF [2:0] = 010)		0.0		V
Current Drive			5	mA
Mute Click (Muted Output, Unmuted Midscale DAC Output)		±5		mV

<sup>1</sup> Guaranteed by design, not production tested.

Table 10. Static Digital Specifications—AC '97

Parameter	Min	Typ	Max	Unit
High Level Input Voltage (V <sub>IH</sub> ), Digital Inputs	0.65 × DV <sub>DD</sub>			V
Low Level Input Voltage (V <sub>IL</sub> )			0.35 × DV <sub>DD</sub>	V
High Level Output Voltage (V <sub>OH</sub> ), I <sub>OH</sub> = 2 mA	0.90 × DV <sub>DD</sub>			V
Low Level Output Voltage (V <sub>OL</sub> ), I <sub>OL</sub> = 2 mA			0.10 × DV <sub>DD</sub>	V
Input Leakage Current	-10	10		μA
Output Leakage Current	-10	10		μA
Input/Output Pin Capacitance			7.5	pF

# AD1986A

**Table 11. Power Supply (Quiescent State)**

Parameter	Min	Typ	Max	Unit
Power Supply Range—Analog ( $AV_{DD} \pm 10\%$ )	4.5		5.5	V
Power Supply Range—Digital ( $DV_{DD} \pm 10\%$ )	2.97		3.63	V
Power Dissipation—Analog ( $AV_{DD}$ )/Digital ( $DV_{DD}$ )		365/171.6		mW
Analog Supply Current—Analog ( $AV_{DD}$ )		62.0		mA
Digital Supply Current—Digital ( $DV_{DD}$ )		53.2		mA
Power Supply Rejection (100 mV p-p Signal @ 1 kHz)		40		dB

**Table 12. Power-Down States—AC '97 (Quiescent State)**

Parameter	Set Bits	$AV_{DD}$ Typ	$DV_{DD}$ Typ	Unit
ADC	PR0	53.0	45.7	mA
FRONT DAC	PR1	53.7	47.7	mA
CENTER DAC	PRI	62.0	53.2	mA
SURROUND DAC	PRJ	53.5	47.1	mA
LFE DAC	PRK	62.0	52.8	mA
ADC + ALL DACs	PR1, PR0, PRI, PRJ, PRK	27.0	14.5	mA
Mixer	PR2	36.6	53.2	mA
ADC + Mixer	PR2, PR0	27.6	45.7	mA
ALL DACs + Mixer	PR2, PR1, PRI, PRJ, PRK	12.6	33.0	mA
ADC + ALL DACs + Mixer	PR2, PR1, PR0, PRI, PRJ, PRK	2.4	14.5	mA
Standby	PR5, PR4, PR3, PR2, PR1(IJK), PR0	0.0	0.05	mA
Headphone Standby	PR6	55.0	53.2	mA
LINE_OUT HP Standby	LOHPEN = 0	62.0	53.2	mA

**Table 13. Clock Specifications**

Parameter	Min	Typ	Max	Unit
Input Clock Frequency (Reference Clock Mode)		14.31818 48.000		MHz MHz
Recommended Clock Duty Cycle	40	50	60	%



## ABSOLUTE MAXIMUM RATINGS

Table 14.

Power Supply	Min	Max	Unit
Digital (DV <sub>DD</sub> )	-0.3	+3.6	V
Analog (AV <sub>DD</sub> )	-0.3	+6.0	V
Input Current (Except Supply Pins)		±10.0	mA
Analog Input Voltage (Signal Pins)	-0.3	AV <sub>DD</sub> + 0.3	V
Digital Input Voltage (Signal Pins)	-0.3	DV <sub>DD</sub> + 0.3	V
Ambient Temperature (Operating)			°C
Commercial	0	+70	
Industrial	-40	+85	
Storage Temperature	-65	+150	°C

Stresses greater than those listed under Absolute Maximum Ratings can cause permanent damage to the device. This is a stress rating only, functional operation of the device at these or any other conditions above those indicated in the operational section of this specification is not implied. Exposure to absolute maximum rating conditions for extended periods can affect device reliability.

### ESD CAUTION

ESD (electrostatic discharge) sensitive device. Electrostatic charges as high as 4000 V readily accumulate on the human body and test equipment and can discharge without detection. Although this product features proprietary ESD protection circuitry, permanent damage may occur on devices subjected to high energy electrostatic discharges. Therefore, proper ESD precautions are recommended to avoid performance degradation or loss of functionality.



### ENVIRONMENTAL CONDITIONS

Ambient Temperature Rating

$$T_{AMB} = T_{CASE} - (PD \times \theta_{CA})$$

$T_{CASE}$  = case temperature in °C

PD = power dissipation in W

$\theta_{CA}$  = thermal resistance (case-to-ambient)

$\theta_{JA}$  = thermal resistance (junction-to-ambient)

$\theta_{JC}$  = thermal resistance (junction-to-case)

Table 15. Thermal Resistance

Package	$\theta_{JA}$	$\theta_{JC}$	$\theta_{CA}$
LQFP	48°C/W	17°C/W	31°C/W
LFCSF	47°C/W	15°C/W	32°C/W

# AD1986A

## PIN CONFIGURATION AND FUNCTION DESCRIPTION

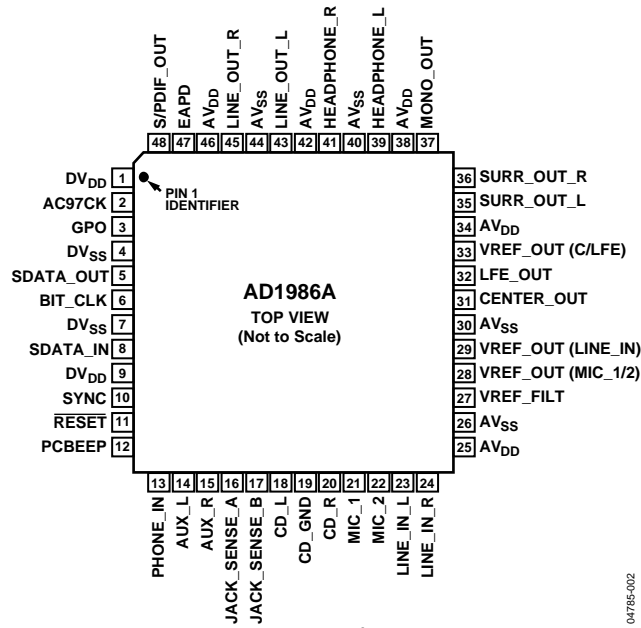

Figure 2. Pin Configuration

Table 16. Pin Function Descriptions

Mnemonic	Pin Number	Input/Output	Description
AC '97CK	2	I	External Clock In (14.31818 MHz) for AC '97 Operation. Clock or DVSS must be stable before reset deasserts.
SDATA_OUT	5	I	Link Serial Data Output. Input Stream.
BIT_CLK	6	I/O	Link Bit Clock, 12.288 MHz Serial Data Clock Output for AC '97, 24 MHz Input for HD Audio.
SDATA_IN	8	I/O	Link Serial Data Input. Output stream.
SYNC	10	I	Link Frame Sync.
RESET	11	I	Link Reset, Master Hardware Reset.

Table 17. Digital Input/Output

Mnemonic	Pin Number	Input/Output	Description
S/PDIF_OUT	48	O	S/PDIF Output.
EAPD	47	O	External Amplifier Power-Down Output. In HD audio mode this is part of LINE_OUT widget.
GPO	3	O	General-Purpose Output Pin. A digital signal that can be used to control external circuitry.

Table 18. Jack Sense

Mnemonic	Pin Number	Input/Output	Description
JACK_SENSE_A	16	I	JackSense 0–3 Input.
JACK_SENSE_B	17	I	Jack Sense 4–7 Input.

Table 19. Analog Input/Output

Mnemonic	Pin Number	Input/Output	Description
PCBEEP	12	I	Analog PC Beep Input. Routed to all output capable pins when RESET is asserted.
PHONE_IN	13	I	Mono Line Level Input.
AUX_L	14	I	Auxiliary Left Channel Input.
AUX_R	15	I	Auxiliary Right Channel Input.
CD_L	18	I	CD-Audio-Left Channel.
CD_GND	19	I	CD-Audio-Analog-Ground-Reference (for Differential CD Input).
CD_R	20	I	CD-Audio-Right Channel.
MIC_1	21	I	Microphone 1 or Line-In-Left Input (See LISEL Bits in Register 0x76).
MIC_2	22	I	Microphone 2 or Line-In-Right Input (See LISEL Bits in Register 0x76).
LINE_IN_L	23	I	Line-In-Left Channel or Microphone 1 Input (See OMS Bits in Register 0x74).
LINE_IN_R	24	I	Line-In-Right Channel or Microphone 2 Input (See OMS Bits in Register 0x74).
CENTER_OUT	31	I/O	Center-Channel Output or Microphone 1 Input (See OMS Bits in Register 0x74).
LFE_OUT	32	I/O	Low-Frequency-Enhanced Output or Microphone 2 Input (See OMS Bits in Register 0x74).
HEADPHONE_L	39	O	Headphone-Out-Left Channel (See HPSEL Bits in Register 0x76).
HEADPHONE_R	41	O	Headphone-Out-Right Channel (See HPSEL Bits in Register 0x76).
LINE_OUT_L	43	O	Line-Out (Front)—Left Channel (See LOSEL Bit in Register 0x76) (HP Drive-Capable).
LINE_OUT_R	45	O	Line-Out (Front)—Right Channel (See LOSEL Bit in Register 0x76) (HP Drive-Capable).
MONO_OUT	37	O	Mono Output to Telephony Subsystem Speakerphone.
SURR_OUT_L	35	I/O	Surround-Left Channel Output or Line-In-Left Input (See LISEL and SOSEL Bits in Register 0x76).
SURR_OUT_R	36	I/O	Surround-Right Channel Output or Line-In-Right Input (See LISEL and SOSEL Bits in Register 0x76).

Table 20. Filter/Reference

Mnemonic	Pin Number	Input/Output	Description
VREF_FILT	27	O	Voltage Reference Filter.
VREF_OUT (MIC)	28	O	Programmable Voltage Reference Output (Intended for MIC Bias on the MIC_1/2 Channels).
VREF_OUT (LINE_IN)	29	O	Programmable Voltage Reference Output (Intended for MIC Bias on the LINE_IN Channels).
VREF_OUT (C/LFE)	33	O	Programmable Voltage Reference Output (Intended for MIC Bias on the C/LFE Channels).

Table 21. Power and Ground

Mnemonic	Pin Number	Input/Output	Description
DV <sub>DD</sub>	1, 9	N/A	Digital Supply Voltage (3.3 V).
DV <sub>SS</sub>	4, 7	N/A	Digital Supply Return (Ground).
AV <sub>DD</sub>	25, 34, 38, 42, 46	N/A	Analog Supply Voltage (5.0 V). AV <sub>DD</sub> supplies should be well filtered because supply noise will degrade performance.
AV <sub>SS</sub>	26, 30, 40, 44	N/A	Analog Supply Return (Ground).

## AC'97 REGISTERS

Table 22. Register Map

Reg	Name	D15	D14	D13	D12	D11	D10	D9	D8	D7	D6	D5	D4	D3	D2	D1	D0	Default
0x00	Reset	x	SE4	SE3	SE2	SE1	SE0	ID9	ID8	ID7	ID6	ID5	ID4	ID3	ID2	ID1	ID0	0x0290
0x02	Master Volume	LM	x	x	LV4	LV3	LV2	LV1	LV0	RM	x	x	RV4	RV3	RV2	RV1	RV0	0x8080
0x04	Headphones Volume	LM	x	x	LV4	LV3	LV2	LV1	LV0	RM	x	x	RV4	RV3	RV2	RV1	RV0	0x8080
0x06	Mono Volume	M	x	x	x	x	x	x	x	x	x	x	V4	V2	V2	V1	V0	0x8000
0x0A	PC Beep	M	A/DS	x	F7	F6	F5	F4	F3	F2	F1	F0	V3	V2	V1	V0	x	0x8000
0x0C	Phone Volume	M	x	x	x	x	x	x	x	x	x	x	V4	V3	V2	V1	V0	0x8008
0x0E	Microphone Volume	LM	x	x	LV4	LV3	LV2	LV1	LV0	RM	M20	x	RV4	RV3	RV2	RV1	RV0	0x8888
0x10	Line In Volume	LM	x	x	LV4	LV3	LV2	LV1	LV0	RM	x	x	RV4	RV3	RV2	RV1	RV0	0x8888
0x12	CD Volume	LM	x	x	LV4	LV3	LV2	LV1	LV0	RM	x	x	RV4	RV3	RV2	RV1	RV0	0x8888
0x16	AUX Volume	LM	x	x	LV4	LV3	LV2	LV1	LV0	RM	x	x	RV4	RV3	RV2	RV1	RV0	0x8888
0x18	Front DAC Volume	LM	x	x	LV4	LV3	LV2	LV1	LV0	RM	x	x	RV4	RV3	RV2	RV1	RV0	0x8888
0x1A	ADC Select	x	x	x	x	x	LS2	LS1	LS0	x	x	x	x	x	RS2	RS1	RS0	0x0000
0x1C	ADC Volume	LM	x	x	x	LV3	LV2	LV1	LV0	RM	x	x	x	RV3	RV2	RV1	RV0	0x8080
0x20	General Purpose	x	x	x	x	DRSS1	DRSS0	MIX	MS	LPBK	x	x	x	x	x	x	x	0x0000
0x24	Audio Int. and Paging	I4	I3	I2	I1	I0	x	x	x	x	x	x	x	PG3	PG2	PG1	PG0	0xxx00
0x26	Power-Down Ctrl/Stat	EAPD	PR6	PR5	PR4	PR3	PR2	PR1	PR0	x	x	x	x	REF	ANL	DAC	ADC	0x000x
0x28	Ext'd Audio ID	ID1 <sup>1</sup>	ID0	x	x	REV1	REV0	AMAP	LDAC	SDAC	CDAC	DSA1	DSA0	x	SPDF	DRA	VRA	0x0BC7
0x2A	Ext'd Audio Stat/Ctrl	x	x	PRK	PRJ	PRI	SPCV	x	LDAC	SDAC	CDAC	SPSA1	SPSA0	x	SPDIF	DRA	VRA	0x0xx0
0x2C	Front DAC PCM Rate	R15	R14	R13	R12	R11	R10	R09	R08	R07	R06	R05	R04	R03	R02	R01	R00	0xBB80
0x2E	Surr. DAC PCM Rate	R15	R14	R13	R12	R11	R10	R09	R08	R07	R06	R05	R04	R03	R02	R01	R00	0xBB80
0x30	C/LFE DAC PCM Rate	R15	R14	R13	R12	R11	R10	R09	R08	R07	R06	R05	R04	R03	R02	R01	R00	0xBB80
0x32	ADC PCM Rate	R15	R14	R13	R12	R11	R10	R09	R08	R07	R06	R05	R04	R03	R02	R01	R00	0xBB80
0x36	C/LFE DAC Volume	LFEM	x	x	LFE4	LFE3	LFE2	LFE1	LFE0	CNTM	x	x	CNT4	CNT3	CNT2	CNT1	CNT0	0x8888
0x38	Surround DAC Volume	LM	x	x	LV4	LV3	LV2	LV1	LV0	RM	x	x	RV4	RV3	RV2	RV1	RV0	0x8888
0x3A	SPDIF Control	V	VCFG	SPSR	x	L	CC6	CC5	CC4	CC3	CC2	CC1	CC0	PRE	COPY	/AUDIO	PRO	0x2000
0x60	EQ Control	EQM	x	x	x	x	x	x	x	SYM	CHS	BCA5	BCA4	BCA3	BCA2	BCA1	BCA0	0x8080
0x62	EQ Data	CFD15	CFD14	CFD13	CFD12	CFD11	CFD10	CFD9	CFD8	CFD7	CFD6	CFD5	CFD4	CFD3	CFD2	CFD1	CFD0	0xxxxx
0x70	Misc. Control Bits 2	x	x	x	MVREF2	MVREF1	MVREF0	x	x	MMDIS	x	JSMAP	CVREF2	CVREF1	CVREF0	x	x	0x0000
0x72	Jack Sense	JS1 SPRD	JS1 DMX	JS0 DMX	JS MT2	JS MT1	JS MT0	JS1 EQB	JS0 EQB	x	x	JS1 MD	JS0 MD	JS1 ST	JS0 ST	JS1 INT	JS0 INT	0x0000
0x74	Serial Configuration	SLOT16	REGM2	REGM1	REGM0	REGM3	OMS2	OMS1	OMS0	SPOVR	LBKS1	LBKS0	INTS	CSWP	SPAL	SPDZ	SPLNK	0x1001
0x76	Misc. Control Bits 1	DACZ	AC97NC <sup>2</sup>	MSPLT	SODIS <sup>3</sup>	CLDIS	x	DMIX1	DMIX0	SPRD	2CMIC	SOSEL	SRU	LISEL1	LISEL0	MBG1	MBG0	0x6010
0x78	Advanced Jack Sense	JS7ST	JS7INT	JS6ST	JS6INT	JS5ST	JS5INT	JS4ST	JS4INT	JS4-7H	x	JS3MD	JS2MD	JS3ST	JS2ST	JS3INT	JS2INT	0xxxxx
0x7A	Misc. Control Bits 3	JSINVB	HPSEL1	HPSEL0	LOSEL	JSINVA	LVREF2	LVREF1	LVREF0	x	x	x	LOHPEN	GPO	MMIX	x	x	0x0000
0x7C	Vendor ID1	F7	F6	F5	F4	F3	F2	F1	F0	S7	S6	S5	S4	S3	S2	S1	S0	0x4144
0x7E	Vendor ID2	T7	T6	T5	T4	T3	T2	T1	T0	REV7	REV6	REV5	REV4	REV3	REV2	REV1	REV0	0x5378
0x601	Codec Class/Rev	x	x	x	CL4	CL3	CL2	CL1	CL0	RV7	RV6	RV5	RV4	RV3	RV2	RV1	RV0	0x0002
0x621	PCI SVID	PVI15	PVI14	PVI13	PVI12	PVI11	PVI10	PVI9	PVI8	PVI7	PVI6	PVI5	PVI4	PVI3	PVI2	PVI1	PVI0	0xFFFF
0x641	PCI SID	PI15	PI14	PI13	PI12	PI11	PI10	PI9	PI8	PI7	PI6	PI5	PI4	PI3	PI2	PI1	PI0	0xFFFF

Reg	Name	D15	D14	D13	D12	D11	D10	D9	D8	D7	D6	D5	D4	D3	D2	D1	D0	Default
0x661	Function Select	x	x	x	x	x	x	x	x	x	x	x	FC3	FC2	FC1	FC0	T/R	0x0000
0x681	Function Information	G4	G3	G2	G1	G0	INV	DL4	DL3	DL2	DL1	DL0	IV	x	x	x	FIP	0xXxxx
0x6A1	Sense Register	ST2	ST1	ST0	S4	S3	S2	S1	S0	OR1	OR0	SR5	SR4	SR3	SR2	SR1	SR0	0xXxxx

<sup>1</sup> Codec is always master, ID bits are read-only 0 (zeros).

<sup>2</sup> Bits for the AD198x are backward-compatible only, AC97NC and MSPLT are read-only 1 (ones).

<sup>3</sup> SODIS/SOSEL were LODIS/LOSEL in the AD1985. Most AD1985 configurations swap LINE\_OUT and SURROUND pins; these bits really operate as SO not LO.

# AD1986A

## HD AUDIO WIDGETS

Table 23. Root Node

NID	Name	TID	Type	Description
0x00	Root	N/A	Root	Device identification.

Table 24. Function Group Node

NID	Name	TID	Type	Description
0x01	Function	N/A	Function	Designates this device as an audio codec.

Table 25. ADI Specific Verb Support

Verb	G/S	VID	Payload		Response (32 Bits)	Description
			Description	Bit		
SDI Select	Get	0xF04	N/A (0)		N/A (0)	The AD1986A has only a single SDI line, thus set SDI verbs are ignored and get SDI verbs always return a 0.
	Set	0x704x	N/A (0)	8	N/A (0)	
Processing Coefficient	Get	C--0x	N/A (0)		ADI-Specific Function Setting	Get/set the vendor specific function at the below coefficient index address. Address is an 8-bit value and does not auto-increment.
	Set	4--x	ADI-specific function control	16	N/A (0)	
Coefficient Index	Get	D--0x	N/A (0)		ADI Function Index	Get/set the index of the vendor-specific function. The index does not auto-increment when writing the function (processing coefficient) command.
	Set	5--0x	ADI function index	8	N/A (0)	
Processing Index	Get	0xF03	N/A (0)		N/A (0)	No processing states are supported by this node. Set operations do nothing, Get operations always return a 0.
	Set	0x703	N/A (0)	8	N/A (0)	

Table 26. S/PDIF Audio Output

NID	Name	TID	Type	Description
0x02	S/PDIF Audio Output	0x0	Audio Output	Designates the codec S/PDIF digital stream interface. Selects between the HD audio I/F and the record ADC as sources.

Table 27. ADI Specific Verb Support

Verb	G/S	VID	Payload		Response (32 Bits)	Description
			Description	Bit		
SDI Select	Get	0xF04	N/A (0)		N/A (0)	The AD1986 has only a single SDI line, thus set SDI verbs are ignored and get SDI verbs always return a 0.
	Set	0x704	N/A (0)	8	N/A (0)	

Table 28. Front DAC Audio Output

NID	Name	TID	Type	Description
0x03	Front DAC Audio Output	0x0	Audio Output	Designates the front channel DACs.

Table 29. ADI Specific Verb Support

Verb	G/S	VID	Payload		Response (32 Bits)	Description															
			Description	Bit																	
SDI Select	Get	0xF04	N/A (0)		N/A (0)	The AD1986A has only a single SDI line, thus set SDI verbs are ignored and get SDI verbs always return a 0.															
	Set	0x704	N/A (0)	8	N/A (0)																
Processing Coefficient	Get	C--0x	N/A (0)		Coefficient	Get/set the processing coefficient at the current coefficient index. Index can be set by the "set coefficient index" verb. The coefficient indexes and data are identical to the AC' 97 Registers 0x60 and 0x62 definitions (see the EQ Control Register (Register 0X60) and EQ Data Register (Register 0X62) sections). Note that the AD1986A does not automatically increment the coefficient index. The index must be written for each coefficient that is to be loaded or read.															
	Set	4--x	Coefficient	16	N/A (0)																
Coefficient Index	Get	D--0x	N/A (0)		Coefficient Index	Get/set the processing coefficient index for the get/set Processing Coefficient verb. The coefficient indexes and data are identical to the AC' 97 register 0x60 and 0x62 definitions. (see the EQ Control Register (Register 0X60) and EQ Data Register (Register 0X62) sections). Note that the AD1986A does not automatically increment the coefficient index. The index must be written for each coefficient that is to be loaded or read.															
	Set	5--0x	Coefficient Index	8	N/A (0)																
Processing State	Get	0xF03	N/A (0)		Processing State	Processing states supported by the AD1986 Digital EQ:															
						<table border="1"> <thead> <tr> <th>Value</th> <th>Processing (EQM Bit [Inversed])</th> <th>Symmetry (SYM Bit)</th> </tr> </thead> <tbody> <tr> <td>0x00</td> <td>Off</td> <td>On</td> </tr> <tr> <td>0x01</td> <td>Benign</td> <td>On</td> </tr> <tr> <td>0x02</td> <td>Benign</td> <td>On</td> </tr> <tr> <td>0x80</td> <td>Off</td> <td>Off</td> </tr> <tr> <td>0x81</td> <td>Benign</td> <td>Off</td> </tr> <tr> <td>0x82</td> <td>Benign</td> <td>Off</td> </tr> </tbody> </table>	Value	Processing (EQM Bit [Inversed])	Symmetry (SYM Bit)	0x00	Off	On	0x01	Benign	On	0x02	Benign	On	0x80	Off	Off
Value	Processing (EQM Bit [Inversed])	Symmetry (SYM Bit)																			
0x00	Off	On																			
0x01	Benign	On																			
0x02	Benign	On																			
0x80	Off	Off																			
0x81	Benign	Off																			
0x82	Benign	Off																			
	Set	0x703	Processing State	8	N/A (0)	Note that the AD1986A considers states on and benign as both benign. If the on state is set, the AD1986 will set and return the benign state. States 0x00 or 0x80 must be set when loading coefficients. Setting state 0x80 will load coefficients with SYM off. Default state 0x00 is SYM on. When symmetry is on, only 1/2 of the coefficients (one channel) need to be loaded.															

Table 30. Surround DAC Audio Output

NID	Name	TID	Type	Description
0x04	Surround DAC Audio Output	0x0	Audio Output	Designates the surround channel DACs.

Table 31. ADI Specific Verb Support

Verb	G/S	VID	Payload		Response (32 Bits)	Description
			Description	Bit		
SDI Select	Get	0xF04	N/A (0)		N/A (0)	The AD1986 has a only single SDI line, thus set SDI verbs are ignored and get SDI verbs always return a 0.
	Set	0x704x	N/A (0)	8	N/A (0)	

# AD1986A

**Table 32. Center/LFE DAC Audio Output**

NID	Name	TID	Type	Description
0x05	Center/LFE DAC Audio Output	0x0	Audio Output	Designates the surround channel DACs.

**Table 33. Record ADC Audio Input**

NID	Name	TID	Type	Description
0x06	Record ADC Audio Input	0x1	Audio Input	Designates the record channel ADCs.

**Table 34. Analog Mixer**

NID	Name	TID	Type	Description
0x07	Analog Mixer	0x2	Audio Mixer	Mixes analog input signals into line out audio.

**Table 35. Mono Mixer**

NID	Name	TID	Type	Description
0x08	Mono Mixer	0x2	Audio Mixer	Mixes the left/right channels from the analog mixer into a mono signal.

**Table 36. Downmix**

NID	Name	TID	Type	Description
0x09	Surround to Stereo Down Mix	0x2	Audio Mixer	Mixes 5.1 stereo to 4.0 or 2.0 on front channels.

**Table 37. ADI Specific Verb Support**

Verb	G/S	VID	Payload		Response (32 Bits)	Description
			Description	Bits		
Amplifier Gain/Mute	Get	B--0x	Amp/Index	16	Amp settings	This widget contains mute bits for the output and only one input. Surround DAC (input amp Index 0), has a mute bit. The CLFE DAC input (input amp Index 1) does not have a mute control. Writing the CLFE DAC input mute will have no effect and will always return a 0 when read.
	Set	3--0x	Amp Set Payload	16	N/A (0)	

**Table 38. Headphone Selector**

NID	Name	TID	Type	Description
0x0A	Headphone Selector	0x3	Audio Selector	Chooses the HP source.

**Table 39. Line Out Selector**

NID	Name	TID	Type	Description
0x0B	Line Out Selector	0x3	Audio Selector	Chooses the line out source.

**Table 40. Surround Selector**

NID	Name	TID	Type	Description
0x0C	Surround Selector	0x3	Audio Selector	Chooses the surround source.

**Table 41. Center/LFE Selector**

NID	Name	TID	Type	Description
0x0D	Center/LFE Selector	0x3	Audio Selector	Chooses the center/LFE source.

**Table 42. Mono Out Selector**

NID	Name	TID	Type	Description
0x0E	Mono Out Selector	0x3	Audio Selector	Chooses the mono out source.



Table 43. Microphone Selector

NID	Name	TID	Type	Description
0x0F	Microphone Selector	0x3	Audio Selector	Chooses the microphone inputs between the MIC_1/2 and C/LFE pins. Contains the microphone gain boost amplifier.

Table 44. Line In Selector

NID	Name	TID	Type	Description
0x10	Line In Selector	0x3	Audio Selector	Chooses the line in inputs between the line in, surround and MIC_1/2 pins.

Table 45. MIC\_1/2 Swap

NID	Name	TID	Type	Description
0x11	MIC_1/2 Swap	0x3	Audio Selector	Swaps the left/right association of MIC_1/2 on the input pins only. Allows up mix, spreading one microphone to both left and right output channels.

Table 46. ADI Specific Verb Support

Verb	G/S	VID	Payload		Response (32 bits)	Description
			Description	Blt		
Processing Coefficient	Get	C--0x	N/A (0)		N/A (0)	Not supported. Writes have no effect, reads always return a 0.
	Set	4--0x	N/A (0)	16	N/A (0)	
Coefficient Index	Get	D--0x	N/A (0)		N/A (0)	Not supported. Writes have no effect, reads always return a 0.
	Set	5--0x	N/A (0)	8	N/A (0)	
Processing State	Get	0xF03	N/A (0)		Processing State	Controls the up-mix function of the MIC_1/2 swap widget. Up-Mix will spread the selected left channel (see the left/right swap feature of the enable EAPD/BTL verb description) to both the left and right channel outputs of this stereo widget.
	0x00	Off	Off			
	0x01	Benign	On			
	0x02	Benign	On			
	Set	0x703	Processing State	8	N/A (0)	Note that the AD1986 considers both on and benign states as benign. If the on state is set, the AD1986 will set and return the benign state.

Table 47. Record Selector

NID	Name	TID	Type	Description
0x12	Record Selector	0x3	Audio Selector	Chooses the analog source to the record ADCs.

Table 48. Microphone MixAmp

NID	Name	TID	Type	Description
0x13	Microphone MixAmp	0x3	Audio Selector	The microphone amplifier input to the analog mixer.

Table 49. Phone MixAmp

NID	Name	TID	Type	Description
0x14	Phone MixAmp	0x3	Audio Selector	The phone amplifier input to the analog mixer.

Table 50. CD MixAmp

NID	Name	TID	Type	Description
0x15	CD MixAmp	0x3	Audio Selector	The CD amplifier input to the analog mixer.

# AD1986A

Table 51. Aux MixAmp

NID	Name	TID	Type	Description
0x16h	Aux MixAmp	0x3h	Audio Selector	The auxiliary input amplifier to the analog mixer.

Table 52. Line In MixAmp

NID	Name	TID	Type	Description
0x17	Line In MixAmp	0x3	Audio Selector	The line in amplifier input to the analog mixer.

Table 53. PC Beep Selector

NID	Name	TID	Type	Description
0x18	PC Beep Selector	0x3	Audio Selector	The digital/analog PC beep selector and amplifier input to the analog mixer.

Table 54. Digital PC Beep

NID	Name	TID	Type	Description
0x19	Digital PC Beep	0x7	Digital Beep	Digital PC beep generator.

Table 55. HP Out

NID	Name	TID	Type	Description
0x1A	HP Out	0x4	Pin Complex	HP_OUT pin drivers. Contains the output amplifier for HP gain control. Supports headphone drive function. See the pin widget control verb descriptions.

Table 56. Line Out

NID	Name	TID	Type	Description
0x1B	Line Out	0x4	Pin Complex	LINE (FRONT)_OUT pin drivers. Contains the output amplifier for line (front) gain control. Supports headphone drive function. Supports the EAPD (external amp power-down) function pin.

Table 57. Surround Out

NID	Name	TID	Type	Description
0x1C	Surround Out	0x4	Pin Complex	SURROUND pin drivers. Contains the output amplifier for surround gain control. Supports multitasking as either the surround outputs or can be configured as the LINE_IN inputs.

Table 58. C/LFE Out

NID	Name	TID	Type	Description
0x1D	C/LFE Out	0x4	Pin Complex	C/LFE pin drivers. Contains the output amplifier for C/LFE gain control. Supports the left/right channel swap function. Supports multitasking as either the C/LFE outputs or can be configured as the MIC1/2 inputs. Supports microphone bias (VREF_OUT).

Table 59. Mono Out

NID	Name	TID	Type	Description
0x1E	Mono Out	0x4	Pin Complex	MONO_OUT Pin driver. Contains the output amplifier for MONO_OUT gain control.

Table 60. MIC\_1/2 In

NID	Name	TID	Type	Description
0x1F	MIC_1/2 In	0x4	Pin Complex	MIC_1/2 IN pin driver. Can be configured as a microphone or Line_In input.

Table 61. Line In

NID	Name	TID	Type	Description
0x20	Line In	0x4	Pin Complex	LINE_IN pin driver. Can be configured as a Line_In or microphone input.

Table 62. Aux In

NID	Name	TID	Type	Description
0x21	Aux In	0x4	Pin Complex	AUX_IN pin driver. Line level auxiliary input.

Table 63. CD In

NID	Name	TID	Type	Description
0x22	CD In	0x4	Pin Complex	CD_IN pin driver. Differential, low noise, analog CD audio input.

Table 64. Phone In

NID	Name	TID	Type	Description
0x23	Phone In	0x4	Pin Complex	PHONE_IN pin driver. Mono line level input.

Table 65. PCBeep In

NID	Name	TID	Type	Description
0x24	PCBeep In	0x4	Pin Complex	PCBEEP_IN pin driver. Mono line level input. When the AD1986A is in reset, the signal on this pin is routed to all output capable pins. Used for BIOS POST beeps or messages.

Table 66. S/PDIF Out

NID	Name	TID	Type	Description
0x25	S/PDIF Out	0x4	Pin Complex	Digital S/PDIF output drivers. This pin can be hardware-enabled by connecting an external resistor to DVSS or by software control.

Table 67. Analog Power-Down

NID	Name	TID	Type	Description
0x26	Analog Power-Down	0x5	Power Widget	Controls power on analog mixer and associated amplifiers. This will control the power state of all widgets in its connection list.

Table 68. MIC/C/LFE Mixer

NID	Name	TID	Type	Description
0x27	MIC / C/LFE Mixer	0x2	Audio Mixer	Mixes the MIC1/2_IN and C/LFE input signals together to support simultaneous microphones on front and rear panels. Multiple microphones do not have individual gain controls.

Table 69. MIC/Line In Mixer

NID	Name	TID	Type	Description
0x28	MIC / Line In Mixer	0x2	Audio Mixer	Mixes the MIC1/2_IN and LINE_IN input signals together to support simultaneous microphones on front and rear panels. Multiple microphones do not have individual gain controls.

# AD1986A

**Table 70. C/LFE/Line In Mixer**

<b>NID</b>	<b>Name</b>	<b>TID</b>	<b>Type</b>	<b>Description</b>
0x29	C/LFE / Line In Mixer	0x2	Audio Mixer	Mixes the C/LFE and LINE_IN input signals together to support simultaneous microphones on front and rear panels. Multiple microphones do not have individual gain controls.

**Table 71. MIC/Line In/C/LFE Mixer**

<b>NID</b>	<b>Name</b>	<b>TID</b>	<b>Type</b>	<b>Description</b>
0x2A	MIC/Line In/C/LFE Mixer	0x2	Audio Mixer	Mixes the MIC1/2_IN, LINE_IN and C/LFE input signals to support simultaneous microphones on front and rear panels. Multiple microphones do not have individual gain controls.

**Table 72. MIC\_1/2 Mixer**

<b>NID</b>	<b>Name</b>	<b>TID</b>	<b>Type</b>	<b>Description</b>
0x2B	MIC_1/2 Mixer	0x2	Audio Mixer	Mixes the left and right channels of the selected microphone input into a mono stream. This signal drives both the left and right channels of the following circuitry. Used to mix two mono microphones on separate jacks. Left and right microphones can be programmed with separate gain boost (0 dB, 10 dB, 20 dB, or 30 dB), but do not have any other gain or mute controls.

## AC '97 REGISTER DETAILS

### RESET (REGISTER 0x00)

Writing any value to this register performs a register reset, which causes all registers to revert to their default values. The serial configuration (0x74) register will not reset the SLOT16, REGM [2:0], SPOVR, SPAL, SPDZ, and SPLNK. These bits are reset on a hard, hardware, or power-on reset. The REGM and serial configuration bits are reset only by an external hardware reset.

The AC '97, Revision 2.3, Page 1 registers codec class/rev (0x601), PCI SVID (0x621), PCI SID (0x641), function information (0x681—per supported function), and sense register ST [3:0] bits (0x6A1 D [15:13]—per supported function) are reset only on a power-on reset. To satisfy the AC '97, Revision 2.3 requirements, these registers/bits are sticky across all software and hardware resets.

Reading this register returns the ID code of the part and a code for the type of 3D stereo enhancement.

Reg	Name	D15	D14	D13	D12	D11	D10	D9	D8	D7	D6	D5	D4	D3	D2	D1	D0	Default
0x00	Reset	x	SE4	SE3	SE2	SE1	SE0	ID9	ID8	ID7	ID6	ID5	ID4	ID3	ID2	ID1	ID0	0x0290

Table 73.

Register	Function	AD1986A	ID [9:0]
ID [9:0] (RO) (Identify Capability)	The ID decodes the capabilities of the AD1986A based on the functions.		
	<b>Bit</b>	<b>Function</b>	
	ID0	Dedicated MIC PCM In channel	0
	ID1	Reserved (per AC '97, Revision 2.3)	0
	ID2	Bass and treble control	0
	ID3	Simulated stereo (mono to stereo)	0
	ID4	Headphone out support	1
	ID5	Loudness (bass boost) support	0
	ID6	18-bit DAC resolution	0
	ID7	20-bit DAC resolution	1
	ID8	18-bit ADC resolution	0
	ID9	20-bit ADC resolution	1
SE [4:0] (RO) (Stereo Enhancement)	The AD1986A does not provide hardware 3D stereo enhancement (all bits are zero).	Default: 0x00	
x	Reserved.	Default: 0	

### MASTER VOLUME (REGISTER 0x02)

This register controls the LINE\_OUT, SURROUND, and CENTER/LFE outputs' mute and volume controls in unison. Each volume sub-register contains five bits, generating 32 volume steps of  $-1.5$  dB each for a range of 0 dB to  $-46.5$  dB.

The headphone output (HP\_OUT) mute and volume are controlled separately by the headphones volume register (0x04). The mono output (MONO\_OUT) mute and volume are controlled separately by the mono volume register (0x06). To control the LINE\_OUT, SURROUND, and CENTER/LFE volumes separately, use the front DAC volume register (0x18) for LINE\_OUT; the surround DAC Volume register (0x38) for SURROUND; and the C/LFE DAC volume register (0x36) for CENTER/LFE.

Reg	Name	D15	D14	D13	D12	D11	D10	D9	D8	D7	D6	D5	D4	D3	D2	D1	D0	Default
0x02	Master Volume	LM	x	x	LV4	LV3	LV2	LV1	LV0	RM	x	x	RV4	RV3	RV2	RV1	RV0	0x8080

# AD1986A

Table 74.

Register	Function			
L/RV [4:0] (Left/Right Volume)	Left/right volume controls the left/right channel output gains from 0 dB to –46.5 dB. The least significant bit represents –1.5 dB.			
	L/RM	L/RV [4:0]	Function	Default
	0	0 0000	0 dB	Default
	0	0 1111	–22.5 dB attenuation	
	0	1 1111	–46.5 dB attenuation	
	1	x xxxx	Muted	
L/RM (Left/right mute)	Mutes the left/right channels independently.			Default: muted (0x1)
x	Reserved.			Default: 0

## HEADPHONE VOLUME (REGISTER 0x04)

This register controls the HP\_OUT mute and volume controls. Each volume subregister contains five bits, generating 32 volume steps of –1.5 dB each for a range of 0 dB to –46.5 dB.

Reg	Name	D15	D14	D13	D12	D11	D10	D9	D8	D7	D6	D5	D4	D3	D2	D1	D0	Default
0x04	Headphones Volume	LM	x	x	LV4	LV3	LV2	LV1	LV0	RM	x	x	RV4	RV3	RV2	RV1	RV0	0x8080

Table 75.

Register	Function			
L/RV [4:0] (Left/Right Volume)	Left/right volume controls the left/right channel output gains from 0 dB to –46.5 dB. The least significant bit represents –1.5 dB.			
	L/RM	L/RV [4:0]	Function	Default
	0	0 0000	0 dB	Default
	0	0 1111	–22.5 dB attenuation	
	0	1 1111	–46.5 dB attenuation	
	1	x xxxx	Muted	
L/RM (Left/Right Mute)	Mutes the left/right channels independently.			Default: muted (0x1)
x	Reserved.			Default: 0

## MONO VOLUME (REGISTER 0x06)

This register controls the MONO\_OUT mute and volume control. The volume register contains five bits, generating 32 volume steps of –1.5 dB each for a range of 0 dB to –46.5 dB.

Reg	Name	D15	D14	D13	D12	D11	D10	D9	D8	D7	D6	D5	D4	D3	D2	D1	D0	Default
0x06	Mono Volume	M	x	x	x	x	x	x	x	x	x	x	V4	V3	V2	V1	V0	0x8000

Table 76.

Register	Function			
V [4:0] (Volume)	Volume controls the output gain from 0 dB to –46.5 dB. The least significant bit represents –1.5 dB.			
	M	V [4:0]	Function	Default
	0	0 0000	0 dB	Default
	0	0 1111	–22.5 dB attenuation	
	0	1 1111	–46.5 dB attenuation	
	1	x xxxx	Muted	
M (Mute)	Mutes the output.			Default: muted (0x1)
x	Reserved.			Default: 0

## PC BEEP (REGISTER 0x0A)

This controls the level of the analog PC beep or the level and frequency of the digital PC beep. The volume register contains four bits, generating 16 volume steps of –3.0 dB each for a range of 0 dB to –45.0 dB. The tone frequency can be set between 47 Hz to 12,000 Hz or disabled.

Per Intel's BIOS writer's guide, the PC beep signal should play via headphone out, line out, and mono out paths. BIOS algorithms should unmute the PC beep register and the path to each output, and set the volume levels for playback.

When the AD1986A is in reset (the external RESET pin is low), the PCBEEP\_IN pin is connected internally to all of the device output pins (HEADPHONE L/R, LINE\_OUT L/R, MONO\_OUT, SURROUND L/R, and CENTER/LFE). There are no amplifiers or attenuators on this path and the external circuitry connected to this pin should anticipate the drive requirements for the multiple output sources. Headphones connected to output pins will substantially load the signal.

Reg	Name	D15	D14	D13	D12	D11	D10	D9	D8	D7	D6	D5	D4	D3	D2	D1	D0	Default
0x0A	PC Beep	M	A/DS	x	F7	F6	F5	F4	F3	F2	F1	F0	V3	V2	V1	V0	x	0x8000

Table 77.

Register	Function																
V [3:0] (Analog or Digital Volume)	Controls the gain into the output mixer from 0 dB to –45.0 dB. The least significant bit represents –3.0 dB. The gain default is 0 dB and muted.																
	<table border="1"> <thead> <tr> <th>M</th> <th>V3...V0</th> <th>Function</th> <th>Default</th> </tr> </thead> <tbody> <tr> <td>0</td> <td>0000</td> <td>0 dB</td> <td>Default</td> </tr> <tr> <td>0</td> <td>1111</td> <td>–45 dB attenuation</td> <td></td> </tr> <tr> <td>1</td> <td>xxxx</td> <td>Muted</td> <td></td> </tr> </tbody> </table>	M	V3...V0	Function	Default	0	0000	0 dB	Default	0	1111	–45 dB attenuation		1	xxxx	Muted	
M	V3...V0	Function	Default														
0	0000	0 dB	Default														
0	1111	–45 dB attenuation															
1	xxxx	Muted															
F [7:0] (PC Beep Frequency)	The result of dividing the 48 kHz clock by four times this number, allowing tones from 47 Hz to 12 kHz. A value of 0x00 disables internal PC beep generation. The digitally-generated signal is close to a square wave and is not intended to be a high quality signal.																
	<table border="1"> <thead> <tr> <th>F7...F0</th> <th>Function</th> <th>Default</th> </tr> </thead> <tbody> <tr> <td>0000</td> <td>Disabled</td> <td>Default</td> </tr> <tr> <td>0001</td> <td>12,000 Hz tone</td> <td></td> </tr> <tr> <td>1111</td> <td>47 Hz tone</td> <td></td> </tr> </tbody> </table>	F7...F0	Function	Default	0000	Disabled	Default	0001	12,000 Hz tone		1111	47 Hz tone					
F7...F0	Function	Default															
0000	Disabled	Default															
0001	12,000 Hz tone																
1111	47 Hz tone																
A/DS (PC Beep Source)	Selects either the digital PC beep generator (= 0) or analog PCBEEP pin (= 1). When the codec is in reset mode the analog PCBEEP pin is routed to the outputs via a high impedance path. Once out of reset, this bit must be programmed to a 1 to pass through any signals on the analog PCBEEP pin. Designers can choose not to connect the analog PCBEEP pin and use the digital PC beep generator solely.																
M (PC Beep Mute)	When this bit is set to 1, the PC beep signal (analog or digital) is muted.																
x	Reserved.																

## PHONE VOLUME (REGISTER 0x0C)

This register controls the PHONE\_IN mute and gain to the analog mixer section. The volume register contains five bits, generating 32 volume steps of 1.5 dB each for a range of 12.0 dB to –34.5 dB. This does not control the record ADC gain (see Register 0x1C).

Reg	Name	D15	D14	D13	D12	D11	D10	D9	D8	D7	D6	D5	D4	D3	D2	D1	D0	Default
0x0C	Phone Volume	M	x	x	x	x	x	x	x	x	x	x	V4	V3	V2	V1	V0	0x8008

# AD1986A

**Table 78.**

Register	Function			
V [4:0] (Volume)	Controls the gain of this input to the analog mixer from +12.0 dB to –34.5 dB. The least significant bit represents –1.5 dB.			
	MV	[4:0]	Function	Default
	0	0 0000	12 dB gain	
	0	0 1000	0 dB	Default
	0	1 1111	–34.5 dB attenuation	
	1	x xxxx	Muted	
M (Mute)	Mutes the input to the analog mixer.			Default: muted (0x1)
x	Reserved.			Default: 0

## MICROPHONE VOLUME (REGISTER 0x0E)

This register controls the MIC\_1 (left) and MIC\_2 (right) channels' gain, boost, and mute to the analog mixer section. The volume register contains five bits, generating 32 volume steps of –1.5 dB each for a range of +12.0 dB to –34.5 dB. This does not control the record ADC gain (see Register 0x1C).

In typical stereo microphone applications, the signal paths must be identical and should be set to the same gain, boost, and mute values. With stereo controls, this input is capable of using nonmicrophone sources by disabling the microphone boost (M20 bit = 0).

Reg	Name	D15	D14	D13	D12	D11	D10	D9	D8	D7	D6	D5	D4	D3	D2	D1	D0	Default
0x0E	Microphone Volume	LM	x	x	LV4	LV3	LV2	LV1	LV0	RM	M20	x	RV4	RV3	RV2	RV1	RV0	0x8888

**Table 79.**

Register	Function			
L/RV [4:0] (Left/Right Volume)	Controls the left/right channel gains of this input to the analog mixer from +12 dB to –34.5 dB. The least significant bit represents –1.5 dB.			
	L/RM	L/RV [4:0]	Function	Default
	0	0 0000	12 dB gain	
	0	0 1000	0 dB	Default
	0	1 1111	–34.5 dB attenuation	
	1	x xxxx	Mute	
M20 (MIC_1/2 Gain Boost)	Enables additional gain to increase the microphone sensitivity. This controls the boost of both the MIC_1 and MIC_2 channels. The nominal gain boost by default is 20 dB; however, MBG0 [1:0] bits (Register 0x76), allow changing the gain boost to 10 dB or 30 dB if necessary.			
	M20	MGB0 [1:0]	Boost Gain	Default
	0	xx	0 dB gain	Default: disabled
	1	00	20 dB gain	Default
	1	01	10 dB gain	
	1	x xxxx	Mute	
L/RM (Left/Right Mute)	Mutes the left/right channels independently.			Default: muted (0x1)
x	Reserved.			Default: 0



**LINE\_IN VOLUME (REGISTER 0x10)**

This register controls the LINE\_IN gain and mute to the analog mixer section. The volume register contains five bits, generating 32 volume steps of  $-1.5$  dB each for a range of  $+12.0$  dB to  $-34.5$  dB. This does not control the record ADC gain (see Register 0x1C).

Reg	Name	D15	D14	D13	D12	D11	D10	D9	D8	D7	D6	D5	D4	D3	D2	D1	D0	Default
0x10	Line In Volume	LM	x	x	LV4	LV3	LV2	LV1	LV0	RM	x	x	RV4	RV3	RV2	RV1	RV0	0x8888

**Table 80.**

Register	Function			
L/RV [4:0] (Left/Right Volume)	Controls the left/right channel gains of this input to the analog mixer from $+12$ dB to $-34.5$ dB. The least significant bit represents $-1.5$ dB.			
	<b>L/RM</b>	<b>L/RV [4:0]</b>	<b>Function</b>	<b>Default</b>
	0	0 0000	12 dB gain	
	0	0 1000	0 dB	Default
	0	1 1111	$-34.5$ dB attenuation	
	1	x xxxx	Muted	
L/RM (Left/Right Mute)	Mutes the left/right channels independently.			Default: muted (0x1)
x	Reserved.			Default: 0

**CD VOLUME (REGISTER 0x12)**

This register controls the CD gain and mute to the analog mixer section. The volume register contains five bits, generating 32 volume steps of  $-1.5$  dB each for a range of  $+12.0$  dB to  $-34.5$  dB. This does not control the record ADC gain (see Register 0x1C).

Many operating systems will play CDs directly using the digital data from the CD tracks. This control will only affect CD audio playback if it is enabled for analog and this input is connected to the CD player analog connection.

Reg	Name	D15	D14	D13	D12	D11	D10	D9	D8	D7	D6	D5	D4	D3	D2	D1	D0	Default
0x12	CD Volume	LM	x	x	LV4	LV3	LV2	LV1	LV0	RM	x	x	RV4	RV3	RV2	RV1	RV0	0x8888

**Table 81.**

Register	Function			
L/RV [4:0] (Left/Right Volume)	Controls the left/right channel gains of this input to the analog mixer from $+12$ dB to $-34.5$ dB. The least significant bit represents $-1.5$ dB.			
	<b>L/RM</b>	<b>L/RV [4:0]</b>	<b>Function</b>	<b>Default</b>
	0	0 0000	12 dB gain	
	0	0 1000	0 dB	Default
	0	1 1111	$-34.5$ dB attenuation	
	1	x xxxx	Muted	
L/RM (Left/Right Mute)	Mutes the left/right channels independently.			Default: muted (0x1)
x	Reserved.			Default: 0

# AD1986A

## AUX VOLUME (REGISTER 0x16)

This register controls the AUX\_IN gain and mute to the analog mixer section. The volume register contains five bits, generating 32 volume steps of –1.5 dB each for a range of +12.0 dB to –34.5 dB. This does not control the record ADC gain (see Register 0x1C).

Reg	Name	D15	D14	D13	D12	D11	D10	D9	D8	D7	D6	D5	D4	D3	D2	D1	D0	Default
0x16	AUX Volume	LM	x	x	LV4	LV3	LV2	LV1	LV0	RM	x	x	RV4	RV3	RV2	RV1	RV0	0x8888

Table 82.

Register	Function	Default																				
L/RV [4:0] (Left/Right Volume)	Controls the left/right channel gains of this input to the analog mixer from +12 dB to –34.5 dB. The least significant bit represents –1.5 dB.																					
	<table border="1"> <thead> <tr> <th>L/RM</th> <th>L/RV [4:0]</th> <th>Function</th> <th>Default</th> </tr> </thead> <tbody> <tr> <td>0</td> <td>0 0000</td> <td>+12 dB gain</td> <td></td> </tr> <tr> <td>0</td> <td>0 1000</td> <td>0 dB</td> <td>Default</td> </tr> <tr> <td>0</td> <td>1 1111</td> <td>–34.5 dB attenuation</td> <td></td> </tr> <tr> <td>1</td> <td>x xxxx</td> <td>Mute</td> <td></td> </tr> </tbody> </table>	L/RM	L/RV [4:0]	Function	Default	0	0 0000	+12 dB gain		0	0 1000	0 dB	Default	0	1 1111	–34.5 dB attenuation		1	x xxxx	Mute		
L/RM	L/RV [4:0]	Function	Default																			
0	0 0000	+12 dB gain																				
0	0 1000	0 dB	Default																			
0	1 1111	–34.5 dB attenuation																				
1	x xxxx	Mute																				
L/RM (Left/Right Mute)	Mutes the left/right channels independently.	Default: muted (0x1)																				
x	Reserved.	Default: 0																				

## FRONT DAC VOLUME (REGISTER 0x18)

This register controls the front DAC gain and mute to the analog mixer section. The volume register contains five bits, generating 32 volume steps of –1.5 dB each for a range of +12.0 dB to –34.5 dB.

Reg	Name	D15	D14	D13	D12	D11	D10	D9	D8	D7	D6	D5	D4	D3	D2	D1	D0	Default
0x18	Front DAC Volume	LM	x	x	LV4	LV3	LV2	LV1	LV0	RM	x	x	RV4	RV3	RV2	RV1	RV0	0x8888

Table 83.

Register	Function	Default																				
L/RV [4:0] (Left/Right Volume)	Controls the left/right channel gains of this input to the analog mixer from +12 dB to –34.5 dB. The least significant bit represents –1.5 dB.																					
	<table border="1"> <thead> <tr> <th>L/RM</th> <th>L/RV [4:0]</th> <th>Function</th> <th>Default</th> </tr> </thead> <tbody> <tr> <td>0</td> <td>0 0000</td> <td>+12 dB gain</td> <td></td> </tr> <tr> <td>0</td> <td>0 1000</td> <td>0 dB</td> <td>Default</td> </tr> <tr> <td>0</td> <td>1 1111</td> <td>–34.5 dB attenuation</td> <td></td> </tr> <tr> <td>1</td> <td>x xxxx</td> <td>Mute</td> <td></td> </tr> </tbody> </table>	L/RM	L/RV [4:0]	Function	Default	0	0 0000	+12 dB gain		0	0 1000	0 dB	Default	0	1 1111	–34.5 dB attenuation		1	x xxxx	Mute		
L/RM	L/RV [4:0]	Function	Default																			
0	0 0000	+12 dB gain																				
0	0 1000	0 dB	Default																			
0	1 1111	–34.5 dB attenuation																				
1	x xxxx	Mute																				
L/RM (Left/Right Mute)	Mutes the left/right channels independently.	Default: muted (0x1)																				
x	Reserved.	Default: 0																				

**ADC SELECT (REGISTER 0x1A)**

This register selects the record source for the ADC, independently for the right and left channels. The default value is 0x0000, which corresponds to the MIC\_1/2 input for both channels.

Reg	Name	D15	D14	D13	D12	D11	D10	D9	D8	D7	D6	D5	D4	D3	D2	D1	D0	Default
0x1A	ADC Select	x	x	x	x	x	LS2	LS1	LS0	x	x	x	x	x	RS2	RS1	RS0	0x0000

**Table 84.**

Register	LS [2:0]	Left Record Source	Function
LS [2:0] (Left Record Select)	000	MIC_1/2 selector left channel	Default
	001	CD_IN	Left
	010	Muted	–
	011	AUX_IN	Left
	100	LINE_IN	Left
	101	Stereo output mix	Left
	110	Mono output mix	Mono
	111	PHONE_IN	Mono
RS [2:0] (Right Record Select)	<b>RS [2:0]</b>	<b>Right Record Source</b>	
	000	MIC_1/2 selector left channel	Default
	001	CD_IN	Right
	010	Muted	–
	011	AUX_IN	Right
	100	LINE_IN	Right
	101	Stereo output mix	Right
	110	Mono output mix	Mono
111	PHONE_IN	Mono	

**Table 85. Microphone Selector**

OMS [2:0] <sup>1</sup>	MMIX <sup>2</sup>	2CMIC <sup>3</sup>	MS <sup>4</sup>	Left Channel <sup>5</sup>	Right Channel
000	0	0	0		MIC_1 (default)
000	0	0	1		MIC_2
000	0	1	0	MIC_1	MIC_2
000	0	1	1	MIC_2	MIC_1
000	1	x	x		MIC_1 + MIC_2 (mixed)
001	0	0	0		LINE_IN left
001	0	0	1		LINE_IN right
001	0	1	0	LINE_IN left	LINE_IN right
001	0	1	1	LINE_IN right	LINE_IN left
001	1	x	x		Line in—left + right (mixed)
01x	0	0	0		CENTER
01x	0	0	1		LFE
01x	0	1	0	CENTER	LFE
01x	0	1	1	LFE	CENTER
01x	1	x	x		CENTER + LFE (mixed)
100	0	0	0		MIC_1 + CENTER (mixed)
100	0	0	1		MIC_2 + LFE (mixed)
100	0	1	0	MIC_1 + CENTER (mixed)	MIC_2 + LFE (mixed)
100	0	1	1	MIC_2 + LFE (mixed)	MIC_1 + CENTER (mixed)
100	1	x	x		MIC_1 + MIC_2 + CENTER + LFE (mixed)

# AD1986A

OMS [2:0] <sup>1</sup>	MMIX <sup>2</sup>	2CMIC <sup>3</sup>	MS <sup>4</sup>	Left Channel <sup>5</sup>	Right Channel
101	0	0	0	MIC_1 + LINE_IN left (mixed)	MIC_1 + LINE_IN left (mixed)
101	0	0	1	MIC_2 + LINE_IN right (mixed)	MIC_2 + LINE_IN right (mixed)
101	0	1	0	MIC_1 + LINE_IN left (mixed)	MIC_2 + LINE_IN right (mixed)
101	0	1	1	MIC_2 + LINE_IN right (mixed)	MIC_1 + LINE_IN left (mixed)
101	1	x	x	MIC_1 + MIC_2 + LINE_IN left + LINE right (mixed)	MIC_1 + MIC_2 + LINE_IN left + LINE right (mixed)
110	0	0	0	LINE_IN left + CENTER (mixed)	LINE_IN left + CENTER (mixed)
110	0	0	1	LINE_IN right + LFE (mixed)	LINE_IN right + LFE (mixed)
110	0	1	0	LINE_IN left + CENTER (mixed)	LINE_IN right + LFE (mixed)
110	0	1	1	LINE_IN right + LFE (mixed)	LINE_IN left + CENTER (mixed)
110	1	x	x	LINE_IN left + LINE_IN right + CENTER + LFE (mixed)	LINE_IN left + LINE_IN right + CENTER + LFE (mixed)
111	0	0	0	MIC_1 + LINE_IN left + CENTER (mixed)	MIC_1 + LINE_IN left + CENTER (mixed)
111	0	0	1	MIC_2 + LINE_IN right + LFE (mixed)	MIC_2 + LINE_IN right + LFE (mixed)
111	0	1	0	MIC_1 + LINE_IN left + CENTER (mixed)	MIC_2 + LINE_IN right + LFE (mixed)
111	0	1	1	MIC_2 + LINE_IN right + LFE (mixed)	MIC_1 + LINE_IN left + CENTER (mixed)
111	1	x	x	MIC_1 + MIC_2 + LINE_IN left + LINE_IN right + CENTER + LFE (mixed)	MIC_1 + MIC_2 + LINE_IN left + LINE_IN right + CENTER + LFE (mixed)

<sup>1</sup> To select the alternate pins as a microphone source, see the OMS [2:0] bit (Register 0x74).

<sup>2</sup> To mix the left/right MIC channels, see MMIX bit (Register 0x7A).

<sup>3</sup> For dual MIC recording, see 2CMIC bit (Register 0x76) to enable simultaneous recording into L/R channels.

<sup>4</sup> To swap left/right MIC channels, see the MS bit (Register 0x20) for MIC\_1/2 selection.

<sup>5</sup> The MONO\_OUT pin can be connected to the left channel of the microphone selector and is affected by these bits.

## ADC VOLUME (REGISTER 0x1C)

This register controls the mute and gain of the ADC record path. The volume register contains four bits, generating 16 volume steps of 1.5 dB each for a range of 0 dB to 22.5 dB.

Reg	Name	D15	D14	D13	D12	D11	D10	D9	D8	D7	D6	D5	D4	D3	D2	D1	D0	Default
0x1C	ADC Volume	LM	x	x	x	LV3	LV2	LV1	LV0	RM	x	x	x	RV3	RV2	RV1	RV0	0x8080

Table 86.

Register	Function																	
L/RV [4:0] (Left/Right Volume)	Controls the left/right channel gains of this input to the analog mixer from 0 dB to 22.5 dB. The least significant bit represents 1.5 dB.																	
	<table border="1"> <thead> <tr> <th>L/RM</th> <th>L/RV [3:0]</th> <th>Function</th> <th>Default</th> </tr> </thead> <tbody> <tr> <td>0</td> <td>0000</td> <td>0 dB</td> <td rowspan="4">Default</td> </tr> <tr> <td>0</td> <td>1000</td> <td>12.0 dB gain</td> </tr> <tr> <td>0</td> <td>1111</td> <td>22.5 dB gain</td> </tr> <tr> <td>1</td> <td>xxxx</td> <td>Muted</td> </tr> </tbody> </table>	L/RM	L/RV [3:0]	Function	Default	0	0000	0 dB	Default	0	1000	12.0 dB gain	0	1111	22.5 dB gain	1	xxxx	Muted
	L/RM	L/RV [3:0]	Function	Default														
	0	0000	0 dB	Default														
	0	1000	12.0 dB gain															
0	1111	22.5 dB gain																
1	xxxx	Muted																
L/RM (Left/Right Mute)	Mutes the left/right channels independently.																	
x	Reserved.																	

**GENERAL-PURPOSE (REGISTER 0x20)**

This register should be read before writing to generate a mask for only the bit(s) that need to be changed.

Reg	Name	D15	D14	D13	D12	D11	D10	D9	D8	D7	D6	D5	D4	D3	D2	D1	D0	Default
0x20	General-Purpose	x	x	x	x	DRSS1	DRSS0	MIX	MS	LPBK	x	x	x	x	x	x	x	0x0000

Table 87.

Register	Function	Default
LPBK (Loop-Back Control)	This bit enables the digital internal loop back from the ADC to the front DAC. This feature is normally used for testing and troubleshooting. See LBKS bit in Register 0x74 for changing the loop back path to use the SURROUND or CENTER/LFE DACs.	Default: disabled (0x0)
MS (MIC Select)	Used in conjunction with OMS [2:0] (0x74 D10:08]), 2CMIC (0x76 D06) and MMIX (0x7A D02). Selects which MIC input goes into the ADC0 record selector's MIC channel inputs. When set, this bit swaps the left and right channels. Selects mono output audio source.	
MIX (Mono Output Select)	<b>MIX</b>	
	<b>Mono Output Connection</b>	
	0	MIX—Connected to the mono mixer output. Default
	1	MIC—Connected to the left channel of the MIC selector and swap.
DRSS [1:0] (Double Rate Slot Select)	The DRSS bits specify the slots for the n+1 sample outputs. PCM L (n+1) and PCM R (n+1) data are by default provided in output Slots 10 and 11.	
	<b>DRSS [1:0]</b>	<b>Function</b>
	00	PCM L, R (n+1) data is on Slots 10 and 11 Default
	01	PCM L, R (n+1) data is on Slots 7 and 8
1x	Reserved	
x	Reserved.	Default: 0

**AUDIO INT AND PAGING (REGISTER 0x24)**

This register controls the audio interrupt and register paging mechanisms.

Reg	Name	D15	D14	D13	D12	D11	D10	D9	D8	D7	D6	D5	D4	D3	D2	D1	D0	Default
0x24	Audio Int and Paging	I4	I3	I2	I1	I0	x	x	x	x	x	x	x	PG3	PG2	PG1	PG0	0xxx00

Table 88.

Register	Function		
PG [3:0] (Page Selector (Read/Write))	This register is used to select a descriptor of 16 word pages between Registers 0x60 to 0x6F. A value of 0x0 is used to select vendor-specific space to maintain compatibility with AC '97 Revision 2.2 vendor specific registers. System software can determine implemented pages by writing the page number and reading the value back. If the value read back does not match the value written, the page is not implemented. All implemented pages must be in consecutive order (that is, Page 0x2 cannot be implemented without Page 0x1).		
	<b>PG [3:0]</b>	<b>Addressing Page Selection</b>	<b>Default</b>
	000 (Page 0)	Page 0 (vendor) registers	Default
	001 (Page 1)	Page ID 01, registers defined in AC '97, Revision 2.3	
	Page 0x-0xF	Reserved	
I0 (Interrupt Enable (Read/Write))	Software should not unmask the interrupt unless the AC '97 controller ensures that no conflict is possible with modem Slot 12—GPI functionality. AC '97 Revision 2.2-compliant controllers will not likely support audio codec interrupt infrastructure. In that case, software can poll the interrupt status after initiating a sense cycle and waiting for sense cycle max delay (defined by software) to determine if an interrupting event has occurred.		
	<b>I0</b>	<b>Interrupt Mask Status</b>	
	0	Interrupt generation is masked Default	
	1	Interrupt generation is unmasked	

# AD1986A

Register	Function		
I1 (Sense Cycle (Read/Write))	Writing a 1 to this bit causes a sense cycle start if supported. If a sense cycle is in progress, writing a 0 to this bit will abort the sense cycle. The data in the sense result register (0x6A, Page 01) can or can not be valid, as determined by the IV bit.		
	<b>I1</b>	<b>Read</b>	<b>Write</b>
	0	Sense cycle completed (or not initiated) Default	Aborts sense cycle (if in process)
	1	Sense cycle still in process	Initiate sense cycle
These bits will indicate the cause(s) of an interrupt. This information should be used to service the correct interrupting event(s). If the Interrupt Status (Bit I4) is set, one or both of these bits must be set to indicate the interrupt cause. Hardware will reset these bits back to zero when the interrupt status bit is cleared.			
I [3:2] (Interrupt Cause (RO))	<b>I2</b>	<b>Interrupt Status</b>	
	0	Sense status has not changed (did not cause interrupt). Default	
	1	Sense cycle completed or new sense information is available	
	<b>I3</b>		
0	GPIO status change did not cause interrupt		
1	GPIO status change caused interrupt		
I4 (Interrupt Status (Read/Write))	Interrupt event is cleared by writing a 1 to this bit. The interrupt bit will change regardless of condition of interrupt enable (I0) status. An interrupt in the GPI in Slot 12 in the AC link will follow this bit change when interrupt enable (I0) is unmasked. If this bit is set, one or both of I3 or I2 must be set to indicate the interrupt cause.		
	<b>I4</b>	<b>Read</b>	<b>Write</b>
	0	Interrupt clear Default	No operation
	1	Interrupt generated	Clears interrupt
x	Reserved.		Default: 0

## POWER-DOWN CTRL/STAT (REGISTER 0x26)

The ready bits are read only; writing to REF, ANL, DAC, and ADC has no effect. These bits indicate the status for the AD1986A subsections. If the bit is 1 then that subsection is ready. 'Ready' is defined as the subsection able to perform in its nominal state.

Reg	Name	D15	D14	D13	D12	D11	D10	D9	D8	D7	D6	D5	D4	D3	D2	D1	D0	Default
0x26	Power-Down Ctrl/Stat	EAPD	PR6	PR5	PR4	PR3	PR2	PR1	PR0	x	x	x	x	REF	ANL	DAC	ADC	0x000x

Table 89.

Register	ADC	ADC Status
ADC (RO) (ADC Section Status (RO))	0	ADC not ready
	1	ADC sections ready to transmit data
ADC (RO) (Front DAC Status (RO))	<b>DAC</b>	<b>Front DAC Status</b>
	0	ADC not ready
	1	ADC sections ready to transmit data
ANL (RO) (Analog Amplifiers, Attenuators and Mixers Status (RO))	<b>ANL</b>	<b>Analog Status</b>
	0	Analog amplifiers, attenuators, and mixers not ready
	1	Analog amplifiers, attenuators, and mixers ready

Register	ADC	ADC Status
REF (RO) (Voltage References, V <sub>REF</sub> and VREF_OUT status (read only))	VREF_OUT pin output states controlled by the CVREF, MVREF, and LVREF controls in Register 0x70.	
	REF	VREF Status
	0	Voltage References, VREF and VREF_OUT not ready.
	1	Voltage References, VREF, and VREF_OUT up to nominal level.
PR0	All ADCs and input selectors' power down: clearing this bit enables VREF regardless of the state of PR3. Default: all ADCs and input muxes powered on (0x0).	
PR1	Front DACs power-down. Also powers down the EQ circuitry. Clearing this bit enables VREF regardless of the state of PR3. Default: all DACs and EQ powered on (0x0).	
PR2	Analog mixer power-down. (valid if PR7 = 0). Default: analog mixer powered on (0x0).	
PR3	All VREF and VREF_OUT pins power-down. May be used in combination with PR2 or by itself. If all the ADCs and DACs are not powered down, setting this bit will have no effect on the VREF and will only power down VREF_OUT. Default: All VREF and VREF_OUT pins powered on (0x0).	
PR4	AC-Link Interface power-down. The reference and the mixer can be either up or down, but all power-up sequences must be allowed to run to completion before PR5 and PR4 are both set. In multiple-codec systems, the master codec's PR4 bit controls the slave codec. In the slave codec the PR4 bit has no effect except to enable or disable PR5. Default: AC-link Interface powered on (0x0).	
PR5	Internal Clocks disabled. PR5 has no effect unless all ADCs, DACs, and the AC-Link are powered down (for example, PR0, PR1, PR4). The reference and the mixer can be either up or down, but all power-up sequences must be allowed to run to completion before PR5 and PR4 are both set. In multiple codec systems, the master codec's PR5 controls the slave codec. PR5 is effective in the slave codec if the master's PR5 bit is clear. Default: internal clocks enabled (0x0).	
PR6	Powers down the headphone amplifiers. Default: HP amp powered on (0x0).	
EAPD	EAPD	EAPD Pin Status
	0	Sets the EAPD pin low, enabling an external power amplifier. Default
	1	Sets the EAPD pin high, shutting the external power amplifier off.
x	Reserved. Default: 0	

### EXTENDED AUDIO ID (REGISTER 0x28)

The extended audio ID register identifies which extended audio features are supported. A nonzero extended audio ID value indicates one or more of the extended audio features are supported.

Reg	Name	D15	D14	D13	D12	D11	D10	D9	D8	D7	D6	D5	D4	D3	D2	D1	D0	Default
0x28	Ext'd Audio ID	ID1	ID0	x	X	REV1	REV0	AMAP	LDAC	SDAC	CDAC	DSA1	DSA0	x	SPDF	DRA	VRA	0x0BC7

Table 90.

Register	Description	Setting	Function					
VRA (RO)	Variable rate PCM audio: read only	= 1	Variable rate PCM audio supported					
SPDIF (RO)	SPDIF support: read only	= 1	SPDIF transmitter supported (IEC958)					
DRA (RO)	Double rate audio: read only	= 1	Double rate audio supported for DAC0 L/R					
DSA [1:0]	DAC slot assignment (read/write)							
	DSA [1:0]	Front DAC		Surround DAC		C/LFE DAC		Default
		Left	Right	Left	Right	Left	Right	
	00	3	4	7	8	6	9	Default
	01	7	8	6	9	10	11	
10	6	9	10	11	3	4		
11	10	11	3	4	7	8		

# AD1986A

Register	Description	Setting	Function
CDAC (RO)	PCM CENTER DAC: read only	= 1	PCM center DAC supported
SDAC (RO)	PCM Surround DAC: read only	= 1	CM Surround DACs supported
LDAC (RO)	PCM LFE DAC: read only	= 1	PCM LFE DAC supported
AMAP (RO)	Slot DAC mappings: read only	= 1	Codec ID based slot/DAC mappings
REV [1:0] (RO)	AC97 version: read only	= 10	Codec is AC '97, Revision 2.3-compliant
ID [1:0] (RO)	Codec configuration: read only	= 00	Primary AC '97
x	Reserved		Default: 0

## EXT'D AUDIO STAT/CTRL (REGISTER 0x2A)

The extended audio status and control register is a read/write register that provides status and control of the extended audio features.

Reg	Name	D15	D14	D13	D12	D11	D10	D9	D8	D7	D6	D5	D4	D3	D2	D1	D0	Default
0x2A	Ext'd Audio Stat/Ctrl	x	x	PRK	PRJ	PRI	SPCV	x	LDAC	SDAC	CDAC	SPSA1	SPSA0	x	SPDIF	DRA	VRA	0x0xx0

Table 91.

Register	Function	
VRA (Variable Rate Audio)	Enables variable rate audio mode. Enables sample rate registers and SLOTREQ signaling.	
	<b>VRA</b>	<b>VRA State</b> <span style="float: right;"><b>Default</b></span>
	0	Disabled, sample rate 48 kHz for all ADCs and DACs <span style="float: right;">Default</span>
1	Enabled, ADCs and DACs can be set to variable sample rates	
DRA (Double Rate Audio)	DRA = 1. Enables double-rate audio mode in which data from PCM L and PCM R in Output Slots 3 and 4 is used in conjunction with PCM L (n + 1) and PCM R (n + 1) data to provide DAC streams at twice the sample rate designated by the PCM front sample rate control register. When using the double rate audio, only the front DACs are supported and all other DACs (surround, center, and LFE) are automatically powered down. The slot that contains the additional data is determined by the DRSS [1:0] bits (0x20 D [11:10]). Note that DRA can be used without VRA, in which case the converter rates are forced to 96 kHz if DRA = 1.	
	<b>DRA</b>	<b>DRA State</b> <span style="float: right;"><b>Default</b></span>
	0	Disabled, DACs sample at the programmed rate <span style="float: right;">Default</span>
1	Enabled, DACs sample at twice (2x) the programmed rate	
SPDIF	SPDIF transmitter subsystem enable/disable bit (read/write).	
	This bit is also used to validate that the SPDIF transmitter output is actually enabled. The SPDIF bit is only allowed to be set high, if the SPDIF pin (48) is pulled down at power-up enabling the codec transmitter logic. If the SPDIF pin is floating or pulled high at power-up, the transmitter logic is disabled and therefore this bit returns a low, indicating that the SPDIF transmitter is not available. This bit must always be read back, to verify that the SPDIF transmitter is actually enabled.	
	<b>SPDIF</b>	<b>Function</b> <span style="float: right;"><b>Default</b></span>
0	Disables the S/PDIF transmitter <span style="float: right;">Default</span>	
1	Enables the S/PDIF transmitter	
AC '97 Revision 2.2 AMAP-compliant default SPDIF slot assignments.		
SPSA [1:0] (SPDIF Slot Assignment Bits: (Read/Write))	<b>SPSA [1:0]</b>	<b>S/PDIF Slot Assignment</b> <span style="float: right;"><b>Default</b></span>
	00	3 and 4 <span style="float: right;">Default</span>
	01	7 and 8
	10	6 and 9
11	10 and 11	
CDAC (RO) (Center DAC Status)	<b>CDAC</b>	<b>Center DAC Status</b>
	0	Center DAC not ready
	1	Center DAC section ready to receive data
	0	Surround DAC not ready
1	Surround DAC section ready to receive data	
LDAC (RO) (LFE DAC Status)	<b>LDAC</b>	<b>LFE DAC Status</b>
	0	LFE DAC not ready
1	LFE DAC section ready to receive data	
SPCV (RO)	Indicates the status of the SPDIF transmitter subsystem, enabling the driver to determine if the currently programmed	



Register	Function	
(SPDIF Configuration Valid)	SPDIF configuration is supported. SPCV is always valid, independent of the SPDIF enable bit status.	
	<b>SPCV</b>	<b>S/SPDIF Configuration Status</b>
	0	Invalid SPDIF configuration (SPSA, SPSR, DAC slot rate, DRS)
	1	Valid SPDIF configuration
PRI (Center DAC Power-Down)	Actual status reflected in the CDAC (0x3A D06) bit.	
	<b>PRI</b>	<b>CENTER DAC Power Status</b>
	0	Power on center DAC <span style="float:right">Default</span>
	1	Power down center DAC
PRJ (Surround DACs Power-Down)	Actual status reflected in the SDAC bit.	
	<b>PRJ</b>	<b>Surround DACs Power Control</b>
	0	Power on surround DACs <span style="float:right">Default</span>
	1	Power down surround DACs
PRK (LFE DAC Power-Down)	Actual status reflected in the LDAC bit.	
	<b>PRK</b>	<b>LFE DACs Power Control</b>
	0	Power on LFE DAC <span style="float:right">Default</span>
	1	Power down LFE DAC
x	Reserved. <span style="float:right">Default: 0</span>	

### FRONT DAC PCM RATE (REGISTER 0x2C)

This read/write sample rate control register contains 16-bit unsigned value, representing the rate of operation in Hz. If the VRA bit (0x2A D00) is 0 this register is forced to 48 kHz (0xBB80). If VRA is 1, this register can be programmed with the actual sample rate.

To use 96 kHz in AC '97 mode set the double rate audio (DRA) bit (0x2A D01). When using DRA in AC '97, only the front DACs are supported and all other DACs (surround, center, and LFE) are automatically powered down.

Reg	Name	D15	D14	D13	D12	D11	D10	D9	D8	D7	D6	D5	D4	D3	D2	D1	D0	Default
0x2C	Front DAC PCM Rate	R15	R14	R13	R12	R11	R10	R9	R8	R7	R6	R5	R4	R3	R2	R1	R0	0xBB80

Table 92.

Register	Function
R [15:0] (Sample Rate)	The sampling frequency range is from 7 kHz (0x01B58) to 48 kHz (0xBB80) in 1 Hz increments. If 0 is written to VRA, then the sample rates are reset to 48 kHz.

# AD1986A

## SURROUND DAC PCM RATE (REGISTER 0x2E)

This read/write sample rate control register contains a 16-bit unsigned value, representing the rate of operation in Hz. If the VRA bit (0x2A D00) is 0, this register is forced to 48 kHz (0xBB80). If VRA is 1, this register can be programmed with the actual sample rate.

If the DRA bit (0x2A D01) is set, the surround DAC is inoperative and automatically powered down.

Reg	Name	D15	D14	D13	D12	D11	D10	D9	D8	D7	D6	D5	D4	D3	D2	D1	D0	Default
0x2E	SURR_1 DAC PCM Rate	R15	R14	R13	R12	R11	R10	R9	R8	R7	R6	R5	R4	R3	R2	R1	R0	0xBB80

Table 93.

Register	Function
R [15:0] (Sample Rate)	The sampling frequency range is from 7 kHz (0x01B58) to 48 kHz (0xBB80) in 1 Hz increments. If zero is written to VRA then the sample rates are reset to 48 kHz.

## C/LFE DAC PCM RATE (REGISTER 0x30)

This read/write sample rate control register contains a 16-bit unsigned value, representing the rate of operation in Hz. If the VRA bit (0x2A D00) is 0 this register is forced to 48 kHz (0xBB80). If VRA is 1, this register can be programmed with the actual sample rate.

If the DRA bit (0x2A D01) is set, the C/LFE DAC is inoperative and automatically powered down.

Reg	Name	D15	D14	D13	D12	D11	D10	D9	D8	D7	D6	D5	D4	D3	D2	D1	D0	Default
0x30	C/LFE DAC PCM Rate	R15	R14	R13	R12	R11	R10	R9	R8	R7	R6	R5	R4	R3	R2	R1	R0	0xBB80

Table 94.

Register	Function
R [15:0] (Sample Rate)	The sampling frequency range is from 7 kHz (0x01B58) to 48 kHz (0xBB80) in 1 Hz increments. If 0 is written to VRA then the sample rates are reset to 48 kHz.

## ADC PCM RATE (REGISTER 0x32)

This read/write sample rate control register contains 16-bit unsigned value, representing the rate of operation in Hz. If the VRA bit (0x2A D00) is 0 (zero) this register is forced to 48 kHz (0xBB80). If VRA is 1, this register can be programmed with the actual sample rate.

Reg	Name	D15	D14	D13	D12	D11	D10	D9	D8	D7	D6	D5	D4	D3	D2	D1	D0	Default
0x32	ADC 0 PCM Rate	R15	R14	R13	R12	R11	R10	R9	R8	R7	R6	R5	R4	R3	R2	R1	R0	0xBB80

Table 95.

Register	Function
R [15:0] (Sample Rate)	The sampling frequency range is from 7 kHz (0x01B58) to 48 kHz (0xBB80) in 1 Hz increments. If 0 is written to VRA then the sample rates are reset to 48 kHz.

**C/LFE DAC VOLUME (REGISTER 0x36)**

This register controls the CENTER/LFE DAC gain and mute to the output selector section. The volume register contains five bits, generating 32 volume steps of  $-1.5$  dB each for a range of  $+12.0$  dB to  $-34.5$  dB.

Note that the left/right association of the center and LFE channels can be swapped at the codec outputs by setting the CSWP bit in Register 0x74. These controls remain unchanged regardless of the state of CSWP.

Reg	Name	D15	D14	D13	D12	D11	D10	D9	D8	D7	D6	D5	D4	D3	D2	D1	D0	Default
0x36	C/LFE DAC Volume	LFEM	x	x	LFE4	LFE3	LFE2	LFE1	LFE0	CNTM	x	x	CNT4	CNT3	CNT2	CNT1	CNT0	0x8888

**Table 96.**

Register	Function																				
CNT [4:0] (Center Volume)	Controls the gain of the center channel to the output selector section from $+12.0$ dB to $-34.5$ dB. The least significant bit represents $-1.5$ dB.																				
	<table border="1"> <thead> <tr> <th>CNTM</th> <th>CNT [4:0]</th> <th>Function</th> <th>Default</th> </tr> </thead> <tbody> <tr> <td>0</td> <td>0 0000</td> <td><math>+12</math> dB gain</td> <td></td> </tr> <tr> <td>0</td> <td>0 1000</td> <td>0 dB attenuation</td> <td>Default</td> </tr> <tr> <td>0</td> <td>1 1111</td> <td><math>-34.5</math> dB attenuation</td> <td></td> </tr> <tr> <td>1</td> <td>x xxxx</td> <td>Muted</td> <td></td> </tr> </tbody> </table>	CNTM	CNT [4:0]	Function	Default	0	0 0000	$+12$ dB gain		0	0 1000	0 dB attenuation	Default	0	1 1111	$-34.5$ dB attenuation		1	x xxxx	Muted	
	CNTM	CNT [4:0]	Function	Default																	
	0	0 0000	$+12$ dB gain																		
	0	0 1000	0 dB attenuation	Default																	
0	1 1111	$-34.5$ dB attenuation																			
1	x xxxx	Muted																			
CNTM (Center Mute)	Mutes the center channel. Default: muted (0x1)																				
LFE [4:0] (LFE Volume)	Controls the gain of the LFE channel to the output selector section from $+12.0$ dB to $-34.5$ dB. The least significant bit represents $-1.5$ dB.																				
	<table border="1"> <thead> <tr> <th>LFEM</th> <th>LFE[4:0]</th> <th>Function</th> <th>Default</th> </tr> </thead> <tbody> <tr> <td>0</td> <td>0 0000</td> <td><math>+12</math> dB gain</td> <td></td> </tr> <tr> <td>0</td> <td>0 1000</td> <td>0 dB attenuation</td> <td>Default</td> </tr> <tr> <td>0</td> <td>1 1111</td> <td><math>-34.5</math> dB attenuation</td> <td></td> </tr> <tr> <td>1</td> <td>x xxxx</td> <td>Muted</td> <td></td> </tr> </tbody> </table>	LFEM	LFE[4:0]	Function	Default	0	0 0000	$+12$ dB gain		0	0 1000	0 dB attenuation	Default	0	1 1111	$-34.5$ dB attenuation		1	x xxxx	Muted	
	LFEM	LFE[4:0]	Function	Default																	
	0	0 0000	$+12$ dB gain																		
	0	0 1000	0 dB attenuation	Default																	
0	1 1111	$-34.5$ dB attenuation																			
1	x xxxx	Muted																			
LFEM (LFE Mute)	Mutes the LFE channel. Default: muted (0x1)																				
x	Reserved. Default: 0																				

**SURROUND DAC VOLUME (REGISTER 0x38)**

This register controls the surround DAC gain and mute to the output selector section. The volume register contains five bits, generating 32 volume steps of  $-1.5$  dB each for a range of  $+12.0$  dB to  $-34.5$  dB.

Reg	Name	D15	D14	D13	D12	D11	D10	D9	D8	D7	D6	D5	D4	D3	D2	D1	D0	Default
0x18	Surround DAC Volume	LM	x	x	LV4	LV3	LV2	LV1	LV0	RM	x	x	RV4	RV3	RV2	RV1	RV0	0x8888

**Table 97.**

Register	Function																				
L/RV [4:0] (Left/Right Volume)	Controls the left/right channel gains of this input to the output selector section from $+12$ dB to $-34.5$ dB. The least significant bit represents $-1.5$ dB.																				
	<table border="1"> <thead> <tr> <th>L/RM</th> <th>L/RV [4:0]</th> <th>Function</th> <th>Default</th> </tr> </thead> <tbody> <tr> <td>0</td> <td>0 0000</td> <td><math>+12</math> dB gain</td> <td></td> </tr> <tr> <td>0</td> <td>0 1000</td> <td>0 dB</td> <td>Default</td> </tr> <tr> <td>0</td> <td>1 1111</td> <td><math>-34.5</math> dB attenuation</td> <td></td> </tr> <tr> <td>1</td> <td>x xxxx</td> <td>Muted</td> <td></td> </tr> </tbody> </table>	L/RM	L/RV [4:0]	Function	Default	0	0 0000	$+12$ dB gain		0	0 1000	0 dB	Default	0	1 1111	$-34.5$ dB attenuation		1	x xxxx	Muted	
	L/RM	L/RV [4:0]	Function	Default																	
	0	0 0000	$+12$ dB gain																		
	0	0 1000	0 dB	Default																	
0	1 1111	$-34.5$ dB attenuation																			
1	x xxxx	Muted																			
L/RM (Left/Right Mute)	Mutes the left/right channels independently. Default: muted (0x1)																				
x	Reserved. Default: 0																				

# AD1986A

## SPDIF CONTROL (REGISTER 0x3A)

Register 0x3A is a read/write register that controls SPDIF functionality and manages bit fields propagated as channel status (or subframe in the V-case). With the exception of V, this register should only be written to when the SPDIF transmitter is disabled (SPDIF bit in Register 0x2A is 0). This ensures that control and status information start up correctly at the beginning of SPDIF transmission.

Reg	Name	D15	D14	D13	D12	D11	D10	D9	D8	D7	D6	D5	D4	D3	D2	D1	D0	Default
0x3A	SPDIF Control	V	VCFG	SPSR	x	L	CC6	CC5	CC4	CC3	CC2	CC1	CC0	PRE	COPY	/AUDIO	PRO	20000x

Table 98.

Register	Function																				
PRO (Professional)	Indicates professional use of the audio stream.																				
	<table border="1"> <thead> <tr> <th>PRO</th> <th>State</th> <th>Default</th> </tr> </thead> <tbody> <tr> <td>0</td> <td>Consumer use of channel</td> <td>Default</td> </tr> <tr> <td>1</td> <td>Professional use of channel</td> <td></td> </tr> </tbody> </table>	PRO	State	Default	0	Consumer use of channel	Default	1	Professional use of channel												
	PRO	State	Default																		
0	Consumer use of channel	Default																			
1	Professional use of channel																				
/AUDIO (Nonaudio)	Indicates that the data is PCM or another format (such as AC3).																				
	<table border="1"> <thead> <tr> <th>/AUDIO</th> <th>State</th> <th>Default</th> </tr> </thead> <tbody> <tr> <td>0</td> <td>Data in PCM format</td> <td>Default</td> </tr> <tr> <td>1</td> <td>Data in non-PCM format</td> <td></td> </tr> </tbody> </table>	/AUDIO	State	Default	0	Data in PCM format	Default	1	Data in non-PCM format												
	/AUDIO	State	Default																		
0	Data in PCM format	Default																			
1	Data in non-PCM format																				
COPY (Copyright)	Allows receivers to make copies of the digital data.																				
	<table border="1"> <thead> <tr> <th>COPY</th> <th>State</th> <th>Default</th> </tr> </thead> <tbody> <tr> <td>0</td> <td>Copyright asserted</td> <td>Default</td> </tr> <tr> <td>1</td> <td>Copyright not asserted</td> <td></td> </tr> </tbody> </table>	COPY	State	Default	0	Copyright asserted	Default	1	Copyright not asserted												
	COPY	State	Default																		
0	Copyright asserted	Default																			
1	Copyright not asserted																				
PRE (Pre-emphasis)	Disables filter pre-emphasis.																				
	<table border="1"> <thead> <tr> <th>PRE</th> <th>State</th> <th>Default</th> </tr> </thead> <tbody> <tr> <td>0</td> <td>Filter pre-emphasis is 50/15 <math>\mu</math>sec</td> <td>Default</td> </tr> <tr> <td>1</td> <td>No pre-emphasis</td> <td></td> </tr> </tbody> </table>	PRE	State	Default	0	Filter pre-emphasis is 50/15 $\mu$ sec	Default	1	No pre-emphasis												
	PRE	State	Default																		
0	Filter pre-emphasis is 50/15 $\mu$ sec	Default																			
1	No pre-emphasis																				
CC [6:0] (Category Code)	Programmed according to IEC standards, or as appropriate.																				
L (Generation Level)	Programmed according to IEC standards, or as appropriate.																				
SPSR (SPDIF Transmit Sample Rate)	Chooses between 48.0 kHz and 44.1 kHz S/PDIF transmitter rate.																				
	<table border="1"> <thead> <tr> <th>SPSR</th> <th>Transmit Sample Rate</th> <th>Default</th> </tr> </thead> <tbody> <tr> <td>0</td> <td>44.1 kHz</td> <td></td> </tr> <tr> <td>1</td> <td>48.0 kHz</td> <td>Default</td> </tr> </tbody> </table>	SPSR	Transmit Sample Rate	Default	0	44.1 kHz		1	48.0 kHz	Default											
	SPSR	Transmit Sample Rate	Default																		
0	44.1 kHz																				
1	48.0 kHz	Default																			
VCFG (Validity Force Bit)	When asserted, this bit forces the SPDIF stream validity flag (Bit 28 within each SPDIF L/R subframe) to be controlled by the validity bit (D15) in Register 0x3A (SPDIF control register).																				
	<table border="1"> <thead> <tr> <th>VCFG</th> <th>V</th> <th>Validity Bit State</th> <th>Reset Default: 0</th> </tr> </thead> <tbody> <tr> <td>0</td> <td>0</td> <td>Managed by codec error detection logic</td> <td>Default</td> </tr> <tr> <td>0</td> <td>1</td> <td>Forced high, indicating subframe data is invalid</td> <td></td> </tr> <tr> <td>1</td> <td>0</td> <td>Forced low, indicating subframe data is valid</td> <td></td> </tr> <tr> <td>1</td> <td>1</td> <td>Forced high, indicating subframe data is invalid</td> <td></td> </tr> </tbody> </table>	VCFG	V	Validity Bit State	Reset Default: 0	0	0	Managed by codec error detection logic	Default	0	1	Forced high, indicating subframe data is invalid		1	0	Forced low, indicating subframe data is valid		1	1	Forced high, indicating subframe data is invalid	
	VCFG	V	Validity Bit State	Reset Default: 0																	
	0	0	Managed by codec error detection logic	Default																	
	0	1	Forced high, indicating subframe data is invalid																		
1	0	Forced low, indicating subframe data is valid																			
1	1	Forced high, indicating subframe data is invalid																			
V (Validity)	This bit affects the validity flag, (Bit 28 transmitted in each SPDIF L/R subframe) and enables the SPDIF transmitter to maintain connection during error or mute conditions. Note that the VCFG bit (0x3A D14) will force the validity flag high (valid) or low (invalid). See the VCFG bit description.																				
	<table border="1"> <thead> <tr> <th>V</th> <th>State</th> <th>Default</th> </tr> </thead> <tbody> <tr> <td>0</td> <td>Each SPDIF subframe (L+R) has Bit 28 set to 1 This tags both samples as invalid</td> <td>Default</td> </tr> <tr> <td>1</td> <td>Each SPDIF subframe (L+R) has Bit 28 set to 0 for valid data and 1 for invalid data (error condition)</td> <td></td> </tr> </tbody> </table>	V	State	Default	0	Each SPDIF subframe (L+R) has Bit 28 set to 1 This tags both samples as invalid	Default	1	Each SPDIF subframe (L+R) has Bit 28 set to 0 for valid data and 1 for invalid data (error condition)												
	V	State	Default																		
0	Each SPDIF subframe (L+R) has Bit 28 set to 1 This tags both samples as invalid	Default																			
1	Each SPDIF subframe (L+R) has Bit 28 set to 0 for valid data and 1 for invalid data (error condition)																				
x	Reserved. Default: 0																				

## EQ CONTROL REGISTER (REGISTER 0x60)

Register 0x60 is a read/write register that controls equalizer function and data setup. The register also contains the biquad and coefficient address pointer, which is used in conjunction with the EQ data register (0x78) to set up the equalizer coefficients. The reset default disables the equalizer function until the coefficients can be properly set up by the software and sets the symmetry bit to allow equal coefficients for left and right channels.

Reg	Name	D15	D14	D13	D12	D11	D10	D9	D8	D7	D6	D5	D4	D3	D2	D1	D0	Default
0x60	EQ Control	EQM	x	x	x	x	x	x	x	SYM	CHS	BCA5	BCA4	BCA3	BCA2	BCA1	BCA0	0x8080

**Table 99. Biquad and Coefficient Address Pointer**

BCA [5,0]	Biquad 0	Coef a0	BCA [5,0] = 011011	Biquad 3	Coef b1	BCA [5,0] = 101100
	Biquad 0	Coef a1	BCA [5,0] = 011010	Biquad 3	Coef b2	BCA [5,0] = 101011
	Biquad 0	Coef a2	BCA [5,0] = 011001			
	Biquad 0	Coef b1	BCA [5,0] = 011101	Biquad 4	Coef a0	BCA [5,0] = 101111
	Biquad 0	Coef b2	BCA [5,0] = 011100	Biquad 4	Coef a1	BCA [5,0] = 101110
				Biquad 4	Coef a2	BCA [5,0] = 101101
	Biquad 1	Coef a0	BCA [5,0] = 100000	Biquad 4	Coef b1	BCA [5,0] = 110001
	Biquad 1	Coef a1	BCA [5,0] = 011111	Biquad 4	Coef b2	BCA [5,0] = 110000
	Biquad 1	Coef a2	BCA [5,0] = 011110			
	Biquad 1	Coef b1	BCA [5,0] = 100010	Biquad 5	Coef a0	BCA [5,0] = 110100
	Biquad 1	Coef b2	BCA [5,0] = 100001	Biquad 5	Coef a1	BCA [5,0] = 110011
				Biquad 5	Coef a2	BCA [5,0] = 110010
	Biquad 2	Coef a0	BCA [5,0] = 100101	Biquad 5	Coef b1	BCA [5,0] = 110110
	Biquad 2	Coef a1	BCA [5,0] = 100100	Biquad 5	Coef b2	BCA [5,0] = 110101
	Biquad 2	Coef a2	BCA [5,0] = 100011			
	Biquad 2	Coef b1	BCA [5,0] = 100111	Biquad 6	Coef a0	BCA [5,0] = 111001
	Biquad 2	Coef b2	BCA [5,0] = 100110	Biquad 6	Coef a1	BCA [5,0] = 111000
				Biquad 6	Coef a2	BCA [5,0] = 110111
	Biquad 3	Coef a0	BCA [5,0] = 101010	Biquad 6	Coef b1	BCA [5,0] = 111011
	Biquad 3	Coef a1	BCA [5,0] = 101001	Biquad 6	Coef b2	BCA [5,0] = 111010
	Biquad 3	Coef a2	BCA [5,0] = 101000			

**Table 100.**

Register	Function		
CHS (Channel Select)	Swaps the blocks that are used for symmetry coefficients. Only valid when the SYM bit is set.		
	CHS	Function	Default
	0	Selects left channel coefficients' data block	Default
	1	Selects right channel coefficients' data block	
SYM (Symmetry)	When set to 1 this bit indicates that the left and right channel coefficients are equal.		
	This shortens the coefficients setup sequence since only the left channel coefficients need to be addressed and set up. The right channel coefficients are simultaneously copied into memory.		
	SYM	Function	Default
	0	Left and right channels can use different coefficients	
	1	Indicates that the left and right channel coefficients are equal	Default
EQM (Equalizer Mute)	When set to 1, this bit disables the equalizer function (allows all data to pass through). The reset default sets this bit to 1, disabling the equalizer function until the biquad coefficients can be properly set.		
	EQM	Function	Default
	0	EQ is enabled.	
	1	EQ is disabled. Data will pass-through without change.	Default
x	Reserved.		Default: 0

# AD1986A

## EQ DATA REGISTER (REGISTER 0x62)

This read/write register is used to transfer EQ biquad coefficients into memory. The register data is transferred to, or retrieved from, the address pointed by the BCA bits in the EQ CNTRL register (0x60). Data will only be written to memory, if the EQM bit (Register 0x60 Bit 15) is asserted.

Reg	Name	D15	D14	D13	D12	D11	D10	D9	D8	D7	D6	D5	D4	D3	D2	D1	D0	Default
0x62	EQ Data	CFD15	CFD14	CFD13	CFD12	CFD11	CFD10	CFD9	CFD8	CFD7	CFD6	CFD5	CFD4	CFD3	CFD2	CFD1	CFD0	0xxxxx

Table 101.

Register	Function
CFD [15:0] (Coefficient Data)	The biquad coefficients are fixed point format values with 16 bits of resolution. The CFD15 bit is the MSB and the CFD0 bit is the LSB.

## MISC CONTROL BITS 2 (REGISTER 0x70)

Reg	Name	D15	D14	D13	D12	D11	D10	D9	D8	D7	D6	D5	D4	D3	D2	D1	D0	Default
0x70	Misc Control Bits 2	x	x	x	MVREF 2	MVREF 1	MVREF 0	x	x	MMDIS	x	JSMAP	CVREF 2	CVREF 1	CVREF 0	x	x	0x0000

Table 102.

Register	Function																		
CVREF [2:0] (C/LFE VREF_OUT Control)	<p>Sets the voltage/state of the C/LFE VREF_OUT signal. VREF_OUT is used to power microphone style devices plugged into the connected jack circuitry. The VREF_OUT pin must be connected to both the left and right channels through external resistors to function properly. Selections other than those defined are invalid and should not be programmed.</p> <table border="1"> <thead> <tr> <th colspan="3">C/LFE VREF_OUT Setting</th> </tr> <tr> <th>CVREF [2:0]</th> <th>5.0 AV<sub>DD</sub></th> <th>Default</th> </tr> </thead> <tbody> <tr> <td>000</td> <td>Hi-Z</td> <td>Default</td> </tr> <tr> <td>001</td> <td>2.25 V</td> <td></td> </tr> <tr> <td>010</td> <td>0 V</td> <td></td> </tr> <tr> <td>100</td> <td>3.70 V</td> <td></td> </tr> </tbody> </table>	C/LFE VREF_OUT Setting			CVREF [2:0]	5.0 AV <sub>DD</sub>	Default	000	Hi-Z	Default	001	2.25 V		010	0 V		100	3.70 V	
C/LFE VREF_OUT Setting																			
CVREF [2:0]	5.0 AV <sub>DD</sub>	Default																	
000	Hi-Z	Default																	
001	2.25 V																		
010	0 V																		
100	3.70 V																		
JSMAP (Jack Sense Mapping)	<p>The AD1986A supports two different methods of mapping the JACK_SENSE_A/B resistor tree to bits JS [7:0]. Use these bits to change from the default mapping to the alternate method.</p> <table border="1"> <thead> <tr> <th>JSMAP</th> <th>Function</th> <th>Default</th> </tr> </thead> <tbody> <tr> <td>0</td> <td>Default jack sense mapping</td> <td>Default</td> </tr> <tr> <td>1</td> <td>Alternate jack sense mapping</td> <td></td> </tr> </tbody> </table>	JSMAP	Function	Default	0	Default jack sense mapping	Default	1	Alternate jack sense mapping										
JSMAP	Function	Default																	
0	Default jack sense mapping	Default																	
1	Alternate jack sense mapping																		
MMDIS (Mono Mute Disable)	<p>Disables the automatic muting of the MONO_OUT pin by jack sense events (see advanced jack sense bits JS [3:0] (0x76 D [05:04], 0x72 D [05:04])).</p> <table border="1"> <thead> <tr> <th>MMDIS</th> <th>Function</th> <th>Default</th> </tr> </thead> <tbody> <tr> <td>0</td> <td>Automute can occur</td> <td>Default</td> </tr> <tr> <td>1</td> <td>Automute disabled</td> <td></td> </tr> </tbody> </table>	MMDIS	Function	Default	0	Automute can occur	Default	1	Automute disabled										
MMDIS	Function	Default																	
0	Automute can occur	Default																	
1	Automute disabled																		
MVREF [2:0] (MIC VREF_OUT)	<p>Sets the voltage/state of the microphone VREF_OUT signal. VREF_OUT is used to power microphone-style devices plugged into the connected jack circuitry. The VREF_OUT pin must be connected to both the left and right channels through external resistors to function properly. Selections other than those defined are invalid and should not be programmed.</p> <table border="1"> <thead> <tr> <th colspan="3">MIC_1/2 VREF_OUT Setting</th> </tr> <tr> <th>MVREF [2:0]</th> <th>5.0 AV<sub>DD</sub></th> <th>Default</th> </tr> </thead> <tbody> <tr> <td>000</td> <td>Hi-Z</td> <td>Default</td> </tr> <tr> <td>001</td> <td>2.25 V</td> <td></td> </tr> <tr> <td>010</td> <td>0 V</td> <td></td> </tr> <tr> <td>100</td> <td>3.70 V</td> <td></td> </tr> </tbody> </table>	MIC_1/2 VREF_OUT Setting			MVREF [2:0]	5.0 AV <sub>DD</sub>	Default	000	Hi-Z	Default	001	2.25 V		010	0 V		100	3.70 V	
MIC_1/2 VREF_OUT Setting																			
MVREF [2:0]	5.0 AV <sub>DD</sub>	Default																	
000	Hi-Z	Default																	
001	2.25 V																		
010	0 V																		
100	3.70 V																		
x	Reserved. <span style="float: right;">Default: 0</span>																		

**JACK SENSE (REGISTER 0x72)**

All register bits are read/write except for JS0ST and JS1ST, which are read only. Important: Refer to Table 103 to understand how JACK\_SENSE\_A and JACK\_SENSE\_B codec pins translate to JS1 and JS0.

Reg	Name	D15	D14	D13	D12	D11	D10	D9	D8	D7	D6	D5	D4	D3	D2	D1	D0	Default
0x72	Jack Sense	JS1 SPRD	JS1 DMX	JS0 DMX	JSMT 2	JSMT 1	JSMT 0	JS1 EQB	JS0 EQB	x	x	JS1 MD	JS0 MD	JS1 ST	JS0 ST	JS1 INT	JS0 INT	0x0000

**Table 103.**

Register	Function
JS0INT (JS0 Interrupt Status)	Indicates JS0 has generated an interrupt. Remains set until the software services JS0 interrupt; that is, JS0 ISR should clear this bit by writing a 0 to it. Interrupts are generated by valid state changes of JS pins. Interrupt to the system is actually an OR combination of this bit and JS3 JS0 INT. The interrupt implementation path is selected by the INTS bit (Register 0x74). It is also possible to generate a software system interrupt by writing a 1 to this bit.
	<b>JS0INT</b> <b>Read</b> <b>Write</b>
	0                                      JS0 did not generate interrupt    No operation 1                                      JS0 generated interrupt    Clears JS0INT bit
JS1INT (JS1 Interrupt Status)	Indicates JS1 has generated an interrupt. Remains set until the software services JS1 interrupt; that is, JS1 ISR should clear this bit by writing a 0 to it. See the JS0INT description above for additional details.
	<b>JS1INT</b> <b>Read</b> <b>Write</b>
	0                                      JS1 did not generate interrupt    No operation 1                                      JS1 generated interrupt    Clears JS1INT
JS0ST (RO) (JS0 State)	This bit always reports the logic state of JS0. On MIC jack sensing, depending on the applications circuit, the logic state for jack sense pins can be the opposite to that on other jacks. Software needs to be aware that this interprets the JS event as a plug in the out event.
	<b>JS0ST</b> <b>Function</b> <b>Default</b>
	0                                      JS0 is low (0) 1                                      JS0 is high (1)
JS1ST (RO) (JS1 State)	This bit always reports the logic state of JS1. MIC jack sensing, depending on the applications circuit, the logic state for JS pins can be the opposite to the other jacks.
	<b>JS1ST</b> <b>Function</b>
	0                                      JS1 is low (0) 1                                      JS is high (1)
JS0MD (JS0 Mode)	This bit selects the operation mode for JS0.
	<b>JS0MD</b> <b>Function</b>
	0                                      Jack sense mode—JS0INT must be polled by software    Default 1                                      Interrupt mode—codec will generate an interrupt on JS0 event
JS1MD (JS1 Mode)	This bit selects the operation mode for JS1.
	<b>JS1MD</b> <b>Function</b>
	0                                      Jack sense mode—JS1INT must be polled by software    Default 1                                      Interrupt mode—codec will generate an interrupt on JS1 event
JS0EQB (JS0 EQ Bypass Enable)	This bit enables JS0 to control the EQ bypass. When this bit is set to 1, JS0 = 1 will cause the EQ to be bypassed.
	<b>JS0EQB</b> <b>Function</b>
	0                                      JS0 does not affect EQ    Default 1                                      JS0 = 1 will cause the EQ to be bypassed
JS1EQB (JS1 EQ Bypass Enable)	This bit enables JS1 to control the EQ bypass. When this bit is set to 1, JS1=1 will cause the EQ to be bypassed.
	<b>JS1EQB</b> <b>Function</b>
	0                                      JS1 does not affect EQ    Default 1                                      JS1 = 1 will cause the EQ to be bypassed

# AD1986A

Register	Function	
JSMT [2,0] (JS Mute Enable selector)	These three bits select and enable the jack sense muting action. See Table 104.	
JS0DMX (JS0 Down-Mix Control Enable)	This bit enables JS0 to control the down-mix function. This function allows a digital mix of 6-channel audio into 2-channel audio. The mix can then be routed to the stereo LINE_OUT or HP_OUT jacks. When this bit is set to 1, JS0 = 1 will activate the down-mix conversion. See the DMIX description in Register 0x76. The DMIX bits select the down-mix implementation type and can also force the function to be activated.	
	<b>JS0DMX</b>	<b>Function</b>
	0	JS0 does not affect down mix <span style="float: right;">Default</span>
1	JS0 = 1 activates the 6- to 2-channel down mix	
JS1DMX (JS1 Down-Mix Control Enable)	This bit enables JS1 to control the down-mix function (see the JS0DMx description above). When this bit is set to 1, JS1 = 1 will activate the down-mix conversion.	
	<b>JS1DMX</b>	<b>Function</b>
	0	JS1 does not affect down-mix <span style="float: right;">Default</span>
1	JS1 = 1 activates the 6- to 2-channel down-mix	
JSSPRD (JS Spread control enable)	This bit enables the 2-channel to 6-channel audio spread function when JSs are active (Logic State 1). Note that the SPRD bit can also force the Spread function without being gated by the jack senses. Please see this bit's description in Register 0x76 for a better understanding of the Spread function.	
	<b>JSSPRD</b>	<b>Function</b>
	0	JS1 does not affect spread <span style="float: right;">Default</span>
1	J10 = 1 activates spread	
x	Reserved. <span style="float: right;">Default: 0</span>	

**Table 104. Jack Sense Mute Selections (JSMT)**

REF	JS1	JS0	JSMT2	JSMT1	JSMT0	HP OUT	LINE OUT	C/LFE OUT	SURR OUT	MONO OUT	NOTES
0	OUT (0)	OUT (0)	0	0	0	ACTIVE	ACTIVE	ACTIVE	ACTIVE	ACTIVE	JS0 and JS1 ignored
1	OUT (0)	IN (1)	0	0	0	ACTIVE	ACTIVE	ACTIVE	ACTIVE	ACTIVE	
2	IN (1)	OUT (0)	0	0	0	ACTIVE	ACTIVE	ACTIVE	ACTIVE	ACTIVE	
3	IN (1)	IN (1)	0	0	0	ACTIVE	ACTIVE	ACTIVE	ACTIVE	ACTIVE	
4	OUT (0)	OUT (0)	0	0	1	ACTIVE	FMUTE	FMUTE	FMUTE	ACTIVE	JS0 no mute action JS1 mutes mono and enables LINE_OUT + SURR_OUT + C/LFE
5	OUT (0)	IN (1)	0	0	1	ACTIVE	FMUTE	FMUTE	FMUTE	ACTIVE	
6	IN (1)	OUT (0)	0	0	1	ACTIVE	ACTIVE	ACTIVE	ACTIVE	FMUTE	STANDARD 6 CHAN CONFIG
7	IN (1)	IN (1)	0	0	1	ACTIVE	ACTIVE	ACTIVE	ACTIVE	FMUTE	
8	OUT (0)	OUT (0)	0	1	0	FMUTE	ACTIVE	FMUTE	FMUTE	ACTIVE	JS0 no mute action, SWAPPED HP_OUT and LINE_OUT JS1 mutes mono and enables HP_OUT + SURR_OUT + C/LFE
9	OUT (0)	IN (1)	0	1	0	FMUTE	ACTIVE	FMUTE	FMUTE	ACTIVE	
10	IN (1)	OUT (0)	0	1	0	ACTIVE	ACTIVE	ACTIVE	ACTIVE	FMUTE	Standard six Channel Configuration no swap
11	IN (1)	IN (1)	0	1	0	ACTIVE	ACTIVE	ACTIVE	ACTIVE	FMUTE	
12	OUT (0)	OUT (0)	0	1	1	**	**	**	**	**	**Reserved
13	OUT (0)	IN (1)	0	1	1	**	**	**	**	**	
14	IN (1)	OUT (0)	0	1	1	**	**	**	**	**	
15	IN (1)	IN (1)	0	1	1	**	**	**	**	**	
16	OUT (0)	OUT (0)	1	0	0	ACTIVE	FMUTE	FMUTE	FMUTE	ACTIVE	JS0 = 0 and JS1 = 0 enables MONO
17	OUT (0)	IN (1)	1	0	0	ACTIVE	ACTIVE	ACTIVE	ACTIVE	FMUTE	JS1 = 1 enabled FRONT only
18	IN (1)	OUT (0)	1	0	0	ACTIVE	FMUTE	FMUTE	FMUTE	FMUTE	JS0 = 1 and JS1 = 0 enables all rear
19	IN (1)	IN (1)	1	0	0	ACTIVE	FMUTE	FMUTE	FMUTE	FMUTE	6 CHAN CONFIG with front jack wrap back



REF	JS1	JS0	JSMT2	JSMT1	JSMT0	HP OUT	LINE OUT	C/LFE OUT	SURR OUT	MONO OUT	NOTES
20	OUT (0)	OUT (0)	1	0	1	FMUTE	FMUTE	FMUTE	FMUTE	ACTIVE	JS0 no mute action JS1 mutes mono and enables all rear.
21	OUT (0)	IN (1)	1	0	1	FMUTE	FMUTE	FMUTE	FMUTE	ACTIVE	
22	IN (1)	OUT (0)	1	0	1	ACTIVE	ACTIVE	ACTIVE	ACTIVE	FMUTE	Standard six channel configuration swapped HP_OUT and LINE_OUT
23	IN (1)	IN (1)	1	0	1	ACTIVE	ACTIVE	ACTIVE	ACTIVE	FMUTE	
24	OUT (0)	OUT (0)	1	1	0	**	**	**	**	**	**RESERVED
25	OUT (0)	IN (1)	1	1	0	**	**	**	**	**	
26	IN (1)	OUT (0)	1	1	0	**	**	**	**	**	
27	IN (1)	IN (1)	1	1	0	**	**	**	**	**	
28	OUT (0)	OUT (0)	1	1	1	**	**	**	**	**	**RESERVED
29	OUT (0)	IN (1)	1	1	1	**	**	**	**	**	
30	IN (1)	OUT (0)	1	1	1	**	**	**	**	**	
31	IN (1)	IN (1)	1	1	1	**	**	**	**	**	

FMUTE = Output is forced to mute independent of the respective volume register setting.

ACTIVE = Output is not muted and its status is dependent on the respective volume register setting.

OUT = Nothing is plugged into the jack and therefore the JS status is 0 (via the load resistor pull-down action).

IN = Jack has plug inserted and therefore the JS status is 1 (via the codec JS pin internal pull-up).

### SERIAL CONFIGURATION (REGISTER 0x74)

When Register 0x00 is written (soft reset) the SLOT 16, REGM [2:0], SPOVR, SPAL, SPDZ, and SPLNK bits do not reset. All bits are reset on a hardware reset or power-on reset.

Reg	Name	D15	D14	D13	D12	D11	D10	D9	D8	D7	D6	D5	D4	D3	D2	D1	D0	Default
0x74	Serial Configuration	SLOT 16	REGM2	REGM1	REGM0	REGM3	OMS2	OMS1	OM0	SPOVR	LBKS1	LBKS0	INTS	CSWP	SPAL	SPDZ	SP LNK	0x1001

Table 105.

Register	Function	Default
SPLNK (S/PDIF LINK)	This bit enables S/PDIF to link with the front DACs for data requesting. When linked, the S/PDIF and front DACs should be set to the same data rate because they both generate data requests at the front DACs request rate.	
	<b>SPLNK</b>	<b>Function</b>
	0	S/PDIF and front DACs are not linked
1	S/PDIF and front DACs are linked	Default
SPDZ (S/PDIF DACZ)	Sets data fill mode for S/PDIF transmitter FIFO under-runs. When this bit is set to on (1), the S/PDIF and ADC rates should be set to the same rate.	
	<b>SPDZ</b>	<b>On Under-Runs</b>
	0	Repeat last sample out the S/PDIF stream
1	Forces midscale sample out the S/PDIF stream	Default
SPAL (S/PDIF ADC Loop Around)	<b>SPAL</b>	<b>S/PDIF Transmitter Source</b>
	0	Connected to the AC-LINK stream
	1	Connected to the digital ADC stream
(CSWP Center/LFE Swap)	Swaps the center/LFE channels. Some systems have a swapped external connection for the center and LFE channels. Setting this bit will swap these channels internal to the codec. The center and LFE controls do not change and remain at the same addresses and bit assignments.	
	<b>CSWP</b>	<b>CENTER Pin</b>
	0	Center channel
1	LFE channel	LFE Pin
		Center channel
		Default

# AD1986A

Register	Function	Default
INTS (Interrupt Mode Select)	This bit selects the audio interrupt implementation path. Note that this bit does not generate an interrupt, rather it steers the path of the generated interrupt.	
	<b>INTS</b>	<b>Interrupt Mode</b>
	0	Bit 0 Slot 12 (modem interrupt) <span style="float: right;">Default</span>
	1	Slot 6 valid bit (MIC ADC interrupt)
LBKS [1:0] Loop-Back Selection	These bits select the internal digital loop-back path when LPBK bit is active (see Register 0x20).	
	<b>LBKS [1:0]</b>	<b>Interrupt Mode</b>
	00	Loop back through the front DACs <span style="float: right;">Default</span>
	01	Loop back through the surround DACs
	10	Loop back through the center and LFE DACs (center DAC loops back from the ADC left channel, the LFE DAC from the ADC right channel)
	11	Reserved
SPOVR (S/PDIF Enable Override)	Use this bit to enable S/PDIF operation even if the external S/PDIF detection resistor is not installed.	
	<b>SPOVR</b>	<b>S/PDIF Detection</b>
	0	External resistor determines the presence of S/PDIF <span style="float: right;">Default</span>
	1	Enable S/PDIF operation
OMS [2:0] Optional Microphone Selector	Selects the source of the microphone gain boost amplifiers. These bits work in conjunction with the 2CMIC (0x76, D06), MS (0x20 D08), and MMIX (0x7A D08) bits.	
	<b>OMS [2:0]</b>	<b>Left Channel</b>
	000	MIC pins <span style="float: right;">Default</span>
	001	LINE_IN pins
	01x	C/LFE pins
	100	Mix of MIC and C/LFE pins
	101	Mix of MIC and LINE_IN pins
	110	Mix of LINE_IN and C/LFE pins
	111	Mix of MIC, LINE_IN and C/LFE pins
REGM [3:0]	Bit mask indicating which codec is being accessed in a chained codec configuration.	
	REGM0—Master codec register mask	Default
	REGM1—Slave 1 codec register mask	
	REGM2—Slave 2 codec register mask	
	REGM3—Slave 3 codec register mask	
SLOT 16	Enable 16-bit slot mode: SLOT16 makes all AC link slots 16 bits in length, formatted into 16 slots. This is a preferred mode for DSP serial port interfacing.	
	<b>SLOT 16</b>	<b>Function</b>
	0	Standard AC '97 operation <span style="float: right;">Default</span>
	1	All ac link S slots are 16 bits
x	Reserved	Default: 0

## MISC CONTROL BITS 1 (REGISTER 0x76)

Reg	Name	D15	D14	D13	D12	D11	D10	D9	D8	D7	D6	D5	D4	D3	D2	D1	D0	Default
0x76	Misc Control Bits 1	DACZ	AC97NC	MSPLT	SODIS	CLDIS	x	DMIX1	DMIX0	SPRD	2CMIC	SOSEL	SRU	LISEL1	LISEL0	MBG1	MBG0	6010

Table 106.

Register	Function															
MBG [1:0] (MIC Boost Gain Select Register)	These two bits allow changing both MIC preamp gain blocks from the nominal 20 dB gain boost. Both MIC_1/2 and MIC_2 preamps will be set to the same selected gain. This gain setting takes affect only while Bit D6 (M20) on the MIC volume register (0x0E) is set to 1, otherwise the MIC boost blocks have a gain of 0 dB.															
	<table border="1"> <thead> <tr> <th>MGB [1:0]</th> <th>Microphone Boost Gain</th> <th>Default</th> </tr> </thead> <tbody> <tr> <td>00</td> <td>20 dB</td> <td>Default</td> </tr> <tr> <td>01</td> <td>10 dB</td> <td></td> </tr> <tr> <td>10</td> <td>30 dB</td> <td></td> </tr> <tr> <td>11</td> <td>Reserved</td> <td></td> </tr> </tbody> </table>	MGB [1:0]	Microphone Boost Gain	Default	00	20 dB	Default	01	10 dB		10	30 dB		11	Reserved	
	MGB [1:0]	Microphone Boost Gain	Default													
	00	20 dB	Default													
01	10 dB															
10	30 dB															
11	Reserved															
LISEL [1:0] (LINE_IN Selector)	Selects the source of the internal LINE_IN signals.															
	<table border="1"> <thead> <tr> <th>LISEL [1:0]</th> <th>LINE_IN Selection</th> <th>Default</th> </tr> </thead> <tbody> <tr> <td>00</td> <td>LINE_IN pins</td> <td>Default</td> </tr> <tr> <td>01</td> <td>SURROUND pins—Places surround outputs in Hi-Z state</td> <td></td> </tr> <tr> <td>1x</td> <td>MIC_1/2 pins</td> <td></td> </tr> </tbody> </table>	LISEL [1:0]	LINE_IN Selection	Default	00	LINE_IN pins	Default	01	SURROUND pins—Places surround outputs in Hi-Z state		1x	MIC_1/2 pins				
	LISEL [1:0]	LINE_IN Selection	Default													
	00	LINE_IN pins	Default													
01	SURROUND pins—Places surround outputs in Hi-Z state															
1x	MIC_1/2 pins															
SRU (Sample Rate Unlock)	Controls all DAC sample rate locking.															
	<table border="1"> <thead> <tr> <th>SRU</th> <th>Surround State</th> <th>Default</th> </tr> </thead> <tbody> <tr> <td>0</td> <td>All DAC sample rates are locked to the front sample rate</td> <td></td> </tr> <tr> <td>1</td> <td>Front, surround, and LFE sample rates can be set independently</td> <td>Default</td> </tr> </tbody> </table>	SRU	Surround State	Default	0	All DAC sample rates are locked to the front sample rate		1	Front, surround, and LFE sample rates can be set independently	Default						
	SRU	Surround State	Default													
0	All DAC sample rates are locked to the front sample rate															
1	Front, surround, and LFE sample rates can be set independently	Default														
SOSEL (Surround Amplifier Input Selection)	Selects either the surround DAC or analog mixer as the source driving the SURROUND output pin amplifier.															
	<table border="1"> <thead> <tr> <th>SOSEL</th> <th>Surround Source</th> <th>Default</th> </tr> </thead> <tbody> <tr> <td>0</td> <td>Surround DACs</td> <td>Default</td> </tr> <tr> <td>1</td> <td>Analog Mixer</td> <td></td> </tr> </tbody> </table>	SOSEL	Surround Source	Default	0	Surround DACs	Default	1	Analog Mixer							
	SOSEL	Surround Source	Default													
0	Surround DACs	Default														
1	Analog Mixer															
2CMIC (2-Channel MIC Select)	Used in conjunction with the OMS [2:0] (0x74 D10:08]), MS (0x20 D08), and MMIX (0x7A D02) bits to set the microphone selection. This bit enables simultaneous recording from MIC_1 and MIC_2 inputs, using a stereo microphone array. If the MMIX (0x7A D02) bit is set, this bit is ignored.															
	<table border="1"> <thead> <tr> <th>2CMIC</th> <th>2 Channel MIC State</th> <th>Default</th> </tr> </thead> <tbody> <tr> <td>0</td> <td>Both outputs are driven by the left channel of the selector</td> <td>Default</td> </tr> <tr> <td>1</td> <td>Stereo operation, the left and right channels are driven separately</td> <td></td> </tr> </tbody> </table>	2CMIC	2 Channel MIC State	Default	0	Both outputs are driven by the left channel of the selector	Default	1	Stereo operation, the left and right channels are driven separately							
	2CMIC	2 Channel MIC State	Default													
	0	Both outputs are driven by the left channel of the selector	Default													
1	Stereo operation, the left and right channels are driven separately															
SPRD (Spread Enable)	This bit enables spreading of 2-channel media to all 6-output channels. This function is implemented in the analog section by using the output selector control lines for the center/LFE, surround, and LINE_OUT output channels. The jack sense pins can also be set up to control (gate) this function, depending on the JSSPRD bit (see Register 0x72). The SPRD bit operates independently and does not affect the LOSEL and HPSEL operation.															
	<table border="1"> <thead> <tr> <th>SPRD</th> <th>Spread State</th> <th>Default</th> </tr> </thead> <tbody> <tr> <td>0</td> <td>No spreading occurs unless activated by jack sense</td> <td>Default</td> </tr> <tr> <td>1</td> <td>The SPDR selector drives the center and LFE outputs from the MONO_OUT</td> <td></td> </tr> </tbody> </table>	SPRD	Spread State	Default	0	No spreading occurs unless activated by jack sense	Default	1	The SPDR selector drives the center and LFE outputs from the MONO_OUT							
	SPRD	Spread State	Default													
	0	No spreading occurs unless activated by jack sense	Default													
1	The SPDR selector drives the center and LFE outputs from the MONO_OUT															
CLDIS (C/LFE Output Enable)	Controls the Hi-Z state of the SURROUND_L/R output pins. Pins are placed into a Hi-Z mode by software control or when they are selected as inputs to the MIC_1/2 selector (see the OMS [2:0] Bits 740x D [10:08]).															
	<table border="1"> <thead> <tr> <th>CLDIS</th> <th>C/LFE Output State</th> <th>Default</th> </tr> </thead> <tbody> <tr> <td>0</td> <td>Outputs enabled</td> <td>Default</td> </tr> <tr> <td>1</td> <td>Outputs tristated</td> <td></td> </tr> </tbody> </table>	CLDIS	C/LFE Output State	Default	0	Outputs enabled	Default	1	Outputs tristated							
	CLDIS	C/LFE Output State	Default													
0	Outputs enabled	Default														
1	Outputs tristated															

# AD1986A

Register	Function		
DMIX [1:0] (DOWN MIX Mode Select)	Provides analog down-mixing of the center, LFE, and/or surround channels into the mixer channels. This allows the full content of 5.1 or quad media to be played through stereo headphones or speakers. The jack sense pins can also be set up to control (gate) this function depending on the JS0DMx and JS1DMx Bits (0x72 D [14:13]).		
	<b>DMIX [1:0]</b>	<b>Down-Mix State</b>	<b>Default</b>
	0x	No down-mix unless activated by jack sense	Default
	10	Selects 6-to-4 down mix. The center and LFE channels are summed equally into the Mixer L/R channels	
	11	Selects 6-to-2 down mix. In addition to the center and LFE channels, the SURROUND channels are summed into the mixer L/R channels	
SODIS (Surround Output Enable)	Controls the Hi-Z state of the SURROUND output pins. Pins are placed into a Hi-Z mode by software control or when they are selected as inputs to the LINE_IN selector (see the LISEL [1:0] bits 0x76 D [03:02]).		
	<b>CLDIS</b>	<b>SURROUND_OUT State</b>	
	0	Outputs enabled	Default
	1	Outputs three-stated (Hi-Z)	
MSPLT (RO) (Mute Split)	Separates the left and right mutes on all volume registers. This bit is read-only 1 (one) on the AD1986A, indicating that mute split is always enabled.		
AC '97NC (RO) (AC '97 No Compatibility Mode)	Changes addressing to ADI model (vs. true AC '97 definition). This bit is read-only 1 (one) on the AD1986A, indicating that ADI addressing is always enabled.		
DACZ (DAC Zero-Fill)	Determines DAC data fill under starved condition.		
	<b>DACZ</b>	<b>DAC Fill State</b>	
	0	DAC data is repeated when DACs are starved for data	Default
	1	DAC data is zero-filled when DACs are starved for data	
x	Reserved.		Default: 0

**ADVANCED JACK SENSE (REGISTER 0x78)**

All register bits are read/write except for JSxST bits, which are read only. **Important:** Refer to Table 116 to understand how JACK\_SENSE\_A and JACK\_SENSE\_B codec pins translate to JS7...JS2.

Reg	Name	D15	D14	D13	D12	D11	D10	D9	D8	D7	D6	D5	D4	D3	D2	D1	D0	Default
0x78	Advanced Jack Sense	JS7 ST	JS7 INT	JS6 ST	JS6 INT	JS5 ST	JS5 INT	JS4 ST	JS4 INT	JS4-7H	x	JS3 MD	JS2 MD	JS3 ST	JS2 ST	JS3 INT	JS2 INT	0xxxxx

Table 107.

Register	Function
JS [7:2] INT	Indicates that JSx has generated an interrupt. Remains set until the software services JSx interrupt; that is, JSx ISR should clear this bit by writing a 0 to it. Interrupts are generated by valid state changes of JSx. Interrupt to the system is actually an OR combination of this bit and JS7 JS0 INT. Interrupt implementation path is selected by the INTS bit (Register 0x74). It is also possible to generate a software system interrupt by writing a 1 to this bit.
<b>JS [7:4] INT</b>	<b>Read</b>
0	JSx logic is not interrupted
1	Sx logic interrupted
	<b>Write</b>
	Clears JSx interrupt
	Generates a software interrupt
JS [7:4] ST (RO)	This bit always reports the logic state of JS7 through JS4 detection logic.
<b>JS [7:4] ST</b>	<b>Jack State</b>
0	No jack present
1	Jack detected
JS [3:2] MD	This bit selects the operation mode for JS2 and JS3.
<b>JS [3:2] MD</b>	<b>Interrupt Mode</b>
0	Jack Sense Mode—jack sense state requires software polling
1	Interrupt Mode—jack sense events will generate interrupts
JS [4–7] Interrupt Mode Select	This bit selects the audio interrupt implementation path (for JS4 to 7). This bit does not generate an interrupt, rather it steers the path of the generated interrupt.
<b>JS4 to 7</b>	<b>Interrupt Mode—JS4 to 7</b>
0	Bit 0 Slot 12 (modem interrupt)
1	Slot 6 valid bit (MIC ADC interrupt)
x	Reserved
	Default: 0

**MISC CONTROL BITS 3 (REGISTER 0x7A)**

Reg	Name	D15	D14	D13	D12	D11	D10	D9	D8	D7	D6	D5	D4	D3	D2	D1	D0	Default
0x7A	Misc Control Bits 3	JSINVB	HPSEL1	HPSEL0	LOSEL	JSINVA	LVREF 2	LVREF1	LVREF 0	x	x	x	LOHPEN	GPO	MMIX	x	x	0x0000

Table 108.

Register	Function
MMIX	Used in conjunction with the OMS [2:0] (0x74 D10:08), MS (0x20 D08), and 2CMIC (0x76 D06) bits to mix the microphone selector left/right channels. If the MMIX bit is set, the 2CMIC and MS bits are ignored.
<b>MMIX</b>	<b>Function</b>
0	Microphone channels are not mixed
1	The left/right channels from the microphone selector are mixed
	Sets the state of the GPO pin
GPO	<b>GPO</b>
0	GPO pin is at logic low (DV <sub>SS</sub> )
1	GPO pin is at logic high (DV <sub>DD</sub> )
	Default

# AD1986A

Register	Function	
LOHPEN	Enables the headphone drive on the LINE_OUT pins. Disabling the headphone drive is the same as powering it down (see the PR6 bit (0x26 D14)).	
	LOHPEN	Function
	0	LINE_OUT headphone drive is disabled Default
	1	LINE_OUT headphone drive is enabled
LVREF [2:0] (Line In VREF_OUT)	Sets the voltage/state of the LINE_IN VREF_OUT signal. VREF_OUT is used to power microphone style devices plugged into the connected jack circuitry. The VREF_OUT pin must be connected to both the left and right channels through external resistors to function properly. Selections other than those defined are invalid and should not be programmed.	
	LINE_IN VREF_OUT Setting	
	LVREF [2:0]	5.0 AV <sub>DD</sub>
	000	Hi-Z Default
	001	2.25 V
	010	0V
	100	3.70 V
LOSEL (LINE_OUT Amplifiers Input Select)	This bit allows the LINE_OUT output amplifiers to be driven by the mixer or the surround DACs. The main purpose for this is to allow swapping of the front and surround channels to make better use of the SURR/HP_OUT output amplifiers. This bit should normally be used in tandem with the HPSEL bit (following in table).	
	LOSEL	LINE_OUT Select
	0	LINE_OUT amplifiers are driven by the analog mixer outputs Default
	1	LINE_OUT amplifiers are driven by the surround DAC
JSINVA Jack Sense Invert	SENSE_A: Select the style of switch used on the audio jacks connected to Sense A.	
	JSINVA	Jack Sense Invert—SENSE_A
	0	SENSE_A configured for normally-open (NO) switches Default
	1	SENSE_A configured for normally-closed (NC) switches
HPSEL [1:0] (Headphone Amplifier Input Select)	This bit allows the headphone power amps to be driven from the surround DACs, C/LFE DACs, or from the mixer outputs.	
	HPSEL [1:0]	HP_OUT Selection
	00	Outputs are driven by the mixer outputs Default
	01	Outputs are driven by the surround DACs
	1x	Outputs are driven by the C/LFE DACs

Register	Function	
JSINVB (Jack Sense Invert)	SENSE_B: Select the style of switch used on the audio jacks connected to Sense B.	
	<b>JSINVB</b>	<b>Jack Sense Invert—SENSE_B</b>
	0	JACK_SENSE_B configured for normally-open (NO) switches Default
1	JACK_SENSE_B configured for normally-closed (NC) switches	
x	Reserved.	Default: 0

### VENDOR ID REGISTERS (REGISTER 0x7C to 0x7E)

Reg	Name	D15	D14	D13	D12	D11	D10	D9	D8	D7	D6	D5	D4	D3	D2	D1	D0	Default
0x7C	Vendor ID 1	F7	F6	F5	F4	F3	F2	F1	F0	S7	S6	S5	S4	S3	S2	S1	S0	0x4144
0x7E	Vendor ID 2	T7	T6	T5	T4	T3	T2	T1	T0	REV7	REV6	REV5	REV4	REV3	REV2	REV1	REV0	0x5378

Table 109.

Register	Function
S [7:0]	This register is ASCII encoded to A.
F [7:0]	This register is ASCII encoded to D.
T [7:0]	This register is ASCII encoded to S.
REV [7:0]	This register is set to 0x78, identifying the AD1986A.

### CODEC CLASS/REVISION REGISTER (REGISTER 0x60)

Reg	Name	D15	D14	D13	D12	D11	D10	D9	D8	D7	D6	D5	D4	D3	D2	D1	D0	Default
0x601	Codec Class/Rev	x	x	x	CL4	CL3	CL2	CL1	CL0	RV7	RV6	RV5	RV4	RV3	RV2	RV1	RV0	0x0002

Table 110.

Register	Function	Default
RV [7:0] (Revision ID: (RO))	These bits specify a device specific revision identifier. The vendor chooses this value. Zero is an acceptable value. This field should be viewed as a vendor defined extension to the codec ID. This number changes with new codec stepping of the same codec ID. This number will increment with each stepping/rev. of the codec chip.	
CL [4:0] (Codec Compatibility Class (RO))	0x00	Field not implemented
	0x01-0x1F	Vendor-specific compatibility class code
x	Reserved.	Default: 0

# AD1986A

## PCI SUBSYSTEM VENDOR ID REGISTER (REGISTER 0x62, PAGE 01)

This register is only reset by power-on. It is used by the BIOS to store configuration information (per AC '97 Revision 2.3 specification) and must not be reset by soft or hardware resets.

Reg	Name	D15	D14	D13	D12	D11	D10	D9	D8	D7	D6	D5	D4	D3	D2	D1	D0	Default
0x621	PCI SVID	PVI15	PVI14	PVI13	PVI12	PVI11	PVI10	PVI9	PVI8	PVI7	PVI6	PVI5	PVI4	PVI3	PVI2	PVI1	PVI0	0xFFFF

Table 111.

Register	Function
PVI [15:0] PCI Sub System Vendor ID	Optional per AC '97 specifications, should be implemented as read/write on AD1986A. This field provides the PCI subsystem vendor ID of the audio or modem subassembly vendor (that is, CNR manufacturer, motherboard vendor). This is not the codec vendor PCI vendor ID or the AC '97 controller PCI vendor ID. If data is not available it returns 0xFFFF.

## PCI SUBSYSTEM DEVICE ID REGISTER (REGISTER 0x64, PAGE 01)

This register is only reset by power-on. It is used by the BIOS to store configuration information (per AC '97 v2.3 specification) and must not be reset by soft or hardware resets.

Reg	Name	D15	D14	D13	D12	D11	D10	D9	D8	D7	D6	D5	D4	D3	D2	D1	D0	Default
0x641	PCI SID	PI15	PI14	PI13	PI12	PI11	PI10	PI9	PI8	PI7	PI6	PI5	PI4	PI3	PI2	PI1	PI0	0xFFFF

Table 112.

Register	Function
PI [15:0] (PCI Vendor ID)	Optional per AC '97 specifications, should be implemented as read/write on the AD1986A. This field provides the PCI subsystem ID of the audio or modem subassembly (that is, CNR model, motherboard SKU). This is not the codec vendor PCI ID or the AC '97 controller PCI ID. Information in this field must be available, because the AC '97 controller reads when the codec ready is asserted in the AC link. If data is not available, it should return 0xFFFF.



**FUNCTION SELECT REGISTER (REGISTER 0x66, PAGE 01)**

This register is used to select which function (analog I/O pins), information and I/O (0x6801), and sense (0x6A01) registers apply to it.

The AD1986A associates FC = 0x0 with surround functions and FC = 0x01 with front functions. These are changed in the AD1986A to align with the device pinout and to separate LINE\_OUT functions.

Reg	Name	D15	D14	D13	D12	D11	D10	D9	D8	D7	D6	D5	D4	D3	D2	D1	D0	Default
0x661	Function Select	x	x	x	x	x	x	x	x	x	x	x	FC3	FC2	FC1	FC0	T/R	0x0000

**Table 113.**

Register	Function																																													
T/R (FIP or Ring Selection Bit)	This bit sets which jack conductor the sense value is measured from. Software will program the corresponding rng/tp selector bit together with the I/O number in bits FC [3:0]. Once software programs the value and properly reads it back to confirm selection and implementation, it will access the rest of the bits fields in the descriptor. Mono inputs and outputs should report the relevant function and sense information when T/R is set to 0 (tip). The FIP bit should report 0 (Page 0x01, Register 0x68, Bit 0 reports no function information present) when T/R is set to a 1 on a mono input or output.																																													
	<table border="1"> <thead> <tr> <th>T/R</th> <th>Function</th> <th>Default</th> </tr> </thead> <tbody> <tr> <td>0</td> <td>Tip (left channel)</td> <td>Default</td> </tr> <tr> <td>1</td> <td>Ring (right channel)</td> <td></td> </tr> </tbody> </table>	T/R	Function	Default	0	Tip (left channel)	Default	1	Ring (right channel)																																					
	T/R	Function	Default																																											
0	Tip (left channel)	Default																																												
1	Ring (right channel)																																													
FC [3:0] Function Code Bits	These bits specify the type of audio function described by this page. These bits are read/write and represent current AC '97 Revision 2.2 defined I/O capabilities. Software will program the corresponding I/O number in this field together with the tip/ring selector bit T/R. Once software programs the value and properly reads it back to confirm selection and implementation, it will access the rest of the bits fields in the descriptor.																																													
	<table border="1"> <thead> <tr> <th>FC [3:0]</th> <th>Function</th> <th>Default</th> </tr> </thead> <tbody> <tr> <td>0x0</td> <td>DAC 1 (master out). maps to front DACs (L/R)</td> <td>Default</td> </tr> <tr> <td>0x1</td> <td>DAC 2 (AUX out). maps to surround DACs (L/R)</td> <td></td> </tr> <tr> <td>0x2</td> <td>DAC 3 (C/LFE). maps to C/LFE DACs</td> <td></td> </tr> <tr> <td>0x3</td> <td>S/P-DIF out</td> <td></td> </tr> <tr> <td>0x4</td> <td>Phone in</td> <td></td> </tr> <tr> <td>0x5</td> <td>MIC_1 (Mic select = 0)</td> <td></td> </tr> <tr> <td>0x6</td> <td>MIC_2 (Mic select = 1)</td> <td></td> </tr> <tr> <td>0x7</td> <td>Line in</td> <td></td> </tr> <tr> <td>0x8</td> <td>CD in</td> <td></td> </tr> <tr> <td>0x9</td> <td>Video in</td> <td>Not supported on the AD1986A</td> </tr> <tr> <td>0xA</td> <td>Aux in</td> <td></td> </tr> <tr> <td>0xB</td> <td>Mono out</td> <td></td> </tr> <tr> <td>0xC</td> <td>Headphone ut</td> <td></td> </tr> <tr> <td>0xD–0xF</td> <td>Reserved</td> <td></td> </tr> </tbody> </table>	FC [3:0]	Function	Default	0x0	DAC 1 (master out). maps to front DACs (L/R)	Default	0x1	DAC 2 (AUX out). maps to surround DACs (L/R)		0x2	DAC 3 (C/LFE). maps to C/LFE DACs		0x3	S/P-DIF out		0x4	Phone in		0x5	MIC_1 (Mic select = 0)		0x6	MIC_2 (Mic select = 1)		0x7	Line in		0x8	CD in		0x9	Video in	Not supported on the AD1986A	0xA	Aux in		0xB	Mono out		0xC	Headphone ut		0xD–0xF	Reserved	
	FC [3:0]	Function	Default																																											
	0x0	DAC 1 (master out). maps to front DACs (L/R)	Default																																											
	0x1	DAC 2 (AUX out). maps to surround DACs (L/R)																																												
	0x2	DAC 3 (C/LFE). maps to C/LFE DACs																																												
	0x3	S/P-DIF out																																												
	0x4	Phone in																																												
	0x5	MIC_1 (Mic select = 0)																																												
	0x6	MIC_2 (Mic select = 1)																																												
	0x7	Line in																																												
	0x8	CD in																																												
	0x9	Video in	Not supported on the AD1986A																																											
0xA	Aux in																																													
0xB	Mono out																																													
0xC	Headphone ut																																													
0xD–0xF	Reserved																																													
x	Reserved. Default: 0																																													

## INFORMATION AND I/O REGISTER (REGISTER 0x68, PAGE 01)

This address represents multiple registers (one for each supported function code (FC [3:0] bits (0x66 D [04:01])). These values are only reset by power-on. It is used by the BIOS to store configuration information (per AC '97 Revision 2.3 specifications) and must not be reset by soft or hardware resets.

Reg	Name	D15	D14	D13	D12	D11	D10	D9	D8	D7	D6	D5	D4	D3	D2	D1	D0	Default
0x681	Information and I/O	G4	G3	G2	G1	G0	INV	DL4	DL3	DL2	DL1	DL0	IV	x	x	x	FIP	0xxxxx

Table 114.

Register	Function		
FIP (RO) (Function Information Present)	codec default. When set to a 1, this bit indicates that the G [4:0], INV, DL [4:0] (in Register 0x681), and ST [2:0] (in Register 0x6A1) bits are supported and are read/write capable. This bit set to a 0 indicates that the G [4:0], INV, DL [4:0], and ST [2:0] bits are not supported, and are read-only with a value of 0. Mono inputs and outputs report the relevant function and sense information when T/R is set to 0 (tip). The FIP bit reports a 0 (Page 0x01, Register 0x68, Bit 0 reports no function information present) when T/R is set to a 1 on a mono input or output.		
	<b>FIP</b>		
	<b>Function</b>		
	0	Function information not supported	Power-on default
	1	Function information supported	
IV (Information Valid Bit)	Indicates whether a sensing method is provided by the codec and if information field is valid. This field is updated by the codec.		
	<b>IV</b>		
	<b>Function</b>		
	0	After codec reset de-assertion, it indicates the codec does not provide sensing logic and this bit will be read-only. A completed sense cycle indicates that no information is provided on the sensing method.	
	1	After codec reset de-assertion, it indicates the codec provides sensing logic for this I/O and this bit is read/write. After clearing this bit by writing 1, when a sense cycle is completed indicates that there is valid information in the remaining descriptor bits. Writing 0 to this bit has no effect.	
DL [4:0] (Buffer Delays, Read/Write)	A number representing a delay measurement for the input and output channels. The default value is the delay internal to the codec. The BIOS can add to this value the known delays external to the codec, such as for an external amplifier or logic. Software will use this value to accurately calculate audio stream position with respect to what is been reproduced or recorded. These values are in 20.83 microsecond (1/48000 second) units. For output channels, this timing is from the end of AC link frame in which the sample is provided, until the time the analog signal appears at the output pin. For input streams, this is from when the analog signal is presented at the pin until the representative sample is provided on the AC link. Analog to analog paths are not considered in this measurement. The measurement is a typical measurement, at a 48 kHz sample rate, with minimal in-codec processing (that is, 3D effects are turned off.) An example of an audio output delay is filter group delay and FIFO or other sample buffers in the path. When an audio PCM sample is written to the codec in an AC '97 frame it will be delayed before the output pin is updated to that value.		
	<b>DL [4:0]</b>		
	<b>Function</b>		
	0x00	Information not provided	
	0x01-0x1E	Buffer delay: 20.83 $\mu$ s per unit	
	0x1F	Reserved	
INV (Inversion Bit, Read/Write, Codec Default)	Indicates that the codec presents a 180° phase shift to the signal. This bit is only reset by a power-on reset, since it is typically written by the system BIOS and is not reset by codec hard or soft resets as long as power remains applied to the codec.		
	<b>INV</b>		
	<b>Function</b>		
	0	No phase shift	
	1	Signal is shifted by 180° from the source signal	

Register	Function	
G [4:0] (Gain Bits (Read/Write))	The codec updates these bits with the gain value (dB relative to level-out) in 1.5 dBV increments, not including the volume control gains. For example, if the volume gain is to 0 dB, then the output pin should be at the 0 dB level. Any difference in the gain is reflected here. When relevant, the BIOS updates this bit to take into consideration external amplifiers or other external logic that it knows about. G [3:0] indicates the magnitude of the gain. G [4] indicates whether the value is a gain or attenuation—essentially it is a sign bit. These bits are only reset by a power-on reset because they are typically written by the system BIOS and are not reset by codec hard or soft resets as long as power remains applied to the codec.	
	<b>G4</b>	<b>G [3:0]</b>
	0	0000
	0	0001 ... 1111
	1	0001 ... 1111
	x	Reserved
		<b>Gain/Attenuation (dB Relative to Level-Out)</b>
		0 dB
		+1.5 dB +1.5 dB × G [3:0] +24.0 dB
		-1.5 dB -1.5 dB × G [3:0] -24.0 dB
		Default: 0

### SENSE REGISTER (REGISTER 0x6A, PAGE 01)

This address represents multiple registers (one for each supported function code (FC [3:0] bits (0x66 D [04:01])). The ST [2:0] bits are only reset by power-on. They are used by the BIOS to store configuration information (per AC '97 Revision 2.3 specifications) and must not be reset by soft, hard, or hardware resets. The remaining bits are the result of the last sense operation performed by the impedance sensing circuitry.

Reg	Name	D15	D14	D13	D12	D11	D10	D9	D8	D7	D6	D5	D4	D3	D2	D1	D0	Default
0x6A1	Sense Register	ST2	ST1	ST0	S4	S3	S2	S1	S0	OR1	OR0	SR5	SR4	SR3	SR2	SR1	SR0	0xxxxx

Table 115.

Register	Function		Default
SR [5:0] (RO) (Sense Result Bits, RO)	These bits are used to report a vendor specific fingerprint or value (resistance, impedance, or reactance). Used with the OR bits which are the multiplying factor.		Default: 0
OR [1:0] (RO) (Order Bits)	These bits indicate the order the sense result bits SR [5:0] are using. For example, if measuring resistance SR = 1/OR = 11: the result is 1 kΩ.		
	<b>OR [1:0]</b>	<b>Order Value</b>	
	00	10 <sup>0</sup> —SR bits indicate the actual impedance in ohms	Default
	01	10 <sup>1</sup> —SSR bits indicate the impedance in ohms × 10	
	10	10 <sup>2</sup> —SR bits indicate the impedance in ohms × 100	
	11	10 <sup>3</sup> —SSR bits indicate the impedance in ohms × 1,000	
S [4:0] (RO)	Sensed bits meaning relates to the I/O being sensed as input or output. Read-only. Sensed bits (when output sense cycle initiated). This field allows for the reporting of the type of output peripheral/device plugged in the jack. Values specified below should be interrogated with the SR [5:0] and OR [1:0] for accurate reporting.		
	<b>S [4:0]</b>	<b>Sense Value</b>	
	0x00	Data not valid. Indicates that the reported value(s) is invalid	
	0x01	No connection. Indicates that there are no connected devices	Default
	0x02	Indicates a specific fingerprint value for devices that are not specified or are unknown	
	0x03	Speakers (8 Ω)	
	0x04	Speakers (4 Ω)	
	0x05	Powered speakers	
	0x06	Stereo headphone	
	0x07	SPDIF out (electrical)	
	0x08	SPDIF out (TOS)	

# AD1986A

Register	Function		Default
	0x09	Mono headset (mono speaker left channel and mic. Read Functions 5 and 6 for matching microphone)	
	0x0A	Allows a vendor to report sensing other type of devices/peripherals. SR [5:0] together with OR [1:0] provide information regarding the type of device sensed	
	0x0B–0x0E	Reserved	
	0x0F	Unknown (use fingerprint)	
	0x10–0x1F	Reserved	
S [4:0] (RO)	Sensed bits (when input sense cycle initiated). This field allows for the reporting of the type of input peripheral/device plugged in the jack. Specified values should be interrogated with the SR [5:0] and OR [1:0] bits for accurate reporting.		
	<b>ST [2:0]</b>	<b>Sense Value</b>	
	0x10	Data not valid. Indicates that the reported value(s) is invalid	
	0x11	No connection. Indicates that there are no connected devices	Default
	0x12	Indicates a specific fingerprint value for devices that are not specified or are unknown	
	0x13	Microphone (mono)	
	0x14	Microphone (stereo)	
	0x15	Stereo line in (CE device attached)	
	0x16	Mono line in (CE device attached)	
	0x17	SPDIF In (electrical)	
	0x18	SPDIF In (TOS)	
	0x19	Headset (mono speaker left channel and mic.) Read Functions 0 to 3 for matching DAC out	
	0x1A	Allows a vendor to report sensing other types of devices/peripherals. SR [5:0] together with OR [1:0] provide information regarding the type of device sensed	
	0x1B–0x1E	Reserved	
	0x1F	Unknown (use fingerprint)	
ST [2:0] (Connector/Jack location Bits, Read/Write)	This field describes the location of the jack in the system. This field is updated by the BIOS. These bits are only reset by a power-on reset because it is typically written by the system BIOS and is not reset by codec hard or soft resets as long as power remains applied to the codec.		
	<b>ST [2:0]</b>	<b>Jack Location</b>	
	0x0	Rear I/O panel	Power-on default
	0x1	Front panel	
	0x2	Motherboard	
	0x3	Dock/external	
	0x4–0x6	Reserved	
	0x7	No connection/unused I/O	

## JACK PRESENCE DETECTION

The AD1986A uses two jack sense lines for presence detection on up to eight external jacks. These lines, combined with the device detection circuitry, enable software to determine whether there is a device plugged into the circuit and what type of device it is. With this feature, software can reconfigure jacks and amplifiers as necessary to ensure proper audio operation.

Jack presence is detected using a resistor tree arrangement. Up to four jacks can be sensed on a single sense line by using a different value resistance for each jack between the sense line and ground ( $AV_{SS}$ ). Each sense line must have a single 2.49 k $\Omega$  1% resistor connected between the sense line and  $AV_{DD}$ . The specific resistor values for each jack are shown in Table 116. One percent tolerance resistors should be used for all jack presence circuitry to ensure accurate detection.

### AUDIO JACK STYLES (NC/NO)

The jack sense lines on the AD1986A can be programmed for use with normally-open (NO) or normally closed (NC) switch types. Current standard stereo audio jacks have wrap-back pins that are normally closed. New audio jacks use isolated, normally open switches, which are required for resistive ladder jack presence detection. Each sense group (A or B) must have the same style of jack for presence detection to function correctly. However, the group (A or B) sense type can be programmed separately to accommodate systems with different styles of jacks on the front versus rear panel.

The AD1986A defaults to the isolated, normally open switch types on power-up. The jack sense style for SENSE\_A is controlled by the JSINVA bit (Register 0x7A Bit D11). The jack

sense style for SENSE\_B is controlled by the JSINVB bit (Register 0x7A Bit D15). Writing a 1 to these bits will configure the corresponding sense circuit for normally closed instead of normally open switch types.

Wrap-back jacks cannot be used in microphone-capable circuits. For this reason isolated switches are recommended. The codec defaults to sensing No style switches and this method is preferred.

### Normally-Open Switches

If a connection is not present, do not install the sense resistor pertaining to that connection.

If a connection is present, but there is no related switch (such as an internal connection), install the sense resistor pertaining to that connection.

### Normally Closed Switches

Connections capable of MIC bias require isolated switches to function correctly. When using normally closed, wrap-back switches, the jack resistor must be split into two values. One value connects the sense line to the jack switch and the other connects the related audio connection to  $AV_{SS}$ . The total resistance (sense line to  $AV_{SS}$ ) must equal the value specified in Table 116.

If a connection is not present, install the sense resistors pertaining to that connection.

If a connection is present, but there is no related switch (such as an internal connection), do not install the sense resistors pertaining to that connection.

**Table 116. Jack Sense Mapping**

Resistor (1% tolerance)	JACK_SENSE_A			JACK_SENSE_B		
	Mnemonic	Jack	JS	Mnemonic	Jack	JS
4.99 k $\Omega$		D	JS7	LINE OUT	H	JS0
10.0 k $\Omega$	LINE IN	C	JS4	C/LFE	G	JS3
20.0 k $\Omega$	MIC_1/2	B	JS5	SURROUND	F	JS2
40.2 k $\Omega$	HP_OUT	A	JS1	AUX IN	E	JS6

# MICROPHONE SELECTION/MIXING

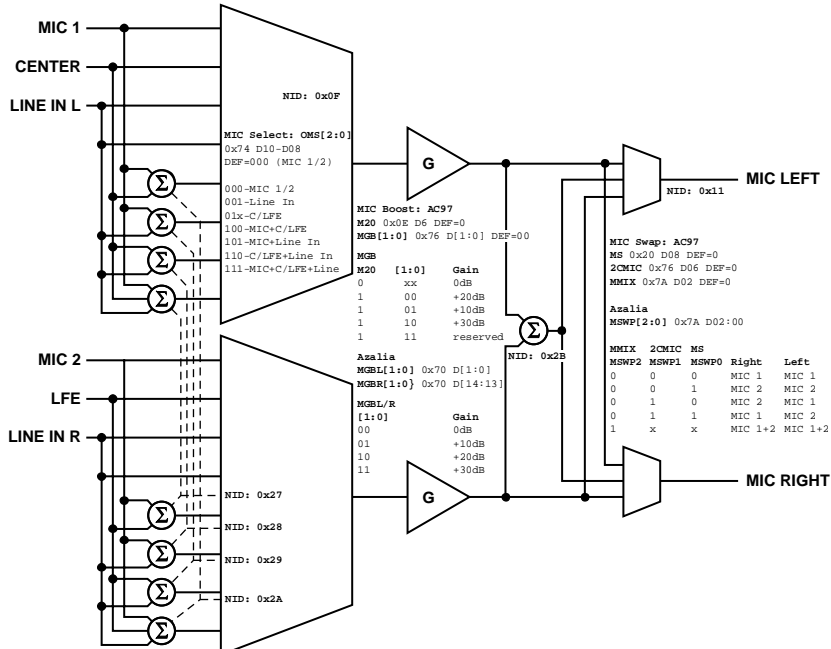
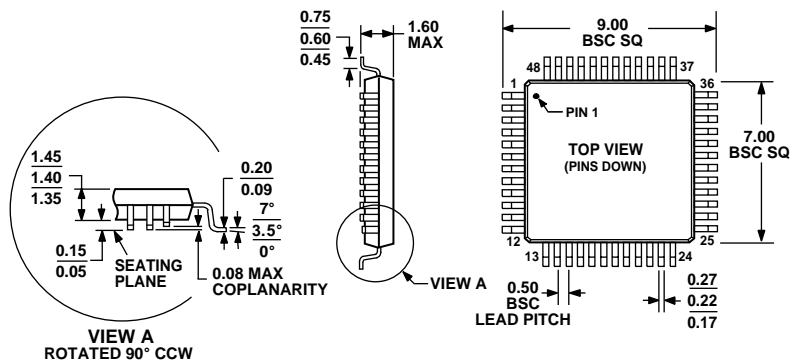

Figure 3. Microphone Selection/Mixing Block Diagram

04785-003

## OUTLINE DIMENSIONS



COMPLIANT TO JEDEC STANDARDS MS-026-BBC

Figure 4. 48-Lead Low Profile Quad Flat Package [LQFP] (ST-48)

Dimensions shown in millimeters

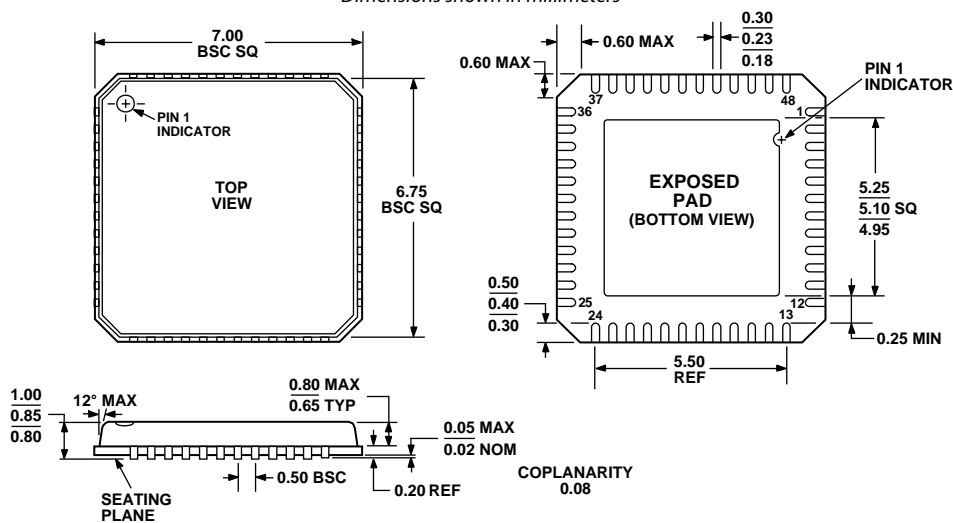

COMPLIANT TO JEDEC STANDARDS MO-220-VKGD-2

Figure 5. 48-Lead Lead Frame Chip Scale Package [LFCSP\_VQ] 7 x 7 mm Body, Very Thin Quad (CP-48-1)

Dimensions shown in millimeters

## ORDERING GUIDE

Model	Temperature Range	Package Description	Package Option
AD1986AJSTZ <sup>1</sup>	0°C to 70°C	48-Lead LQFP, Tray	ST-48
AD1986AJSTZ-REEL <sup>1</sup>	0°C to 70°C	48-Lead LQFP, Reel	ST-48
AD1986ABSTZ <sup>1</sup>	-40°C to +85°C	48-Lead LQFP, Tray	ST-48
AD1986ABSTZ-REEL <sup>1</sup>	-40°C to +85°C	48-Lead LQFP, Reel	ST-48
AD1986AJCP	0°C to 70°C	48-Lead LFCSP_VQ, Tray	CP-48-1
AD1986AJCP-RL	0°C to 70°C	48-Lead LFCSP_VQ, Reel	CP-48-1
AD1986AJCPZ <sup>1</sup>	0°C to 70°C	48-Lead LFCSP_VQ, Tray	CP-48-1
AD1986AJCPZ-RL <sup>1</sup>	0°C to 70°C	48-Lead LFCSP_VQ, Reel	CP-48-1

<sup>1</sup> Z = Pb-free part.

**AD1986A**

**NOTES**