

4

3

2

1

NOTES:

1. WINCHESTER ELECTRONICS NOMENCLATURE ARE ENCLOSED IN BRACKETS [] WHERE NECESSARY TO ENSURE CATALOG NUMBER DOES NOT EXCEED 15 DIGITS

ORDERING INFORMATION

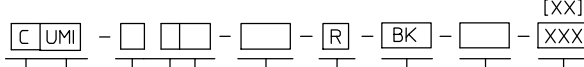

C-OPTIONAL CLOSED ENTRY SOCKET CONTACT NO DESIGNATOR- STANDARD OPEN ENTRY CONTACTS

UMI SERIES DESIGNATOR MICRO-MINATURE RACK AND PANEL, 22 AWG CONTACTS, #030

NUMBER OF CONTACTS SPECIFY: 4, 5, 7, 9, 11, 14, 20, 26, 29, 34, 44, 50, OR MS50

CONTACT TYPE DESIGNATOR M- MALE PIN, SOLDER CUP, (PHOS. BRONZE)- STD. (M28748) F- FEMALE SOCKET, SOLDER CUP, (PHOS. BRONZE)- STD. [UMI]- F- FEMALE SOCKET, SOLDER CUP, CLOSED ENTRY PHOS BRONZE- (M28748) BF- FEMALE SOCKET, SOLDER CUP, BERYLLIUM COPPER- OPTIONAL

OPTIONAL CONTACT TERMINATION DESIGNATORS D07 [D1] - #023 DIP SOLDER TAIL X .070 IN LONG DD13 [D5] - #030 DIP SOLDER TAIL X .125 IN LONG D09 [D2] - #023 DIP SOLDER TAIL X .093 IN LONG DD16 [D6] - #030 DIP SOLDER TAIL X .156 IN LONG D14 [D3] - #023 DIP SOLDER TAIL X .140 IN LONG DD31 [D7] - #030 DIP SOLDER TAIL X .310 IN LONG D18 [D4] - #023 DIP SOLDER TAIL X .180 IN LONG WWS4 [W1] - #025 IN SQ NON ROTATING WIRE WRAP TAIL X .540 IN LONG

SPECIAL VARIATION OF STANDARD SERIES CONSULT FACTORY * FSC [FC] = SOLDER FILLED CUPS

CONTACT PLATING VARIATION BLANK [A] - STANDARD GOLD FLASH WILL BE SUPPLIED UNLESS OTHERWISE SPECIFIED. 30 [B] - .000030 IN. GOLD 50 [C] - .000050 IN. GOLD (PER M28748)

OPTIONAL REINFORCEMENT MTG BRACKET BK = DESIGNATOR *TO ORDER BRACKETS SEPARATELY SPECIFY SERIES, NO OF CONTACTS & BK (i.e. UMI-29BK)

OPTIONAL HARDWARE POLARIZATION R - REVERSED HARDWARE DESIGNATOR 2M [M] - 2 MALE GUIDES, SCREWLOCKS OR JACKSCREWS 2F [F] - 2 FEMALE GUIDES, SCREWLOCKS OR JACKSCREWS

HARDWARE VARIATIONS

CONNECTOR WITHOUT HARDWARE W= NO HARDWARE (i.e. UMI-14M-W)

POLARIZED GUIDES: BLANK [G]- STANDARD POLARIZED GUIDES (BRASS, GOLD FLASH FINISH) WILL BE SUPPLIED UNLESS OTHERWISE SPECIFIED SS = STAINLESS STEEL POLARIZED GUIDES .150 MTG. STUD EXTENSION SS25 [SS2]- STAINLESS STEEL POLARIZED GUIDES .250 MTG. STUD EXTENSION- (PER MIL-28748)

POLARIZED GUIDES WITH HOOD & CABLE CLAMP: (UNAVAILABLE FOR SIZE 4 ONLY) HR- TOP OPENING HOOD WITH STANDARD POL. GUIDES (BRASS, GOLD FLASH) HS- SIDE OPENING HOOD WITH STANDARD POL. GUIDES (BRASS, GOLD FLASH) SSHR [SHR]- TOP OPENING HOOD WITH STAINLESS STEEL GUIDES .150 MTG. STUD EXTENSION SSSH [SSH]- SIDE OPENING HOOD WITH STAINLESS STEEL GUIDES .150 MTG. STUD EXTENSION. WHR- TOP OPENING HOOD & CABLE CLAMP-ORDERED SEPARATELY-WITHOUT HDWE. (i.e. UMI-14-WHR) WHS- SIDE OPENING HOOD & CABLE CLAMP-ORDERED SEPARATELY-WITHOUT HDWE. (i.e. UMI-14-WHS)

LONG TURNABLE SCREWLOCKS WITH HOOD & CABLE CLAMP (HARDWARE USED WITH HOODS ONLY) *KHR [KT]- TOP OPENING HOOD WITH 2-56 THD STAINLESS STEEL SCREWLOCKS- PER MIL-28748 *KHS [KS]- SIDE OPENING HOOD WITH 2-56 THD STAINLESS STEEL SCREWLOCKS- PER MIL-28748 WKHR [WT]- TOP OPENING HOOD & CABLE CLAMP-ORDERED SEPARATELY-WITHOUT HDWE (i.e. UMI-14-WKHR [UMI-14-WT]) WKHS [WS]- SIDE OPENING HOOD & CABLE CLAMP-ORDERED SEPARATELY-WITHOUT HDWE (i.e. UMI-14-WKHS [UMI-14-WS]) *KH [KH]- LONG TURNABLE JACKSCREWS (2-56 THD STAINLESS STEEL) USED WITH HOODS ONLY- ORDERED SEPARATELY-(WHEN ORDERING SPECIFY SERIES AND HOOD SIZE, i.e. UMI-5-1KH [UMI-5-KH])

FIXED SCREWLOCKS-CHASSIS MTG 1SL [SL1]- 2-56 THD (STAINLESS STEEL- .150 MTG. STUD EXT.) 2SL [SL2]- 3-48 THD (STAINLESS STEEL- .150 MTG. STUD EXT.) 1SL25 [SL3]- 2-56 THREAD (STAINLESS STEEL- .250 MTG. STUD EXT.)-PER MIL-28748 2SL25 [SL4]- 3-48 THREAD (STAINLESS STEEL- .250 MTG. STUD EXT.)

SHORT TURNABLE SCREWLOCKS: 1K [K]- 2-56 THD (STAINLESS STEEL HARDWARE & KNOB)- PER MIL-28748 1KL [KL]- 2-56 THD, SHORT SLOTTED-KNOBLESS (STAINLESS STEEL) 2KL [KL2]- 3-48 THREAD, SHORT SLOTTED-KNOBLESS (STAINLESS STEEL) 1K15 [K15]- 2-56 THD SHORT SLOTTED KNOB #16 X .28 LONG (STAINLESS STEEL) 1K16 [K16]- 2-56 THD SHORT SLOTTED KNOB #19 X .32 LONG (STAINLESS STEEL) 1K17 [K17]- 2-56 THD 094 HEX SOCKET KNOB #16 X .24 LONG (STAINLESS STEEL) 1K18 [K18]- 2-56 THD 094 HEX SOCKET KNOB #19 X .30 LONG (STAINLESS STEEL) 1K19 [K19]- 2-56 THD SHORT SLOTTED KNOB #16 X .23 LONG (STAINLESS STEEL) 1K21 [K21]- 2-56 THD .078 HEX SOCKET KNOB #12 X .20 LONG (STAINLESS STEEL) 1K24 [K24]- 2-56 THD .094 HEX SOCKET KNOB #16 X .16 LONG (STAINLESS STEEL) 2K15 [K25]- 3-48 THD SHORT SLOTTED KNOB #16 X .28 LONG (STAINLESS STEEL) 2K16 [K26]- 3-48 THD SHORT SLOTTED KNOB #19 X .32 LONG (STAINLESS STEEL) 2K17 [K27]- 3-48 THD SHORT SLOTTED KNOB #16 X .24 LONG (STAINLESS STEEL) 2K18 [K28]- 3-48 THD SHORT SLOTTED KNOB #19 X .30 LONG (STAINLESS STEEL)

D

D

C

C

B

B

A

A

Table with columns: REV, DATE, DESCRIPTION, REVISED & REDRAWN BY, DATE, UJI

Table with columns: PER ANSI Y14.5M-1982 UNLESS OTHERWISE SPECIFIED DIMENSIONS ARE IN INCHES, TOLERANCES, DECIMALS .XX ± .XXX ±, ANGLES ±, SCALE, MATERIAL, FINISH, DRAWN, DATE, CHECKED, DATE, APPROVED, DATE

Winchester Electronics logo and address: 400 Park Road Waterbury, Connecticut 06705. Composite Outline Assy. UMI- 0 M/F CONNECTOR. Part number 093008, sheet 1 of 4.

4

3

2

1

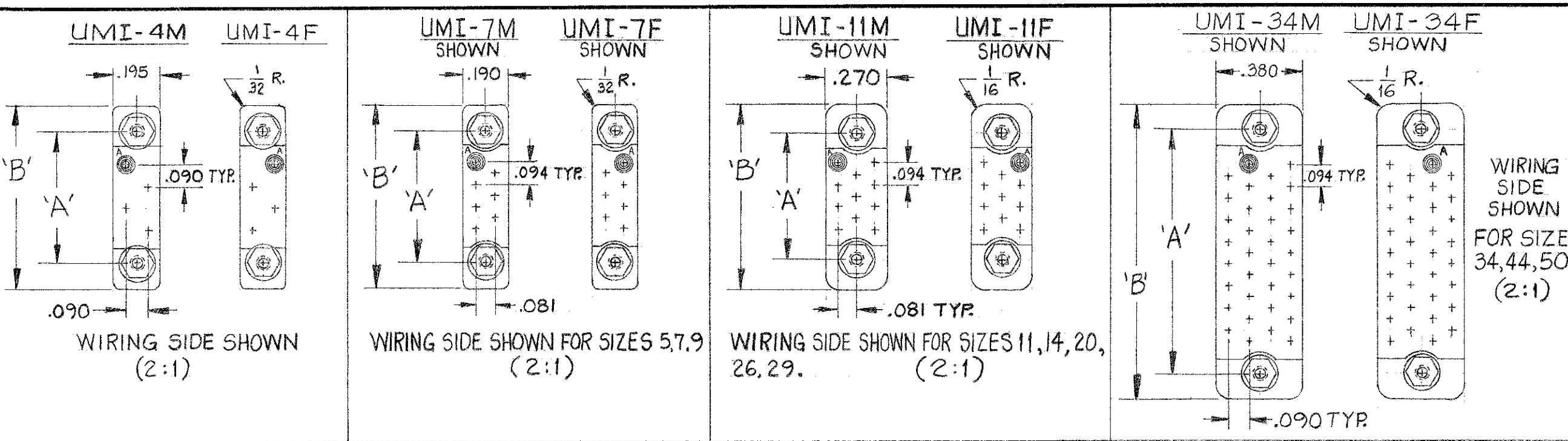

SIZE	'A'	'B'	'C'	'D' ^{+0.010} _{-.000}
4	.562	25/32	.195	.468
5	.468	11/16	.190	.375
7	.562	25/32	.190	.468
9	.656	7/8	.190	.562
11	.532	25/32	.270	.438
14	.625	7/8	.270	.531
20	.814	1 1/16	.270	.720
26	1.000	1 1/4	.270	.906
29	1.094	1 1/32	.270	1.000
34	1.032	1 1/4	.380	.938
44	1.281	1 1/2	.380	1.187
50	1.408	1 5/8	.380	1.314

WIRING SIDE SHOWN FOR SIZES 34, 44, 50 (2:1)

REVISIONS			
SYM.	DESCRIPTION	DATE	APP'D.
E	SEE SHEET 1	11/5/93	JLL

RECOMMENDED PANEL CUT-OUTS

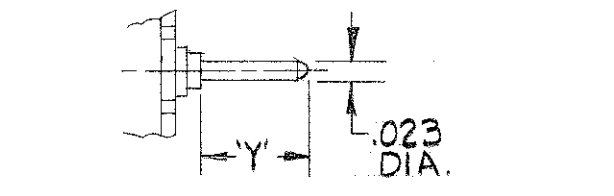
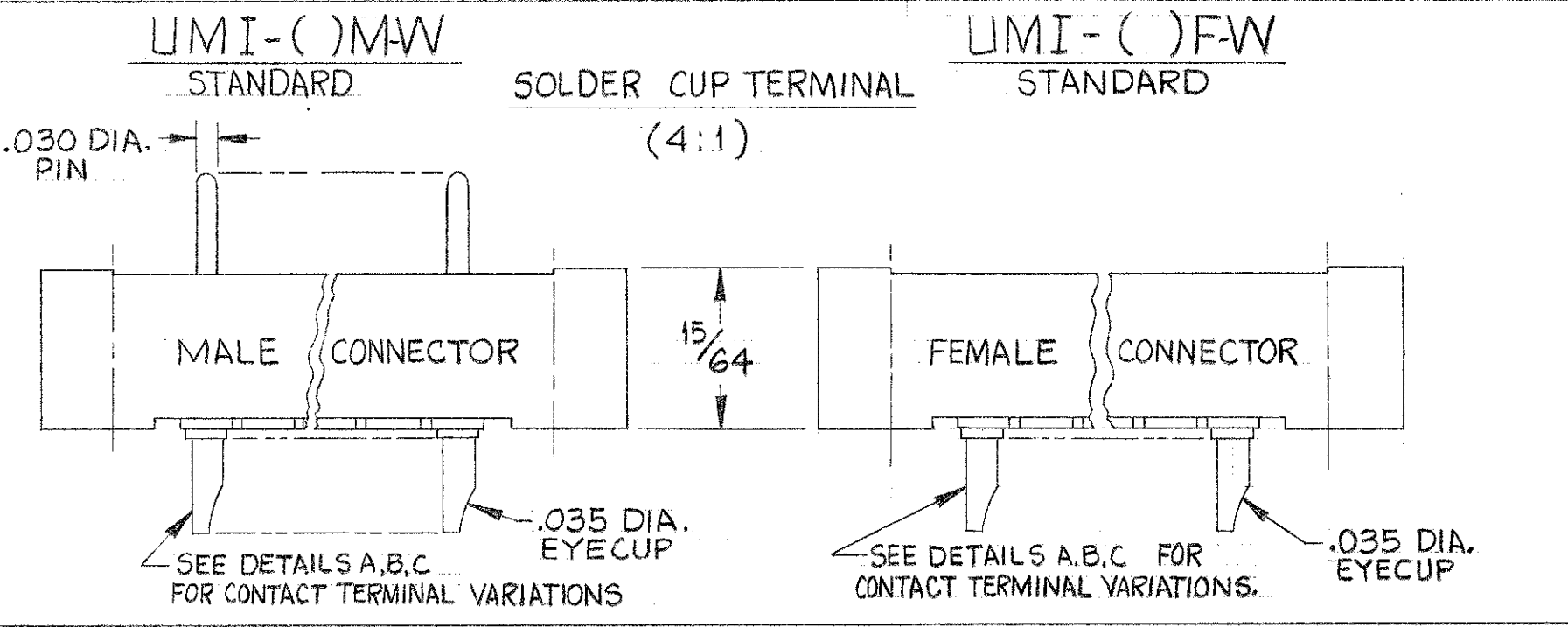
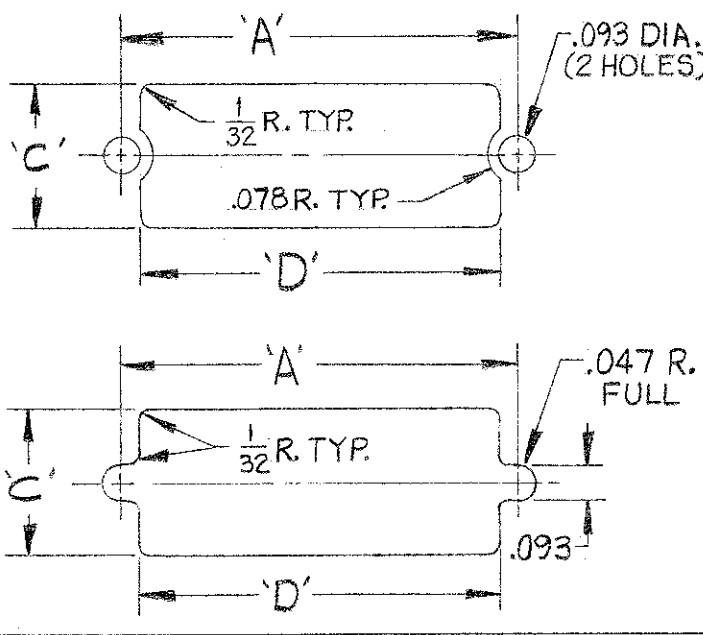

DIP SOLDER TERMINAL
DETAIL A (4:1)

TYPE	DIM. 'Y'
DD7	.065
DD14	.140
DD18	.180

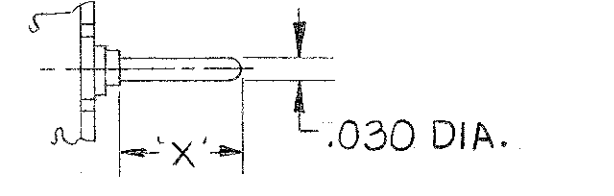

DIP SOLDER TERMINAL
DETAIL B (4:1)

TYPE	DIM. 'X'
DD13	.125
DD16	.156
DD31	.310

NOTES:

- 1-MATERIAL & FINISHES:
 MOLDING - DIALLYL PHTHALATE PER MIL-M-14, TYPE 5DG-F.
 CONTACTS - SPRING TEMPER PHOSPHOR BRONZE PER QQ-B-750, GOLD PLATED OVER COPPER OR BERYLLIUM COPPER PER QQ-C-530, GOLD PLATED OVER COPPER.
 'C' WASHER - SPRING TEMPER PHOSPHOR BRONZE PER QQ-B-750, GOLD PLATED OVER COPPER.
 SCREWLOCKS, NUTS, WASHERS - STAINLESS STEEL NON-MAGNETIC, PASSIVATED.
 GUIDES - BRASS ASTM B16, GOLD PLATED OVER COPPER OR STAINLESS STEEL #303, PASSIVATED.
 HOODS & C. CLAMPS, BRACKET - ALUMINUM, ANODIZED PER MIL-M-8625A.
 KNOBS, SET SCREWS, NUTS - STEEL, CADMIUM PLATED PER QQ-P-416, IRIDESCENT GOLD COLOR.
 RET. RING - BRASS PER QQ-B-626, NICKEL PLATED.
 C.C. SCREWS - BRASS, CADMIUM PLATED PER QQ-P-416, IRIDESCENT GOLD COLOR.
 LOCKWASHER - PHOSPHOR BRONZE, CADMIUM PLATED PER QQ-P-416, IRIDESCENT GOLD COLOR.

- 2-ELECTRICAL SPECIFICATIONS:
 CONTACT SIZE - NO. 22 (.030 DIA.) ACCOMMODATES NO. 22 A.W.G. WIRE.
 CONTACT RATING - 5 AMPS.
 CREEPAGE PATH BETWEEN CONTACTS - 1/16 MIN.
 AIR SPACE BETWEEN CONTACTS - .031 MIN.

	TEST VOLTAGE	WORKING VOLTAGE
SEA LEVEL	1000 VOLTS A.C. RMS.	490 VOLTS D.C.
70,000	300 VOLTS A.C. RMS.	125 VOLTS D.C.

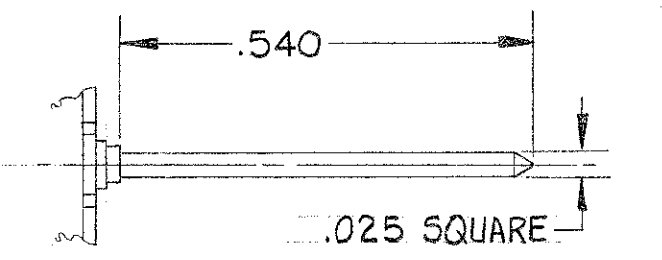

WIRE WRAP TERMINAL
DETAIL 'C' (4:1)

EFFECTIVE APRIL 21, 1989 THIS DRAWING BECAME THE PROPERTY OF LITTON SYSTEMS, INCORPORATED WINCHESTER ELECTRONICS DIVISION 400 PARK RD., WATERTOWN, CT 06795

THIS DRAWING, THE DESIGNS, AND IDEAS EMBODIED IN THE DEVICE TO WHICH IT RELATES, AND THE METHODS OF PRODUCING THE DEVICE ARE THE PROPERTY OF U. S. COMPONENTS, INC. AND SHALL NOT BE EMPLOYED, COPIED, OR DISCLOSED TO ANYONE, IN ANY MANNER WITHOUT THE CONSENT OF U. S. COMPONENTS, INC.

NEXT ASS'Y	USED ON
APPLICATION	
TOLERANCES UNLESS OTHERWISE SPECIFIED	SCALE
DECIMALS ± .005	AS NOTED
FRACTIONS ± 1/64	
ANGULAR ±	

U.S. COMPONENTS INC.
 35 CARLOUGH ROAD BOHEMIA, N.Y. 11716

TITLE: COMPOSITE OUTLINE ASSY, UMI-() M/F CONNECTOR

MATERIAL	DRAWN BY: JLL	DATE: 3/8/87
FINISH	APP'D. BY: JLL	DATE: 4/24/87
SCALE	DRAWING NUMBER	REV.
AS NOTED	093008 SH.2 OF 4	E

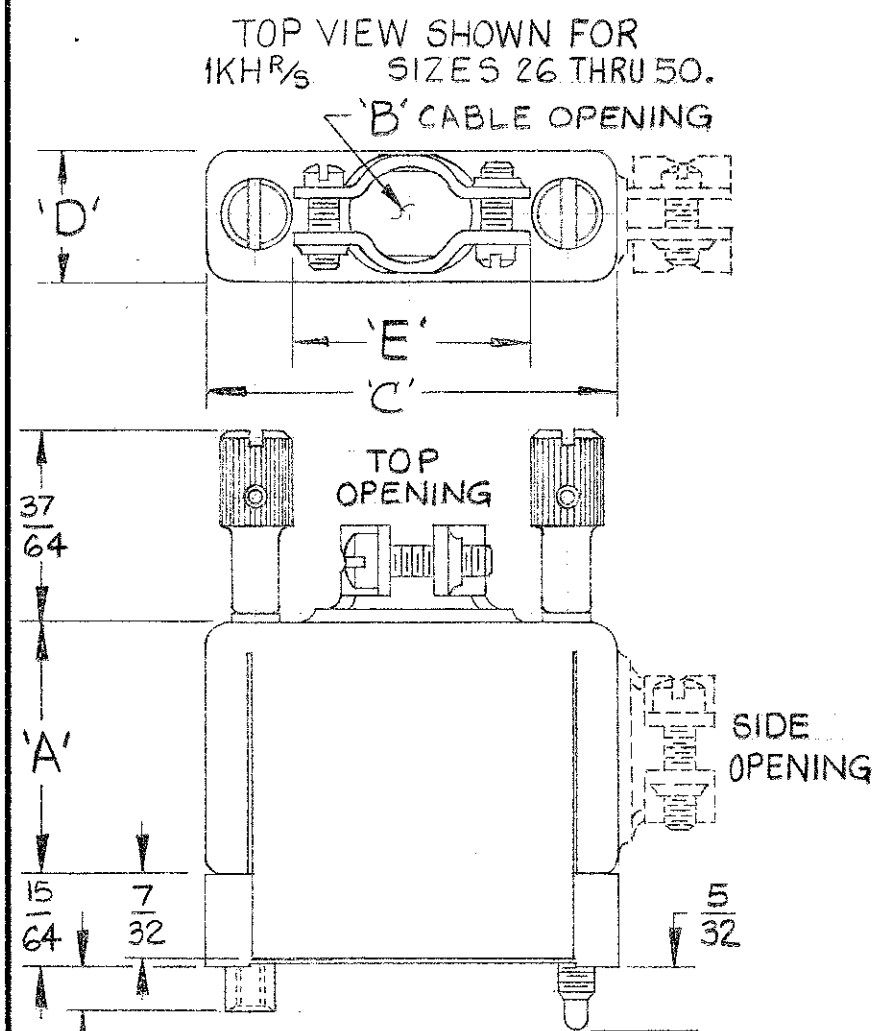

TYPE IKHR_s
LONG TURNABLE SCREWLOCKS WITH HOOD & CABLE CLAMP (2:1)

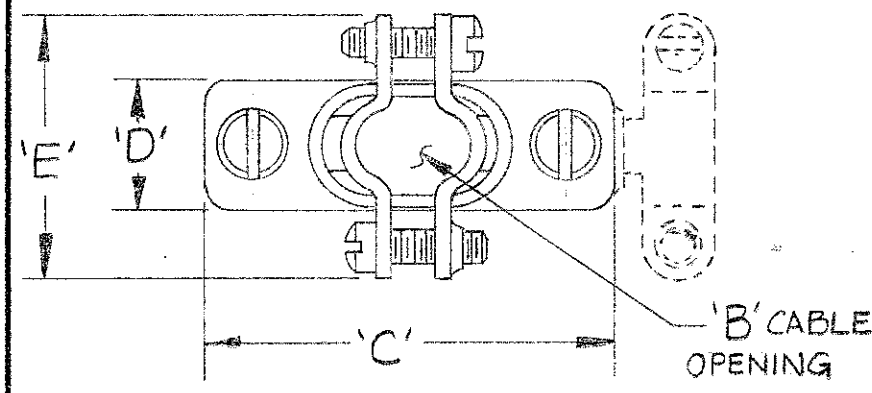

TOP VIEW SHOWN FOR IKHR_s SIZES 5 THRU 20.

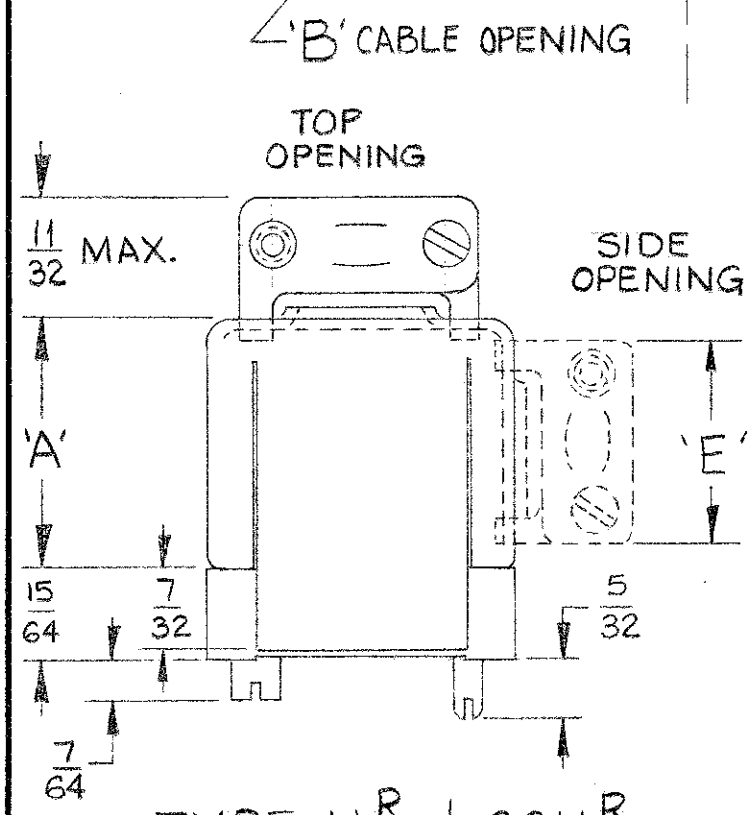
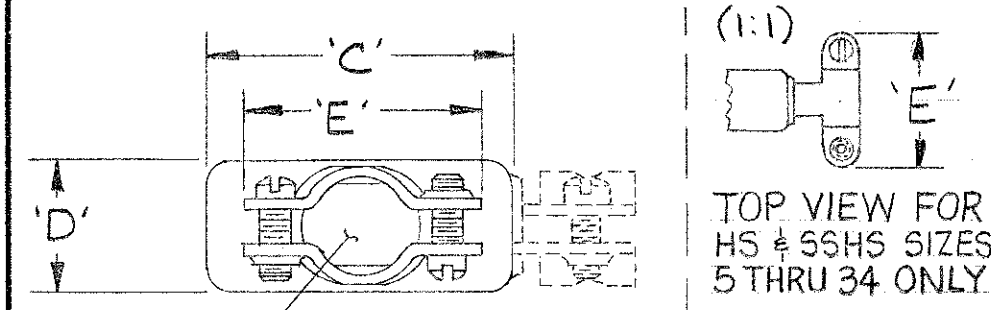

TYPE HS_s & SSH_s
STANDARD GUIDES WITH HOOD & CABLE CLAMP. ST. ST. GUIDES WITH HOOD & CABLE CLAMP. (2:1)

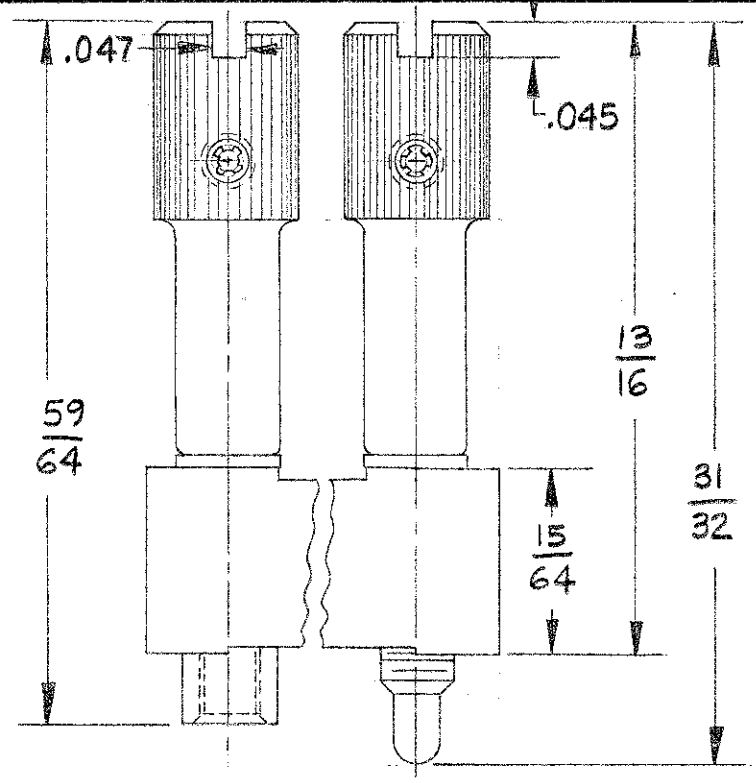

TYPE IK
2-56 TH'D SHORT TURNABLE SCREWLOCKS WITH KNOB (4:1)

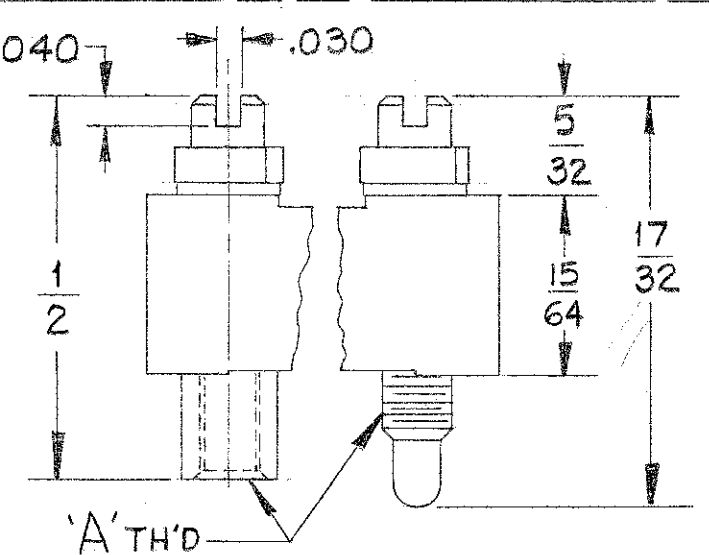

TYPE IKL & 2KL
SHORT TURNABLE SCREWLOCKS KNOBLESS (4:1)

TYPE	'A' THREAD
IKL	2-56
2KL	3-48

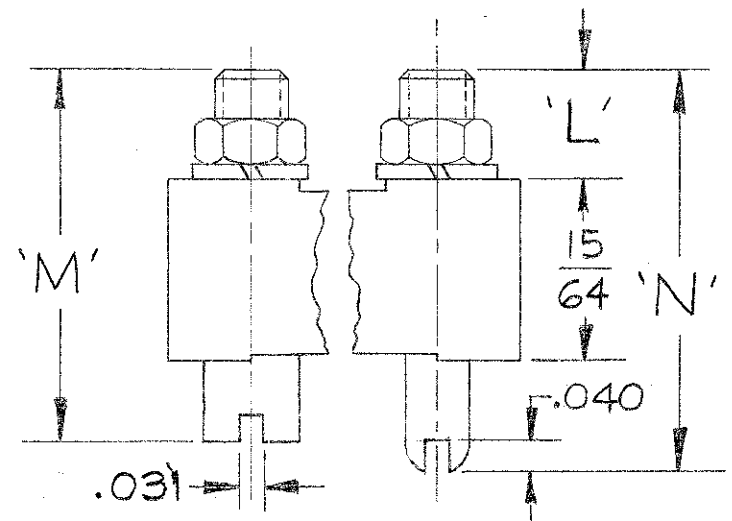

TYPE GUIDES
STANDARD POLARIZED BRASS GUIDES OR OPTIONAL STAINLESS STEEL GUIDES .150 MTG. STUD EXT. OR .250 MTG. STUD EXT. (4:1)

STYLE	'L'	'M'	'N'
ST'D	.150	.484	.531
SS	.150	.484	.531
SS25	.250	.578	.625

STYLE	'L'	'M'	'N'
ST'D	.150	.484	.531
SS	.150	.484	.531
SS25	.250	.578	.625

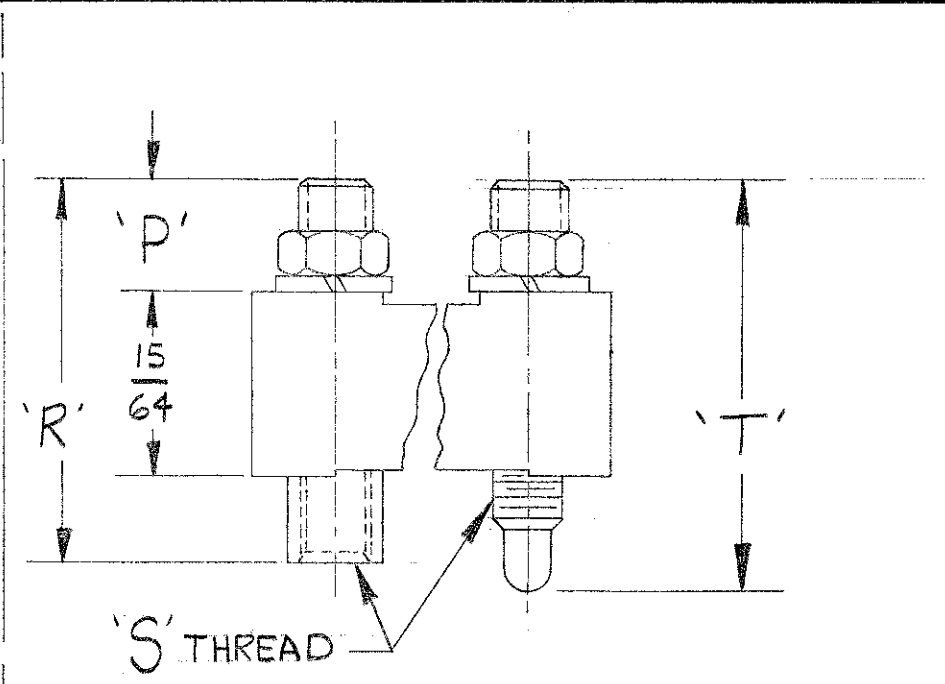

TYPE SCREWLOCKS
FIXED SCREWLOCKS-CHASSIS MTG. (4:1)

STYLE	'P'	'R'	'S' THREAD	'T'
1SL	.150	.500	2-56	.543
2SL	.150	.500	3-48	.543
1SL25	.250	.590	2-56	.630
2SL25	.250	.590	3-48	.630

ON MALE CONNECTORS FEMALE GUIDE OR SCREWLOCK MOUNTED AT 'A' END.
ON FEMALE CONNECTORS MALE GUIDE OR SCREWLOCKS MOUNTED AT 'A' END.

SIZE	'D' REF.	'A'	'B' CABLE OPENING IKHR _s	'B' CABLE OPENING HR _s	'C'	'E' HS & SSH _s	'E' HR & SSH _s	'E' IKHR _s	'F' REF.	'G' ±.010	'H' REF.	'J' MAX.	'K' CABLE OPENING REF.
5	1/4	5/8	.18 x .33	.18 x .24	11/16	19/32	39/64	19/32	—	—	—	—	—
7	1/4	5/8	.18 x .33	.18 x .33	25/32	19/32	39/64	19/32	.130	.562	.72	.50	.13 x .16
9	1/4	5/8	.18 x .33	.18 x .33	7/8	19/32	39/64	19/32	.130	.656	.81	.50	.13 x .16
11	21/64	5/8	.24 x .33	.24 x .33	25/32	19/32	39/64	19/32	.130	.532	.69	.50	.17 x .22
14	21/64	5/8	.24 x .33	.24 x .33	7/8	19/32	39/64	11/16	.130	.625	.78	.50	.17 x .22
20	21/64	5/8	.24 x .46	HR .24 x .46 HS .18 x .31	1 1/16	19/32	53/64	11/16	.130	.814	.97	.87	.26 x .31
26	21/64	5/8	.24 x .46	.24 x .46	1 1/4	11/16	53/64	53/64	.130	1.000	1.16	.87	.39 x .44
29	21/64	5/8	.24 x .46	.24 x .46	1 11/32	11/16	53/64	53/64	.130	1.094	1.25	.87	.39 x .44
34	7/16	5/8	.34 x .46	.34 x .46	1 1/4	11/16	53/64	53/64	.190	1.032	1.19	.87	.42 x .47
44	7/16	1 3/16	.34 x .46	.34 x .46	1 1/2	53/64	53/64	53/64	.190	1.281	1.44	.87	.46 x .53
50	7/16	1 3/16	.34 x .46	.34 x .46	1 5/8	53/64	53/64	53/64	.190	1.408	1.56	.87	.46 x .53

REVISIONS			
SYM.	DESCRIPTION	DATE	APP'D.
E	SEE SHEET 1	11/5/80	[Signature]

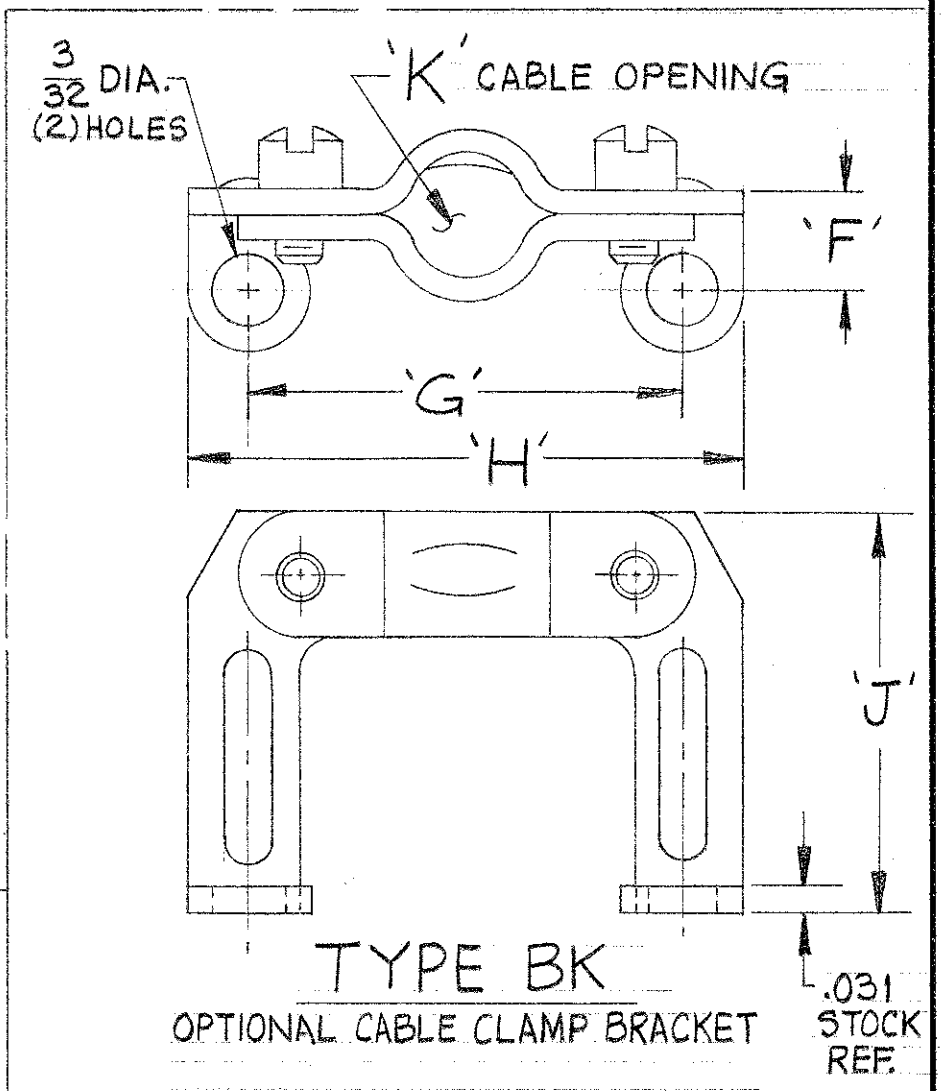

TYPE BK
OPTIONAL CABLE CLAMP BRACKET

EFFECTIVE APRIL 21, 1989 THIS DRAWING BECAME THE PROPERTY OF LITTON SYSTEMS, INCORPORATED WINCHESTER ELECTRONICS DIVISION 400 PARK RD., WATERTOWN, CT 06795

THIS DRAWING, THE DESIGNS, AND IDEAS EMBODIED IN THE DEVICE TO WHICH IT RELATES, AND THE METHODS OF PRODUCING THE DEVICE ARE THE PROPERTY OF U. S. COMPONENTS, INC. AND SHALL NOT BE EMPLOYED, COPIED, OR DISCLOSED TO ANYONE, IN ANY MANNER WITHOUT THE CONSENT OF U. S. COMPONENTS, INC.

NEXT ASS'Y		USED ON		APPLICATION		TOLERANCES UNLESS OTHERWISE SPECIFIED		SCALE AS NOTED		DRAWING NUMBER			
						DECIMALS FRACTIONS ANGULAR		NOTED		093008 ST3 of 4			
U. S. COMPONENTS INC. 35 CARLOUGH ROAD BOHEMIA, N.Y. 11716				TITLE COMPOSITE OUTLINE ASSY, UMI- () 1/2" CONNECTOR				MATERIAL		DRAWN BY ER		DATE 5-23-87	
FINISH				APPROVED BY [Signature]				DATE 4-24-87		REV. E			

4

3

2

1

OPTIONAL KNOB CONFIGURATIONS FOR TURNABLE JACKSCREWS

D

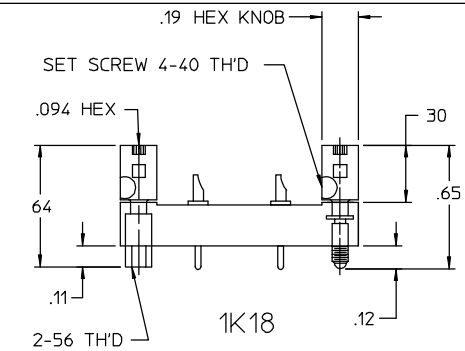
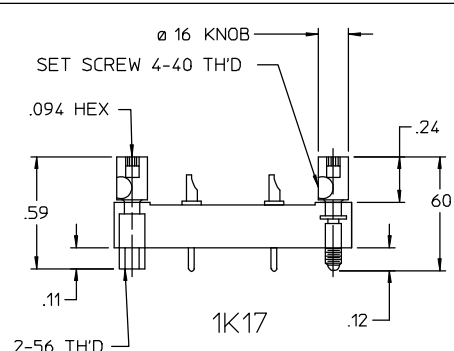
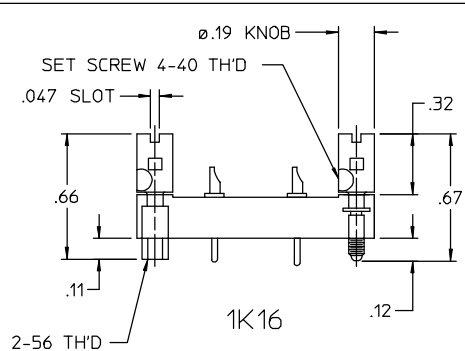
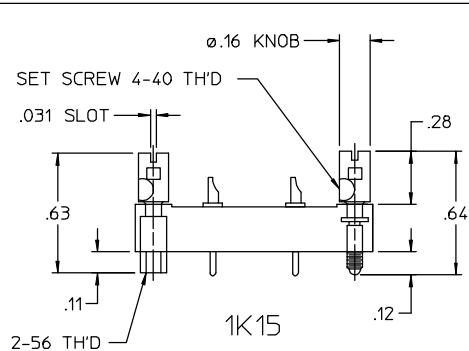

C

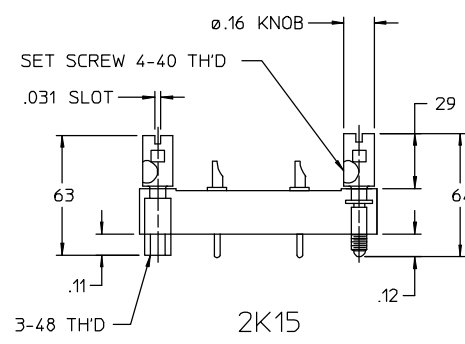
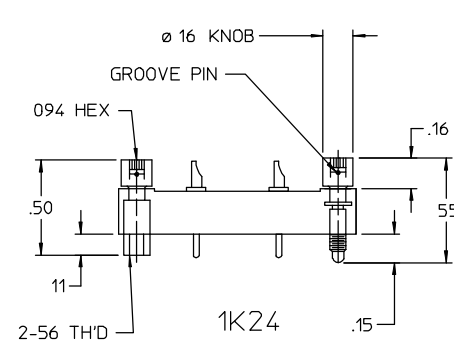
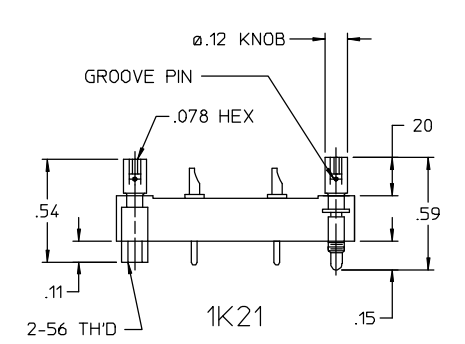
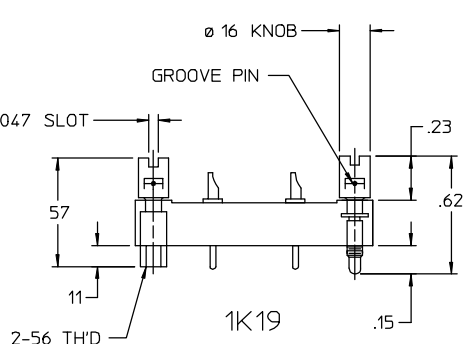

B

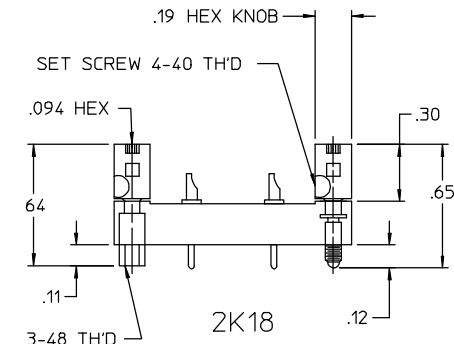
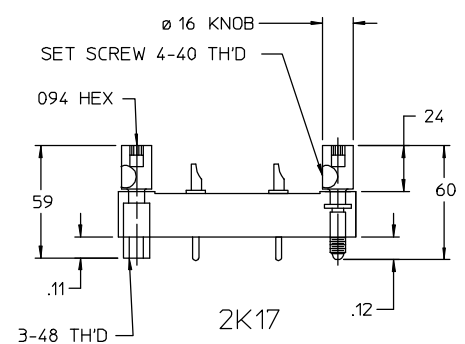
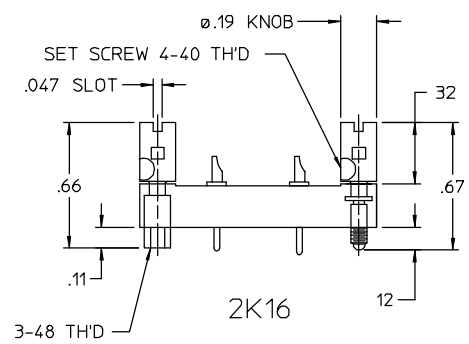

A

REVISIONS	BY: JMG	DATE: 11/05/90
	DESCRIPTION: REVISED & REDRAWN	ECR#: 1550
BY: E	DATE:	DATE:

PER ANSI Y14.5M-1982 UNLESS OTHERWISE SPECIFIED DIMENSIONS ARE IN INCHES.		DISY. CODE
TOLERANCES DECIMALS .XX ± XXX ±		 Winchester Electronics 400 Park Road Watertown, Connecticut 06725
ANGLES ±		
MATERIAL	TITLE	
FINISH	COMPOSITE OUTLINE ASSY. UMI- () M/F CONNECTOR	
DRAWN: J.M.G.	DATE: 11/14/90	CHECKED: DATE:
APPROVED: DATE:	APPROVED: DATE:	REV. E

TITLE	
COMPOSITE OUTLINE ASSY. UMI- () M/F CONNECTOR	
093008	SHT. 4 OF 4

TITLE	
COMPOSITE OUTLINE ASSY. UMI- () M/F CONNECTOR	
093008	SHT. 4 OF 4

4

3

2

1