

DATA SHEET

P18/11

P cores and accessories

Supersedes data of September 2004

2008 Sep 01



FERROXCUBE
A YAGEO COMPANY

CORE SETS

Effective core parameters

SYMBOL	PARAMETER	VALUE	UNIT
$\Sigma(l/A)$	core factor (C1)	0.597	mm ⁻¹
V_e	effective volume	1120	mm ³
l_e	effective length	25.8	mm
A_e	effective area	43.3	mm ²
A_{min}	minimum area	36.0	mm ²
m	mass of set	≈6.0	g

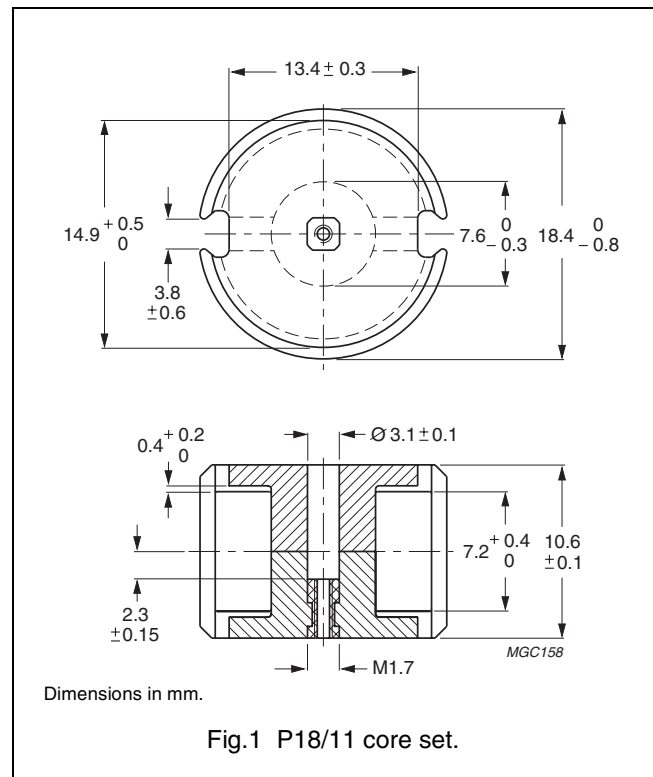

Core sets for filter applications

Clamping force for A_L measurements, 80 ±20 N.

GRADE	A_L (nH)	μ_e	TOTAL AIR GAP (μ m)	TYPE NUMBER (WITH NUT)	TYPE NUMBER (WITHOUT NUT)
3D3 ^{sup}	63 ±3%	≈ 30	≈ 1210	P18/11-3D3-E63/N	P18/11-3D3-E63
	100 ±3%	≈ 47	≈ 670	P18/11-3D3-E100/N	P18/11-3D3-E100
	160 ±3%	≈ 76	≈ 370	P18/11-3D3-E160/N	P18/11-3D3-E160
	1400 ±25%	≈ 665	≈ 0	—	P18/11-3D3
3H3 ^{sup}	160 ±3%	≈ 76	≈ 400	P18/11-3H3-E160/N	P18/11-3H3-E160
	250 ±3%	≈ 119	≈ 240	P18/11-3H3-A250/N	P18/11-3H3-A250
	315 ±3%	≈ 149	≈ 180	P18/11-3H3-A315/N	P18/11-3H3-A315
	400 ±3%	≈ 190	≈ 140	P18/11-3H3-A400/N	P18/11-3H3-A400
	630 ±5%	≈ 299	≈ 80	P18/11-3H3-A630/N	P18/11-3H3-A630
	3100 ±25%	≈ 1470	≈ 0	—	P18/11-3H3

Core sets for general purpose transformers and power applicationsClamping force for A_L measurements, 80 ± 20 N.

GRADE	A_L (nH)	μ_e	AIR GAP (μm)	TYPE NUMBER
3C81	100 $\pm 3\%$	≈ 47	≈ 710	P18/11-3C81-E100
	160 $\pm 3\%$	≈ 76	≈ 400	P18/11-3C81-A160
	250 $\pm 3\%$	≈ 119	≈ 240	P18/11-3C81-A250
	315 $\pm 3\%$	≈ 149	≈ 180	P18/11-3C81-A315
	400 $\pm 3\%$	≈ 190	≈ 140	P18/11-3C81-A400
	4000 $\pm 25\%$	≈ 1900	≈ 0	P18/11-3C81
3C91 <small>des</small>	4000 $\pm 25\%$	≈ 1900	≈ 0	P18/11-3C91
3F3	100 $\pm 3\%$	≈ 47	≈ 710	P18/11-3F3-E100
	160 $\pm 3\%$	≈ 76	≈ 400	P18/11-3F3-A160
	250 $\pm 3\%$	≈ 119	≈ 240	P18/11-3F3-A250
	315 $\pm 3\%$	≈ 149	≈ 180	P18/11-3F3-A315
	400 $\pm 3\%$	≈ 190	≈ 140	P18/11-3F3-A400
	2850 $\pm 25\%$	≈ 1350	≈ 0	P18/11-3F3

Core sets of high permeability gradesClamping force for A_L measurements, 60 ± 20 N.

GRADE	A_L (nH)	μ_e	AIR GAP (μm)	TYPE NUMBER
3E27	7500 $\pm 25\%$	≈ 3560	≈ 0	P18/11-3E27

Properties of core sets under power conditions

GRADE	B (mT) at	CORE LOSS (W) at			
	H = 250 A/m; f = 25 kHz; T = 100 °C	f = 25 kHz; B = 200 mT; T = 100 °C	f = 100 kHz; B = 100 mT; T = 100 °C	f = 100 kHz; B = 200 mT; T = 100 °C	f = 400 kHz; B = 50 mT; T = 100 °C
3C81	≥ 320	≤ 0.26	–	–	–
3C91	≥ 315	–	$\leq 0.07^{(1)}$	$\leq 0.45^{(1)}$	–
3F3	≥ 315	–	≤ 0.13	–	≤ 0.22

Note

1. Measured at 60 °C.

INDUCTANCE ADJUSTERS

General data

ITEM	SPECIFICATION
Material of head and thread	polypropylene (PP), glass fibre reinforced
Maximum operating temperature	125 °C

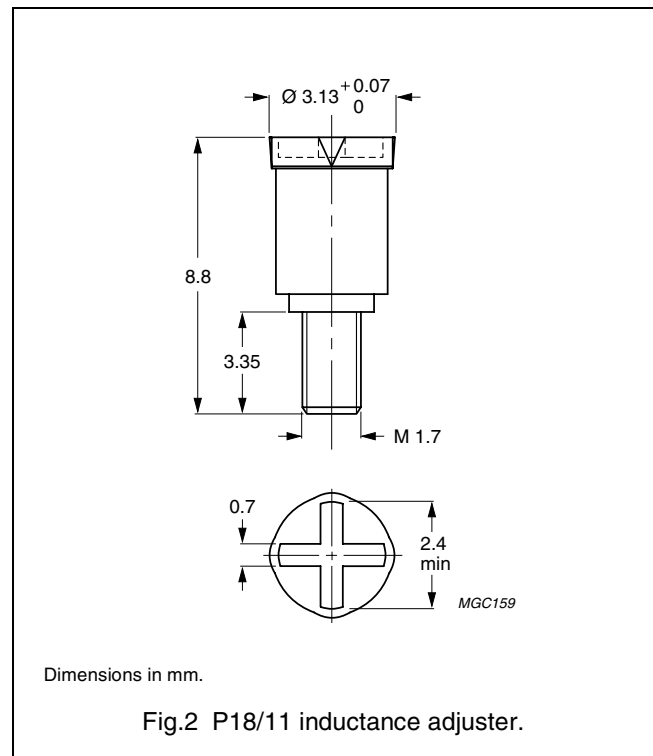

Inductance adjuster selection chart ^{sup} (applies to all types)

GRADE	A _L (nH)	TYPES FOR LOW ADJUSTMENT	ΔL/L ⁽¹⁾	types for medium adjustment	ΔL/L ⁽¹⁾	TYPES FOR HIGH ADJUSTMENT	ΔL/L ⁽¹⁾
3H3	63	–	–	ADJ-P18-YELLOW	16	–	–
	100	–	–	–	–	ADJ-P18-BROWN	42
	160	ADJ-P18-YELLOW	9	ADJ-P18-RED	18	ADJ-P18-BROWN	28
	250	ADJ-P18-RED	11	ADJ-P18-WHITE	14	ADJ-P18-BROWN	18
	315	ADJ-P18-RED	8	ADJ-P18-BROWN	14	ADJ-P18-VIOLET	20
	400	ADJ-P18-WHITE	8	ADJ-P18-VIOLET	16	–	–
	630	ADJ-P18-VIOLET	8	–	–	–	–
	1000	ADJ-P18-VIOLET	5	–	–	–	–
	1250	–	–	–	–	–	–
3D3	40	–	–	–	–	ADJ-P18-YELLOW	19
	63	–	–	ADJ-P18-YELLOW	17	–	–
	100	–	–	–	–	ADJ-P18-RED	26
	160	–	–	ADJ-P18-RED	15	–	–

Note

1. Maximum adjustment range.

COIL FORMERS

General data CP-P18/11

PARAMETER	SPECIFICATION
Coil former material	polybutyleneterephthalate (PBT), glass reinforced, flame retardant in accordance with "UL 94V-0"; UL file number E45329 (R)
Maximum operating temperature	155 °C, "IEC 60085", class F

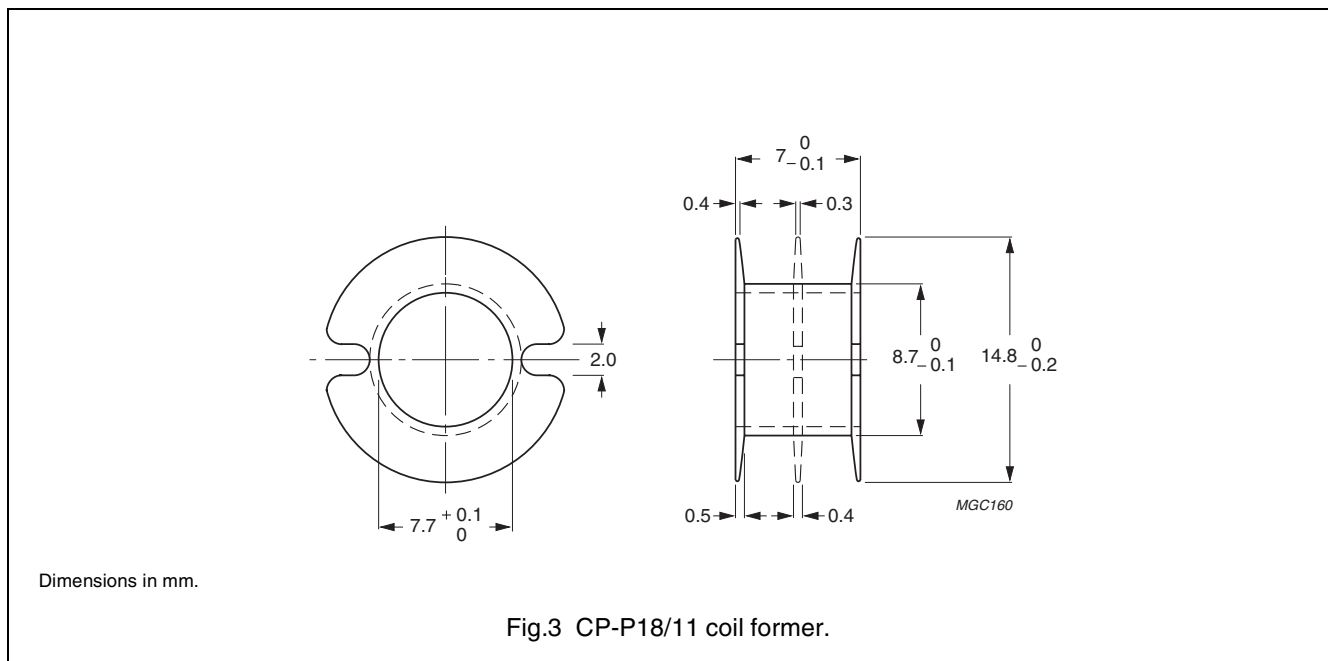

Winding data and area product for CP-P18/11 coil former

NUMBER OF SECTIONS	WINDING AREA (mm ²)	MINIMUM WINDING WIDTH (mm)	AVERAGE LENGTH OF TURN (mm)	AREA PRODUCT Ae x Aw (mm ⁴)	TYPE NUMBER
1	17.1	5.7	36.6	740	CP-P18/11-1S
2	2 x 7.95	2 x 2.65	36.6	2 x 344	CP-P18/11-2S
3	3 x 4.95	3 x 1.6	36.6	3 x 214	CP-P18/11-3S

General data 6-pins P18/11 coil former for PCB mounting

PARAMETER	SPECIFICATION
Coil former material	polyamide (PA6.6), glass reinforced, flame retardant in accordance with "UL 94V-0"; UL file number E41938(M)
Maximum operating temperature	130 °C, "IEC 60085", class B
Pin material	copper-zinc alloy (CuZn), tin (Sn) plated
Resistance to soldering heat	"IEC 60068-2-20", Part 2, Test Tb, method 1B, 350 °C, 3.5 s
Solderability	"IEC 60068-2-20", Part 2, Test Ta, method 1, 235 °C, 2 s

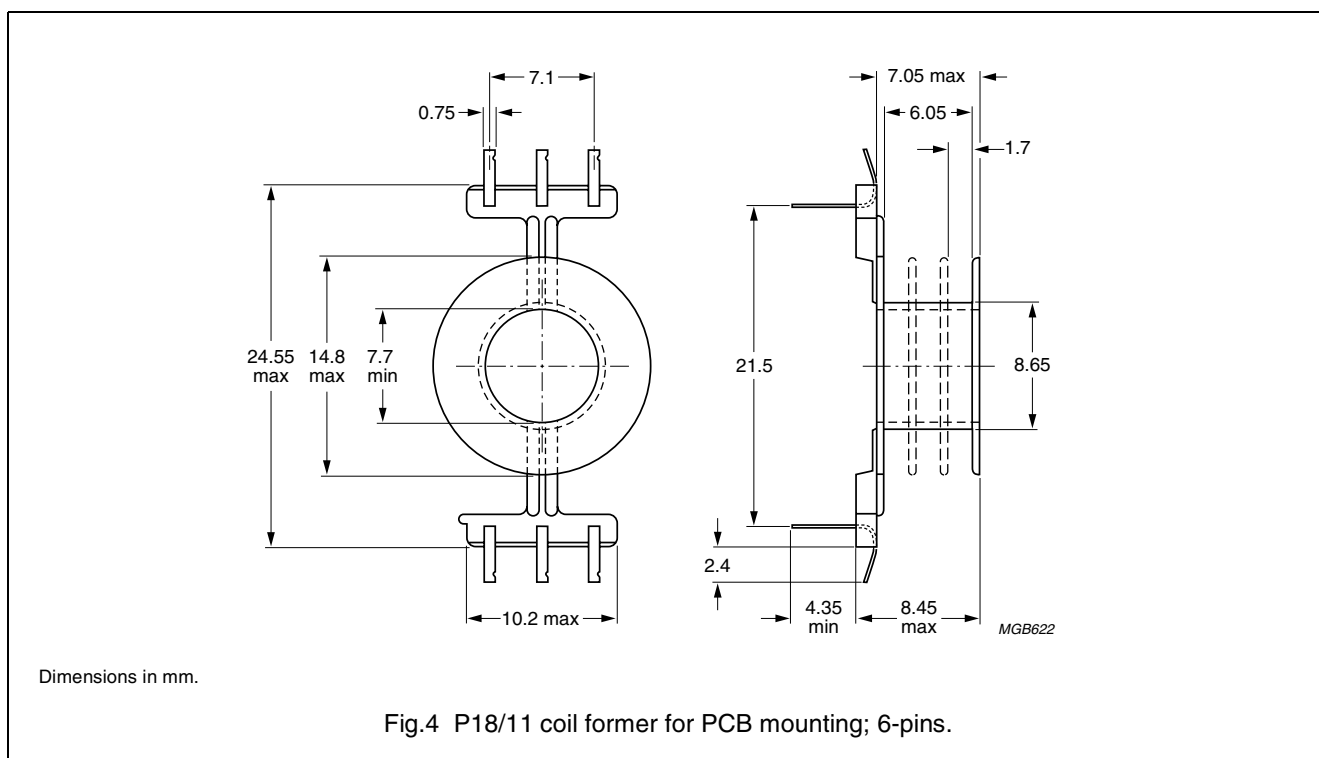

Winding data and area product for 6-pins P18/11 coil former for PCB mounting

NUMBER OF SECTIONS	MINIMUM WINDING AREA (mm ²)	NOMINAL WINDING WIDTH (mm)	AVERAGE LENGTH OF TURN (mm)	LENGTH OF PINS (mm)	AREA PRODUCT Ae x Aw (mm ⁴)	TYPE NUMBER
1	16.8	6.0	36.7	4.4	727	CPV-P18/11-1S-6PD
1	16.8	6.0	36.7	6.8	727	CPV-P18/11-1S-6PDL
2	2 x 7.61	2 x 2.8	36.7	4.4	2 x 330	CPV-P18/11-2S-6PD
2	2 x 7.61	2 x 2.8	36.7	6.8	2 x 330	CPV-P18/11-2S-6PDL
3	3 x 4.58	3 x 1.7	36.7	4.4	3 x 198	CPV-P18/11-3S-6PD
3	3 x 4.58	3 x 1.7	36.7	6.8	3 x 198	CPV-P18/11-3S-6PDL

MOUNTING PARTS

General data for mounting parts

ITEM	REMARKS	FIGURE	TYPE NUMBER
Tag plate	material: phenolformaldehyde (PF), glass reinforced	5	TGP-P18/11-C
	flame retardant: in accordance with "UL 94V-0"; UL file number E41429		
	maximum operating temperature: 180 °C, "IEC 60085", class H		
	pins: copper-tin alloy (CuSn), tin (Sn) plated		
	resistance to soldering heat in accordance with "IEC 60068-2-20", Part 2, Test Tb, method 1B: 350 °C, 3.5 s		
	solderability in accordance with "IEC 60068-2-20", Part 2, Test Ta, method 1: 235 °C, 2 s		
Container	copper-zinc alloy (CuZn), tin (Sn) plated	6	CON-P18/11
	earth pins: presoldered		
Spring	CrNi-steel	7	SPR-P18/11
	spring force: ≈100 N when mounted		
Clamp	spring steel, tin-plated	8	CLM/TP-P18/11
Washer	phenolformaldehyde (PF)	9	WAS-CLM/TP-P18/11

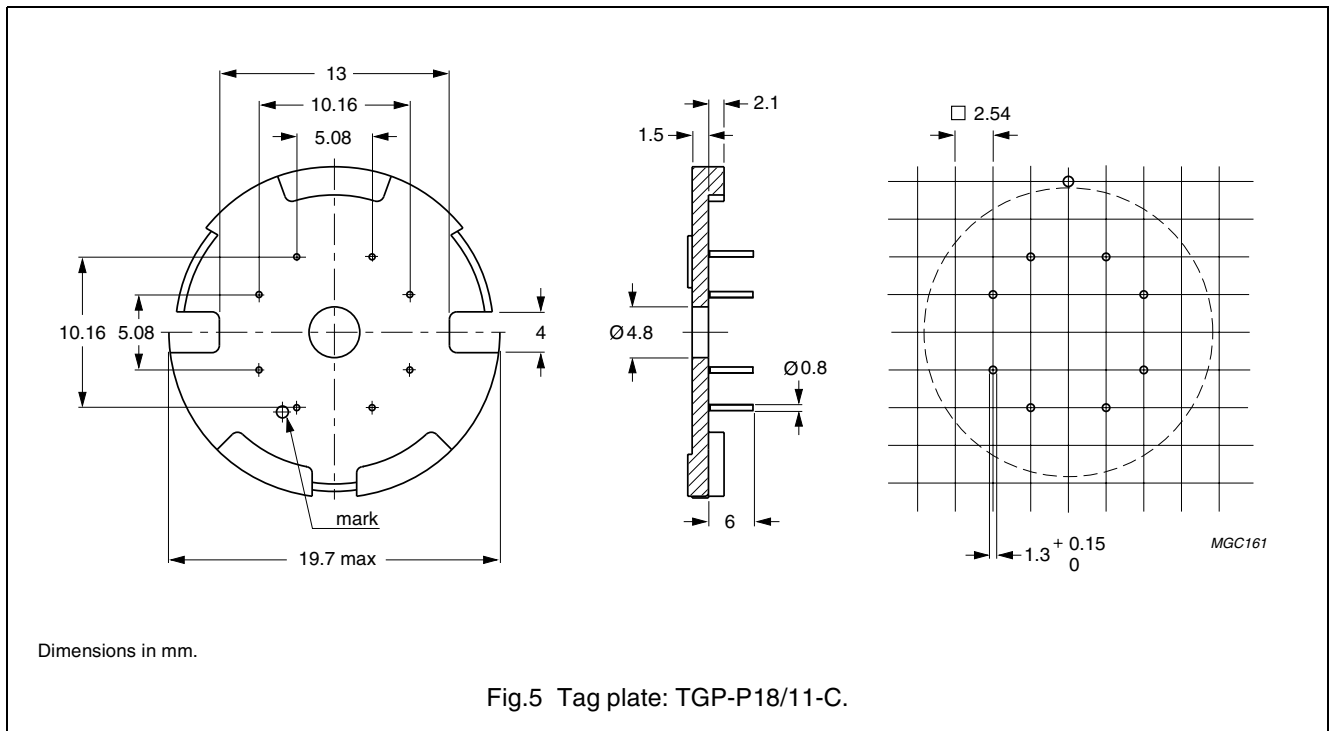

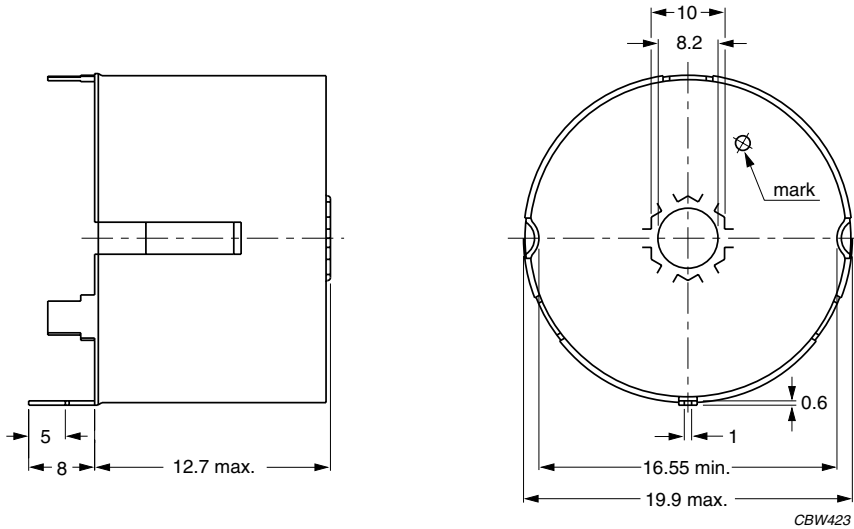

Dimensions in mm.

Fig.6 Container: CON-P18/11.

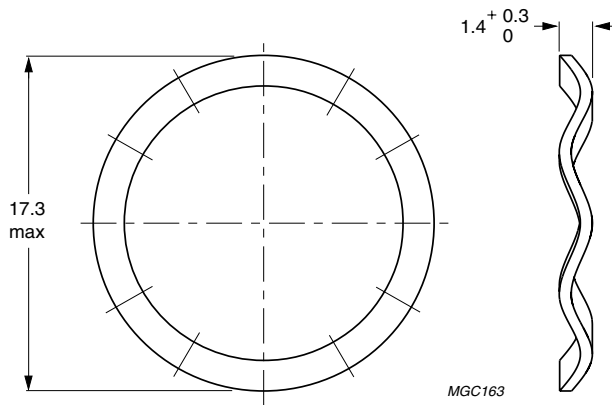

Dimensions in mm.

Fig.7 Spring: SPR-P18/11.

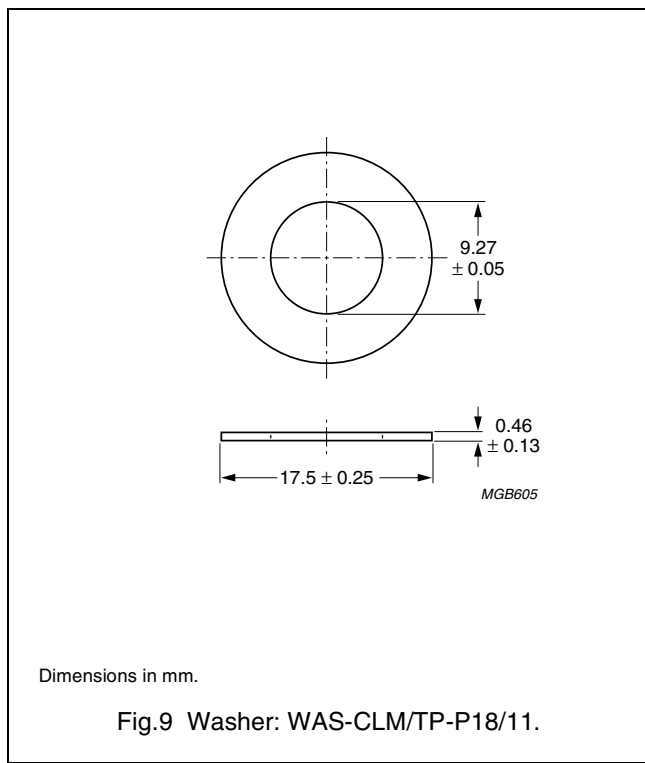
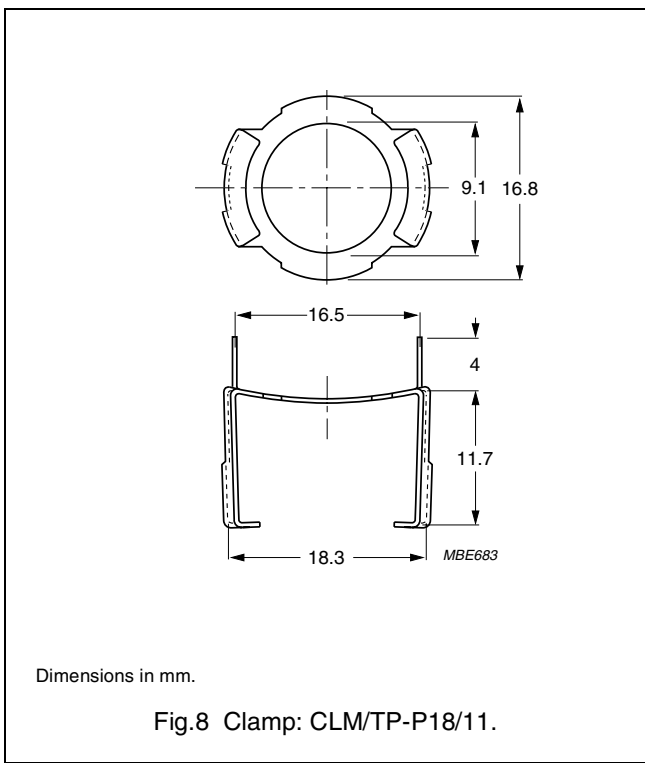



DATA SHEET STATUS DEFINITIONS

DATA SHEET STATUS	PRODUCT STATUS	DEFINITIONS
Preliminary specification	Development	This data sheet contains preliminary data. Ferroxcube reserves the right to make changes at any time without notice in order to improve design and supply the best possible product.
Product specification	Production	This data sheet contains final specifications. Ferroxcube reserves the right to make changes at any time without notice in order to improve design and supply the best possible product.

DISCLAIMER

Life support applications — These products are not designed for use in life support appliances, devices, or systems where malfunction of these products can reasonably be expected to result in personal injury. Ferroxcube customers using or selling these products for use in such applications do so at their own risk and agree to fully indemnify Ferroxcube for any damages resulting from such application.

PRODUCT STATUS DEFINITIONS

STATUS	INDICATION	DEFINITION
Prototype		These are products that have been made as development samples for the purposes of technical evaluation only. The data for these types is provisional and is subject to change.
Design-in		These products are recommended for new designs.
Preferred		These products are recommended for use in current designs and are available via our sales channels.
Support		These products are not recommended for new designs and may not be available through all of our sales channels. Customers are advised to check for availability.