

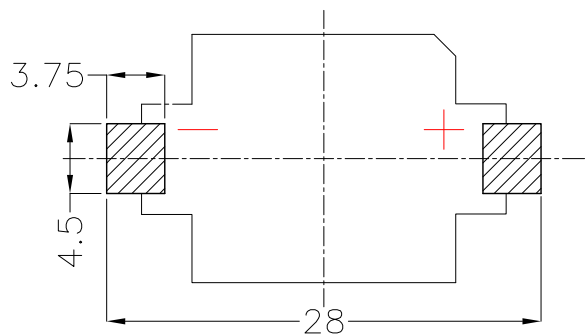

REV.	ECN NO.	REVISED	DATE

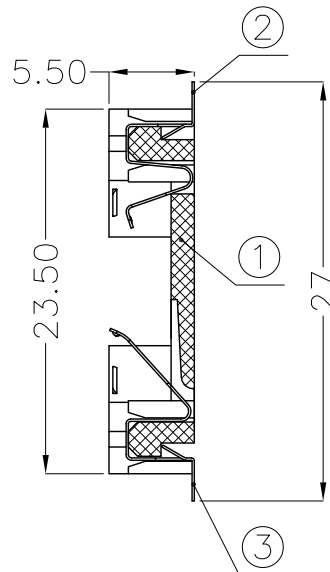
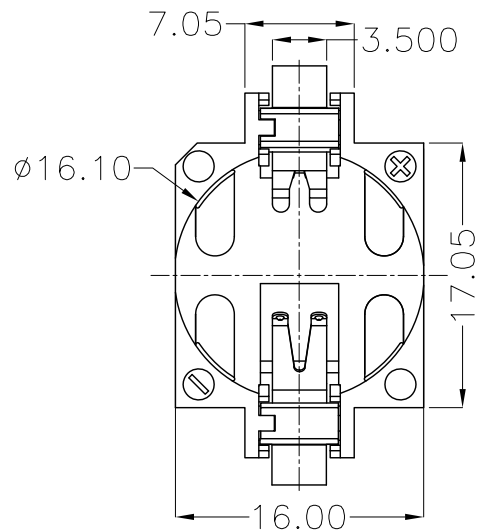

PCB Layout Diagram  
Top View

NOTE:  
 1.MATERIAL:  
 a.HOUSING:LCP UL94V-0  
 b.CONTACT:PHOSPHOR BRONZE  
 (SURFACE PLATING: Au 1U")  
 SEE ORDERING INFORMATION  
 2.ELECTRIC:  
 a.CONTACT RESISTANCE: 30 MILLIOHMS MAX  
 b.INSULATION RESISTANCE: 1000 MEGA OHMS MIN  
 c.DIELECTNIC VOLTAGE: 500V AC ONE SEC LEVEL  
 d.OPERATING TEMPERATURE: -25°C~ +85°C

ORDERING INFORMATION

BS-16-B\*\*\*006

电池座系列  
 BS-16系列  
 SMT 180° TYPE

PLATING:  
 A-Au1U"  
 J-Ni100U"~120U"  
 K-Sn100U"~120U"

MATERIAL:  
 1A-PBT BLACK  
 1B-PA66 BLACK  
 2A-PPA BROWN  
 2B-PPA BLACK  
 3A-PPS BROWN  
 3B-PPS BLACK  
 4A-LCP WHITE  
 4B-LCP BLACK

工程部  
 2020-05-11  
 LQ HUANG

3	TERMINAL(-)	1	PHOSPHOR BRONZE, T=0.15mm	Au-Plating
2	TERMINAL(+)	1	PHOSPHOR BRONZE, T=0.15mm	Au-Plating
1	HOUSING	1	LCP	WHITE
NO.	PART NAME	Q'TY	MATERIAL	PLATING & COLOR

UNLESS OTHERWISE SPECIFIED TOLERANCES		<a href="http://www.meiyangdz.com">www.meiyangdz.com</a>			
DECIMALS: X :±0.30 X.X :±0.25 X.XX :±0.20 X.XXX :±0.10	ANGLES: X :±1° X.X :±0.5°	DSND	YangFeng	DATE	2020-05-11
WEIGHT: 1.34g		CHKD	ZhouRuicai	DATE	2020-05-11
SHEET 1 OF 1		APVD	XueShunyong	DATE	2020-05-11
SCALE: 2:1		SIZE: A4	VIEW:	TITLE: BS-1632-1 Au SMT	
UNIT: mm		REV.: A/0	OBJECT: MY	PART NO.: BS-16-B4AA006	
				DRAW NO.:MY-CP-0224	