

HG-S SERIES

Related Information	■ General terms and conditions..... F-3	■ Selection guide P.1021~
	■ Glossary of terms..... P.1587	■ General precautions P.1595

- FIBER SENSORS
- LASER SENSORS
- PHOTOELECTRIC SENSORS
- MICRO PHOTOELECTRIC SENSORS
- AREA SENSORS
- SAFETY LIGHT CURTAINS / SAFETY COMPONENTS
- PRESSURE / FLOW SENSORS
- INDUCTIVE PROXIMITY SENSORS
- PARTICULAR USE SENSORS
- SENSOR OPTIONS
- SIMPLE WIRE-SAVING UNITS
- WIRE-SAVING SYSTEMS
- MEASUREMENT SENSORS
- STATIC CONTROL DEVICES
- LASER MARKERS
- PLC
- HUMAN MACHINE INTERFACES
- ENERGY MANAGEMENT SOLUTIONS
- FA COMPONENTS
- MACHINE VISION SYSTEMS
- UV CURING SYSTEMS



Featuring optical absolute method in the slim and strong unit body

SENSOR HEAD

Robust and slim body contributes to a longer service life

The slim unit body contains plain bearings with 2-point support structure disperses load and achieves superb durability. The sensor head offers long life and reduces maintenance costs dramatically.

Robust and slim body

Slim body like a pencil type sensor head

Hot-swappable

Bending-resistant cable

A bending-resistant cable provides peace of mind even when the sensor is installed on a movable tool.

Plain bearings with 2-point support structure

A new structure supports the spindle with upper and lower plain bearings to significantly increase rigidity to lateral loads.

Durability to withstand more than 200 million vertical sliding operations (typical value) (Note 1)

Notes: 1) Value on HG-S1010 / HG-S1110.
 2) Value on HG-S1010(R) / HG-S1110(R).
 3) Value calculated from the clearance of the upper and lower plain bearings.

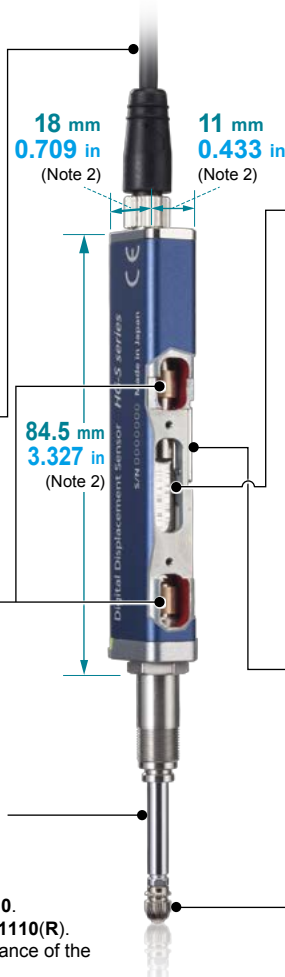

Optical absolute method

No "value skipping" or "unset zero point"

Displacement is measured by reading a glass scale with a different slit pattern at each reading position using a high-resolution sensor. This eliminates "value skipping" even when measuring at high speed, and there is no concern of "unset zero point".

Class-top accuracy

High-precision sensor head [HG-S1110(R)]

Resolution 0.1 μm 0.004 mil	Indication accuracy Full range: 1.0 μm 0.039 mil or less Narrow range: 0.5 μm 0.020 mil or less
---------------------------------------	--

Resolution
No.1* in class

Indication accuracy
No.1* in class

* As of June 2017, in-company survey.

Metal guide whirl-stop structure



Tip deviation amount of 35 μm 1.378 mil or less (typical value) (Note 3) [40 μm 1.575 mil or less (typical value) on the HG-S1032 (Note 3)]

- Selection Guide
- Laser Displacement
- Magnetic Displacement
- Contact Displacement
- Collimated Beam Sensors
- Metal-sheet Double-feed Detection
- Digital Panel Controller
- Other Products

HG-S

Superb craftsmanship!

The accuracy and robustness of the **HG-S** series are backed by master craftsmanship. The plain bearings are accurately aligned with the center of the spindle during their installation to the top and bottom sections of the body to ensure smooth sliding. This process involves careful adjustment of each bearing by a skilled worker. Even though the plain bearing has a certain width, the clearance is managed to the accuracy of several μm . Those with experience in mechanisms design will know that this value signifies amazingly high control precision. The high-precision, robust sensor is made possible by master craftsmanship. Maximize the high accuracy of our sensors in your pursuit of "ever higher levels of quality."

Resistance to lateral load

Lateral loads often occur in the workplace, so we conduct our own unique lateral load resistance testing. There is a reason why you can use this product with peace of mind for a long time.

Withstands more than 100 million sliding operations under application of lateral load (typical value) (Note 1)

Lateral load resistance
No.1* in class

* As of June 2017, in-company survey.

Example of a lateral load occurring in the workplace

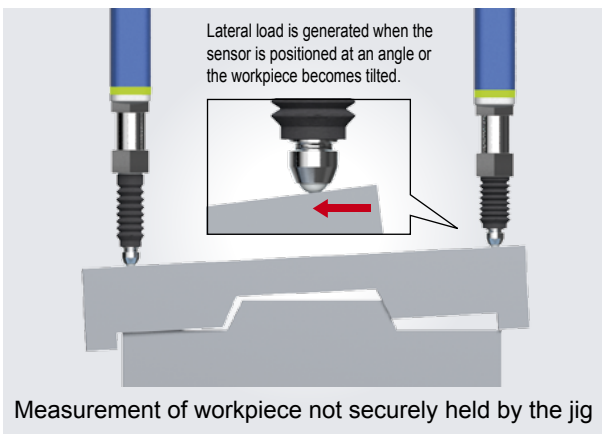

Lateral load resistance test (Note 2)

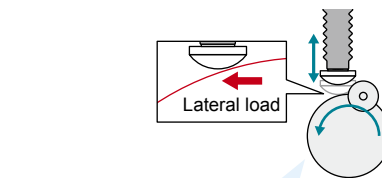

Hitting the spindle laterally with a roller
We conducted our own unique lateral load resistance testing
<Test conditions>
Impact cycle: 13 times per second
Impact stroke: 1 mm 0.039 in

Notes:
1) Value on **HG-S1010** / **HG-S1110**.
2) Button-type probe for evaluation purposes was installed on the test sample for the lateral load resistance test.

Resistance to shock and vibration

Shock resistance: 200 G approx.

1,960 m/s^2 acceleration in X, Y and Z directions three times each

Vibration resistance: 20 G approx.

10 to 500 Hz frequency
(**HG-S1032**: 10 to 150 Hz frequency),
3 mm 0.118 in double amplitude
(Maximum acceleration 196 m/s^2)
in X, Y and Z directions for two hours each

Vibration / shock resistance
No.1* in class

* As of June 2017, in-company survey.

Resistant to upward thrust impact

Spindle stopper installed at the lower section

Even if unexpected upward thrust occurs, the lower part of the spindle blocks the impact. Damage to the internal structure, including the glass scale, is minimized.

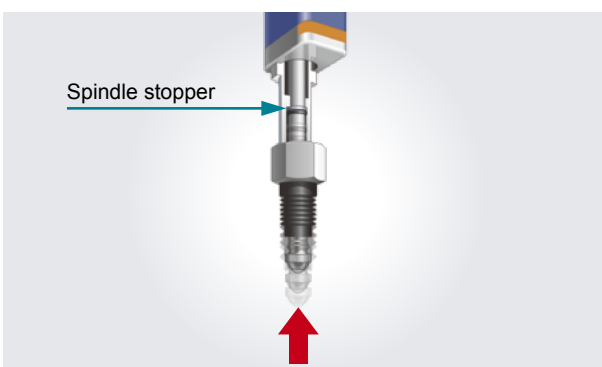

Hot-swappable

Change of sensor head without turning off the power supply

The sensor head can be changed safely without turning off the controller. This reduces the man-hours required for the change of line setup for processing of different workpieces, thus achieving a significant reduction of setup change time.

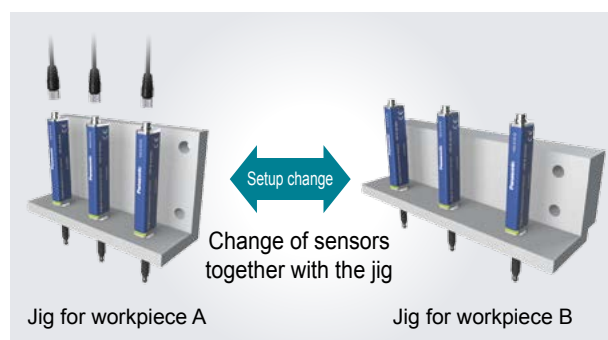

FIBER SENSORS

LASER SENSORS

PHOTOELECTRIC SENSORS

MICRO PHOTOELECTRIC SENSORS

AREA SENSORS

SAFETY LIGHT CURTAINS / SAFETY COMPONENTS

PRESSURE / FLOW SENSORS

INDUCTIVE PROXIMITY SENSORS

PARTICULAR USE SENSORS

SENSOR OPTIONS

SIMPLE WIRE-SAVING UNITS

WIRE-SAVING SYSTEMS

MEASUREMENT SENSORS

STATIC CONTROL DEVICES

LASER MARKERS

PLC

HUMAN MACHINE INTERFACES

ENERGY MANAGEMENT SOLUTIONS

FA COMPONENTS

MACHINE VISION SYSTEMS

UV CURING SYSTEMS

Selection Guide

Laser Displacement

Magnetic Displacement

Contact Displacement

Collimated Beam Sensors

Metal-sheet Double-feed Detection

Digital Panel Controller

Other Products

HG-S

- FIBER SENSORS
- LASER SENSORS
- PHOTOELECTRIC SENSORS
- MICRO PHOTOELECTRIC SENSORS
- AREA SENSORS
- SAFETY LIGHT CURTAINS / SAFETY COMPONENTS
- PRESSURE / FLOW SENSORS
- INDUCTIVE PROXIMITY SENSORS
- PARTICULAR USE SENSORS
- SENSOR OPTIONS
- SIMPLE WIRE-SAVING UNITS
- WIRE-SAVING SYSTEMS
- MEASUREMENT SENSORS
- STATIC CONTROL DEVICES
- LASER MARKERS
- PLC
- HUMAN MACHINE INTERFACES
- ENERGY MANAGEMENT SOLUTIONS
- FA COMPONENTS
- MACHINE VISION SYSTEMS
- UV CURING SYSTEMS
- Selection Guide
- Laser Displacement
- Magnetic Displacement
- Contact Displacement
- Collimated Beam Sensors
- Metal-sheet Double-feed Detection
- Digital Panel Controller
- Other Products

CONTROLLER

Versatile and easy-to-use controller

The controller features the industry's first* dual display and offers versatile functions and excellent ease of use. It allows simple and reliable operation of the advanced measurement function in a diversity of applications.

* As a sensor product using optical absolute method, as of September 2015 (according to in-company survey)

Dual display for added indication flexibility (equipped with NAVI function)

The 2-line digital display simultaneously shows head measurement (measured value) and judgment value (calculated value).

Industry's first!*

High-speed response of 3 ms in combination with any sensor head

All-direction LCD

The high-contrast LCD provides sharp and clear indications and wide viewing angle.

Equipped with intuitive circle meter

Values between allowable maximum and minimum values are indicated in green. Values outside of the allowable range are indicated in orange. This provides at-a-glance understanding of the margin to the tolerance limits.



Higher than maximum value



Lower than minimum value

Anytime selection of function to copy

The selective copy function significantly reduces the man-hours required for initial setting and maintenance.



Provided with maintenance mode useful on production floor

The following data are stored and can be used for analysis on the spot.

- Abnormal sensor head upward thrust value
- Number of sensor head upward thrusts
- Cumulative total number of sliding operations

Alarm setting for notification of upward thrust

Alarm can be set to notify an upward thrust (stroke) that exceeds the set level. This allows you to conduct a preventive maintenance before the sensor head generates a malfunction.

Easy-to-understand 2-line digital display

The 2-line digital display simultaneously shows sensor head measurement and judgment value.



Sub-screen: Displays sensor head measurement and other data.

Main screen: Displays judgment value.

Easy tolerance setting

Simple 1-point teaching

Align with master workpiece and press ENTER key for easy tolerance setting.



One push!

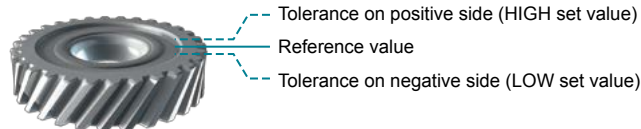

Tolerance setting completed!

No need for trigger input

Equipped with self-trigger hold function

Easy setting of time length from measurement start to measurement stabilization.
Minimizes measurement fluctuation due to the vibration caused by stopping of spindle rotation.

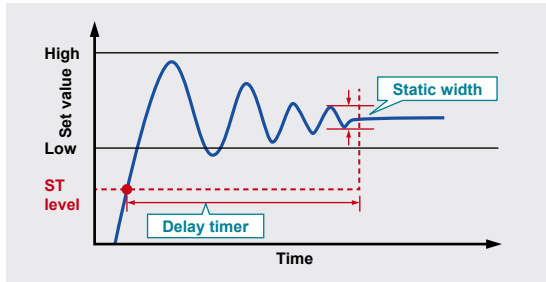

(1) Static width setting

Stability range above the ST level can be set as desired.
Set the range where measurements are considered to be stable.

(2) Delay timer setting

Desired delay time after measurement exceeding the ST level can be set.
Set the time required for stabilization of measurement.

Lateral connection of slave units for added operational ease

Connection of up to 15 slaves units

One master unit can be connected with up to 15 slave units in any order. This allows easy multi-point calculations.

(Example: Connection of 15 slave units)

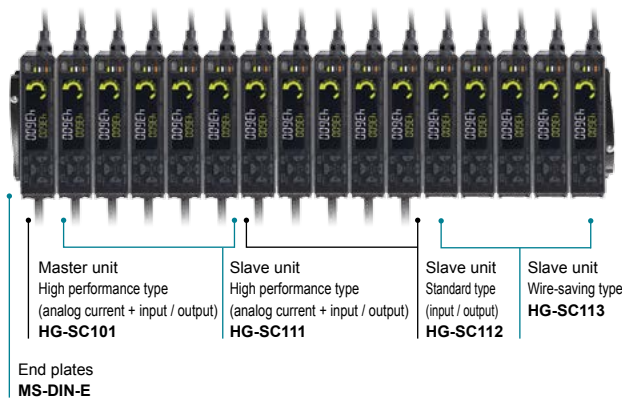

End plates
MS-DIN-E

* End plates (optional) must be mounted on both sides of the controller after the connection of slave units.

Controller variations

- **Master unit (1 model)**
 - High performance type (analog current + input / output)
- **Slave unit (3 models)**
 - High performance type (analog current + input / output)
 - Standard type (input / output)
 - Wire-saving type

Hold function (9 types)

Sample hold (S-H)	Peak hold (P-H)	Bottom hold (B-H)
Peak-to-peak hold (P-P)	Peak-to-peak hold/2 (P-P/2)	
NG hold (NG-H)	Self-sample hold (SLF.S-H)	
Self-peak hold (SLF.P-H)	Self-bottom hold (SLF.B-H)	

Calculation function (8 types)

MAX (maximum value)	MIN (minimum value)	FLAT (flatness)	AVERAG (average value)
STAND (reference difference)	TORSIN (torsion)	CURVEA (curvature)	THICK (thickness)

FIBER SENSORS

LASER SENSORS

PHOTOELECTRIC SENSORS

MICRO PHOTOELECTRIC SENSORS

AREA SENSORS

SAFETY LIGHT CURTAINS / SAFETY COMPONENTS

PRESSURE / FLOW SENSORS

INDUCTIVE PROXIMITY SENSORS

PARTICULAR USE SENSORS

SENSOR OPTIONS

SIMPLE WIRE-SAVING UNITS

WIRE-SAVING SYSTEMS

MEASUREMENT SENSORS

STATIC CONTROL DEVICES

LASER MARKERS

PLC

HUMAN MACHINE INTERFACES

ENERGY MANAGEMENT SOLUTIONS

FA COMPONENTS

MACHINE VISION SYSTEMS

UV CURING SYSTEMS

Selection Guide

Laser Displacement

Magnetic Displacement

Contact Displacement

Collimated Beam Sensors

Metal-sheet Double-feed Detection

Digital Panel Controller

Other Products

HG-S

- FIBER SENSORS
- LASER SENSORS
- PHOTO-ELECTRIC SENSORS
- MICRO PHOTO-ELECTRIC SENSORS
- AREA SENSORS
- SAFETY LIGHT CURTAINS / SAFETY COMPONENTS
- PRESSURE / FLOW SENSORS
- INDUCTIVE PROXIMITY SENSORS
- PARTICULAR USE SENSORS
- SENSOR OPTIONS
- SIMPLE WIRE-SAVING UNITS
- WIRE-SAVING SYSTEMS
- MEASUREMENT SENSORS
- STATIC CONTROL DEVICES
- LASER MARKERS
- PLC
- HUMAN MACHINE INTERFACES
- ENERGY MANAGEMENT SOLUTIONS
- FA COMPONENTS
- MACHINE VISION SYSTEMS
- UV CURING SYSTEMS
- Selection Guide
- Laser Displacement
- Magnetic Displacement
- Contact Displacement
- Collimated Beam Sensors
- Metal-sheet Double-feed Detection
- Digital Panel Controller
- Other Products

COMMUNICATION UNIT FOR DIGITAL DISPLACEMENT SENSOR

Directly send the measurement values of multiple sensors to a host!

Communication unit for CC-Link IE Field / CC-Link

NEW

Communication unit for CC-Link IE Field
SC-HG1-CEF



iQSS support is planned

NEW

Communication Unit for CC-Link
SC-HG1-C



Supports iQSS

CC-Link IE Field

Communication speed: 1 Gbps

CC-Link

Communication speed: 10 Mbps (max.)

The communication unit can be used to connect directly to a CC-Link network. This lets you acquire digital data and ON / OFF information in real-time without a program. In addition, you can change controller settings and log measurement data via the CC-Link network, so you can also use the system for preventative maintenance of digital displacement sensors.

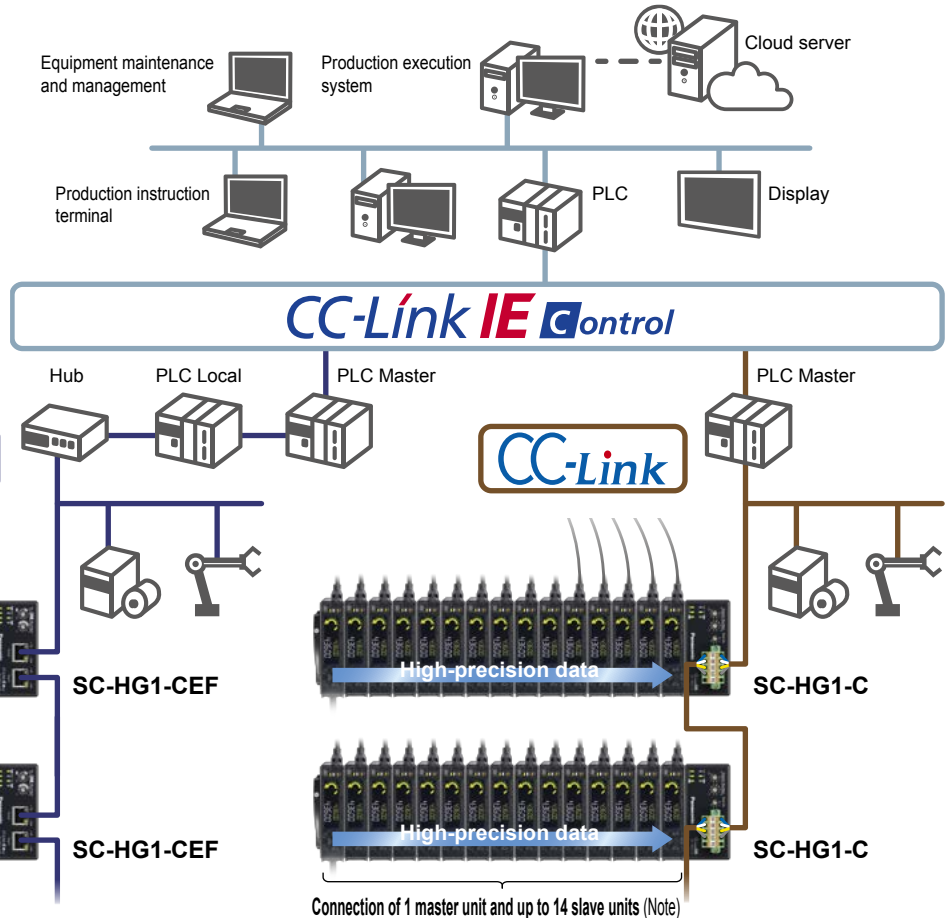

CC-Link IE Field

CC-Link

Connection of 1 master unit and up to 14 slave units (Note)

Connection of 1 master unit and up to 14 slave units (Note)

Note: When connected to a communication unit for digital displacement sensor, up to 14 slave units can be connected per master unit

Communication unit for RS-485

Communication unit for RS-485
SC-HG1-485



Communication speed: 1.2 kbps / 2.4 kbps / 4.8 kbps / 9.6 kbps / 19.2 kbps / 38.4 kbps / 57.6 kbps / 115.2 kbps

For use of high-precision measurement results as traceability data examples. Transfers not only measurements results obtained at multiple points but also setting statuses as digital data in a batch. Provides powerful support to the management of inspection records and identification of failure causes.

Note: When connected to a communication unit for digital displacement sensor, up to 14 slave units can be connected per master unit.

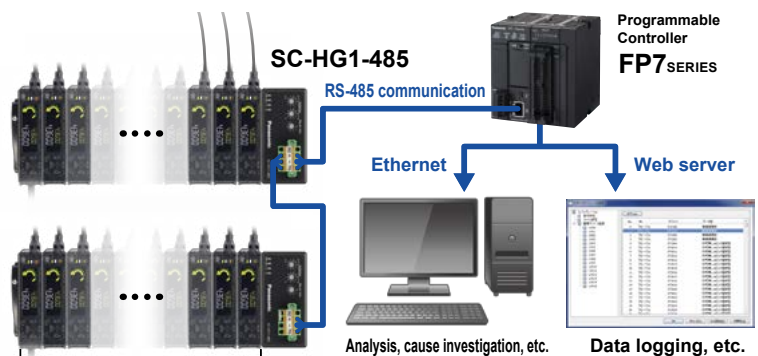

Connection of 1 master unit and up to 14 slave units (Note)

RS-485 communication protocol
MODBUS (RTU / ASCII): Connection of up to 99 stations
MEWTocol-COM: Connection of up to 64 stations

APPLICATIONS

AUTOMOTIVE APPLICATIONS

OTHER APPLICATIONS

Coupling assembly inspection



Installed height measurement



Motor shaft eccentricity measurement



Crankshaft dimension measurement

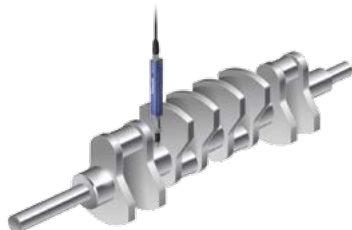

Screw head height measurement

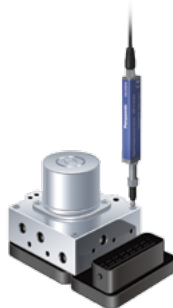

X-Y stage position measurement

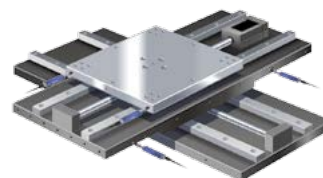

Transmission parts height measurement



Automotive parts dimension measurement



Tablet surface flatness measurement

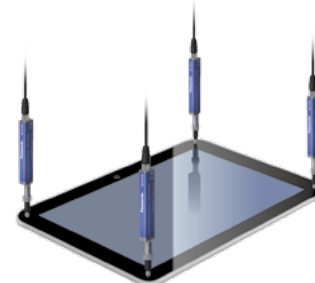

Management of press-fit points of press-fit parts

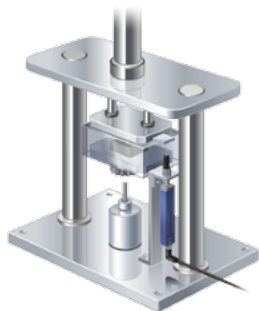

Contact-type displacement sensor and load cell are used to manage pressure change point and stroke position for the confirmation of proper press-fit mounting.

Resin roller eccentricity measurement



FIBER SENSORS

LASER SENSORS

PHOTO-ELECTRIC SENSORS

MICRO PHOTO-ELECTRIC SENSORS

AREA SENSORS

SAFETY LIGHT CURTAINS / SAFETY COMPONENTS

PRESSURE / FLOW SENSORS

INDUCTIVE PROXIMITY SENSORS

PARTICULAR USE SENSORS

SENSOR OPTIONS

SIMPLE WIRE-SAVING UNITS

WIRE-SAVING SYSTEMS

MEASUREMENT SENSORS

STATIC CONTROL DEVICES

LASER MARKERS

PLC

HUMAN MACHINE INTERFACES

ENERGY MANAGEMENT SOLUTIONS

FA COMPONENTS

MACHINE VISION SYSTEMS

UV CURING SYSTEMS

Selection Guide

Laser Displacement

Magnetic Displacement

Contact Displacement

Collimated Beam Sensors

Metal-sheet Double-feed Detection



Digital Panel Controller

Other Products

HG-S

ORDER GUIDE

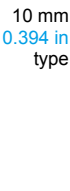

Sensor heads

Type			Appearance	Measurement range	Resolution	Model No.
10 mm 0.394 in type	General purpose	Standard	General purpose  32 mm 1.260 in type	10 mm 0.394 in	0.5 μm 0.020 mil	HG-S1010
		Low measuring force				HG-S1010R
	High precision	Standard	High precision  10 mm 0.394 in type		0.1 μm 0.004 mil	HG-S1110
		Low measuring force				HG-S1110R
32 mm 1.260 in type	General purpose	Standard	 10 mm 0.394 in type	32 mm 1.260 in	0.5 μm 0.020 mil	HG-S1032

Sensor head connection cables (bending-resistant type)

Type	Appearance	Cable length	Model No.
Straight connector		3 m 9.843 ft	CN-HS-C3
		7 m 22.966 ft	CN-HS-C7
		20 m 65.617 ft	CN-HS-C20
L-shaped connector		3 m 9.843 ft	CN-HS-C3L
		7 m 22.966 ft	CN-HS-C7L
		20 m 65.617 ft	CN-HS-C20L

Controllers



Type		Appearance	Model No.	Output	Maximum number of connectable controllers
Master unit	High performance type (analog current) + input / output		HG-SC101	NPN open-collector transistor	Up to 15 slave units can be connected per master unit (Note)
			HG-SC101-P	PNP open-collector transistor	
Slave units	High performance type (analog current) + input / output		HG-SC111	NPN open-collector transistor	
			HG-SC111-P	PNP open-collector transistor	
	Standard type (input / output)		HG-SC112	NPN open-collector transistor	
			HG-SC112-P	PNP open-collector transistor	
Wire-saving type			HG-SC113	—	

Note: When connected to a communication unit for digital displacement sensor, up to 14 slave units can be connected per master unit.

FIBER SENSORS
LASER SENSORS
PHOTO-ELECTRIC SENSORS
MICRO PHOTO-ELECTRIC SENSORS
AREA SENSORS
SAFETY LIGHT CURTAINS / SAFETY COMPONENTS
PRESSURE / FLOW SENSORS
INDUCTIVE PROXIMITY SENSORS
PARTICULAR USE SENSORS
SENSOR OPTIONS
SIMPLE WIRE-SAVING UNITS
WIRE-SAVING SYSTEMS
MEASURE-MENT SENSORS
STATIC CONTROL DEVICES
LASER MARKERS
PLC
HUMAN MACHINE INTERFACES
ENERGY MANAGEMENT SOLUTIONS
FA COMPONENTS
MACHINE VISION SYSTEMS
UV CURING SYSTEMS

Selection Guide
Laser Displacement
Magnetic Displacement
Contact Displacement
Collimated Beam Sensors
Metal-sheet Double-feed Detection
Digital Panel Controller
Other Products
HG-S









ORDER GUIDE**Communication units for digital displacement sensors**

Designation	Appearance	Model No.	Description
Communication unit for CC-Link IE Field		SC-HG1-CEF	Can directly send high-precision measurement values to a CC-Link IE Field host device. <ul style="list-style-type: none"> • Communication method CC-Link IE Field • Number of connected units Host (CC-Link IE Field): Max. 121 units (1 master station, 120 slave stations) Controllers: Maximum of 15 units (1 master, 14 slaves) per SC-HG1-CEF unit
Communication unit for CC-Link		SC-HG1-C	Can directly send high-precision measurement values to CC-Link Master. <ul style="list-style-type: none"> • Communication method Switchable CC-Link Ver.1.10 or 2.00 • Number of occupied station CC-Link Ver.1.10: 4 stations, CC-Link Ver.2.00: Switchable 2 or 4 stations • Number of connected units Controllers: Maximum of 15 units (1 master, 14 slaves) per SC-HG1-C unit
Communication unit for RS-485		SC-HG1-485	Can directly send high-precision measurement values by RS-485 communication <ul style="list-style-type: none"> • Communication protocol MODBUS (RTU / ASCII) / MEWTOCOL-COM • Number of connected units Host (RS-485): 1 to 99 units when MODBUS (RTU / ASCII) is used, 1 to 64 units when MEWTOCOL-COM is used Controllers: Maximum of 15 units (1 master, 14 slaves) per SC-HG1-485 unit

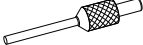
End plates

Designation	Appearance	Model No.	Description
End plates		MS-DIN-E 2 pcs. per set	Always use this when connecting controllers and a digital displacement sensor communication unit.

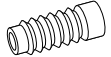
OPTIONS**Options (made-to-order)**

Designation	Appearance	Model No.	Description
Probe		TR-S10-C×5 5 pcs. per set	Standard type
		TR-S10-H	Super-hard type
		TR-S321-H	Super-hard needle type
		TR-S411-K	Flat-seated type
		TR-S601	Roller type
Joint		TR-J102	Length 15 mm 0.591 in type
		TR-J104	Length 25 mm 0.984 in type
Rubber bellows		TR-G20×5 5 pcs. per set	_____
Computer software for CC-Link / CC-Link IE Field		SC-PC1	This software makes it possible to use a computer to monitor current sensor values, save setting information to a CSV file, display log data, save log data to a CSV file, etc. Applicable models: SC-HG1-C , SC-HG1-CEF , SC-GU3-01 and SC-GU3-04 (Note)

Note: For **SC-GU3-01** and **SC-GU3-04**, refer to the communication unit for open network **SC-GU3** series (p.971~).

FIBER
SENSORSLASER
SENSORSPHOTO-
ELECTRIC
SENSORSMICRO
PHOTO-
ELECTRIC
SENSORSAREA
SENSORSSAFETY LIGHT
CURTAINS/
SAFETY
COMPONENTSPRESSURE /
FLOW
SENSORSINDUCTIVE
PROXIMITY
SENSORSPARTICULAR
USE
SENSORSSENSOR
OPTIONSSIMPLE
WIRE-SAVING
UNITSWIRE-SAVING
SYSTEMSMEASURE-
MENT
SENSORSSTATIC
CONTROL
DEVICESLASER
MARKERS

PLC

HUMAN
MACHINE
INTERFACESENERGY
MANAGEMENT
SOLUTIONSFA
COMPONENTSMACHINE
VISION
SYSTEMSUV
CURING
SYSTEMSSelection
GuideLaser
DisplacementMagnetic
DisplacementContact
DisplacementCollimated
Beam
SensorsMetal-sheet
Double-feed
DetectionDigital Panel
ControllerOther
Products**HG-S**

SPECIFICATIONS

Sensor heads

Type		10 mm 0.394 in type				32 mm 1.260 in type
		General purpose		High precision		General purpose
		Standard	Low measuring force	Standard	Low measuring force	Standard
Item	Model No.	HG-S1010	HG-S1010R	HG-S1110	HG-S1110R	HG-S1032
CE marking directive compliance		EMC Directive, RoHS Directive				
Compatible controller		HG-SC101(-P), HG-SC111(-P), HG-SC112(-P), HG-SC113				
Position detection method		Optical absolute linear encoder method				
Measurement range		10 mm 0.394 in				32 mm 1.260 in
Stroke		10.5 mm 0.413 in or more				32.5 mm 1.280 in or more
Measuring force (Note 2)	Downward mount	1.65 N or less 1.10 N (Note 3)	0.35 N or less 0.30 N (Note 3)	1.65 N or less 1.10 N (Note 3)	0.35 N or less 0.30 N (Note 3)	2.97 N or less 1.90 N (Note 3)
	Upward mount	1.35 N or less 0.85 N (Note 3)	—	1.35 N or less 0.85 N (Note 3)	—	2.09 N or less 1.19 N (Note 3)
	Side mount	1.50 N or less 0.95 N (Note 3)	0.25 N or less 0.20 N (Note 3)	1.50 N or less 0.95 N (Note 3)	0.25 N or less 0.20 N (Note 3)	2.53 N or less 1.50 N (Note 3)
Resolution		0.5 µm 0.020 mil		0.1 µm 0.004 mil		0.5 µm 0.020 mil
Sampling period		1 ms				
Indication accuracy (P-P)		Full range: 2.0 µm 0.079 mil or less Narrow range: 1.0 µm 0.039 mil or less (any 60 µm 2.362 mil)		Full range: 1.0 µm 0.039 mil or less Narrow range: 0.5 µm 0.020 mil or less (any 60 µm 2.362 mil)		Full range: 3.0 µm 0.118 mil or less Narrow range: 2.0 µm 0.079 mil or less (any 60 µm 2.362 mil)
Tip deviation amount		35 µm 1.378 mil (typical) (Note 4)				40 µm 1.575 mil (typical) (Note 4)
Hot swap function		Incorporated				
Operation indicator		2-color LED (Orange / Green)				
Environmental resistance	Protection	IP67 (IEC) (Note 5)	—	IP67 (IEC) (Note 5)	—	IP67 (IEC) (Note 5)
	Ambient temperature	-10 to +55 °C +14 to +131 °F (No condensation or icing allowed), Storage: -20 to +60 °C -4 to +140 °F				
	Ambient humidity	35 to 85 % RH, Storage: 35 to 85 % RH				
	Insulation resistance	100 MΩ or more at 250 V DC				
	Vibration resistance	10 to 500 Hz frequency (HG-S1032: 10 to 150 Hz frequency), 3 mm 0.118 in double amplitude (Maximum acceleration 196 m/s ²) in X, Y and Z directions for two hours each				
	Shock resistance	1,960 m/s ² acceleration in X, Y and Z directions three times each				
Mounting nut tightening strength		12.5 N·m				15 N·m
Probe tightening torque		0.1 to 0.4 N·m (no force applied to main unit)				
Grounding method		Capacitor grounding				
Material		Body: Zinc (HG-S1032: Aluminum), Holder: Stainless steel, Spindle: Tool steel (HG-S1032: Free-cutting steel), Probe (Note 6): Ceramic, Rubber bellows: NBR (black)				
Weight		Net weight: 80 g approx.				Net weight: 150 g approx.
Accessories		Standard type (HG-S1010 / HG-S1110 / HG-S1032): Sensor head fastening wrench 1 pc., Mounting nut 1 pc. Low measuring force type (HG-S1010R / HG-S1110R): Sensor head fastening wrench 1 pc., Mounting nut 1 pc., Rubber bellows 1 pc.				

- Notes: 1) Where measurement conditions have not been specified precisely, the conditions used were as follows: standard type measurement probe (TR-S10-C), ambient temperature +20 °C +68 °F, and a clean atmosphere where dust and liquids such as water and oil do not come in contact with the equipment.
2) In the case of low measurement force type (HG-S1010R / HG-S1110R), measurements were obtained with products in standard configuration without rubber bellows.
3) Typical value near center of measurement.
4) Value calculated from the clearance of the upper and lower plain bearings.
5) Excludes damage and deterioration to rubber bellows due to external causes.
6) The probes (optional) are also available.

SPECIFICATIONS**Controller**

Item	Model No.	Type	Master unit		Slave unit				
			NPN output	PNP output	High-performance type	High-performance type	Standard type	Wire-saving type	
			HG-SC101	HG-SC101-P	HG-SC111	HG-SC111-P	HG-SC112	HG-SC112-P	HG-SC113
CE marking directive compliance			EMC Directive, RoHS Directive						
Compatible sensor head			HG-S1010(R), HG-S1110(R), HG-S1032						
Number of connectable units			Up to 15 slave units can be connected per master unit. (Note 2)						
Supply voltage			24 V DC $\pm 10\%$, including ripple 0.5 V (P-P)						
Current consumption (Note 3)			70 mA or less (when sensor head is connected)						
Analog current output (Note 4)			Current output range: 4 to 20 mA/F.S. (default value) Error output: 0 mA Linearity: $\pm 0.25\%$ F.S. Load impedance: 250 Ω max.						
Control outputs (Output 1, Output 2, Output 3)			<NPN output type> NPN open-collector transistor • Maximum sink current: 50 mA (Note 5) • Applied voltage: 30 V DC or less (between output and 0 V) • Residual voltage: 1.5 V or less (at 50 mA sink current) • Leakage current: 0.1 mA or less		<PNP output type> PNP open-collector transistor • Maximum source current: 50 mA (Note 5) • Applied voltage: 30 V DC or less (between output and +V) • Residual voltage: 1.5 V or less (at 50 mA source current) • Leakage current: 0.1 mA or less				
Short-circuit protection			Incorporated (automatic reset type)						
Judgment output			NO / NC switching method						
Alarm output			Open when alarm occurs						
External inputs (Input 1, Input 2, Input 3)			<NPN output type> Non-contact input or NPN open-collector transistor • Input condition: Invalid (+8 V to +V DC or open) Valid (0 to +1.2 V DC) • Input impedance: 10 k Ω approx.		<PNP output type> Non-contact input or PNP open-collector transistor • Input condition: Invalid (0 to +0.6 V DC or open) Valid (+4 V to +V DC) • Input impedance: 10 k Ω approx.				
Trigger input			Input time 2 ms or more (ON)						
Preset input			Input time 20 ms or more (ON)						
Reset input			Input time 20 ms or more (ON)						
Bank input A / B (Note 6)			Input time 20 ms or more (ON)						
Response time			3 ms, 5 ms, 10 ms, 100 ms, 500 ms, 1,000 ms switching type						
Digital display			204-segment LCD						
Display resolution			0.1 μm 0.004 mil						
Display range			-199.9999 to 199.9999 mm -7.874 to 7.874 in						
Contamination level			2						
Elevation			2,000 m 6561.68 ft or less (Note 7)						
Environmental resistance			IP40 (IEC)						
Protection			IP40 (IEC)						
Ambient temperature			-10 to +50 °C +14 to +122 °F (No dew condensation or icing allowed) (Note 5), Storage: -20 to +60 °C -4 to +140 °F						
Ambient humidity			35 to 85 % RH, Storage: 35 to 85 % RH						
Voltage withstandability			1,000 V AC for one min. between all supply terminals connected together and enclosure						
Insulation resistance			20 M Ω , or more, with 250 V DC megger between all supply terminals connected together and enclosure						
Vibration resistance			10 to 150 Hz frequency, 0.75 mm 0.030 in double amplitude (Maximum acceleration 49 m/s ²) in X, Y and Z directions for two hours each						
Shock resistance			98 m/s ² acceleration (10 G approx.) in X, Y and Z directions five times each						
Material			Case: Polycarbonate, Cover: Polycarbonate, Switches: Polyacetal						
Cable			0.2 mm ² 2-core cable (brown and blue lead wires) / 0.15 mm ² 7-core composite cable, 2 m 6.562 ft long	0.15 mm ² , 7-core composite cable, 2 m 6.562 ft long	0.15 mm ² , 6-core cabletyre cable, 2 m 6.562 ft long				
Weight			Net weight: 140 g approx.	Net weight: 140 g approx.	Net weight: 130 g approx.	Net weight: 60 g approx.			

Notes: 1) Where measurement conditions have not been specified precisely, the conditions used were as follows: supply voltage 24 V DC, ambient temperature +20 °C **+68 °F**.

2) When connected to a communication unit for digital displacement sensor, up to 14 slave units can be connected per master unit.

3) Current consumption does not include analog current output.

4) Linearity F.S. = 16 mA, and is linearity with respect to digitally measured values.

5) When slave units are connected to the master unit, the maximum sink current / source current of the control output and ambient temperature vary depending on the number of connected slave units as shown below.

Number of connected slave units	Maximum sink current / source current of control output	Ambient temperature
1 to 7 units	20 mA	-10 to +45 °C +14 to +113 °F
8 to 15 units	10 mA	

6) Banks 1 to 3 can be selected by switching bank input A / B.

7) Do not use or store in an environment that has been pressurized to an air pressure higher than the atmospheric pressure at 0 m.

FIBER
SENSORSLASER
SENSORSPHOTO-
ELECTRIC
SENSORSMICRO
PHOTO-
ELECTRIC
SENSORSAREA
SENSORSSAFETY LIGHT
CURTAINS/
SAFETY
COMPONENTSPRESSURE /
FLOW
SENSORSINDUCTIVE
PROXIMITY
SENSORSPARTICULAR
USE
SENSORSSENSOR
OPTIONSSIMPLE
WIRE-SAVING
UNITSWIRE-SAVING
SYSTEMSMEASURE-
MENT
SENSORSSTATIC
CONTROL
DEVICESLASER
MARKERS

PLC

HUMAN
MACHINE
INTERFACESENERGY
MANAGEMENT
SOLUTIONSFA
COMPONENTSMACHINE
VISION
SYSTEMSUV
CURING
SYSTEMSSelection
GuideLaser
DisplacementMagnetic
DisplacementContact
DisplacementCollimated
Beam
SensorsMetal-sheet
Double-feed
DetectionDigital Panel
ControllerOther
Products**HG-S**

SPECIFICATIONS

Communication units for digital displacement sensors

Designation	Communication unit for CC-Link IE Field	
Item	Model No.	SC-HG1-CEF
CE marking directive compliance	EMC Directive, RoHS Directive	
Compatible controllers	HG-SC □	
Maximum number of connectable controllers	Maximum of 15 controllers (one master, 14 slaves) per SC-HG1-CEF unit	
Supply voltage (Note 2)	24 V DC ±10%, including ripple 0.5 V (P-P)	
Current consumption	200 mA or less	
Communication method	CC-Link IE Field	
Remote station type	Remote device station	
Network No. setting	1 to 239 (decimal) [1 to EF (hex)] (0 and 240 or more: Error) (Note 3)	
Cyclic transmission (Maximum number of links per station)	RX / RY: 128 points each (128 bits), 16 bytes RW r / RWw: 64 points each (64 words), 128 bytes	
Transient transmission	Server function only, data size 1,024 bytes	
Station No. setting	1 to 120 (decimal) (0 and 121 or more: Error)	
Baud rate	1 Gbps	
Transmission line types	Line, star (mixing of line and star types is possible), ring	
Maximum transmission distance	100 m 328.084 ft	
Maximum number of connectable units	121 units (1 master station, 120 slave stations)	
Cascade connection levels	Maximum 20	
Pollution degree	2	
Operating altitude	2,000 m 6561.680 ft or less (Note 4)	
Environmental resistance	Protection	IP40 (IEC)
	Ambient temperature	-10 to +45 °C +14 to +113 °F (No dew condensation or icing allowed) Storage: -20 to +60 °C -4 to +140 °F
	Ambient humidity	35 to 85 % RH, Storage: 35 to 85 % RH
	Voltage withstandability	1,000 V AC for one min. between all supply terminals connected together and enclosure
	Insulation resistance	20 MΩ or more, with 250 V DC megger between all supply terminals connected together and enclosure
	Vibration resistance	10 to 150 Hz frequency, 0.75 mm 0.030 in double amplitude in X, Y and Z directions for two hours each
	Shock resistance	98 m/s ² acceleration (10 G approx.) in X, Y and Z directions five times each
Material	Enclosure: Polycarbonate	
Communication cable	Ethernet cable that satisfies 1000BASE-T standard Category 5e or higher (Double-shielded / STP, straight cable) (Note 5)	
Weight	Net weight: 100 g approx., Gross weight: 150 g approx.	

- Notes: 1) Where measurement conditions have not been specified precisely, the conditions used were an ambient temperature of +20 °C **+68 °F**.
 2) Power is supplied from a connected controller / master controller.
 3) For the network No. setting on this product, convert the network number to hex and set the hex value.
 4) Do not use or store in an environment that has been pressurized to an air pressure higher than the atmospheric pressure at 0 m.
 5) Use CC-Link Partner Association recommended cable.

Designation	Communication unit for CC-Link						
Item	Model No.	SC-HG1-C					
CE marking directive compliance	EMC Directive (Note 2), RoHS Directive						
Compatible controllers	HG-SC □						
Maximum number of connectable controllers	Maximum of 15 controllers (one master, 14 slaves) per SC-HG1-C unit						
Supply voltage (Note 3)	24 V DC ±10 %, including ripple 0.5 V (P-P)						
Current consumption	80 mA or less						
Communication method	Switchable CC-Link Ver.1.10 or 2.00						
Remote station type	Remote device station						
Number of occupied station	CC-Link Ver.1.10: 4 stations, CC-Link Ver.2.00: Switchable 2 or 4 stations						
Station No. setting	1 to 64 (0 and 65 or more: Error)						
Baud rate	10 Mbps	5 Mbps	2.5 Mbps	625 kbps	156 kbps		
Maximum transmission distance	100 m 328.084 ft	160 m 524.934 ft	400 m 1,312.336 ft	900 m 2,952.756 ft	1,200 m 3,937.008 ft		
Pollution degree	2						
Operating altitude	2,000 m 6561.680 ft or less (Note 4)						
Environmental resistance	Protection	IP40 (IEC)					
	Ambient temperature	-10 to +45 °C +14 to +113 °F (No dew condensation or icing allowed), Storage: -20 to +60 °C -4 to +140 °F					
	Ambient humidity	35 to 85 % RH, Storage: 35 to 85 % RH					
	Voltage withstandability	1,000 V AC for one min. between all supply terminals connected together and enclosure					
	Insulation resistance	20 MΩ or more, with 250 V DC megger between all supply terminals connected together and enclosure					
	Vibration resistance	10 to 150 Hz frequency, 0.75 mm 0.030 in double amplitude in X, Y and Z directions for two hours each					
	Shock resistance	98 m/s ² acceleration (10 G approx.) in X, Y and Z directions five times each					
Material	Enclosure: Polycarbonate						
Communication cable	Specified cable (shielded twisted cable) (Note 5)						
Weight	Net weight: 80 g approx., Gross weight: 130 g approx.						

- Notes: 1) Where measurement conditions have not been specified precisely, the conditions used were an ambient temperature of +20 °C **+68 °F**.
 2) If our product will be incorporated in a customer product that will comply with the EMC Directive, install our product in a conductive box in accordance with "PLC User's Manual [Published by Mitsubishi Electric Corporation]".
 3) Power is supplied from a connected controller / master controller.
 4) Do not use or store in an environment that has been pressurized to an air pressure higher than the atmospheric pressure at 0 m.
 5) Use only a special-use communication cable that is approved by the CC-Link Partner Association.

Designation	Communication unit for RS-485	
Item	Model No.	SC-HG1-485
CE marking directive compliance	EMC Directive, RoHS Directive	
Compatible controllers	HG-SC □	
Supply voltage (Note 2)	24 V DC ±10 %, Ripple P-P 10 % or less (Within specified power supply voltage range)	
Current consumption	40 mA or less	
Communication method	Two-wire half duplex communication	
Synchronization method	Start-stop synchronization	
Communication protocol	MODBUS (RTU / ASCII) / MEWTOCOL-COM	
Baud rate	1.2 kbps / 2.4 kbps / 4.8 kbps / 9.6 kbps / 19.2 kbps / 38.4 kbps / 57.6 kbps / 115.2 kbps	
Electrical characteristics	Complies with EIA RS-485	
Number of connectable units	Host (RS-485)	1 to 99 units when MODBUS (RTU / ASCII) is used, 1 to 64 units when MEWTOCOL-COM is used
	Sensors	Maximum of 15 controllers (1 master, 14 slaves) per SC-HG1-485 unit
Stop bit length	1 bit / 2 bits	
Parity check	Even / Odd / None	
Data bit length	8 bits (RTU) / 7 bits (ASCII)	
Pollution degree	2	
Operating altitude	2,000 m 6561.68 ft or less (Note 3)	
Environmental resistance	Protection	IP40 (IEC)
	Ambient temperature	-10 to +45 °C 14 to +113 °F (No dew condensation or icing allowed), Storage: -20 to +60 °C -4 to +140 °F
	Ambient humidity	35 to 85 % RH, Storage: 35 to 85 % RH
	Voltage withstandability	1,000 V AC for one min. between all supply terminals connected together and enclosure
	Insulation resistance	20 MΩ, or more, with 250 V DC megger between all supply terminals connected together and enclosure
	Vibration resistance	10 to 150 Hz frequency, 0.75 mm 0.030 in double amplitude in X, Y and Z directions for two hours each
	Shock resistance	98 m/s ² acceleration (10 G approx.) in X, Y and Z directions five times each
Material	Enclosure: Polycarbonate	
Total extension distance	Communication cable: 1,200 m 3,937.008 ft or less between SC-HG1-485 (terminal) and PLC	
Weight	Net weight: 75 g approx., Gross weight: 120 g approx.	
Accessory	Termination resistor switching jumper pin: 1 pc.	

- Notes: 1) Where measurement conditions have not been specified precisely, the conditions used were an ambient temperature of +20 °C **+68 °F**.
 2) Power is supplied from a connected controller / master controller.
 3) Do not use or store in an environment that has been pressurized to an air pressure higher than the atmospheric pressure at 0 m.

- FIBER SENSORS
- LASER SENSORS
- PHOTO-ELECTRIC SENSORS
- MICRO PHOTO-ELECTRIC SENSORS
- AREA SENSORS
- SAFETY LIGHT CURTAINS / SAFETY COMPONENTS
- PRESSURE / FLOW SENSORS
- INDUCTIVE PROXIMITY SENSORS
- PARTICULAR USE SENSORS
- SENSOR OPTIONS
- SIMPLE WIRE-SAVING UNITS
- WIRE-SAVING SYSTEMS
- MEASURE-HEXIT SENSORS
- STATIC CONTROL DEVICES
- LASER MARKERS
- PLC
- HUMAN MACHINE INTERFACES
- ENERGY MANAGEMENT SOLUTIONS
- FA COMPONENTS
- MACHINE VISION SYSTEMS
- UV CURING SYSTEMS
- Selection Guide
- Laser Displacement
- Magnetic Displacement
- Contact Displacement
- Collimated Beam Sensors
- Metal-sheet Double-feed Detection
- Digital Panel Controller
- Other Products
- HG-S**

I/O CIRCUIT DIAGRAMS

For communication unit for digital displacement sensors, refer to the User's Manual.
The User's Manual can be downloaded from our website.

NPN output type

HG-SC101 / Master unit

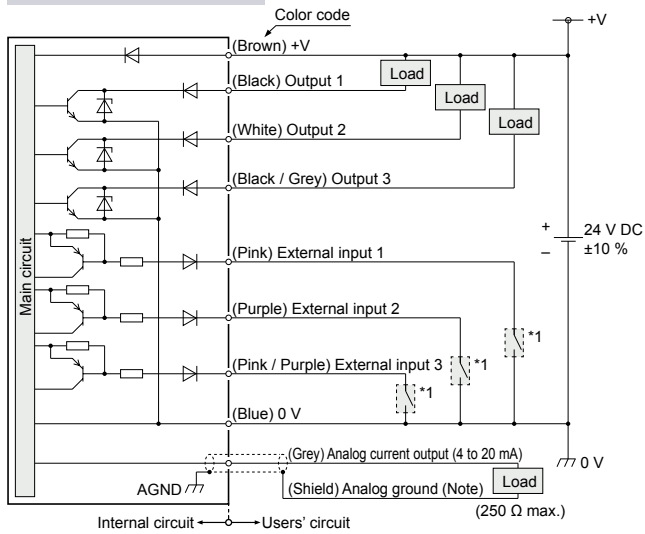

HG-SC111 / Slave unit

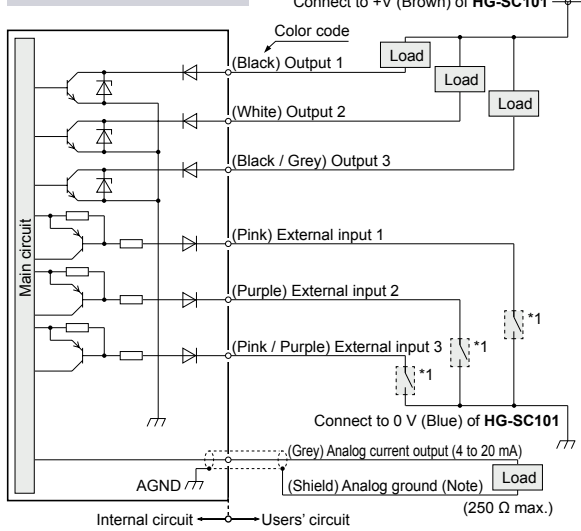

HG-SC112 / Slave unit

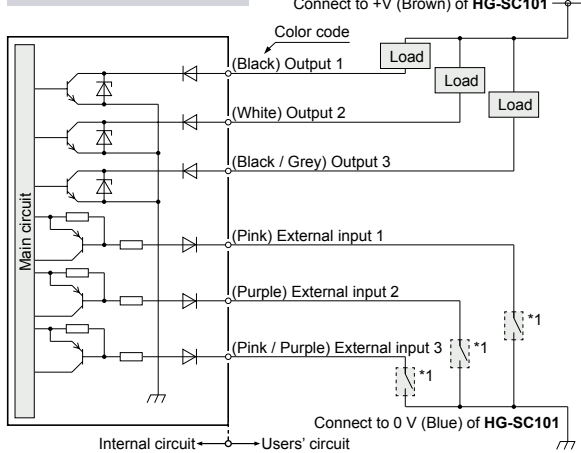

* 1

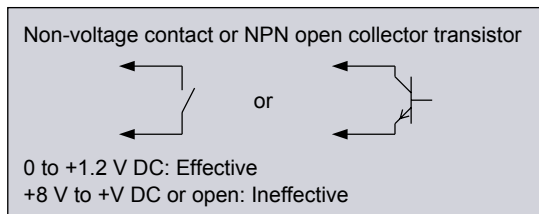

Note: Use shielded wire for the analog output.

PNP output type

HG-SC101-P / Master unit

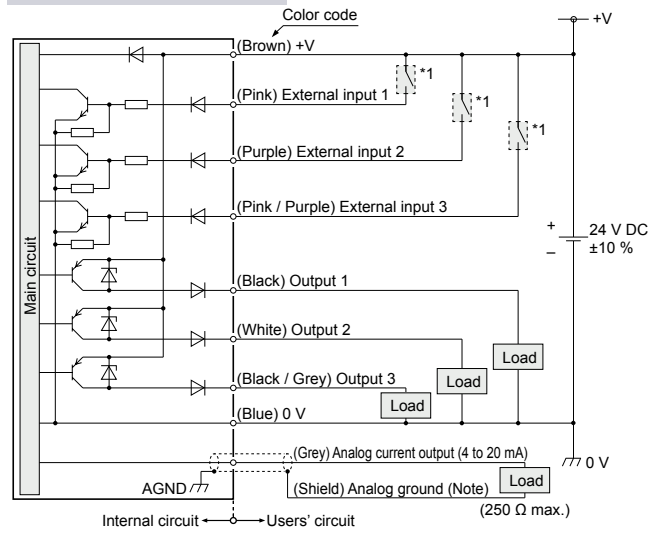

HG-SC111-P / Slave unit

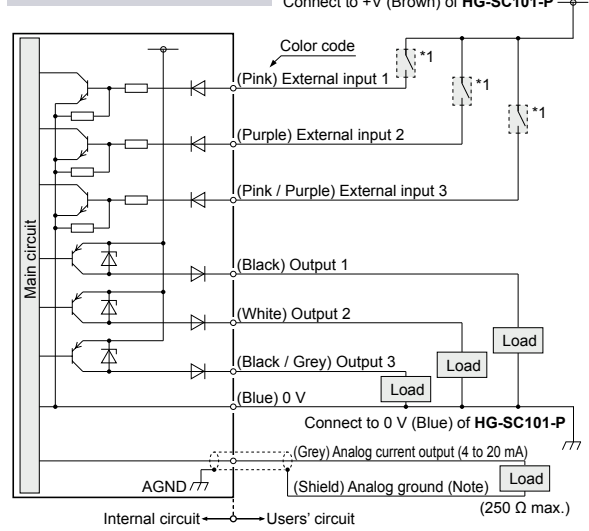

HG-SC112-P / Slave unit

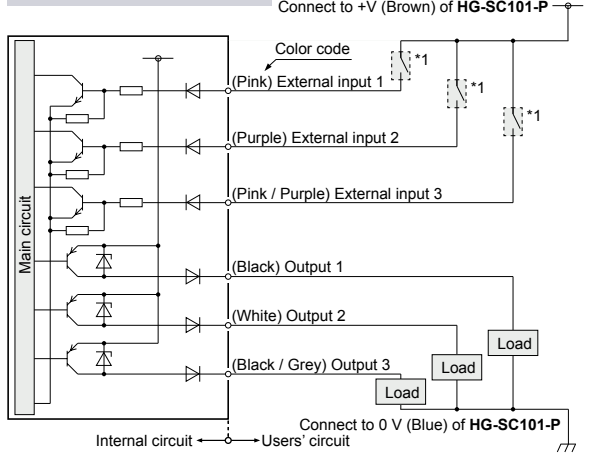

* 1

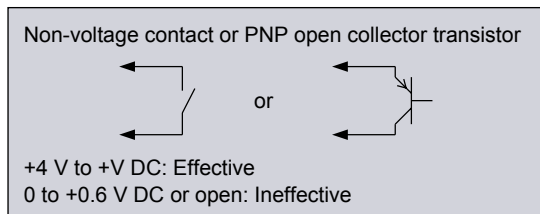

Note: Use shielded wire for the analog output.

FIBER SENSORS

LASER SENSORS

PHOTO-ELECTRIC SENSORS

MICRO PHOTO-ELECTRIC SENSORS

AREA SENSORS

SAFETY LIGHT CURTAINS/ SAFETY COMPONENTS

PRESSURE / FLOW SENSORS

INDUCTIVE PROXIMITY SENSORS

PARTICULAR USE SENSORS

SENSOR OPTIONS

WIRE- SAVING UNITS

WIRE- SAVING SYSTEMS

MEASURE- MENT SENSORS

STATIC CONTROL DEVICES

LASER MARKERS

PLC

HUMAN MACHINE INTERFACES

ENERGY MANAGEMENT SOLUTIONS

FA COMPONENTS

MACHINE VISION SYSTEMS

UV CURING SYSTEMS

Selection Guide

Laser Displacement

Magnetic Displacement

Contact Displacement

Collimated Beam Sensors

Metal-sheet Double-feed Detection

Digital Panel Controller

Other Products

HG-S

- FIBER SENSORS
- LASER SENSORS
- PHOTO-ELECTRIC SENSORS
- MICRO PHOTO-ELECTRIC SENSORS
- AREA SENSORS
- SAFETY LIGHT CURTAINS / SAFETY COMPONENTS
- PRESSURE / FLOW SENSORS
- INDUCTIVE PROXIMITY SENSORS
- PARTICULAR USE SENSORS
- SENSOR OPTIONS
- SIMPLE WIRE-SAVING UNITS
- WIRE-SAVING SYSTEMS
- MEASURE-MENT SENSORS
- STATIC CONTROL DEVICES
- LASER MARKERS
- PLC
- HUMAN MACHINE INTERFACES
- ENERGY MANAGEMENT SOLUTIONS
- FA COMPONENTS
- MACHINE VISION SYSTEMS
- UV CURING SYSTEMS
- Selection Guide
- Laser Displacement
- Magnetic Displacement
- Contact Displacement
- Collimated Beam Sensors
- Metal-sheet Double-feed Detection
- Digital Panel Controller
- Other Products
- HG-S**

Refer to the user's manual for details. The user's manual can be downloaded from our website. Refer to p.1595 for general precautions.

PRECAUTIONS FOR PROPER USE



- Never use this product as a sensing device for personnel protection.
- When using sensing devices for personnel protection, use products that meet the laws and standards for personnel protection that apply in each region or country, such as OSHA, ANSI and IEC.

• This catalog has been prepared to aid selection of appropriate products. When using the product, be sure to read the user's manual.

Part description

Standard type

<Standard type>
(HG-S1010 / HG-S1110)

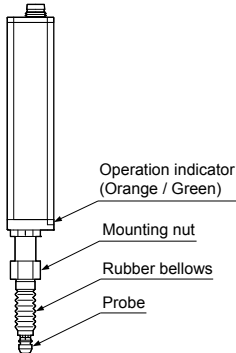
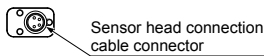

<Standard type>
(HG-S1032)

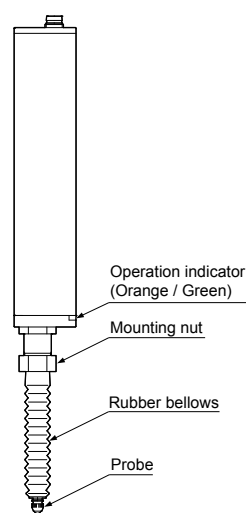
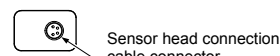

<Low measuring force type>
(HG-S1010R / HG-S1110R)

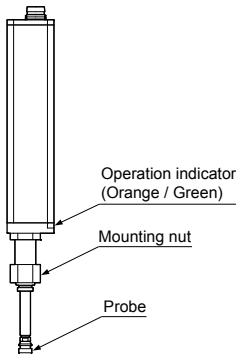
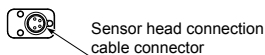

Controller

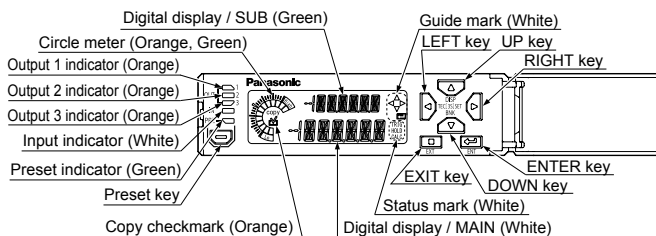
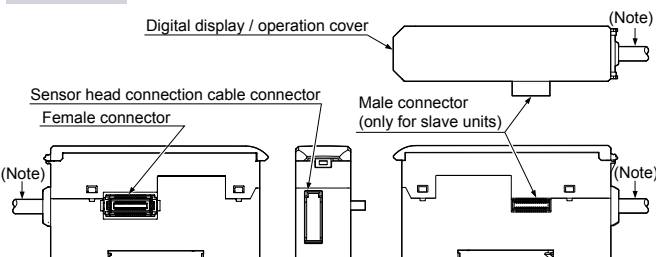

Note: Not provided on slave units or wire-saving type (HG-SC113).

Sensor head

Mounting

- When tightening the nut, take care not to damage the rubber bellows.
- If the rubber bellows is deformed, a load will occur when the spindle operates and damage may result.
- Do not remove the rubber bellows from the standard type products (HG-S1010 / HG-S1110 / HG-S1032) except for when replacing them. Unnecessary removal of rubber bellows can result in entry of dust and water, thus causing malfunction.

1. Open a hole in the housing in which the sensor head will be mounted.

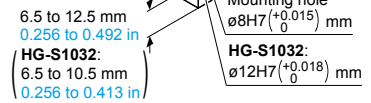

2. Insert the sensor head into the hole you opened in the housing, and fasten provisionally with the provided mounting nut.

Note: The orientation of the mounting nut depends on the thickness of the housing. For details, refer to **DIMENSIONS** (p.1107~).

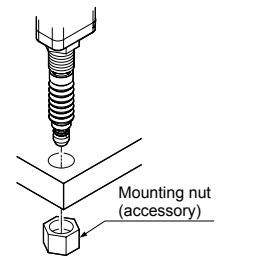

3. Fasten the sensor head. When fastening the sensor head, tighten the mounting nut with a wrench while holding the sensor head in place with the provided sensor head fastening wrench as shown right. Tighten to a torque of 12.5 N·m or less. (HG-S1032: 15 N·m or less)

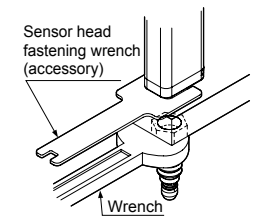

4. Make sure that the rubber bellows has not become deformed as shown right. If the rubber bellows is deformed, restore the normal shape by rotating the bellows or otherwise.

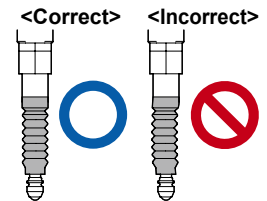

Attaching the sensor head connection cable

- When disconnecting, always make sure that the fastening ring has been completely loosened before pulling out the cable.
- Risk of damage if you pull the cable with excessive force (15 N or more) with the fastening ring tightened.

Mounting

1. Insert the sensor head connection cable into the connector for the sensor head connection cable on the sensor head.
2. Turn the fastening ring on the sensor head connector in the direction shown to fasten the ring.

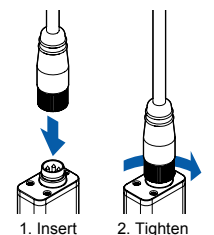

Removal method

1. Turn the fastening ring on the sensor head connector in the direction of the arrow to loosen the ring.
2. Grasp the sensor head connector and pull up to remove.

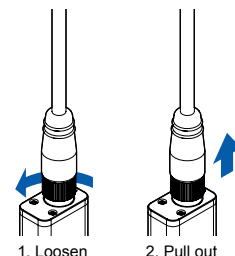

PRECAUTIONS FOR PROPER USE

Refer to the user's manual for details. The user's manual can be downloaded from our website.
Refer to p.1595 for general precautions.

Controller**Mounting****Mounting**

1. Insert the rear of the mounting part into the DIN rail.
2. While pressing down on the rear of the mounting part, insert the front of the mounting part into the DIN rail.

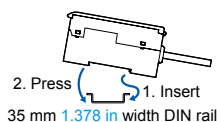
**Removal method**

1. Grasp the product and push forward.
2. Lift the front to remove.

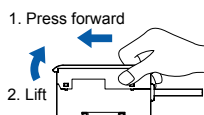
**Attaching the sensor head connection cable****Mounting**

1. Insert the sensor head connection cable into the connector for the sensor head connection cable on the controller.

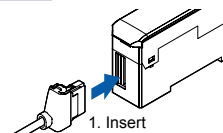
**Removal method**

1. Grasp the controller, and while pressing on the lock release lever on the connector of the sensor head connection cable, pull toward you to disconnect.

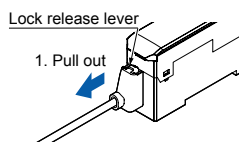

Note: If you attempt to disconnect the cable by pulling it without pressing the lock release lever, cable wire breakage and connector damage may occur.

Connection

- Always shut off the power before connecting a slave unit to or disconnecting a slave unit from the master unit. Risk of controller damage if you attempt connection with the power on.
- Insert the male connector firmly into the female connector. Risk of controller damage if not completely connected.
- To connect units, the units must be mounted on a DIN rail. Attach end plates **MS-DIN-E** (optional) so as to enclose the connected units at the ends.
- Up to 15 slave units (up to 14 slave units when a communication unit for digital displacement sensor is connected) can be connected per master unit.
- When connecting slave units to a master unit, connect only NPN output types, or only PNP output types. Dissimilar output types cannot be connected together.

Connection method

1. Mount one master unit on the DIN rail.
2. Remove the connector cover.
3. Mount each slave unit one at a time on the DIN rail. Remove all connector covers except for the cover on the end slave unit.
4. Slide each slave unit to connect the female and male connectors.
5. Attach end plates **MS-DIN-E** (optional) with the flat side facing in so as to enclose the connected units at the ends.
6. Tighten the screws to fasten the end plates.

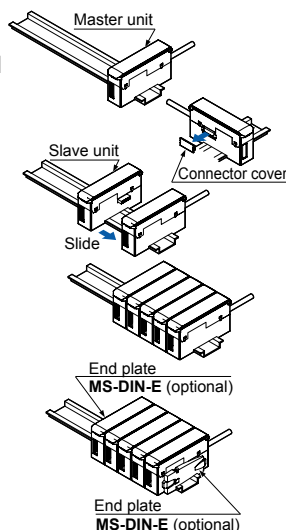
**Removal method**

1. Loosen the screws on the end plates
2. Remove the end plates.
3. Slide and remove the controllers, one at a time.

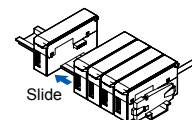
**Common****Wiring**

- The product is designed to fulfill the specifications when combined with the **HG-S** sensor head and **HG-SC** controller. If the product is used in combination with other products, it not only fails to meet the specifications but also generates a malfunction in some cases.
- For the controller DC power supply, only use a power supply that is isolated by means of an isolation transformer or otherwise.
- Risk of short-circuiting and damage to the controller or power supply if a transformer such as an auto transformer is used. Risk of short-circuiting and damage to the controller or power supply if incorrectly mounted or connected.

- Make sure that the power supply is off while performing wiring or expansion work.
- After you have completed wiring work, check the wiring carefully before switching on the power.
- Do not run the wires together with high-voltage lines or power lines or put them in the same raceway. This can cause malfunction due to induction.
- Verify that the supply voltage variation is within the rating.
- If power is supplied from a commercial switching regulator, ensure that the frame ground (F.G.) terminal of the power supply is connected to an actual ground.
- Do not use during the initial transient time after the power supply is switched on.
- Make sure that stress by forcible bend or pulling is not applied directly to the sensor cable joint.

Others

- This device has been developed / produced for industrial use only.
- Do not use this product outside the range of the specifications. Risk of an accident and product damage. There is also a risk of a noticeable reduction of service life.
- This controller uses an EEPROM. The EEPROM has a service life of one million setting operations.
- This product is suitable for indoor use only.
- Avoid dust, dirt, and steam.
- Take care that the product does not come in direct contact with organic solvents such as thinner.
- Take care that the product does not come in direct contact with strong acid or alkaline.
- Take care that the product does not come in direct contact with oil or grease.
- Do not use in an environment containing inflammable or explosive gases.
- Performance may not be satisfactory in a strong electromagnetic field.
- This product is a precision device. Do not drop or otherwise subject to shock. Risk of product damage.
- Never attempt to disassemble, repair, or modify the product.

FIBER SENSORS

LASER SENSORS

PHOTO-ELECTRIC SENSORS

MICRO PHOTO-ELECTRIC SENSORS

AREA SENSORS

SAFETY LIGHT CURTAINS / SAFETY COMPONENTS

PRESSURE / FLOW SENSORS

INDUCTIVE PROXIMITY SENSORS

PARTICULAR USE SENSORS

SENSOR OPTIONS

SIMPLE WIRE-SAVING UNITS

WIRE-SAVING SYSTEMS

MEASURE-MENT SENSORS

STATIC CONTROL DEVICES

LASER MARKERS

PLC

HUMAN MACHINE INTERFACES

ENERGY MANAGEMENT SOLUTIONS

FA COMPONENTS

MACHINE VISION SYSTEMS

UV CURING SYSTEMS

Selection Guide

Laser Displacement

Magnetic Displacement

Contact Displacement

Collimated Beam Sensors

Metal-sheet Double-feed Detection

Digital Panel Controller

Other Products

HG-S

DIMENSIONS (Unit: mm in)

The CAD data can be downloaded from our website.

- FIBER SENSORS
- LASER SENSORS
- PHOTO-ELECTRIC SENSORS
- MICRO PHOTO-ELECTRIC SENSORS
- AREA SENSORS
- SAFETY LIGHT CURTAINS / SAFETY COMPONENTS
- PRESSURE / FLOW SENSORS
- INDUCTIVE PROXIMITY SENSORS
- PARTICULAR USE SENSORS
- SENSOR OPTIONS
- SIMPLE WIRE-SAVING UNITS
- WIRE-SAVING SYSTEMS
- MEASURE-MENT SENSORS
- STATIC CONTROL DEVICES
- LASER MARKERS
- PLC
- HUMAN MACHINE INTERFACES
- ENERGY MANAGEMENT SOLUTIONS
- FA COMPONENTS
- MACHINE VISION SYSTEMS
- UV CURING SYSTEMS
- Selection Guide
- Laser Displacement
- Magnetic Displacement
- Contact Displacement
- Collimated Beam Sensors
- Metal-sheet Double-feed Detection
- Digital Panel Controller
- Other Products
- HG-S**

HG-S1010(R) HG-S1110(R)

Sensor head

**Standard type
HG-S1010 / HG-S1110**

**Low measuring force type
HG-S1010R / HG-S1110R**

Installation of sensor head connection cable

The diagrams show the sensor head connection cable connected to the low measurement type.

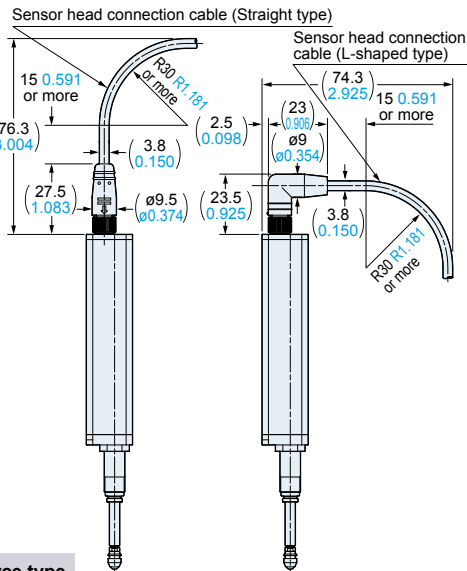
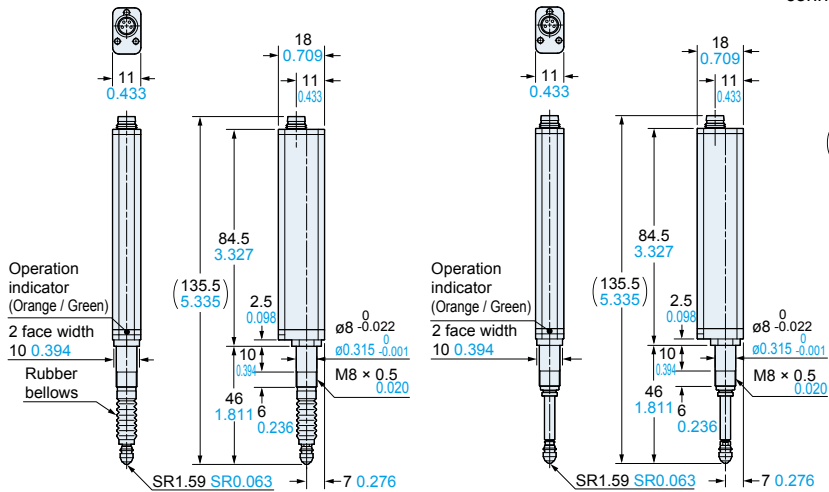

Installation of mounting nut attachment

**Standard type
HG-S1010 / HG-S1110**

**Low measuring force type
HG-S1010R / HG-S1110R**

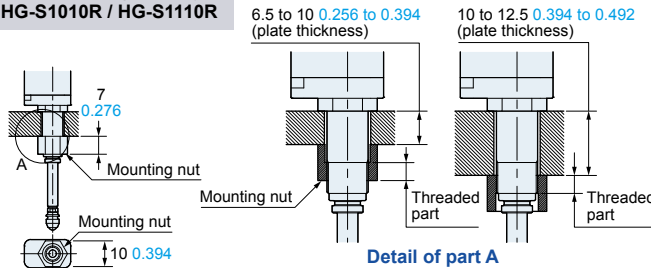
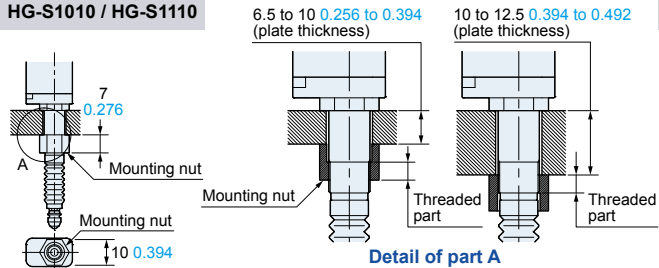

HG-S1032

Sensor head

Installation of mounting nut attachment

Installation of sensor head connection cable

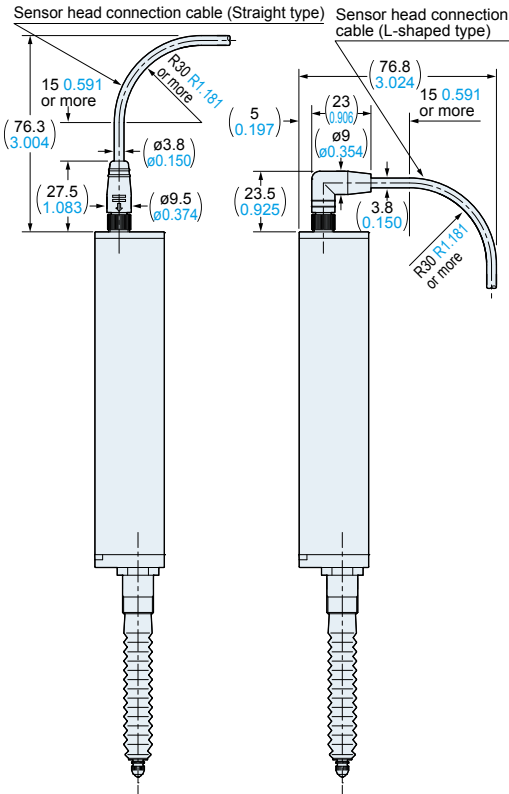
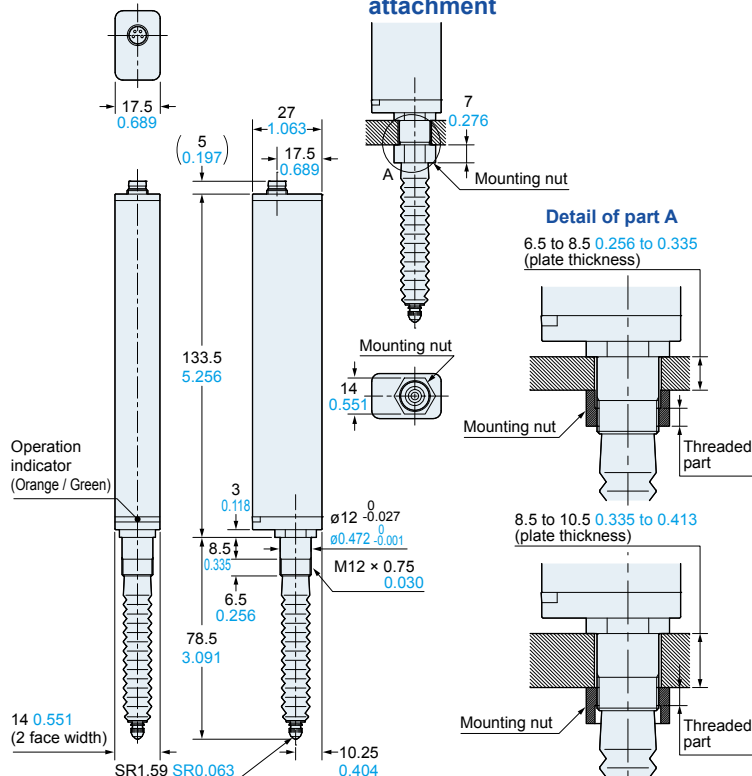

DIMENSIONS (Unit: mm in)

The CAD data can be downloaded from our website.

HG-SC101(-P)

Controller (Master unit)

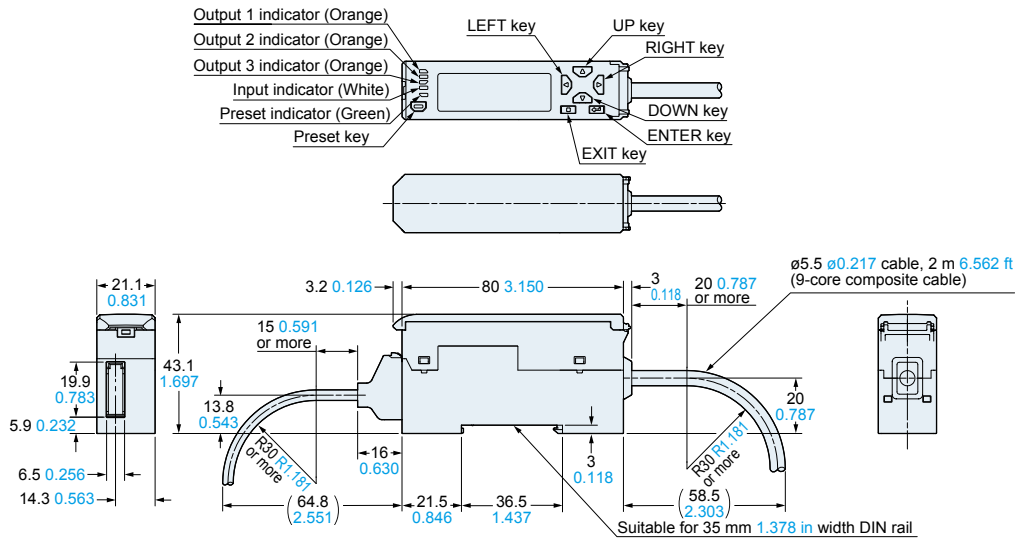

HG-SC111(-P) HG-SC112(-P)

Controller (Slave unit)

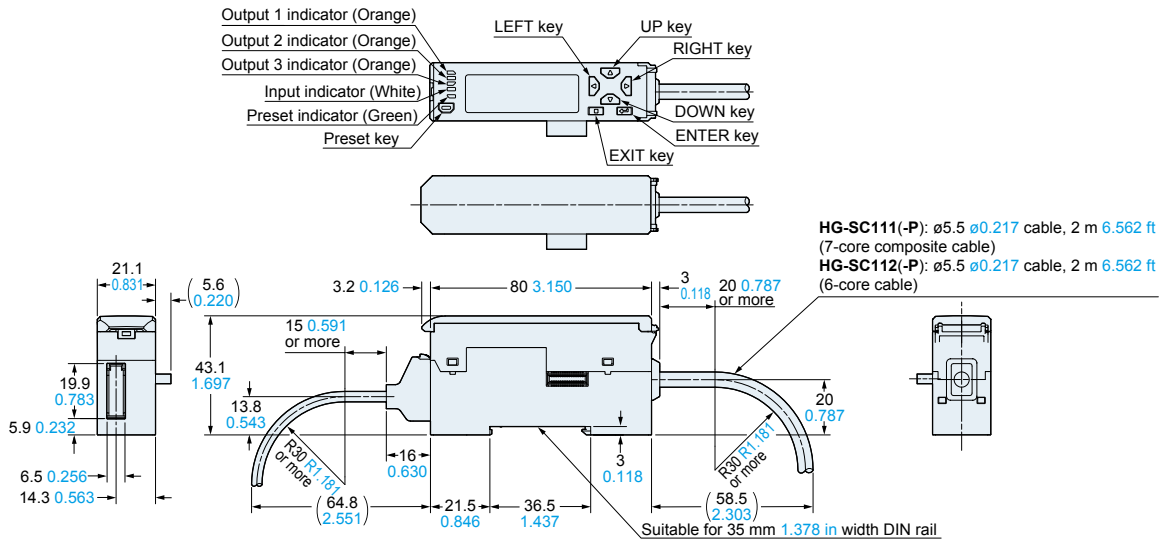

HG-SC113

Controller (Slave unit)

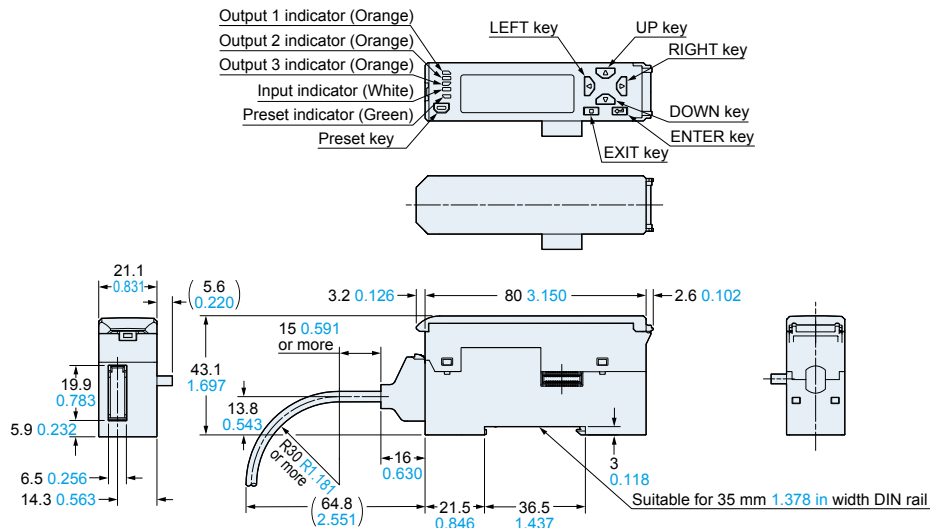

FIBER SENSORS

LASER SENSORS

PHOTO-ELECTRIC SENSORS

MICRO PHOTO-ELECTRIC SENSORS

AREA SENSORS

SAFETY LIGHT CURTAINS / SAFETY COMPONENTS

PRESSURE / FLOW SENSORS

INDUCTIVE PROXIMITY SENSORS

PARTICULAR USE SENSORS

SENSOR OPTIONS

SIMPLE WIRE-SAVING UNITS

WIRE-SAVING SYSTEMS

MEASURE-MENT SENSORS

STATIC CONTROL DEVICES

LASER MARKERS

PLC

HUMAN MACHINE INTERFACES

ENERGY MANAGEMENT SOLUTIONS

FA COMPONENTS

MACHINE VISION SYSTEMS

UV CURING SYSTEMS

Selection Guide

Laser Displacement

Magnetic Displacement

Contact Displacement

Collimated Beam Sensors

Metal-sheet Double-feed Detection

Digital Panel Controller

Other Products

HG-S

DIMENSIONS (Unit: mm in)

The CAD data can be downloaded from our website.

SC-HG1-CEF Communication unit for CC-Link IE Field

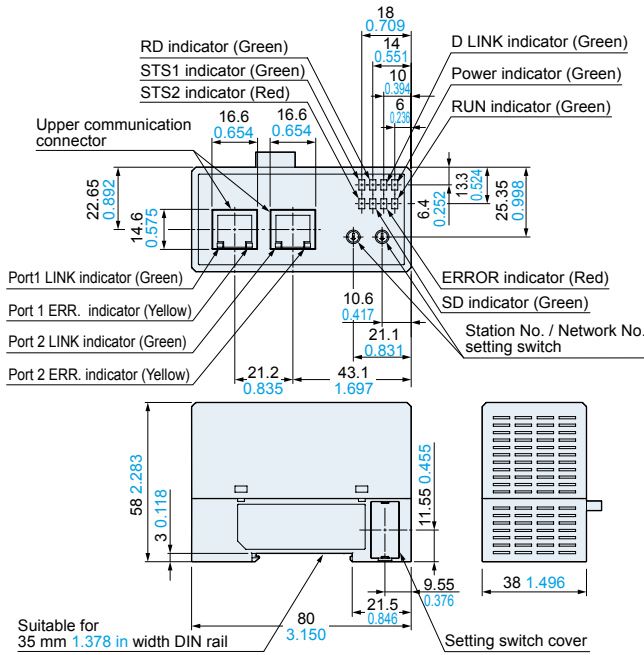

SC-HG1-485 Communication unit for RS-485

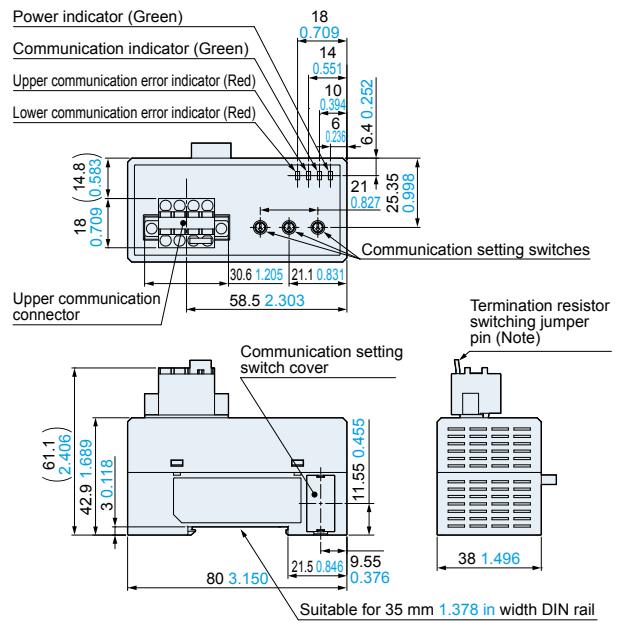

Note: The termination resistor switching jumper pin is not attached to the product at the factory. Attach the termination resistor switching jumper pin to the unit at the terminating end. Make sure that the termination resistor switching jumper pin have been removed from all units except the one at the terminating end.

SC-HG1-C Communication unit for CC-Link

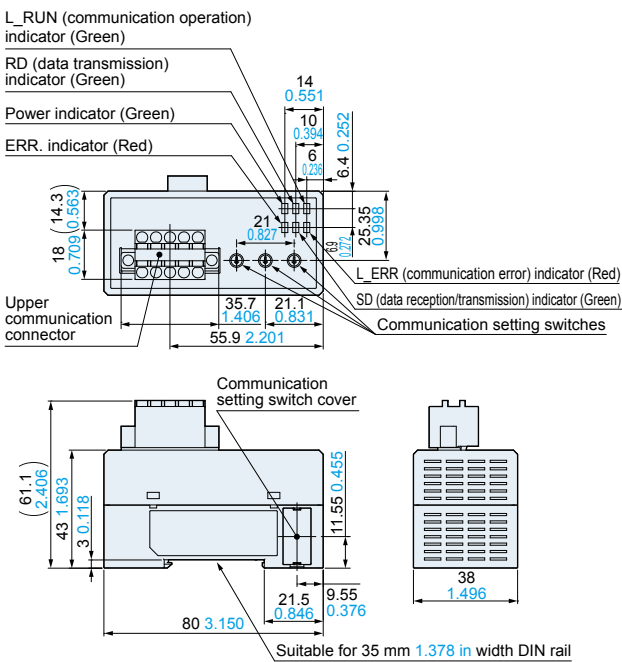

MS-DIN-E End plate

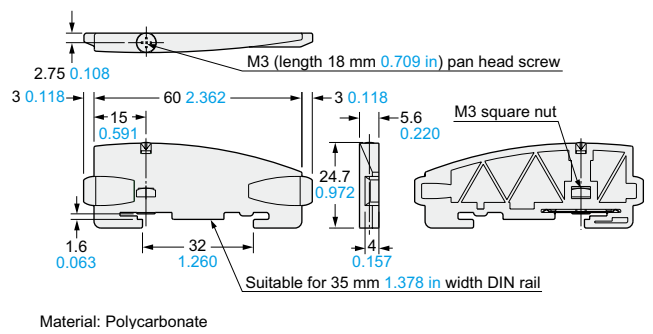

FIBER SENSORS

LASER SENSORS

PHOTO-ELECTRIC SENSORS
MICRO PHOTO-ELECTRIC SENSORS

AREA SENSORS

SAFETY LIGHT CURTAINS / SAFETY COMPONENTS

PRESSURE / FLOW SENSORS

INDUCTIVE PROXIMITY SENSORS

PARTICULAR USE SENSORS

SENSOR OPTIONS

WIRE-SAVING UNITS
WIRE-SAVING SYSTEMS

MEASURE-NEXT SENSORS

STATIC CONTROL DEVICES

LASER MARKERS

PLC

HUMAN MACHINE INTERFACES

ENERGY MANAGEMENT SOLUTIONS

FA COMPONENTS

MACHINE VISION SYSTEMS

UV CURING SYSTEMS

Selection Guide
Laser Displacement
Magnetic Displacement
Contact Displacement

Collimated Beam Sensors
Metal-sheet Double-feed Detection

Digital Panel Controller
Other Products

HG-S

MEMO

