

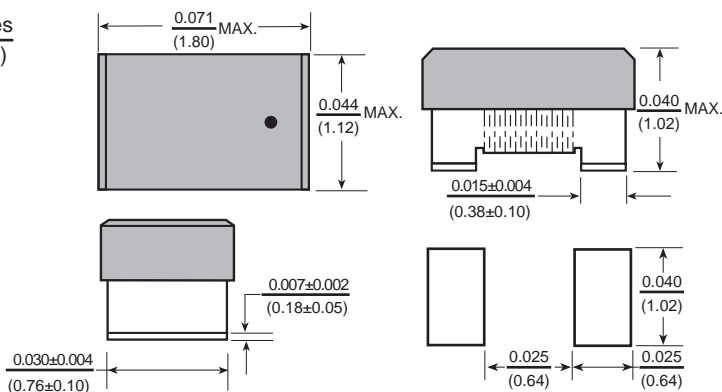

Ceramic Core Chip Inductors CC03



Dimensions: $\frac{\text{Inches}}{\text{(mm)}}$



Allied Part Number	Inductance (nh)	Tolerance (%)	Q Min.	Test Freq. (MHz)	SRF Min. (MHz)	DCR Max. (Ω)	Rated Current (mA)
CC03-1N6K-RC	1.6	10	24	250	12500	0.030	700
CC03-1N8K-RC	1.8	10	16	250	12500	0.045	700
CC03-2N2K-RC	2.2	10	13	250	12500	0.250	100
CC03-3N3K-RC	3.3	10	35	250	5900	0.045	700
CC03-3N6K-RC	3.6	10	22	250	5900	0.063	700
CC03-3N9K-RC	3.9	10	22	250	6900	0.080	700
CC03-4N3K-RC	4.3	10	22	250	5900	0.063	700
CC03-4N7K-RC	4.7	10	20	250	5800	0.116	700
CC03-5N1K-RC	5.1	10	20	250	5700	0.140	700
CC03-5N6K-RC	5.6	10	20	250	5800	0.170	700
CC03-6N3K-RC	6.3	10	20	250	5700	0.140	700
CC03-6N8K-RC	6.8	10	27	250	5800	0.110	700
CC03-7N5K-RC	7.5	10	28	250	4800	0.106	700
CC03-8N2K-RC	8.2	10	28	250	4700	0.109	700
CC03-8N7J-RC	8.7	5	28	250	4600	0.109	700
CC03-9N5J-RC	9.5	5	28	250	5400	0.135	700
CC03-10NJ-RC	10	5	31	250	4800	0.130	700
CC03-11NJ-RC	11	5	33	250	4000	0.086	700
CC03-12NJ-RC	12	5	35	250	4000	0.130	700
CC03-15NJ-RC	15	5	35	250	4000	0.170	700
CC03-16NJ-RC	16	5	34	250	3300	0.104	700
CC03-18NJ-RC	18	5	35	250	3100	0.170	700
CC03-22NJ-RC	22	5	38	250	3000	0.190	700
CC03-24NJ-RC	24	5	37	250	2650	0.135	700
CC03-27NJ-RC	27	5	40	250	2800	0.220	600
CC03-30NJ-RC	30	5	37	250	2250	0.144	600
CC03-33NJ-RC	33	5	40	250	2300	0.220	600
CC03-36NJ-RC	36	5	38	250	2080	0.250	600
CC03-39NJ-RC	39	5	40	250	2200	0.250	600
CC03-43NJ-RC	43	5	39	250	2000	0.280	600
CC03-47NJ-RC	47	5	38	200	2000	0.280	600
CC03-51NJ-RC	51	5	38	200	1900	0.310	600
CC03-56NJ-RC	56	5	38	200	1900	0.310	600
CC03-68NJ-RC	68	5	37	200	1700	0.340	600
CC03-72NJ-RC	72	5	34	150	1700	0.490	400
CC03-82NJ-RC	82	5	34	150	1700	0.540	400
CC03-91NJ-RC	91	5	34	150	1400	0.580	400
CC03-100NJ-RC	100	5	34	150	1400	0.580	400
CC03-110NJ-RC	110	5	32	150	1350	0.610	300
CC03-120NJ-RC	120	5	32	150	1300	0.750	300
CC03-150NJ-RC	150	5	28	150	990	0.920	280
CC03-160NJ-RC	160	5	25	100	990	1.250	240
CC03-180NJ-RC	180	5	25	100	990	1.250	240
CC03-220NJ-RC	220	5	25	100	900	2.100	200
CC03-270NJ-RC	270	5	24	100	900	2.800	170
CC03-330NJ-RC	330	5	25	100	900	3.890	100
CC03-390NJ-RC	390	5	25	100	700	4.350	100
CC03-470NJ-RC	470	5	25	100	500	4.500	100

Available in tighter tolerances.
All specifications subject to change without notice.

Features

- 0603 size suitable for pick and place automation
- Low Profile under 1.02mm
- Ceramic core provide high self resonant frequency.
- High Q values at high frequencies
- Ceramic core also provides excellent thermal and batch consistency

Electrical

Inductance Range: 1.6nH to 470nH
Tolerance: 5% over entire range, except 1.6nH thru 8.2nH they are available in 10%
 Most valued available tighter tolerances
Test Frequency: At specified frequency with Test OSC @ 200mV
Operating Temp: -40°C ~ 125°C
Irms: Based on 15°C temperature rise @ 25° Ambient.

Resistance to Soldering Heat

Test Method: Reflow Solder the device onto PCB
 Peak Temp: 260°C ± 5°C for 10 sec.
 Solder Composition: Sn/Ag3.0/Cu0.5
 Total test time: 6 minutes

Test Equipment

(L/Q): HP4286A / HP4287A /Agilent E4991A
(SRF): HP8753D / Agilent E4991
(RDC): Chen Hwa 502BC
Irms: HP4284A + HP42841A / HP4285A + HP42841A

Physical

Packaging: 4000 pieces per 7 inch reel.
Marking: Single Dot Color Code System