

7-3. SCHEMATIC DIAGRAM – RF Section – • See page 31 for Waveforms. • See page 32 for IC Block Diagrams.

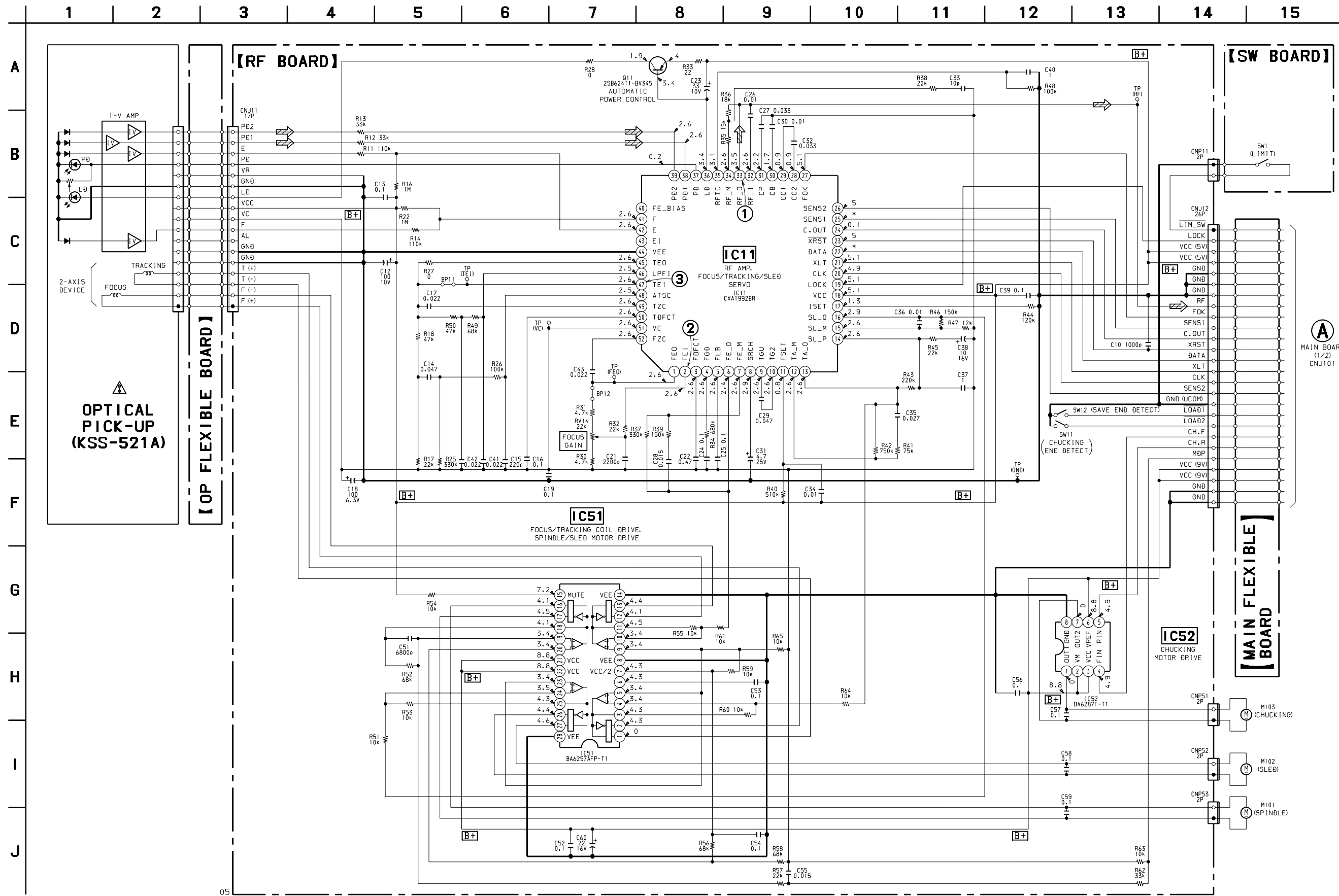

(Page 27)  
MAIN BOARD  
(1/2)  
CNJ101

The components identified by mark  $\Delta$  or dotted line with mark  $\Delta$  are critical for safety. Replace only with part number specified.

Les composants identifiés par une marque  $\Delta$  sont critiques pour la sécurité. Ne les remplacer que par une pièce portant le numéro spécifié.

# CDX-424RF

## SERVICE MANUAL

US Model  
Canadian Model  
E Model



Model Name Using Similar Mechanism	CDX-505RF
CD Drive Mechanism Type	MG-250C-137
Optical Pick-up Name	KSS-521A/J2N

### SPECIFICATIONS

#### CD changer (CDX-424RF)

System	Compact disc digital audio system
Laser Diode Properties	Material: GaAlAs Wavelength: 780 nm Emission Duration: Continuous Laser out-put Power: Less than 44.6 $\mu$ W*
* This output is the value measured at a distance of 200 mm from the objective lens surface on the Optical Pick-up Block.	
Frequency response	10 – 20,000 Hz
Wow and flutter	Below than the measurable limit
Signal-to-noise ratio	94 dB
Output terminals	BUS control output terminal (8 pin) Analog audio output terminal (RCA pin)
Current drain	800 mA (at playback) 800 mA (at disc loading/ejecting)
Operating temperature	-10 °C to +55 °C (14 °F to 131 °F)
Dimensions	Approx. 262 × 90 × 181.5 mm (10 <sup>3</sup> / <sub>8</sub> × 3 <sup>5</sup> / <sub>8</sub> × 7 <sup>1</sup> / <sub>4</sub> in.) (w/h/d)
Mass	Approx. 2.1 kg (4 lb. 10 oz.)

#### Hideaway unit/

#### Wired remote (RM-X64)

Frequency	88.3 MHz/88.5 MHz/ 88.7 MHz/88.9 MHz/ 89.1 MHz/89.3 MHz/ 89.5 MHz/89.7 MHz/ 89.9 MHz (switchable)
Dimensions	Hideaway unit: Approx. 124.8 × 30.0 × 99.8 mm (5 × 1 <sup>3</sup> / <sub>16</sub> × 4 in.) (w/h/d) Wired remote: Approx. 148 × 30 × 15 mm (5 <sup>7</sup> / <sub>8</sub> × 1 <sup>3</sup> / <sub>16</sub> × 1 <sup>9</sup> / <sub>32</sub> in.) (w/h/d)
Mass	Hideaway unit: Approx. 330 g (11.64 oz.) Wired remote: Approx. 120 g (4.2 oz.)

#### Supplied accessories

Disc magazine (1)  
Parts for installation and connections (1 set)

*Design and specifications subject to change without notice.*

## COMPACT DISC CHANGER SYSTEM



# SONY®

7-6. SCHEMATIC DIAGRAM – MAIN Section (1/2) – • See page 31 for Waveforms. • See page 33 for IC Block Diagrams.

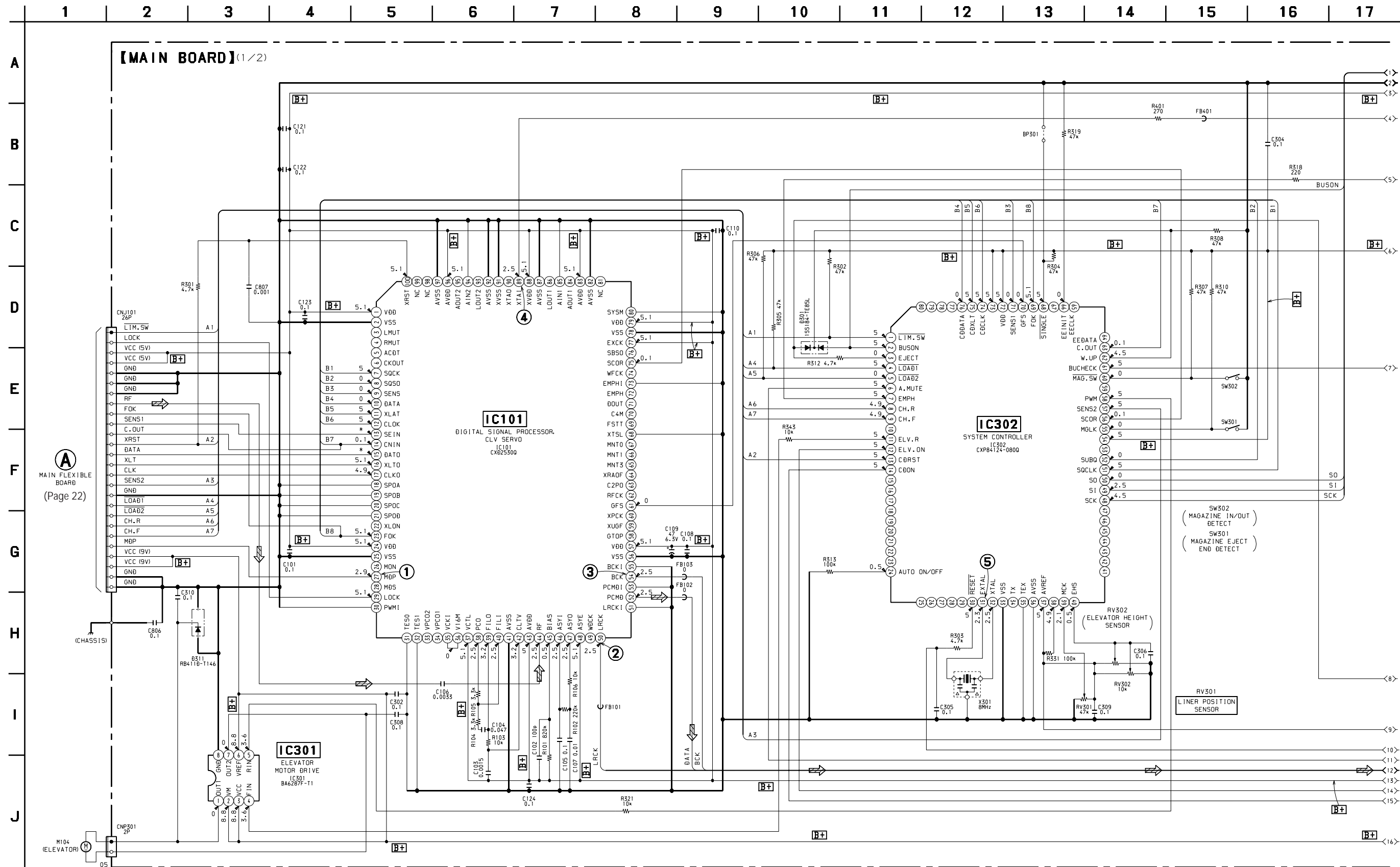

7-7. SCHEMATIC DIAGRAM – MAIN Section (2/2) – • See page 31 for Waveforms. • See page 33 for IC Block Diagrams.

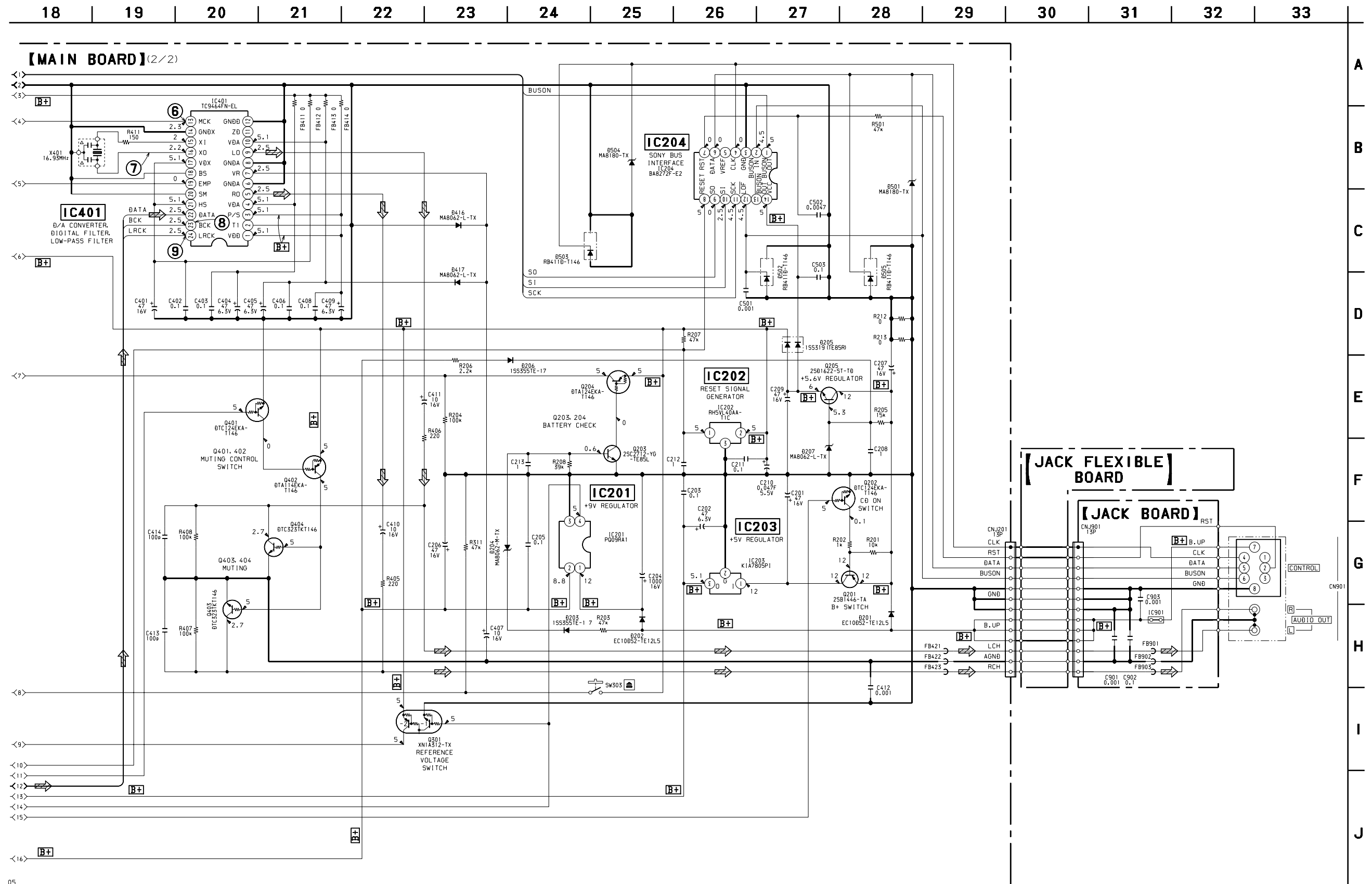

• Waveforms  
– RF Board –

1 IC11 ③ (RF O)  
500 mV/DIV, 500 ns/DIV

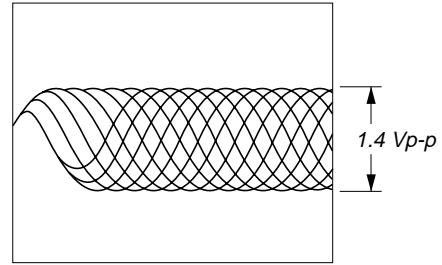

2 IC11 ② (FEI)  
50 mV/DIV, 1 μs/DIV

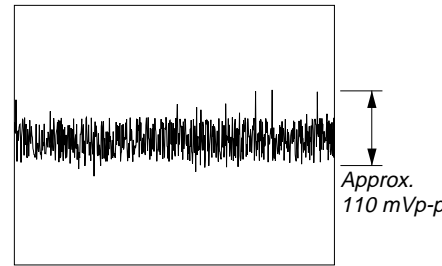

3 IC11 ④ (TEI)  
200 mV/DIV, 500 μs/DIV

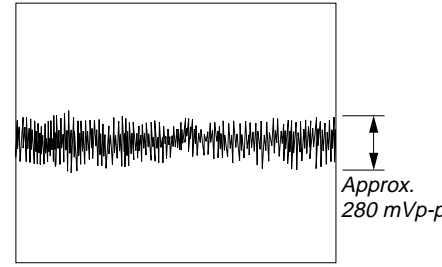

– MAIN Board (1/2) –

1 IC101 ② (MDP)

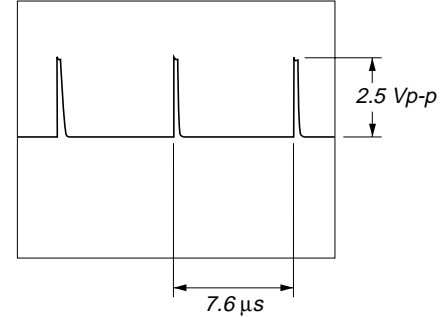

2 IC101 ⑤ (LRCK)

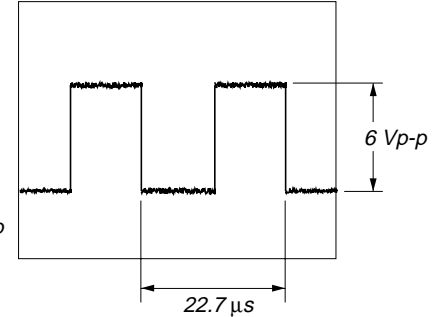

3 IC101 ⑥ (BCK)

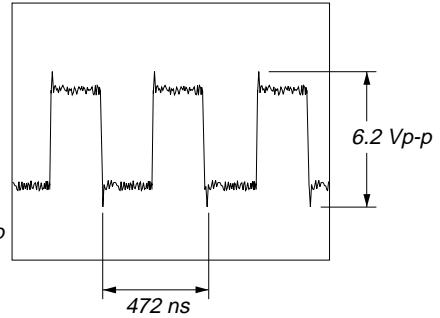

4 IC101 ⑧ (XTAI)

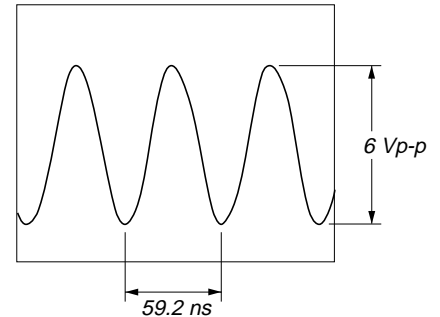

5 IC302 ③ (EXTAL)

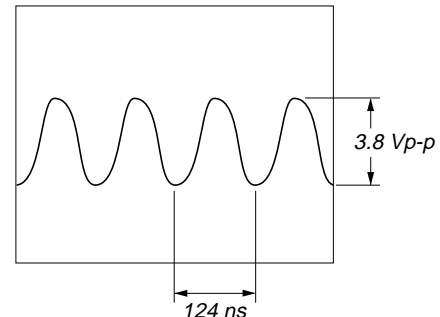

– MAIN Board (2/2) –

6 IC401 ⑬ (MCK)

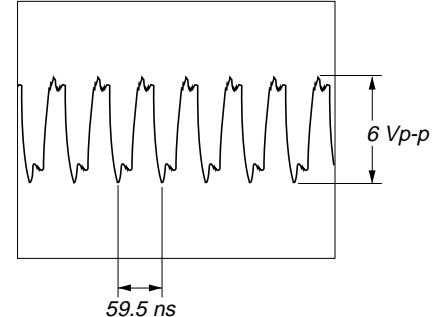

7 IC401 ⑮ (XO)

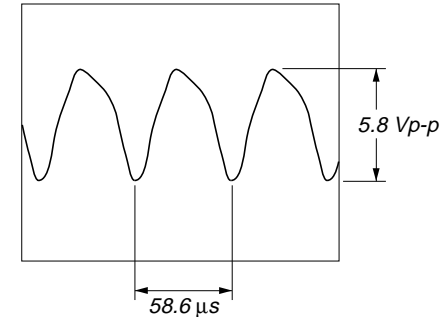

8 IC401 ⑲ (BCK)

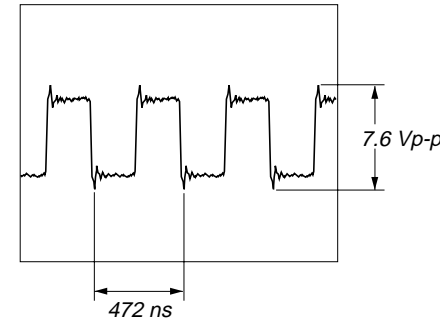

9 IC401 ⑳ (LRCK)

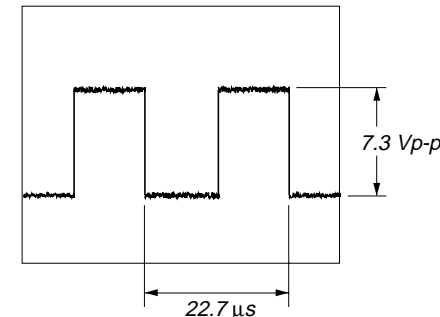

• IC Block Diagrams  
– RF Board –

IC11 CXA1992BR

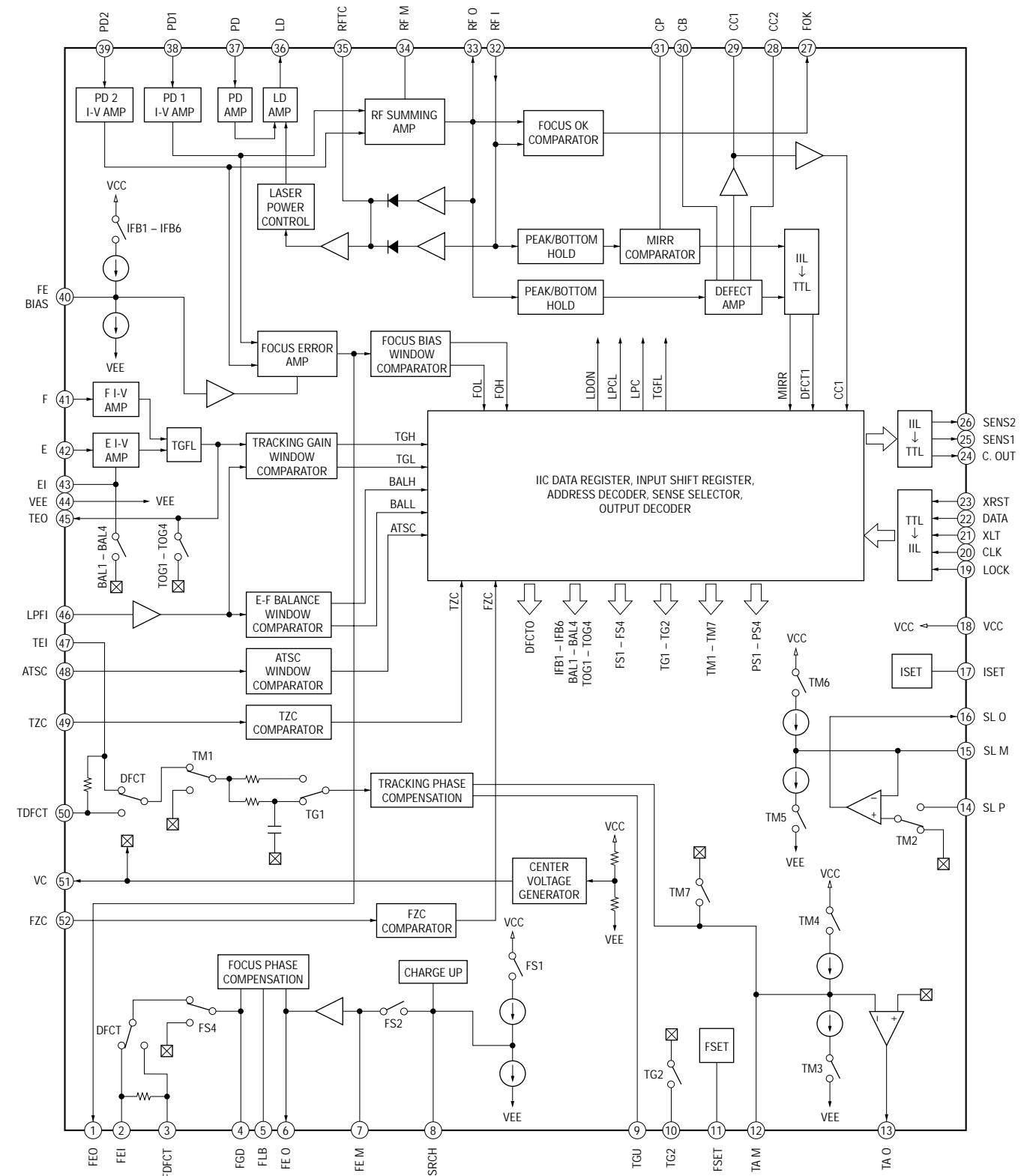

**IC52 BA6287F**

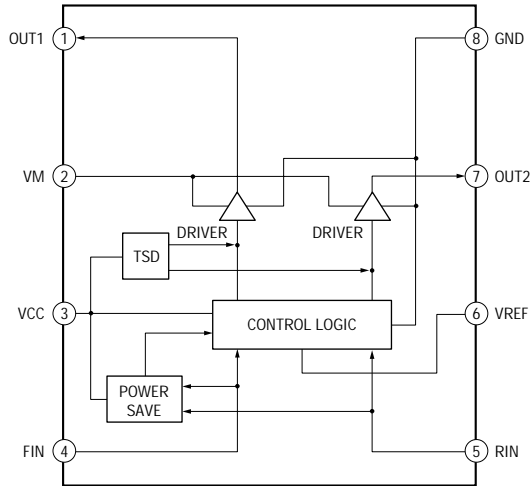

**- MAIN Board -**

**IC101 CXD2530Q**

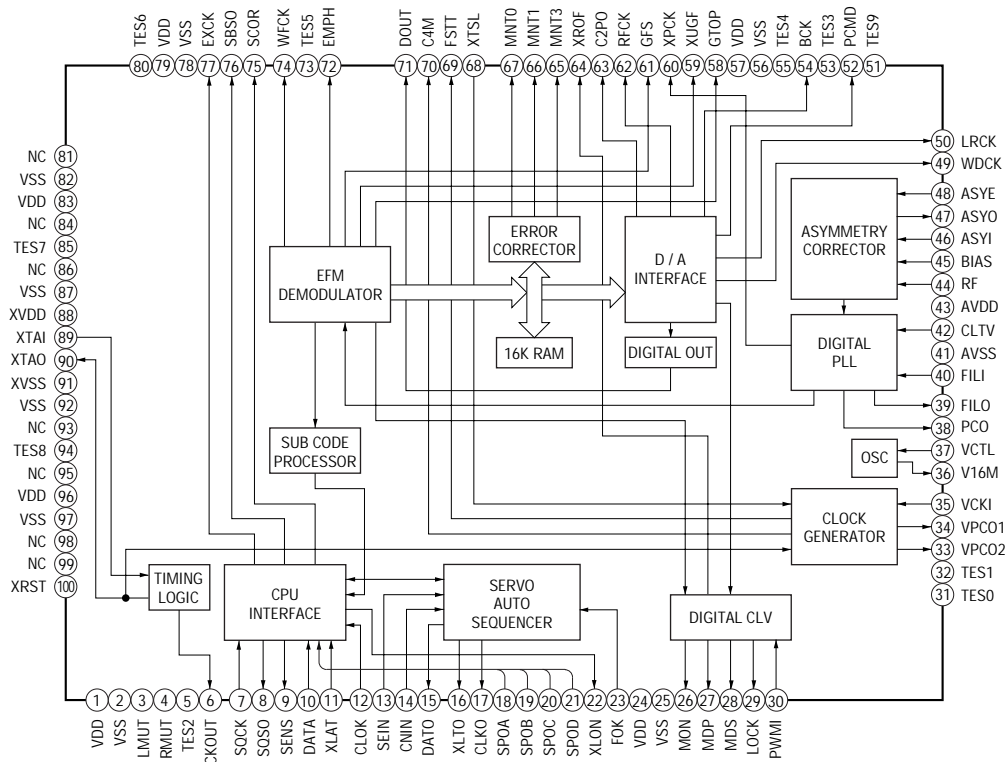

**IC204 BA8272F-E2**

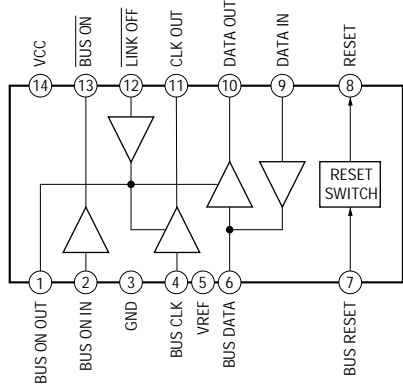

**IC301 BA6287F**

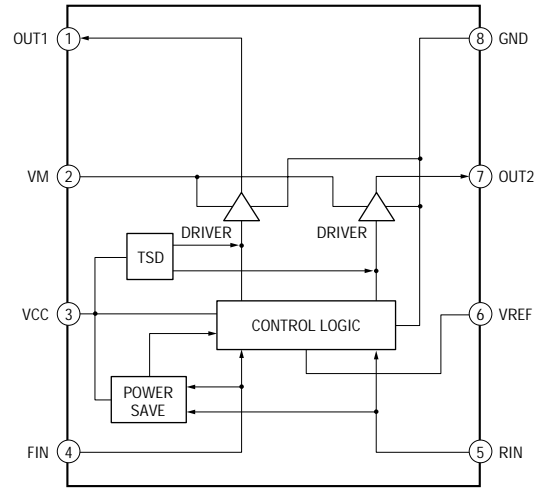

**IC401 TC9464FN-EL**

