

Specifications for PULCOM V Series Units

Sample Timing Charts

Timing Chart (Judgment output mode Y21)

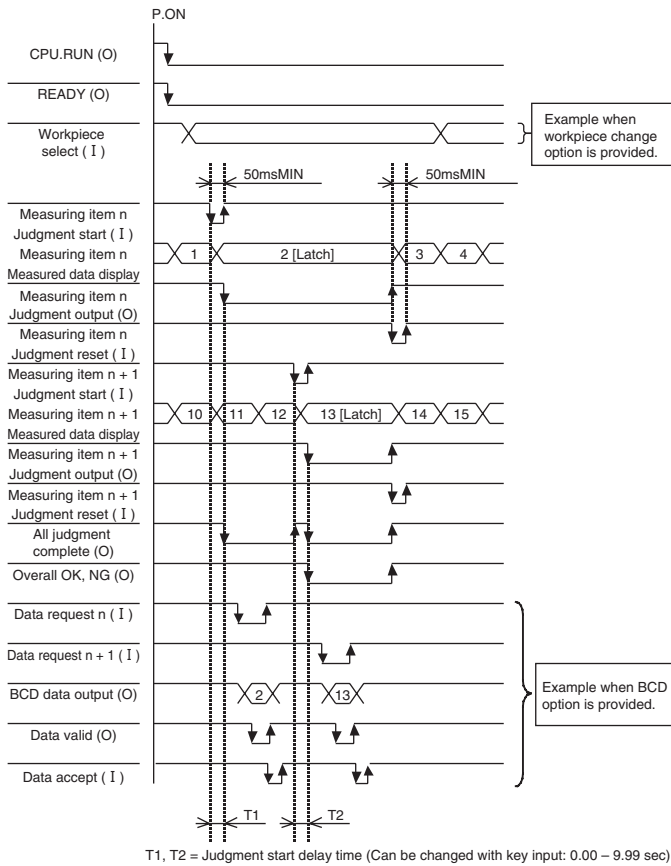

Timing Chart (Judgment output mode Y11)

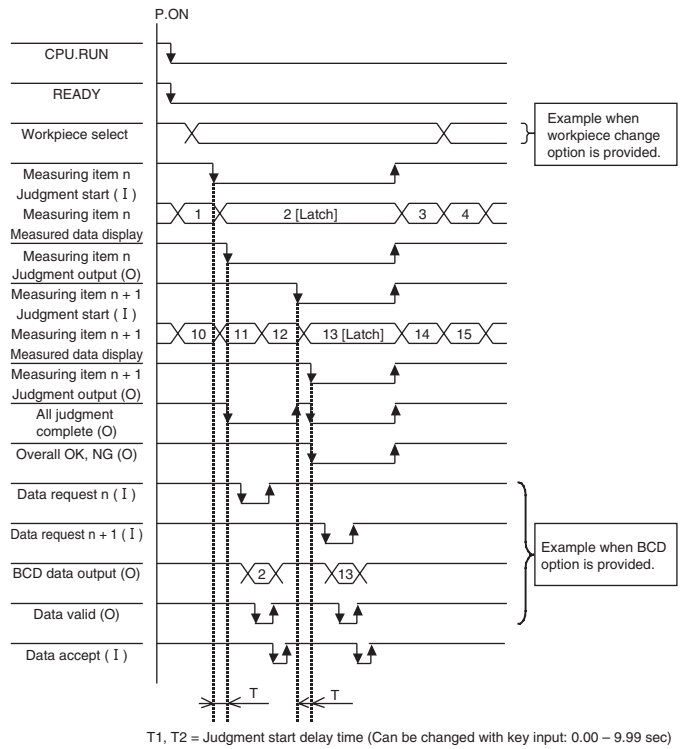

Timing Chart (Judgment output mode Y00)

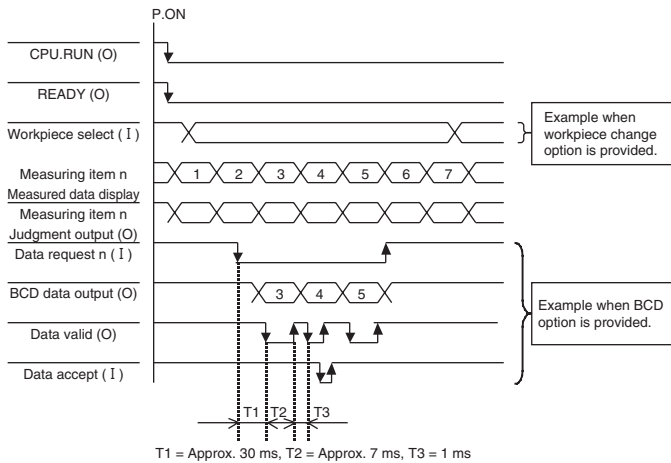

Timing Chart (Judgment output mode Y10)

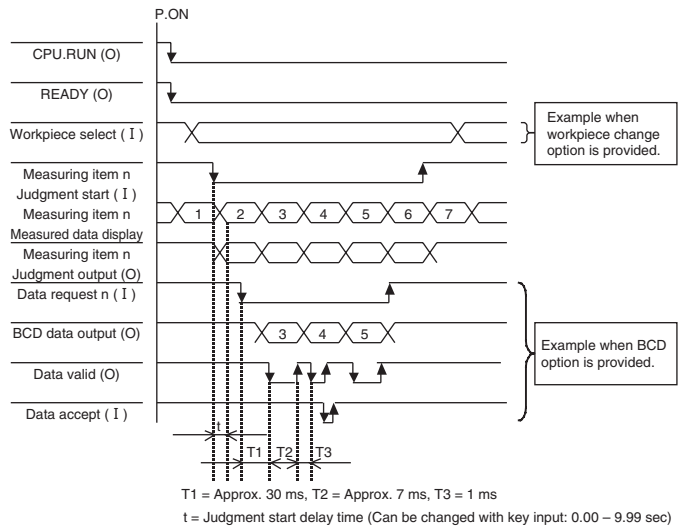

* (O) is output signal, (I) is input signal

Note 1) Regarding measuring item n judgment output:
 (For in-process, SZ1, 2, 3, 4, ...
 (For post-process, ±NG, ±OK, OK, ...)

Note 2) The pulse interval for data accept is 1 ms or greater.

Examples of Input/Output Signal Interference

	Examples of Control Signal Output Interference	Examples of Control Signal Input Interference	
Open Collector Specifications			
Open Emitter Specifications			
Open Drain	Current Sink Connection		
	Current Source Connection		