



S-19100xxxA Series

FOR AUTOMOTIVE 125°C OPERATION VOLTAGE DETECTOR BUILT-IN DELAY CIRCUIT (EXTERNAL DELAY TIME SETTING)

www.sii-ic.com

© SII Semiconductor Corporation, 2012-2015

Rev.1.2_01

The S-19100xxxA Series, developed by using CMOS technology, is a voltage detector IC for automotive 125°C operation. The detection voltage is fixed internally with an accuracy of $\pm 3.0\%$ ($-V_{DET} = 2.4\text{ V}$). It operates with current consumption of 270 nA typ.

The release signal can be delayed by setting a capacitor externally, and the delay time accuracy at $T_a = +25^\circ\text{C}$ is $\pm 15\%$. The operation temperature range is $T_a = -40^\circ\text{C}$ to $+125^\circ\text{C}$. Two output forms Nch open-drain and CMOS output are available.

Compared with conventional CMOS voltage detectors, the S-19100xxxA Series has super-low current consumption and small packages.

Caution This product can be used in vehicle equipment and in-vehicle equipment. Before using the product in the purpose, contact to SII Semiconductor Corporation is indispensable.

■ Features

- Detection voltage: 1.2 V to 4.6 V (0.1 V step)
- Detection voltage accuracy: $\pm 3.0\%$ ($2.4\text{ V} \leq -V_{DET} \leq 4.6\text{ V}$, $T_a = -40^\circ\text{C}$ to $+125^\circ\text{C}$)
 $\pm(2.5\% + 12\text{ mV})$ ($1.2\text{ V} \leq -V_{DET} < 2.4\text{ V}$, $T_a = -40^\circ\text{C}$ to $+125^\circ\text{C}$)
- Current consumption: 270 nA typ. ($1.2\text{ V} \leq -V_{DET} < 2.3\text{ V}$)
- Operation voltage range: 0.6 V to 10.0 V (CMOS output product)
- Hysteresis width*1: $5\% \pm 2\%$ ($T_a = -40^\circ\text{C}$ to $+125^\circ\text{C}$)
- Delay time accuracy: $\pm 15\%$ ($C_D = 4.7\text{ nF}$, $T_a = +25^\circ\text{C}$)
- Output form: Nch open-drain output (active "L")
CMOS output (active "L")
- Operation temperature range: $T_a = -40^\circ\text{C}$ to $+125^\circ\text{C}$
- Lead-free (Sn 100%), halogen-free
- AEC-Q100 qualified*2

*1. The product without hysteresis width is also available.

*2. Contact our sales office for details.

■ Applications

- For automotive use (engine, transmission, suspension, ABS, related-devices for EV / HEV / PHEV, etc.)

■ Packages

- SOT-23-5
- SC-82AB

■ **Block Diagrams**

1. Nch open-drain output product

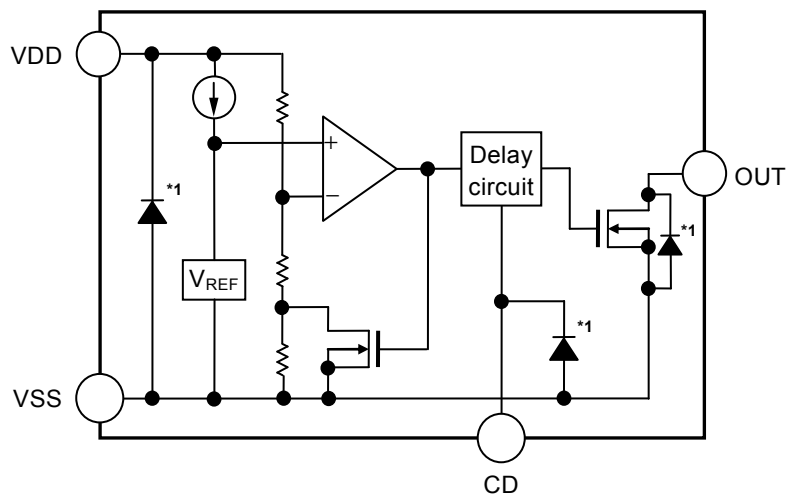

*1. Parasitic diode

Figure 1

2. CMOS output product

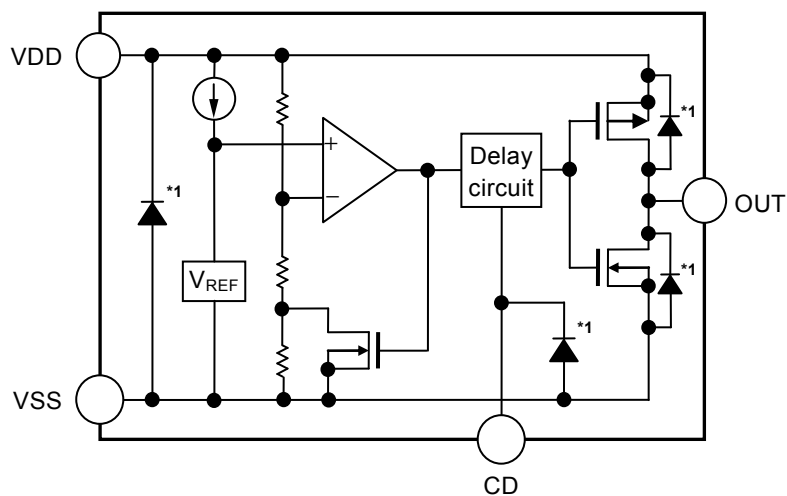

*1. Parasitic diode

Figure 2

■ **AEC-Q100 Qualified**

This IC supports AEC-Q100 for operation temperature grade 1.
 Contact our sales office for details of AEC-Q100 reliability specification.

■ **Product Name Structure**

Users can select the output form, the detection voltage value and the package type for the S-19100xxxA Series. Refer to "1. Product name" regarding the contents of product name, "2. Packages" regarding the package drawings and "3. Product name list" regarding details of product name.

1. **Product name**

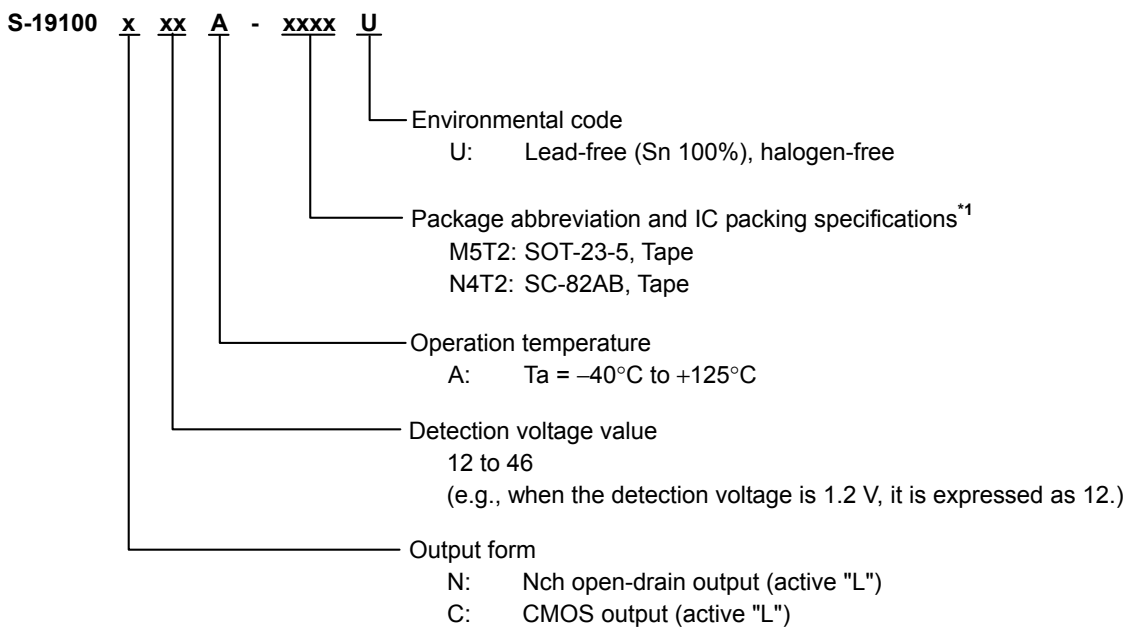

*1. Refer to the tape drawing.

2. **Packages**

Table 1 Package Drawing Codes

| Package Name | Dimension | Tape | Reel |
|--------------|--------------|------------------------------|--------------|
| SOT-23-5 | MP005-A-P-SD | MP005-A-C-SD | MP005-A-R-SD |
| SC-82AB | NP004-A-P-SD | NP004-A-C-SD NP004-A-C-S1 | NP004-A-R-SD |

3. Product name list

3.1 Nch open-drain output product

Table 2

| Detection Voltage | SOT-23-5 | SC-82AB |
|------------------------|-------------------|-------------------|
| 1.2 V ± (2.5% + 12 mV) | S-19100N12A-M5T2U | S-19100N12A-N4T2U |
| 1.3 V ± (2.5% + 12 mV) | S-19100N13A-M5T2U | S-19100N13A-N4T2U |
| 1.4 V ± (2.5% + 12 mV) | S-19100N14A-M5T2U | S-19100N14A-N4T2U |
| 1.5 V ± (2.5% + 12 mV) | S-19100N15A-M5T2U | S-19100N15A-N4T2U |
| 1.6 V ± (2.5% + 12 mV) | S-19100N16A-M5T2U | S-19100N16A-N4T2U |
| 1.7 V ± (2.5% + 12 mV) | S-19100N17A-M5T2U | S-19100N17A-N4T2U |
| 1.8 V ± (2.5% + 12 mV) | S-19100N18A-M5T2U | S-19100N18A-N4T2U |
| 1.9 V ± (2.5% + 12 mV) | S-19100N19A-M5T2U | S-19100N19A-N4T2U |
| 2.0 V ± (2.5% + 12 mV) | S-19100N20A-M5T2U | S-19100N20A-N4T2U |
| 2.1 V ± (2.5% + 12 mV) | S-19100N21A-M5T2U | S-19100N21A-N4T2U |
| 2.2 V ± (2.5% + 12 mV) | S-19100N22A-M5T2U | S-19100N22A-N4T2U |
| 2.3 V ± (2.5% + 12 mV) | S-19100N23A-M5T2U | S-19100N23A-N4T2U |
| 2.4 V ± 3.0% | S-19100N24A-M5T2U | S-19100N24A-N4T2U |
| 2.5 V ± 3.0% | S-19100N25A-M5T2U | S-19100N25A-N4T2U |
| 2.6 V ± 3.0% | S-19100N26A-M5T2U | S-19100N26A-N4T2U |
| 2.7 V ± 3.0% | S-19100N27A-M5T2U | S-19100N27A-N4T2U |
| 2.8 V ± 3.0% | S-19100N28A-M5T2U | S-19100N28A-N4T2U |
| 2.9 V ± 3.0% | S-19100N29A-M5T2U | S-19100N29A-N4T2U |
| 3.0 V ± 3.0% | S-19100N30A-M5T2U | S-19100N30A-N4T2U |
| 3.1 V ± 3.0% | S-19100N31A-M5T2U | S-19100N31A-N4T2U |
| 3.2 V ± 3.0% | S-19100N32A-M5T2U | S-19100N32A-N4T2U |
| 3.3 V ± 3.0% | S-19100N33A-M5T2U | S-19100N33A-N4T2U |
| 3.4 V ± 3.0% | S-19100N34A-M5T2U | S-19100N34A-N4T2U |
| 3.5 V ± 3.0% | S-19100N35A-M5T2U | S-19100N35A-N4T2U |
| 3.6 V ± 3.0% | S-19100N36A-M5T2U | S-19100N36A-N4T2U |
| 3.7 V ± 3.0% | S-19100N37A-M5T2U | S-19100N37A-N4T2U |
| 3.8 V ± 3.0% | S-19100N38A-M5T2U | S-19100N38A-N4T2U |
| 3.9 V ± 3.0% | S-19100N39A-M5T2U | S-19100N39A-N4T2U |
| 4.0 V ± 3.0% | S-19100N40A-M5T2U | S-19100N40A-N4T2U |
| 4.1 V ± 3.0% | S-19100N41A-M5T2U | S-19100N41A-N4T2U |
| 4.2 V ± 3.0% | S-19100N42A-M5T2U | S-19100N42A-N4T2U |
| 4.3 V ± 3.0% | S-19100N43A-M5T2U | S-19100N43A-N4T2U |
| 4.4 V ± 3.0% | S-19100N44A-M5T2U | S-19100N44A-N4T2U |
| 4.5 V ± 3.0% | S-19100N45A-M5T2U | S-19100N45A-N4T2U |
| 4.6 V ± 3.0% | S-19100N46A-M5T2U | S-19100N46A-N4T2U |

3.2 CMOS output product

Table 3

| Detection Voltage | SOT-23-5 | SC-82AB |
|------------------------|-------------------|-------------------|
| 1.2 V ± (2.5% + 12 mV) | S-19100C12A-M5T2U | S-19100C12A-N4T2U |
| 1.3 V ± (2.5% + 12 mV) | S-19100C13A-M5T2U | S-19100C13A-N4T2U |
| 1.4 V ± (2.5% + 12 mV) | S-19100C14A-M5T2U | S-19100C14A-N4T2U |
| 1.5 V ± (2.5% + 12 mV) | S-19100C15A-M5T2U | S-19100C15A-N4T2U |
| 1.6 V ± (2.5% + 12 mV) | S-19100C16A-M5T2U | S-19100C16A-N4T2U |
| 1.7 V ± (2.5% + 12 mV) | S-19100C17A-M5T2U | S-19100C17A-N4T2U |
| 1.8 V ± (2.5% + 12 mV) | S-19100C18A-M5T2U | S-19100C18A-N4T2U |
| 1.9 V ± (2.5% + 12 mV) | S-19100C19A-M5T2U | S-19100C19A-N4T2U |
| 2.0 V ± (2.5% + 12 mV) | S-19100C20A-M5T2U | S-19100C20A-N4T2U |
| 2.1 V ± (2.5% + 12 mV) | S-19100C21A-M5T2U | S-19100C21A-N4T2U |
| 2.2 V ± (2.5% + 12 mV) | S-19100C22A-M5T2U | S-19100C22A-N4T2U |
| 2.3 V ± (2.5% + 12 mV) | S-19100C23A-M5T2U | S-19100C23A-N4T2U |
| 2.4 V ± 3.0% | S-19100C24A-M5T2U | S-19100C24A-N4T2U |
| 2.5 V ± 3.0% | S-19100C25A-M5T2U | S-19100C25A-N4T2U |
| 2.6 V ± 3.0% | S-19100C26A-M5T2U | S-19100C26A-N4T2U |
| 2.7 V ± 3.0% | S-19100C27A-M5T2U | S-19100C27A-N4T2U |
| 2.8 V ± 3.0% | S-19100C28A-M5T2U | S-19100C28A-N4T2U |
| 2.9 V ± 3.0% | S-19100C29A-M5T2U | S-19100C29A-N4T2U |
| 3.0 V ± 3.0% | S-19100C30A-M5T2U | S-19100C30A-N4T2U |
| 3.1 V ± 3.0% | S-19100C31A-M5T2U | S-19100C31A-N4T2U |
| 3.2 V ± 3.0% | S-19100C32A-M5T2U | S-19100C32A-N4T2U |
| 3.3 V ± 3.0% | S-19100C33A-M5T2U | S-19100C33A-N4T2U |
| 3.4 V ± 3.0% | S-19100C34A-M5T2U | S-19100C34A-N4T2U |
| 3.5 V ± 3.0% | S-19100C35A-M5T2U | S-19100C35A-N4T2U |
| 3.6 V ± 3.0% | S-19100C36A-M5T2U | S-19100C36A-N4T2U |
| 3.7 V ± 3.0% | S-19100C37A-M5T2U | S-19100C37A-N4T2U |
| 3.8 V ± 3.0% | S-19100C38A-M5T2U | S-19100C38A-N4T2U |
| 3.9 V ± 3.0% | S-19100C39A-M5T2U | S-19100C39A-N4T2U |
| 4.0 V ± 3.0% | S-19100C40A-M5T2U | S-19100C40A-N4T2U |
| 4.1 V ± 3.0% | S-19100C41A-M5T2U | S-19100C41A-N4T2U |
| 4.2 V ± 3.0% | S-19100C42A-M5T2U | S-19100C42A-N4T2U |
| 4.3 V ± 3.0% | S-19100C43A-M5T2U | S-19100C43A-N4T2U |
| 4.4 V ± 3.0% | S-19100C44A-M5T2U | S-19100C44A-N4T2U |
| 4.5 V ± 3.0% | S-19100C45A-M5T2U | S-19100C45A-N4T2U |
| 4.6 V ± 3.0% | S-19100C46A-M5T2U | S-19100C46A-N4T2U |

■ Pin Configurations

1. SOT-23-5

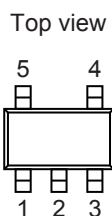

Figure 3

Table 4

| Pin No. | Symbol | Description |
|---------|--------|------------------------------------|
| 1 | OUT | Voltage detection output pin |
| 2 | VDD | Input voltage pin |
| 3 | VSS | GND pin |
| 4 | NC*1 | No connection |
| 5 | CD | Connection pin for delay capacitor |

*1. The NC pin is electrically open.
 The NC pin can be connected to the VDD pin or the VSS pin.

2. SC-82AB

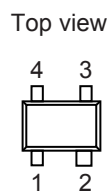

Figure 4

Table 5

| Pin No. | Symbol | Description |
|---------|--------|------------------------------------|
| 1 | VSS | GND pin |
| 2 | VDD | Input voltage pin |
| 3 | CD | Connection pin for delay capacitor |
| 4 | OUT | Voltage detection output pin |

■ Absolute Maximum Ratings

Table 6

(Ta = -40°C to +125°C unless otherwise specified)

| Item | Symbol | Absolute Maximum Rating | Unit |
|-------------------------------|-------------------|----------------------------------|----------------------------------|
| Power supply voltage | $V_{DD} - V_{SS}$ | 12 | V |
| CD pin input voltage | V_{CD} | $V_{SS} - 0.3$ to $V_{DD} + 0.3$ | V |
| Output voltage | V_{OUT} | Nch open-drain output product | $V_{SS} - 0.3$ to 12.0 |
| | | CMOS output product | $V_{SS} - 0.3$ to $V_{DD} + 0.3$ |
| Output current | I_{OUT} | 50 | mA |
| Operation ambient temperature | T_{opr} | -40 to +125 | °C |
| Storage temperature | T_{stg} | -40 to +150 | °C |

Caution The absolute maximum ratings are rated values exceeding which the product could suffer physical damage. These values must therefore not be exceeded under any conditions.

■ Thermal Resistance Value

Table 7

| Item | Symbol | Condition | Min. | Typ. | Max. | Unit | |
|--|---------------|-----------|---------|------|------|------|------|
| Junction-to-ambient thermal resistance*1 | θ_{ja} | SOT-23-5 | Board 1 | - | 192 | - | °C/W |
| | | | Board 2 | - | 160 | - | °C/W |
| | | SC-82AB | Board 1 | - | 236 | - | °C/W |
| | | | Board 2 | - | 204 | - | °C/W |

*1. Test environment: compliance with JEDEC STANDARD JESD51-2A

Remark Refer to "■ Thermal Characteristics" for details of power dissipation and test board.

■ **Electrical Characteristics**

1. **Nch open-drain output product**

Table 8

(Ta = -40°C to +125°C unless otherwise specified)

| Item | Symbol | Condition | Min. | Typ. | Max. | Unit | Test Circuit | |
|---------------------|-------------------|---|---|-----------------------------|--|------|--------------|---|
| Detection voltage*1 | -V _{DET} | 1.2 V ≤ -V _{DET} < 2.4 V | -V _{DET(S)} × 0.975 - 0.012 | -V _{DET(S)} | -V _{DET(S)} × 1.025 + 0.012 | V | 1 | |
| | | 2.4 V ≤ -V _{DET} ≤ 4.6 V | -V _{DET(S)} × 0.97 | -V _{DET(S)} | -V _{DET(S)} × 1.03 | V | 1 | |
| Hysteresis width | V _{HYS} | - | -V _{DET} × 0.03 | -V _{DET} × 0.05 | -V _{DET} × 0.07 | V | 1 | |
| Current consumption | I _{SS} | V _{DD} = +V _{DET} + 0.6 V | 1.2 V ≤ -V _{DET} < 2.3 V | - | 0.27 | 1.80 | μA | 2 |
| | | | 2.3 V ≤ -V _{DET} < 3.6 V | - | 0.42 | 2.20 | μA | 2 |
| | | | 3.6 V ≤ -V _{DET} ≤ 4.6 V | - | 0.39 | 2.20 | μA | 2 |
| Operation voltage | V _{DD} | - | 0.8 | - | 10.0 | V | 1 | |
| Output current | I _{OUT} | Output transistor Nch V _{DS} *2 = 0.5 V | V _{DD} = 0.7 V S-19100N12 to 14 | 0.14 | 0.40 | - | mA | 3 |
| | | | V _{DD} = 1.2 V S-19100N15 to 46 | 0.68 | 1.33 | - | mA | 3 |
| | | | V _{DD} = 2.4 V S-19100N27 to 46 | 1.12 | 2.39 | - | mA | 3 |
| Leakage current | I _{LEAK} | Output transistor Nch V _{DD} = 10.0 V, V _{OUT} = 10.0 V | - | - | 2.40 | μA | 3 | |
| Delay time | t _d | C _D = 4.7 nF | 10.0 | 26.0 | 57.0 | ms | 4 | |

*1. -V_{DET}: Actual detection voltage value, -V_{DET(S)}: Set detection voltage value (The center value of the detection voltage range in **Table 2**.)

*2. V_{DS}: Drain-to-source voltage of the output transistor

2. CMOS output product

Table 9

(Ta = -40°C to +125°C unless otherwise specified)

| Item | Symbol | Condition | Min. | Typ. | Max. | Unit | Test Circuit | |
|----------------------|-------------------|---|---|-----------------------------|--|------|--------------|---|
| Detection voltage**1 | -V _{DET} | 1.2 V ≤ -V _{DET} < 2.4 V | -V _{DET(S)} × 0.975 - 0.012 | -V _{DET(S)} | -V _{DET(S)} × 1.025 + 0.012 | V | 1 | |
| | | 2.4 V ≤ -V _{DET} ≤ 4.6 V | -V _{DET(S)} × 0.97 | -V _{DET(S)} | -V _{DET(S)} × 1.03 | V | 1 | |
| Hysteresis width | V _{HYS} | - | -V _{DET} × 0.03 | -V _{DET} × 0.05 | -V _{DET} × 0.07 | V | 1 | |
| Current consumption | I _{SS} | V _{DD} = +V _{DET} + 0.6 V | 1.2 V ≤ -V _{DET} < 2.3 V | - | 0.27 | 1.80 | μA | 2 |
| | | | 2.3 V ≤ -V _{DET} < 3.6 V | - | 0.42 | 2.20 | μA | 2 |
| | | | 3.6 V ≤ -V _{DET} ≤ 4.6 V | - | 0.39 | 2.20 | μA | 2 |
| Operation voltage | V _{DD} | - | 0.6 | - | 10.0 | V | 1 | |
| Output current | I _{OUT} | Output transistor Nch V _{DS} **2 = 0.5 V | V _{DD} = 0.7 V S-19100C12 to 14 | 0.14 | 0.40 | - | mA | 3 |
| | | | V _{DD} = 1.2 V S-19100C15 to 46 | 0.68 | 1.33 | - | mA | 3 |
| | | | V _{DD} = 2.4 V S-19100C27 to 46 | 1.12 | 2.39 | - | mA | 3 |
| | | Output transistor Pch V _{DS} **2 = 0.5 V | V _{DD} = 4.8 V S-19100C12 to 39 | 1.42 | 2.60 | - | mA | 5 |
| | | | V _{DD} = 6.0 V S-19100C40 to 46 | 1.58 | 2.86 | - | mA | 5 |
| | | | | | | | | |
| Delay time | t _D | C _D = 4.7 nF | 10.0 | 26.0 | 57.0 | ms | 4 | |

*1. -V_{DET}: Actual detection voltage value, -V_{DET(S)}: Set detection voltage value (The center value of the detection voltage range in **Table 3**.)

*2. V_{DS}: Drain-to-source voltage of the output transistor

■ Test Circuits

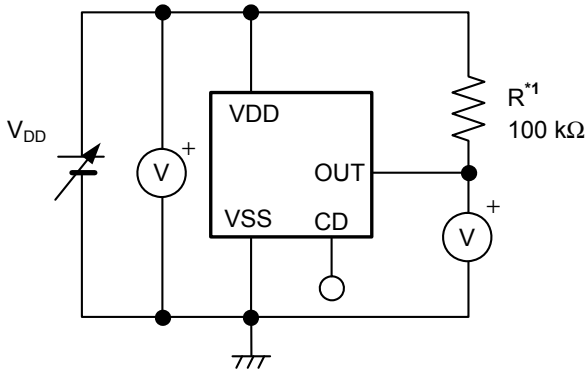

*1. R is unnecessary for CMOS output product.

Figure 5 Test Circuit 1

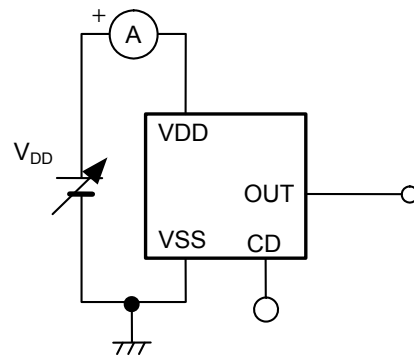

Figure 6 Test Circuit 2

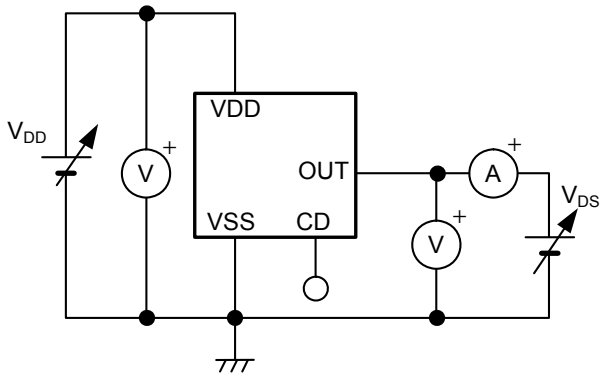
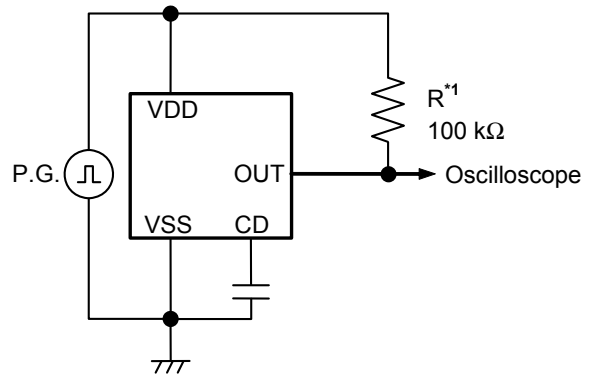

Figure 7 Test Circuit 3



*1. R is unnecessary for CMOS output product.

Figure 8 Test Circuit 4

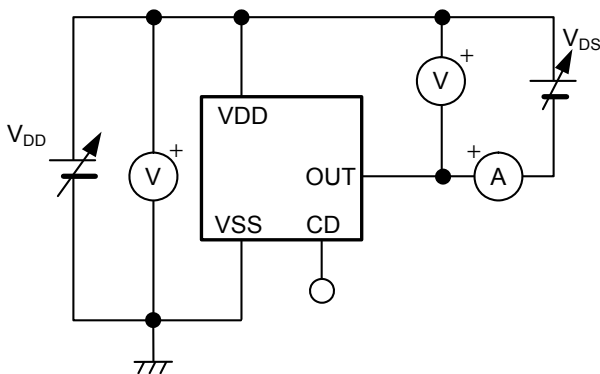

Figure 9 Test Circuit 5

■ Timing Charts

1. Nch open-drain output product

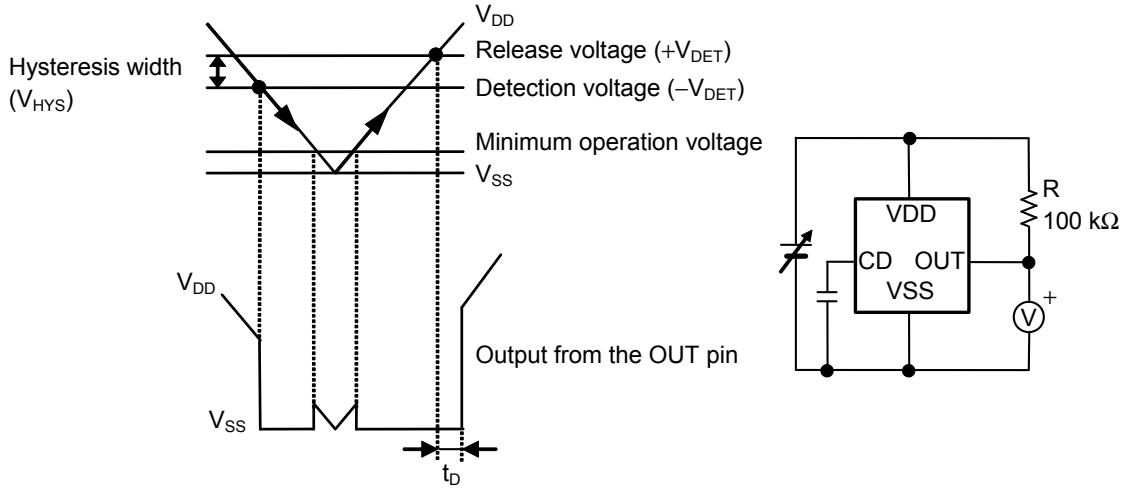
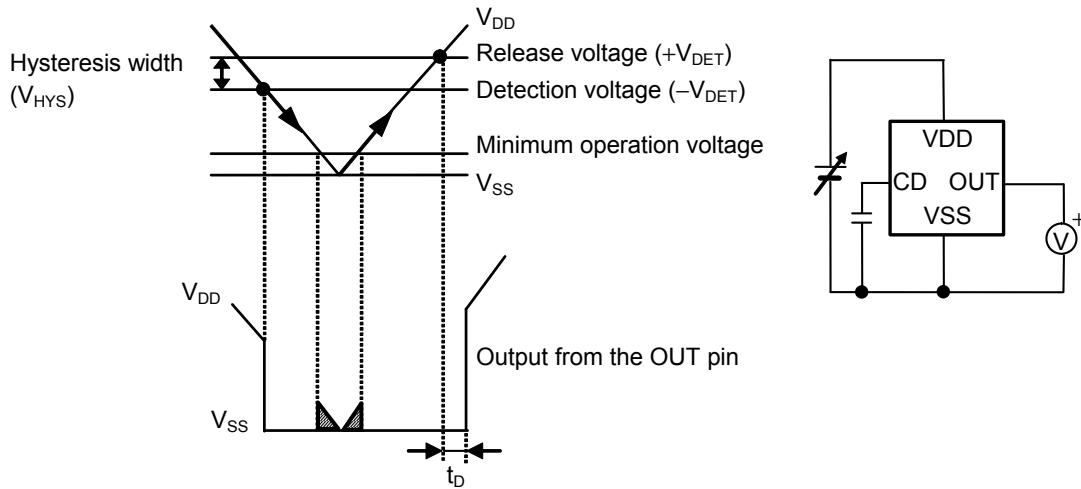

Figure 10

2. CMOS output product



Remark When V_{DD} is the minimum operation voltage or less, the output voltage from the OUT pin is indefinite in the shaded area.

Figure 11

■ **Operation**

1. Basic operation: CMOS output (active "L") product

- (1) When the power supply voltage (V_{DD}) is the release voltage ($+V_{DET}$) or higher, the Nch transistor is turned off and the Pch transistor is turned on to output V_{DD} ("H"). Since the Nch transistor N1 in **Figure 12** is turned off, the input voltage to the comparator is $\frac{(R_B + R_C) \cdot V_{DD}}{R_A + R_B + R_C}$.
- (2) Even if V_{DD} decreases to $+V_{DET}$ or lower, V_{DD} is output when V_{DD} is higher than the detection voltage ($-V_{DET}$). When V_{DD} decreases to $-V_{DET}$ (point A in **Figure 13**) or lower, the Nch transistor is turned on and the Pch transistor is turned off, and then V_{SS} ("L") is output. At this time, the Nch transistor N1 in **Figure 12** is turned on, and the input voltage to the comparator is $\frac{R_B \cdot V_{DD}}{R_A + R_B}$.
- (3) The output is unstable if V_{DD} further decreases to the IC's minimum operation voltage or lower, and the output is V_{DD} when the output is pulled up.
- (4) V_{SS} is output when V_{DD} increases to the minimum operation voltage or higher. Even if V_{DD} exceeds $-V_{DET}$, the output is V_{SS} when V_{DD} is lower than $+V_{DET}$.
- (5) When V_{DD} increases to $+V_{DET}$ (point B in **Figure 13**) or higher, the Nch transistor is turned off and the Pch transistor is turned on, and then V_{DD} is output. At this time, V_{DD} is output from the OUT pin after the elapse of the delay time (t_D).

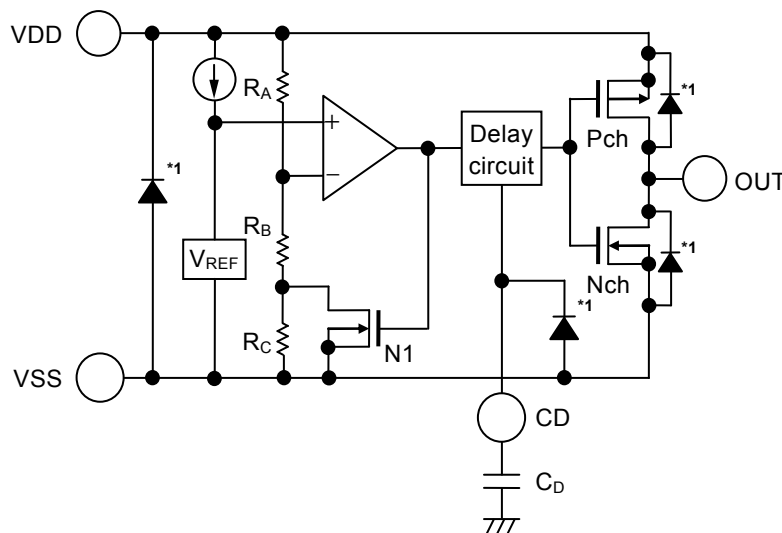

*1. Parasitic diode

Figure 12 Operation 1

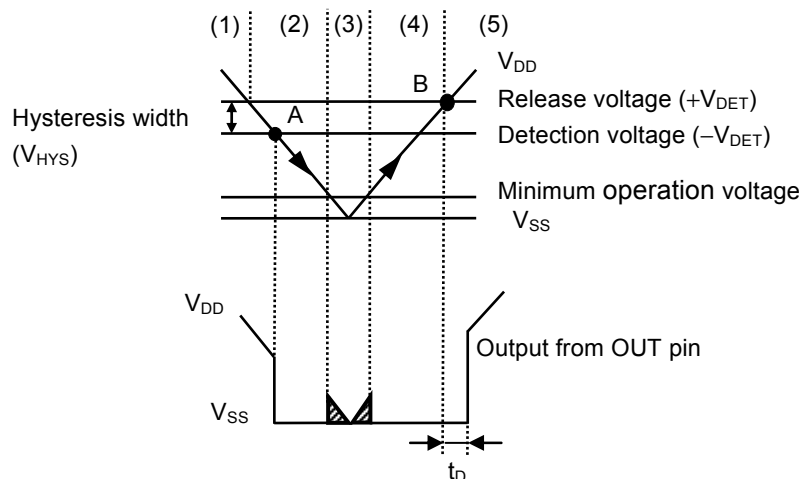

Figure 13 Operation 2

2. Delay circuit

The delay circuit delays the output signal to the OUT pin from the time at which the power supply voltage (V_{DD}) exceeds the release voltage ($+V_{DET}$) when the power supply voltage (V_{DD}) is turned on. The output signal is not delayed when V_{DD} decreases to the detection voltage ($-V_{DET}$) or less (refer to "Figure 13 Operation 2").

The delay time (t_D) is determined by the time constant of the built-in constant current (approx. 100 nA) and the attached delay capacitor (C_D), or the delay time when the CD pin is open (t_{D0}), and calculated from the following equation. When the C_D value is sufficiently large, the t_{D0} value can be ignored.

$$t_D [\text{ms}] = \text{Delay coefficient} \times C_D [\text{nF}] + t_{D0} [\text{ms}]$$

Table 10 Delay Coefficient

| Operation Temperature | Delay Coefficient | | |
|-----------------------|-------------------|------|-------|
| | Min. | Typ. | Max. |
| Ta = +125°C | 1.96 | 3.50 | 5.15 |
| Ta = +105°C | 2.58 | 3.70 | 5.40 |
| Ta = +25°C | 4.70 | 5.47 | 6.24 |
| Ta = -40°C | 5.64 | 8.40 | 12.01 |

Table 11 Delay Time

| Operation Temperature | Delay Time when CD pin is Open (t_{D0}) | | |
|-----------------------|---|---------|---------|
| | Min. | Typ. | Max. |
| Ta = -40°C to +125°C | 0.01 ms | 0.10 ms | 0.80 ms |

- Caution 1.** When the CD pin is open, a double pulse shown in Figure 14 may appear at release. To avoid the double pulse, attach 100 pF or more capacitor to the CD pin. Do not apply voltage to the CD pin from the exterior.

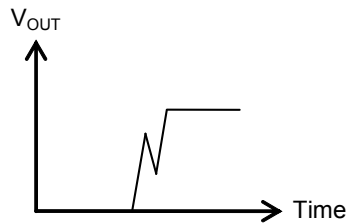
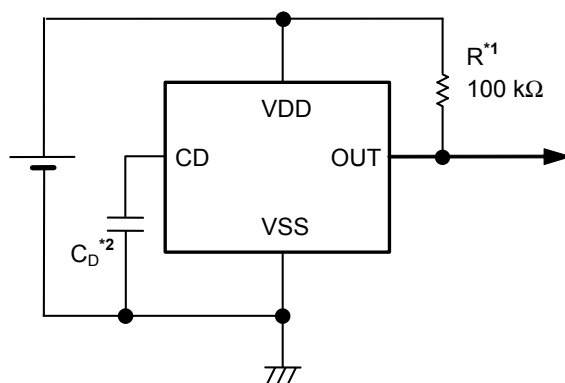

Figure 14

- Mounted board layout should be made in such a way that no current flows into or flows from the CD pin since the impedance of the CD pin is high, otherwise correct delay time cannot be provided.
- There is no limit for the capacitance of C_D as long as the leakage current of the capacitor can be ignored against the built-in constant current value. Leakage current causes deviation in delay time. When the leakage current is larger than the built-in constant current, no release takes place.

■ Standard Circuit



- *1. R is unnecessary for CMOS output products.
- *2. The delay capacitor (C_D) should be connected directly to the CD pin and the VSS pin.

Figure 15

Caution The above connection diagram and constant will not guarantee successful operation. Perform thorough evaluation using the actual application to set the constant.

■ Explanation of Terms

1. Detection voltage ($-V_{DET}$)

The detection voltage is a voltage at which the output in **Figure 18** turns to "L". The detection voltage varies slightly among products of the same specification. The variation of detection voltage between the specified minimum ($-V_{DET}$ min.) and the maximum ($-V_{DET}$ max.) is called the detection voltage range (refer to **Figure 16**).

Example: In the S-19100C20A, the detection voltage is either one in the range of $1.938\text{ V} \leq -V_{DET} \leq 2.062\text{ V}$. This means, at the operation temperature -40°C to $+125^\circ\text{C}$, some S-19100C20A have $-V_{DET} = 1.938\text{ V}$ and some have $-V_{DET} = 2.062\text{ V}$.

2. Release voltage ($+V_{DET}$)

The release voltage is a voltage at which the output in **Figure 18** turns to "H". The release voltage varies slightly among products of the same specification. The variation of release voltages between the specified minimum ($+V_{DET}$ min.) and the maximum ($+V_{DET}$ max.) is called the release voltage range (refer to **Figure 17**). The value is calculated from the actual detection voltage ($-V_{DET}$) of a product and is in the range of $-V_{DET} \times 1.03 \leq +V_{DET} \leq -V_{DET} \times 1.07$.

Example: In the S-19100C20A, the release voltage is either one in the range of $1.997\text{ V} \leq +V_{DET} \leq 2.206\text{ V}$. This means, at the operation temperature -40°C to $+125^\circ\text{C}$, some S-19100C20A have $+V_{DET} = 1.997\text{ V}$ and some have $+V_{DET} = 2.206\text{ V}$.

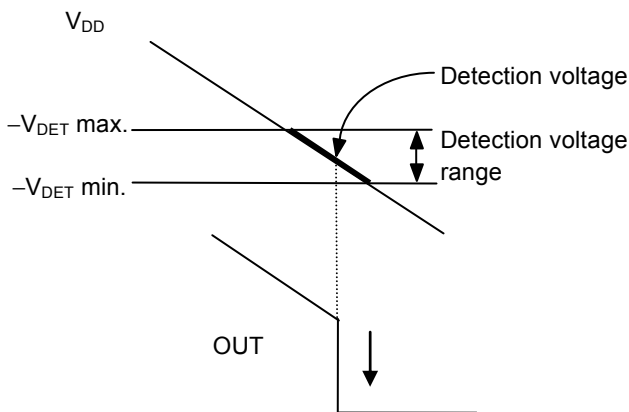

Figure 16 Detection Voltage

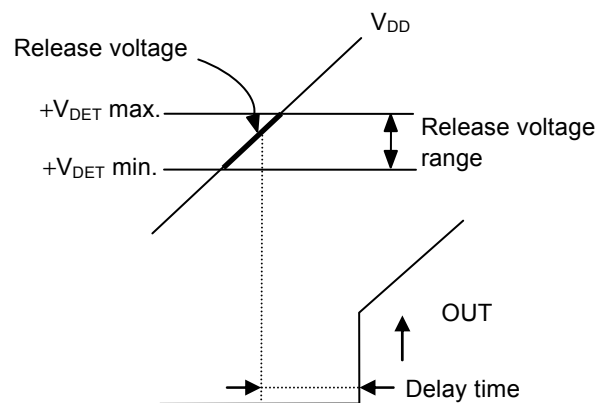
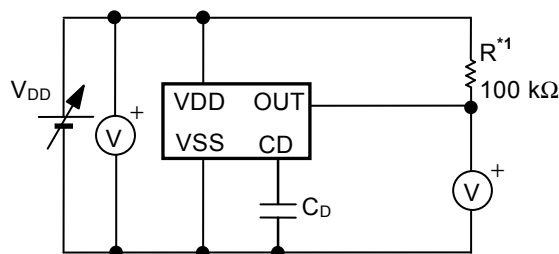

Figure 17 Release Voltage



*1. R is unnecessary for CMOS output product.

Figure 18 Test Circuit of Detection Voltage and Release Voltage

3. Hysteresis width (V_{HYS})

The hysteresis width is the voltage difference between the detection voltage and the release voltage (the voltage at point B – the voltage at point A = V_{HYS} in "Figure 13 Operation 2"). Setting the hysteresis width between the detection voltage and the release voltage to prevent malfunction caused by noise on the input voltage.

4. Delay time (t_D)

The delay time in the S-19100xxxA Series is a period from the input voltage to the VDD pin exceeding the release voltage ($+V_{DET}$) until the output from the OUT pin inverts. The delay time changes according to the delay capacitor (C_D).

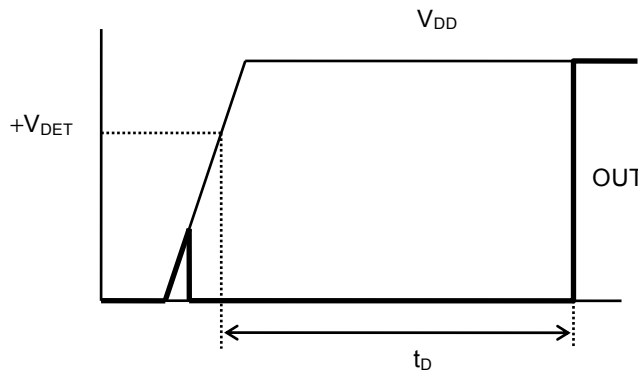

Figure 19 Delay Time

5. Feed-through current

Feed-through current is a current that flows instantaneously at the time of detection and release of a voltage detector. The feed-through current is large in CMOS output product, small in Nch open-drain output product.

6. Oscillation

In applications where a resistor is connected to the voltage detector input (Figure 20), taking a CMOS output (active "L") product for example, the feed-through current which is generated when the output goes from "L" to "H" (release) causes a voltage drop equal to [feed-through current] × [input resistance] across the resistor. When the input voltage drops below the detection voltage ($-V_{DET}$) as a result, the output voltage goes to low level. In this state, the feed-through current stops and its resultant voltage drop disappears, and the output goes from "L" to "H". The feed-through current is then generated again, a voltage drop appears, and repeating the process finally induces oscillation.

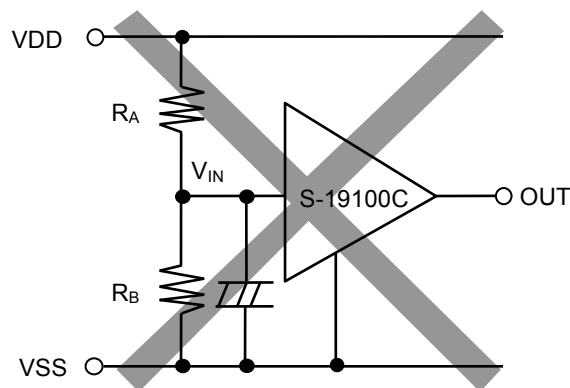

Figure 20 Example for Bad Implementation Due to Detection Voltage Change

■ Precautions

- Do not apply an electrostatic discharge to this IC that exceeds the performance ratings of the built-in electrostatic protection circuit.
- In CMOS output product, the feed-through current flows at the detection and the release. If the input impedance is high, oscillation may occur due to the voltage drop by the feed-through current during releasing.
- In CMOS output product, oscillation may occur when a pull-down resistor is used, and falling speed of the power supply voltage (V_{DD}) is slow near the detection voltage.
- When designing for mass production using an application circuit described herein, the product deviation and temperature characteristics of the external parts should be taken into consideration. SII Semiconductor Corporation shall not bear any responsibility for patent infringements related to products using the circuits described herein.
- SII Semiconductor Corporation claims no responsibility for any disputes arising out of or in connection with any infringement by products including this IC of patents owned by a third party.

■ **Characteristics (Typical Data)**

1. Detection voltage (V_{DET}) vs. Temperature (T_a)

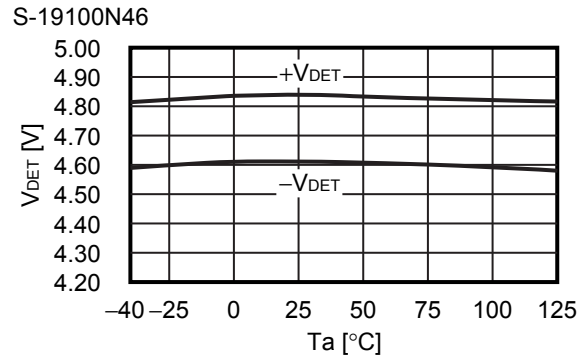
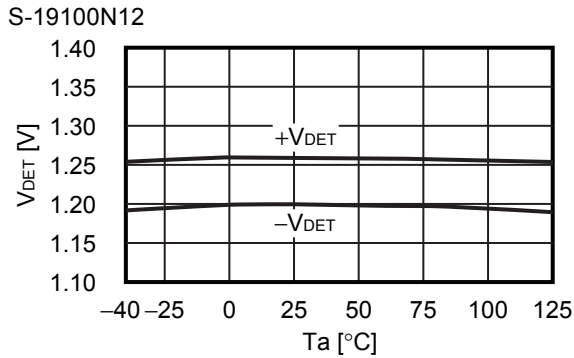

2. Hysteresis width (V_{HYS}) vs. Temperature (T_a)

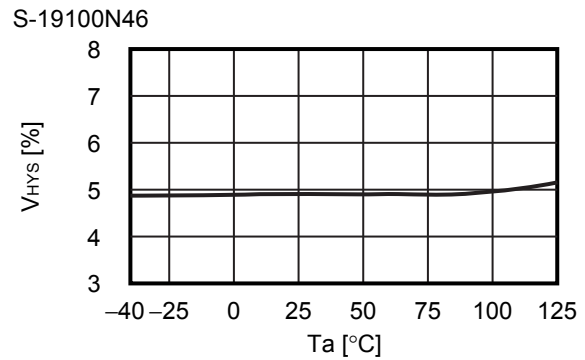
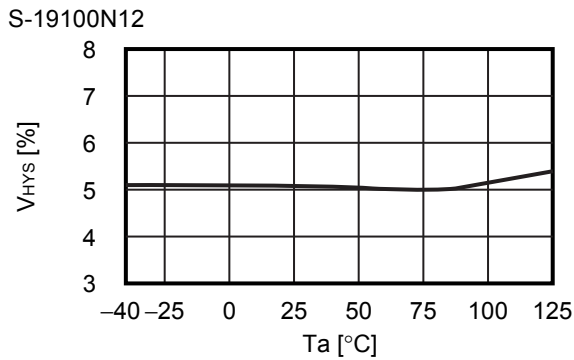

3. Current consumption (I_{SS}) vs. Input voltage (V_{DD})

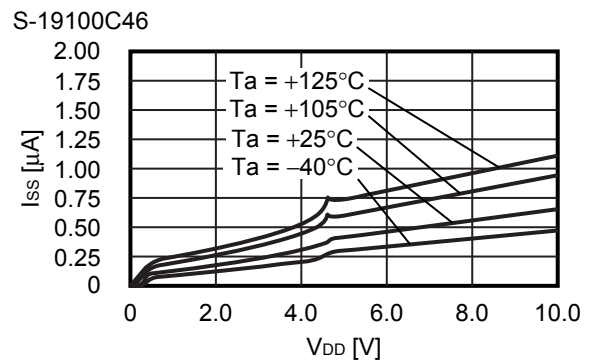
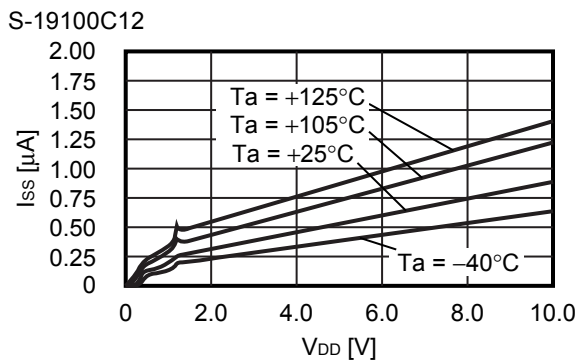

4. Current consumption (I_{SS}) vs. Temperature (T_a)

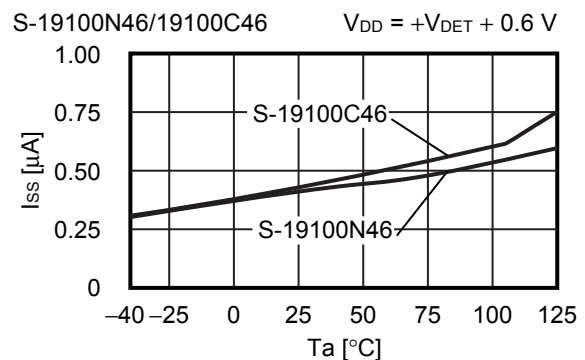
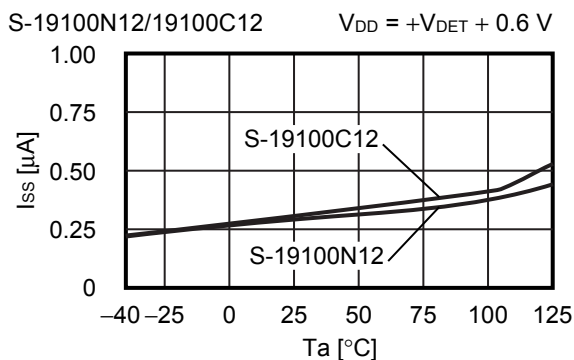

5. Nch transistor output current (I_{OUT}) vs. V_{DS}

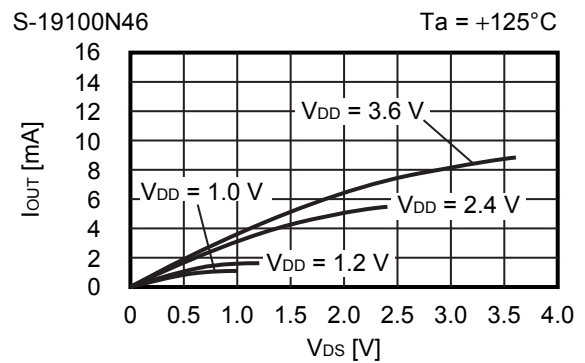
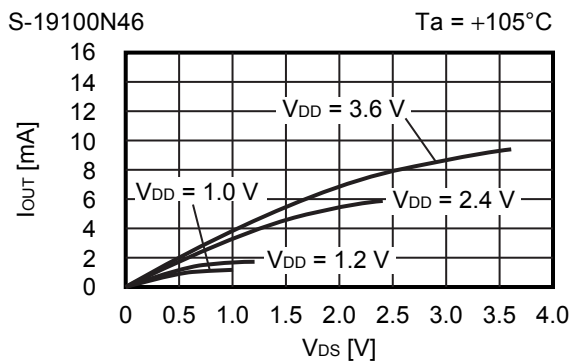
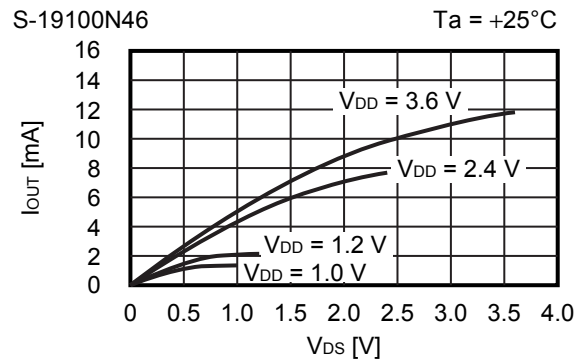
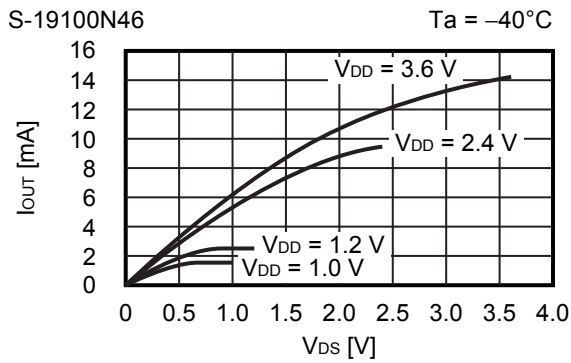

6. Pch transistor output current (I_{OUT}) vs. V_{DS}

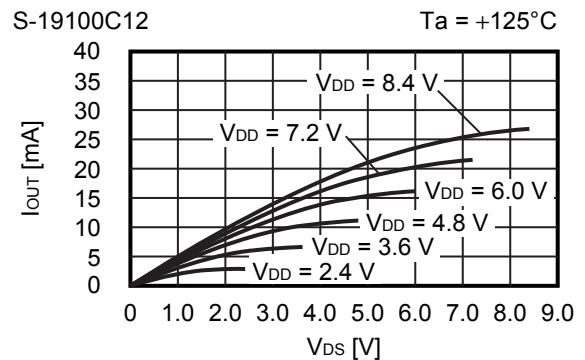
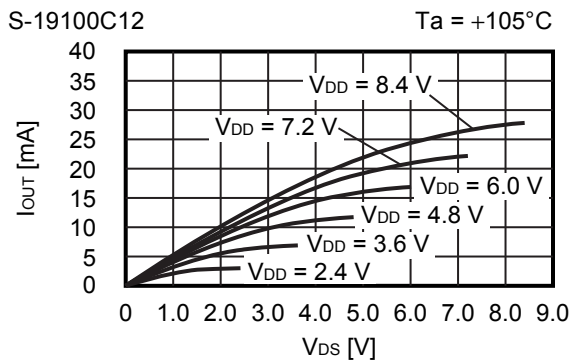
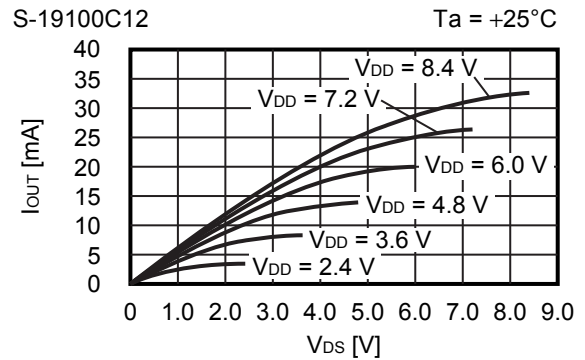
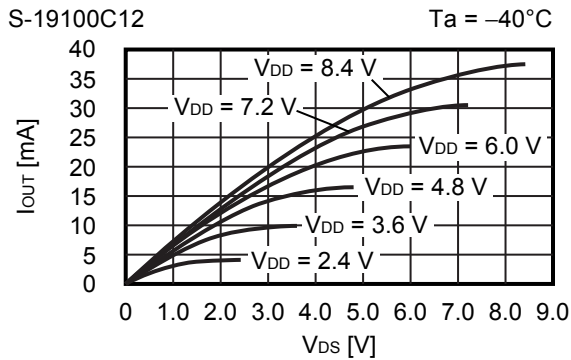

Remark V_{DS} : Drain-to-source voltage of the output transistor

7. Nch transistor output current (I_{OUT}) vs. Input voltage (V_{DD})

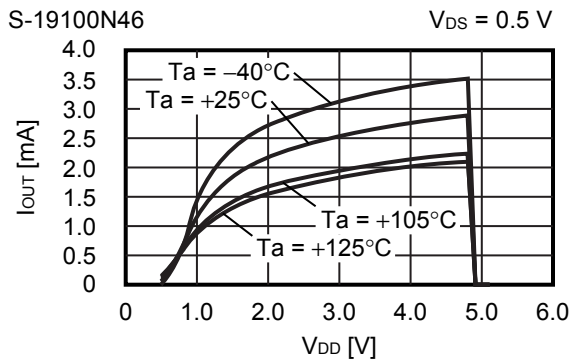

8. Pch transistor output current (I_{OUT}) vs. Input voltage (V_{DD})

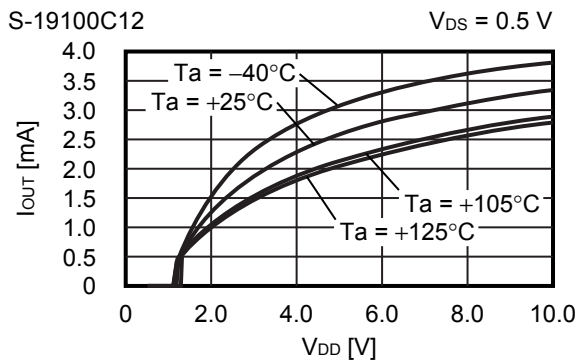

9. Minimum operation voltage (V_{OUT}) vs. Input voltage (V_{DD})

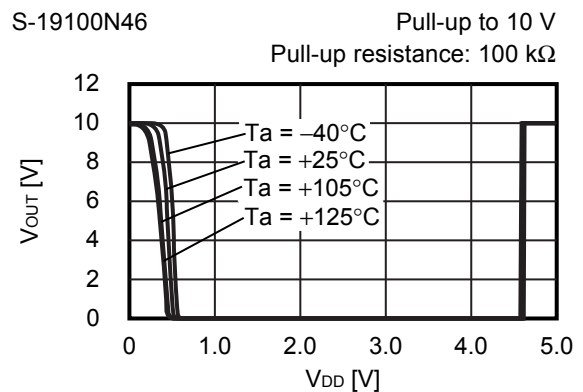
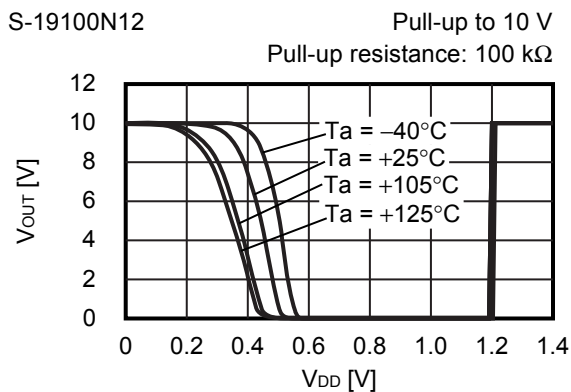
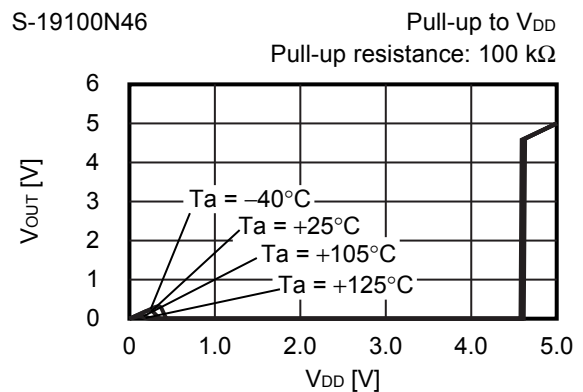
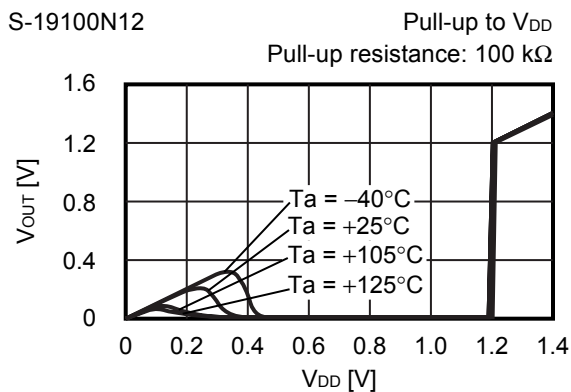

Remark V_{DS} : Drain-to-source voltage of the output transistor

10. Dynamic response characteristics vs. Output pin capacitance (C_{OUT}) (CD pin; open)

10.1 -V_{DET} = 1.2 V

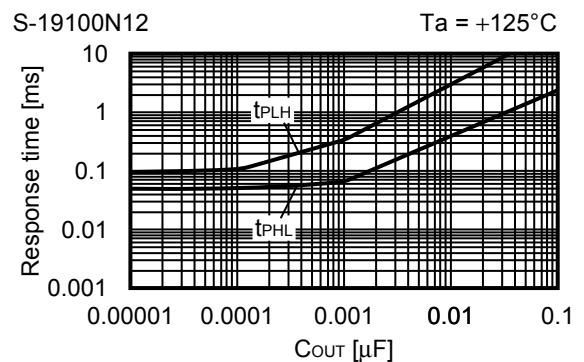
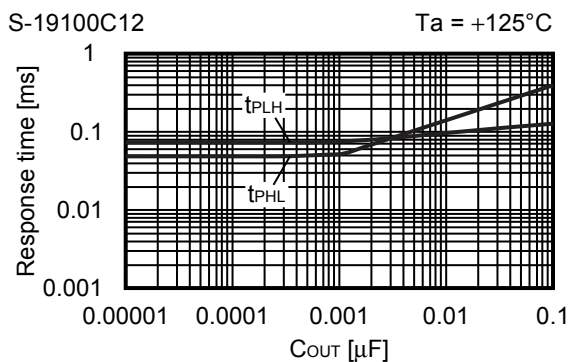
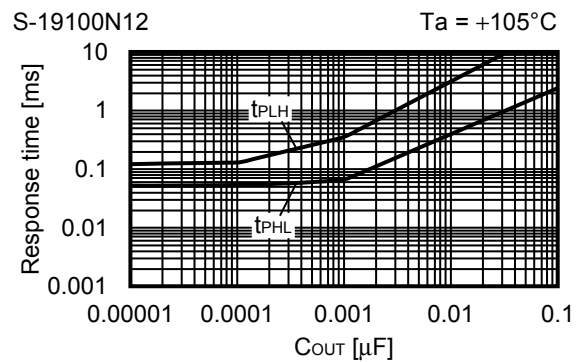
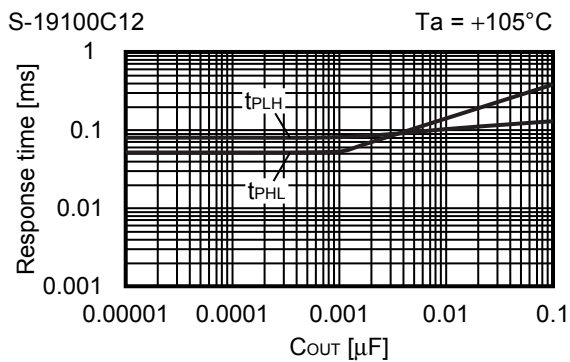
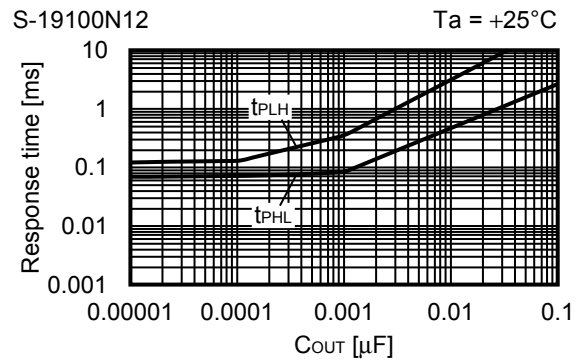
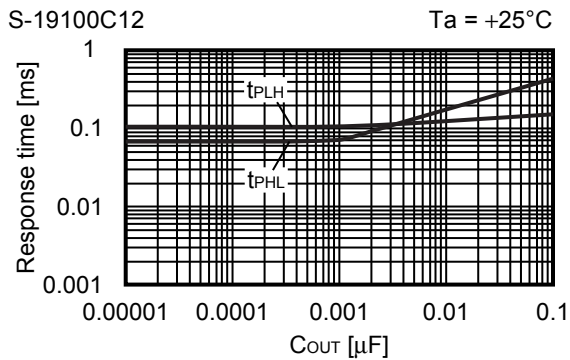
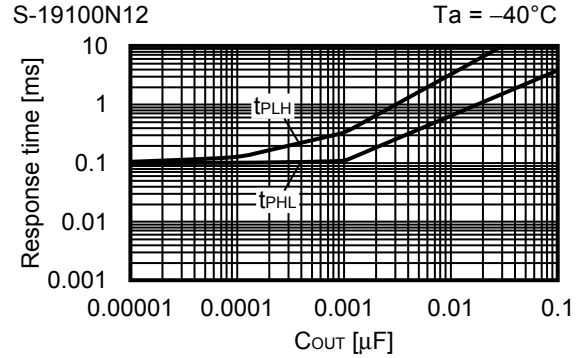
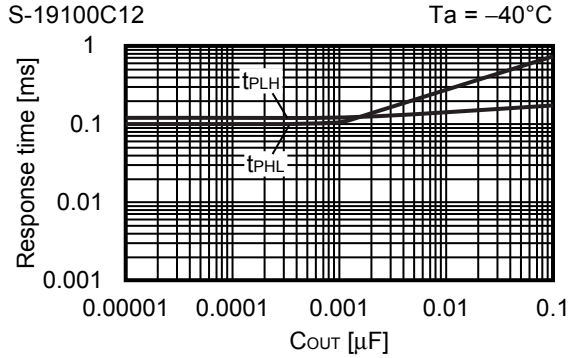

10.2 $-V_{DET} = 4.6 V$

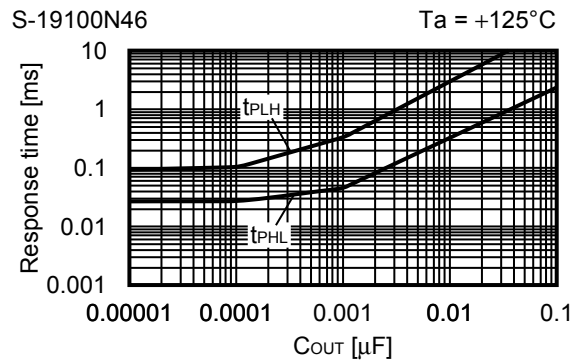
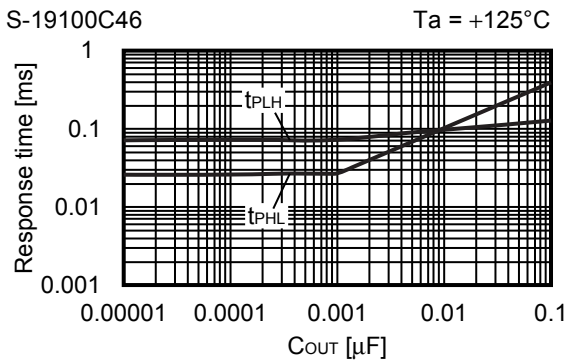
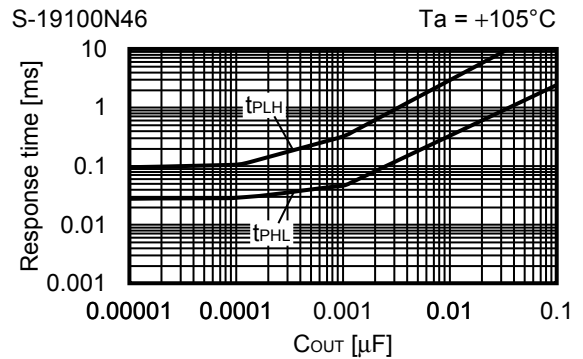
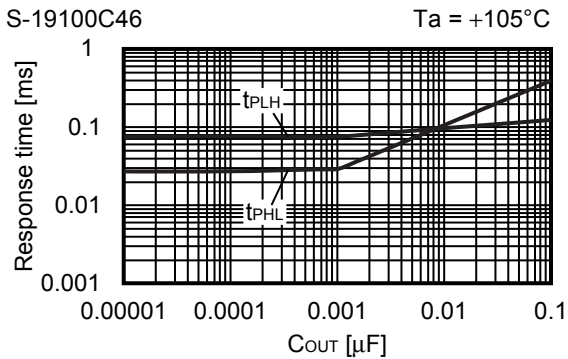
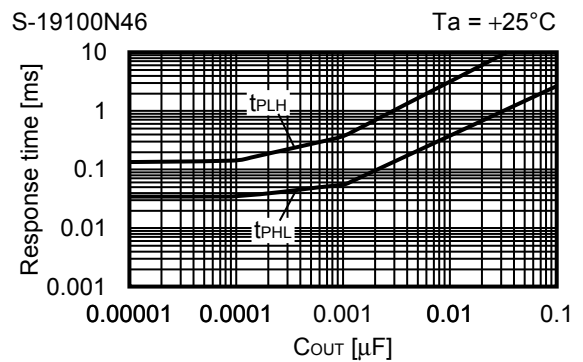
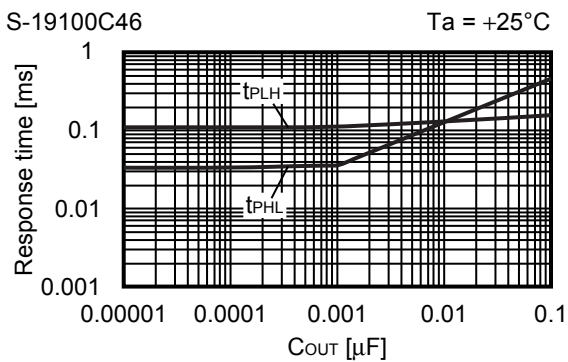
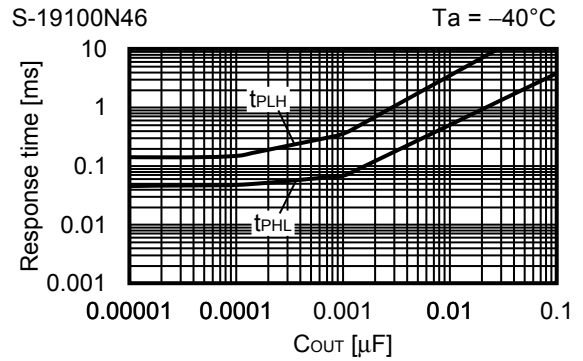
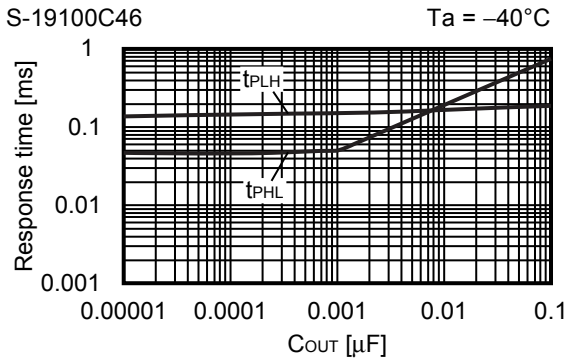

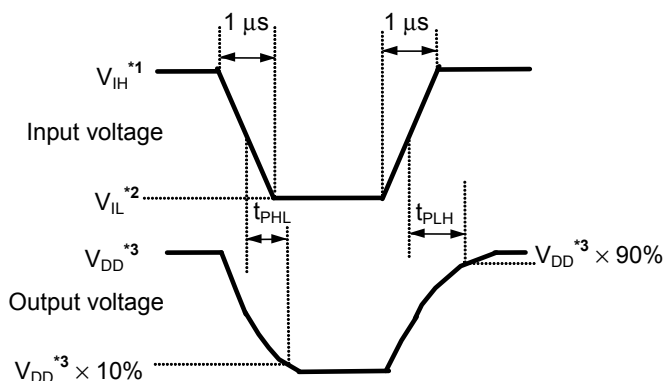

- *1. $V_{IH} = 10\text{ V}$
- *2. $V_{IL} = 0.8\text{ V}$
- *3. CMOS output product: V_{DD}
 Nch open-drain product: V_{DD1}

Figure 21 Test Condition of Response Time

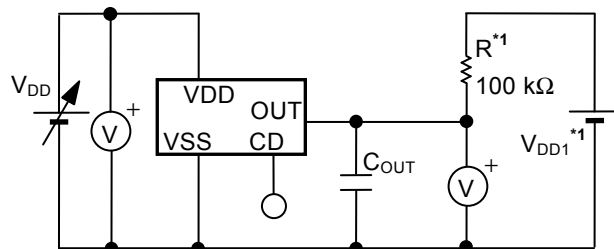

- *1. R and V_{DD1} are unnecessary for CMOS output product.

Figure 22 Test Circuit of Response Time

- Caution**
1. The above connection diagram and constant will not guarantee successful operation. Perform thorough evaluation using the actual application to set the constant.
 2. When the CD pin is open, a double pulse may appear at release. To avoid the double pulse, attach 100 pF or more capacitor to the CD pin. Response time when detecting (t_{PHL}) is not affected by CD pin capacitance. Besides, response time when releasing (t_{PLH}) can be set the delay time by attaching CD pin. Refer to "11. Delay time (t_D) vs. CD pin capacitance (C_D) (without output pin capacitance) for details.

11. Delay time (t_D) vs. CD pin capacitance (C_D) (without output pin capacitance)

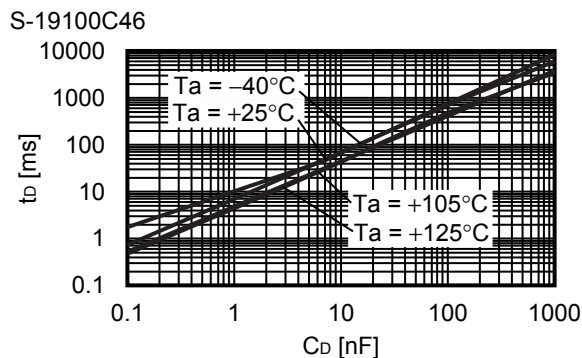
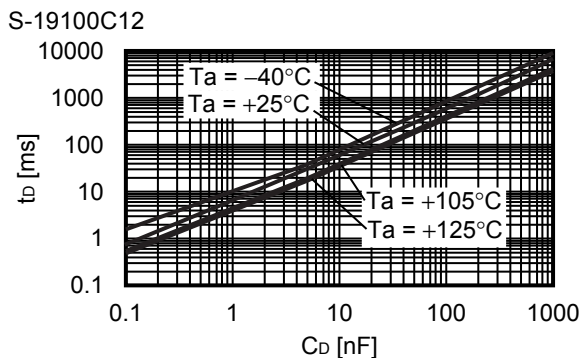

12. Delay time (t_D) vs. Temperature (T_a)

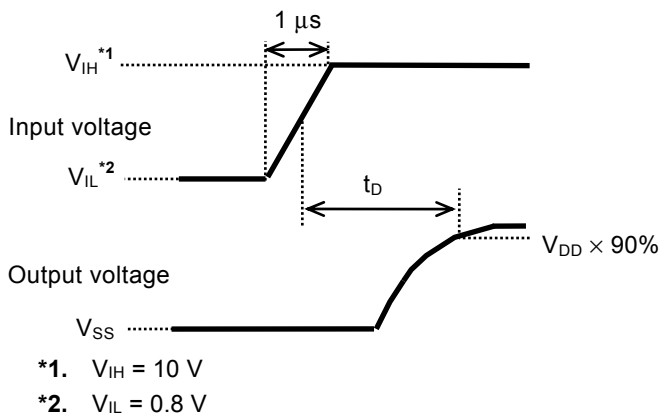
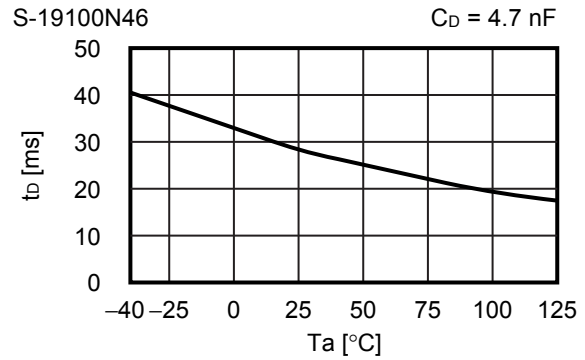
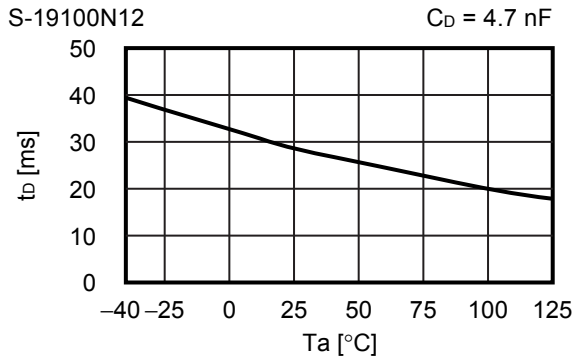

Figure 23 Test Condition of Delay Time

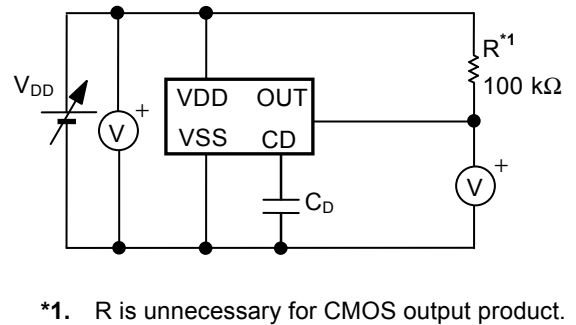

Figure 24 Test Circuit of Delay Time

Caution The above connection diagram and constant will not guarantee successful operation. Perform thorough evaluation using the actual application to set the constant.

■ Application Circuit Examples

1. Microcomputer reset circuits

In microcomputers, when the power supply voltage is lower than the minimum operation voltage, an unspecified operation may be performed or the contents of the memory register may be lost. When power supply voltage returns to the normal level, the microcomputer needs to be initialized. Otherwise, the microcomputer may malfunction after that. Reset circuits to protect microcomputer in the event of current being momentarily switched off or lowered.

Using the S-19100xxxA Series which has the low minimum operation voltage, a high-accuracy detection voltage and hysteresis, reset circuits can be easily constructed as seen in **Figure 25** and **Figure 26**.

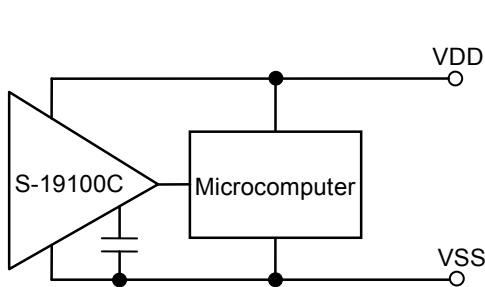

Figure 25 Example of Reset Circuit
(CMOS Output Product)

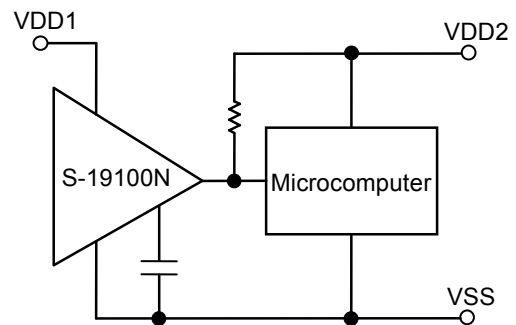
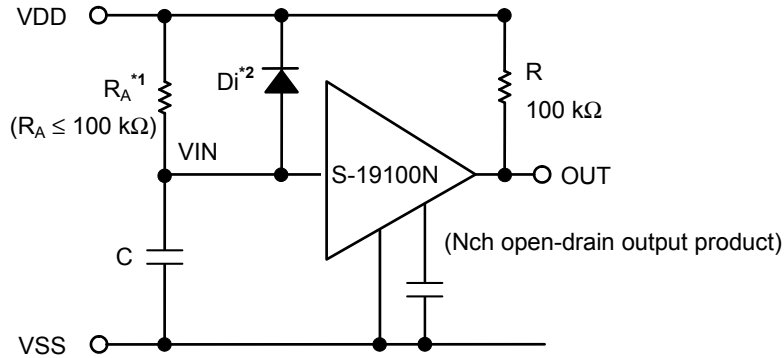

Figure 26 Example of Reset Circuit
(Nch Open-drain Output Product)

Caution The above connection diagram and constant will not guarantee successful operation. Perform thorough evaluation using the actual application to set the constant.

2. Power-on reset circuit (Nch open-drain output product only)

A power-on reset circuit can be constructed using the S-19100NxxA Series.



- *1. R_A should be 100 kΩ or less to prevent oscillation.
- *2. Diode (Di) instantaneously discharges the charge stored in the capacitor (C) at the power falling. Di can be removed when the delay of the falling time is not important.

Figure 27

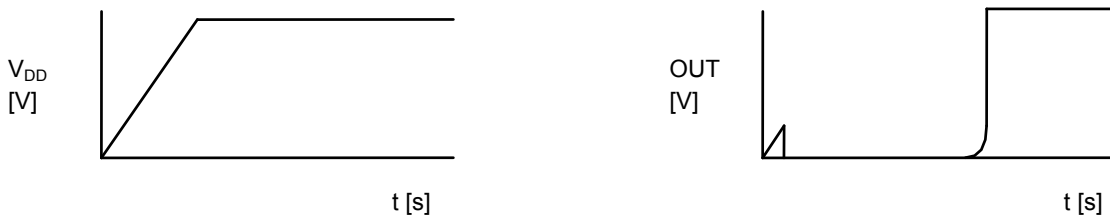

Figure 28

Remark When the power rises sharply, the output may instantaneously be set to the "H" level due to the IC's indefinite area (the output voltage is indefinite when it is the IC's minimum operation voltage or less), as seen in **Figure 29**.

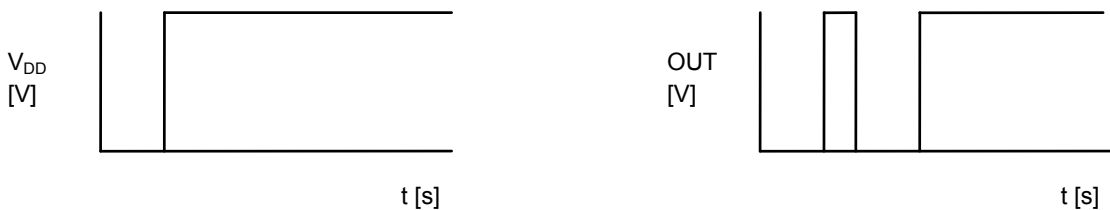

Figure 29

- Caution**
1. The above connection diagram and constant will not guarantee successful operation. Perform thorough evaluation using the actual application to set the constant.
 2. Note that the hysteresis width may be larger as the following equation shows when using the above connection. Perform thorough evaluation using the actual application to set the constant.

$$\text{Maximum hysteresis width} = V_{HYS} + R_A \cdot 20 \mu A$$

3. Change of detection voltage (Nch open-drain output product only)

If there is not a product with a specified detection voltage value in the S-19100NxxA Series, the detection voltage can be changed by using a resistance divider or a diode, as seen in **Figure 30** and **Figure 31**.

In **Figure 31**, the hysteresis width also changes.

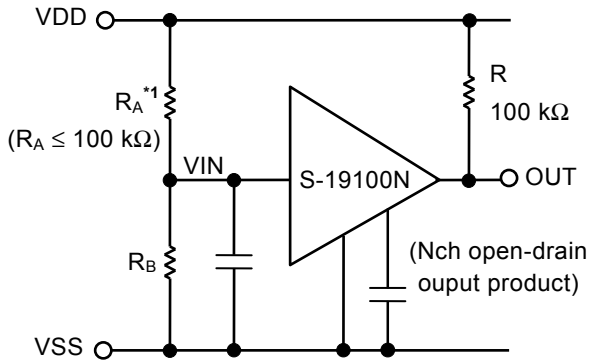

$$\text{Detection voltage} = \frac{R_A + R_B}{R_B} \cdot -V_{DET}$$

$$\text{Hysteresis width} = \frac{R_A + R_B}{R_B} \cdot V_{HYS}$$

*1. RA should be 100 kΩ or less to prevent oscillation.

Caution If RA and RB are large, the hysteresis width may also be larger than the value given by the above equation due to the feed-through current.

Figure 30

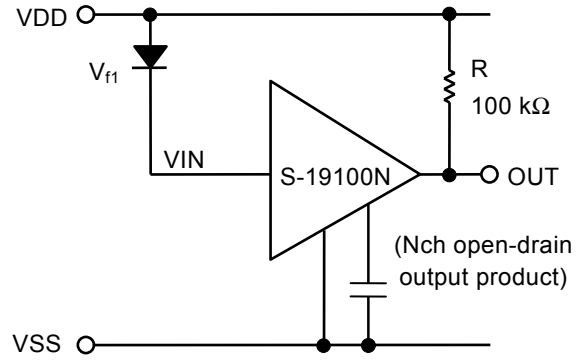

$$\text{Detection voltage} = V_{f1} + (-V_{DET})$$

Figure 31

- Caution**
- The above connection diagram and constant will not guarantee successful operation. Perform thorough evaluation using the actual application to set the constant.
 - Note that the hysteresis width may be larger as the following equation shows when using the above connections. Perform thorough evaluation using the actual application to set the constant.

$$\text{Maximum hysteresis width} = \frac{R_A + R_B}{R_B} \cdot V_{HYS} + R_A \cdot 20 \mu\text{A}$$

■ Marking Specifications

1. SOT-23-5

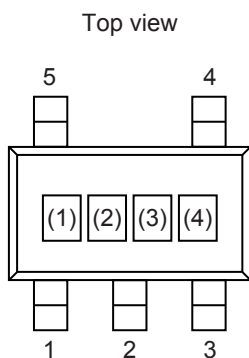

(1) to (3): Product code (Refer to **Product name vs. Product code**)
 (4): Lot number

Product name vs. Product code

1.1 Nch open-drain output product

| Product Name | Product Code | | |
|-------------------|--------------|-----|-----|
| | (1) | (2) | (3) |
| S-19100N12A-M5T2U | 3 | N | A |
| S-19100N13A-M5T2U | 3 | N | B |
| S-19100N14A-M5T2U | 3 | N | C |
| S-19100N15A-M5T2U | 3 | N | D |
| S-19100N16A-M5T2U | 3 | N | E |
| S-19100N17A-M5T2U | 3 | N | F |
| S-19100N18A-M5T2U | 3 | N | G |
| S-19100N19A-M5T2U | 3 | N | H |
| S-19100N20A-M5T2U | 3 | N | I |
| S-19100N21A-M5T2U | 3 | N | J |
| S-19100N22A-M5T2U | 3 | N | K |
| S-19100N23A-M5T2U | 3 | N | L |
| S-19100N24A-M5T2U | 3 | N | M |
| S-19100N25A-M5T2U | 3 | N | N |
| S-19100N26A-M5T2U | 3 | N | O |
| S-19100N27A-M5T2U | 3 | N | P |
| S-19100N28A-M5T2U | 3 | N | Q |
| S-19100N29A-M5T2U | 3 | N | R |
| S-19100N30A-M5T2U | 3 | N | S |
| S-19100N31A-M5T2U | 3 | N | T |
| S-19100N32A-M5T2U | 3 | N | U |
| S-19100N33A-M5T2U | 3 | N | V |
| S-19100N34A-M5T2U | 3 | N | W |
| S-19100N35A-M5T2U | 3 | N | X |
| S-19100N36A-M5T2U | 3 | N | Y |
| S-19100N37A-M5T2U | 3 | N | Z |
| S-19100N38A-M5T2U | 3 | N | 1 |
| S-19100N39A-M5T2U | 3 | N | 2 |
| S-19100N40A-M5T2U | 3 | N | 3 |
| S-19100N41A-M5T2U | 3 | N | 4 |
| S-19100N42A-M5T2U | 3 | N | 5 |
| S-19100N43A-M5T2U | 3 | N | 6 |
| S-19100N44A-M5T2U | 3 | N | 7 |
| S-19100N45A-M5T2U | 3 | N | 8 |
| S-19100N46A-M5T2U | 3 | N | 9 |

1.2 CMOS output product

| Product Name | Product Code | | |
|-------------------|--------------|-----|-----|
| | (1) | (2) | (3) |
| S-19100C12A-M5T2U | 3 | M | A |
| S-19100C13A-M5T2U | 3 | M | B |
| S-19100C14A-M5T2U | 3 | M | C |
| S-19100C15A-M5T2U | 3 | M | D |
| S-19100C16A-M5T2U | 3 | M | E |
| S-19100C17A-M5T2U | 3 | M | F |
| S-19100C18A-M5T2U | 3 | M | G |
| S-19100C19A-M5T2U | 3 | M | H |
| S-19100C20A-M5T2U | 3 | M | I |
| S-19100C21A-M5T2U | 3 | M | J |
| S-19100C22A-M5T2U | 3 | M | K |
| S-19100C23A-M5T2U | 3 | M | L |
| S-19100C24A-M5T2U | 3 | M | M |
| S-19100C25A-M5T2U | 3 | M | N |
| S-19100C26A-M5T2U | 3 | M | O |
| S-19100C27A-M5T2U | 3 | M | P |
| S-19100C28A-M5T2U | 3 | M | Q |
| S-19100C29A-M5T2U | 3 | M | R |
| S-19100C30A-M5T2U | 3 | M | S |
| S-19100C31A-M5T2U | 3 | M | T |
| S-19100C32A-M5T2U | 3 | M | U |
| S-19100C33A-M5T2U | 3 | M | V |
| S-19100C34A-M5T2U | 3 | M | W |
| S-19100C35A-M5T2U | 3 | M | X |
| S-19100C36A-M5T2U | 3 | M | Y |
| S-19100C37A-M5T2U | 3 | M | Z |
| S-19100C38A-M5T2U | 3 | M | 1 |
| S-19100C39A-M5T2U | 3 | M | 2 |
| S-19100C40A-M5T2U | 3 | M | 3 |
| S-19100C41A-M5T2U | 3 | M | 4 |
| S-19100C42A-M5T2U | 3 | M | 5 |
| S-19100C43A-M5T2U | 3 | M | 6 |
| S-19100C44A-M5T2U | 3 | M | 7 |
| S-19100C45A-M5T2U | 3 | M | 8 |
| S-19100C46A-M5T2U | 3 | M | 9 |

2. SC-82AB

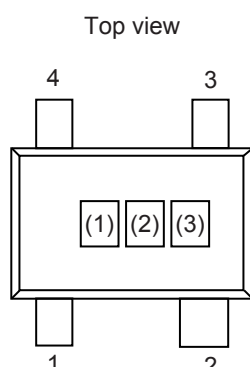

(1) to (3): Product code (Refer to **Product name vs. Product code**)

Product name vs. Product code

2.1 Nch open-drain output product

| Product Name | Product Code | | |
|-------------------|--------------|-----|-----|
| | (1) | (2) | (3) |
| S-19100N12A-N4T2U | 3 | N | A |
| S-19100N13A-N4T2U | 3 | N | B |
| S-19100N14A-N4T2U | 3 | N | C |
| S-19100N15A-N4T2U | 3 | N | D |
| S-19100N16A-N4T2U | 3 | N | E |
| S-19100N17A-N4T2U | 3 | N | F |
| S-19100N18A-N4T2U | 3 | N | G |
| S-19100N19A-N4T2U | 3 | N | H |
| S-19100N20A-N4T2U | 3 | N | I |
| S-19100N21A-N4T2U | 3 | N | J |
| S-19100N22A-N4T2U | 3 | N | K |
| S-19100N23A-N4T2U | 3 | N | L |
| S-19100N24A-N4T2U | 3 | N | M |
| S-19100N25A-N4T2U | 3 | N | N |
| S-19100N26A-N4T2U | 3 | N | O |
| S-19100N27A-N4T2U | 3 | N | P |
| S-19100N28A-N4T2U | 3 | N | Q |
| S-19100N29A-N4T2U | 3 | N | R |
| S-19100N30A-N4T2U | 3 | N | S |
| S-19100N31A-N4T2U | 3 | N | T |
| S-19100N32A-N4T2U | 3 | N | U |
| S-19100N33A-N4T2U | 3 | N | V |
| S-19100N34A-N4T2U | 3 | N | W |
| S-19100N35A-N4T2U | 3 | N | X |
| S-19100N36A-N4T2U | 3 | N | Y |
| S-19100N37A-N4T2U | 3 | N | Z |
| S-19100N38A-N4T2U | 3 | N | 1 |
| S-19100N39A-N4T2U | 3 | N | 2 |
| S-19100N40A-N4T2U | 3 | N | 3 |
| S-19100N41A-N4T2U | 3 | N | 4 |
| S-19100N42A-N4T2U | 3 | N | 5 |
| S-19100N43A-N4T2U | 3 | N | 6 |
| S-19100N44A-N4T2U | 3 | N | 7 |
| S-19100N45A-N4T2U | 3 | N | 8 |
| S-19100N46A-N4T2U | 3 | N | 9 |

2.2 CMOS output product

| Product Name | Product Code | | |
|-------------------|--------------|-----|-----|
| | (1) | (2) | (3) |
| S-19100C12A-N4T2U | 3 | M | A |
| S-19100C13A-N4T2U | 3 | M | B |
| S-19100C14A-N4T2U | 3 | M | C |
| S-19100C15A-N4T2U | 3 | M | D |
| S-19100C16A-N4T2U | 3 | M | E |
| S-19100C17A-N4T2U | 3 | M | F |
| S-19100C18A-N4T2U | 3 | M | G |
| S-19100C19A-N4T2U | 3 | M | H |
| S-19100C20A-N4T2U | 3 | M | I |
| S-19100C21A-N4T2U | 3 | M | J |
| S-19100C22A-N4T2U | 3 | M | K |
| S-19100C23A-N4T2U | 3 | M | L |
| S-19100C24A-N4T2U | 3 | M | M |
| S-19100C25A-N4T2U | 3 | M | N |
| S-19100C26A-N4T2U | 3 | M | O |
| S-19100C27A-N4T2U | 3 | M | P |
| S-19100C28A-N4T2U | 3 | M | Q |
| S-19100C29A-N4T2U | 3 | M | R |
| S-19100C30A-N4T2U | 3 | M | S |
| S-19100C31A-N4T2U | 3 | M | T |
| S-19100C32A-N4T2U | 3 | M | U |
| S-19100C33A-N4T2U | 3 | M | V |
| S-19100C34A-N4T2U | 3 | M | W |
| S-19100C35A-N4T2U | 3 | M | X |
| S-19100C36A-N4T2U | 3 | M | Y |
| S-19100C37A-N4T2U | 3 | M | Z |
| S-19100C38A-N4T2U | 3 | M | 1 |
| S-19100C39A-N4T2U | 3 | M | 2 |
| S-19100C40A-N4T2U | 3 | M | 3 |
| S-19100C41A-N4T2U | 3 | M | 4 |
| S-19100C42A-N4T2U | 3 | M | 5 |
| S-19100C43A-N4T2U | 3 | M | 6 |
| S-19100C44A-N4T2U | 3 | M | 7 |
| S-19100C45A-N4T2U | 3 | M | 8 |
| S-19100C46A-N4T2U | 3 | M | 9 |

■ **Thermal Characteristics**

1. **SOT-23-5**

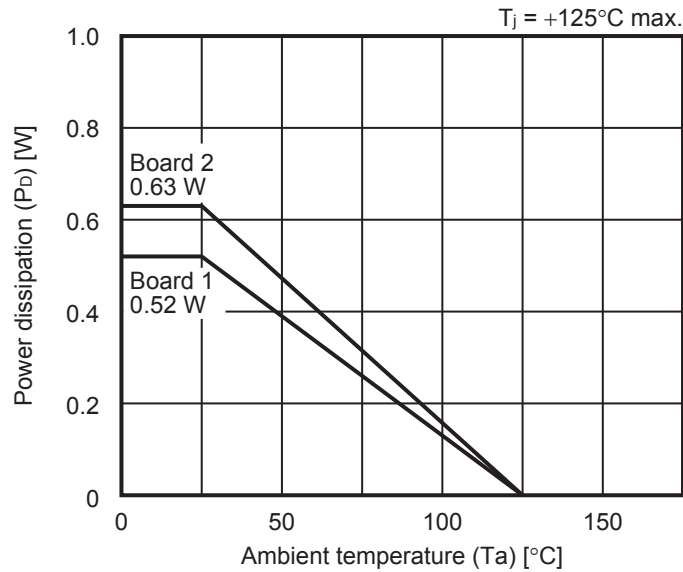

Figure 32 Power Dissipation of Package (When Mounted on Board)

1.1 **Board 1***

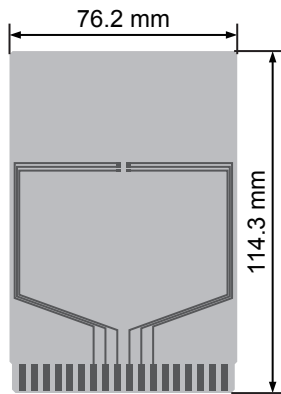

Figure 33

Table 12

| Item | Specification | |
|--|------------------------------|--|
| Thermal resistance value (θ_{ja}) | 192°C/W | |
| Size | 114.3 mm × 76.2 mm × t1.6 mm | |
| Material | FR-4 | |
| Number of copper foil layer | 2 | |
| Copper foil layer | 1 | Land pattern and wiring for testing: t0.070 mm |
| | 2 | — |
| | 3 | — |
| | 4 | 74.2 mm × 74.2 mm × t0.070 mm |
| Thermal via | — | |

1.2 **Board 2***

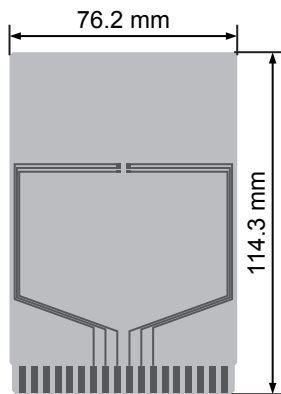

Figure 34

Table 13

| Item | Specification | |
|--|------------------------------|--|
| Thermal resistance value (θ_{ja}) | 160°C/W | |
| Size | 114.3 mm × 76.2 mm × t1.6 mm | |
| Material | FR-4 | |
| Number of copper foil layer | 4 | |
| Copper foil layer | 1 | Land pattern and wiring for testing: t0.070 mm |
| | 2 | 74.2 mm × 74.2 mm × t0.035 mm |
| | 3 | 74.2 mm × 74.2 mm × t0.035 mm |
| | 4 | 74.2 mm × 74.2 mm × t0.070 mm |
| Thermal via | — | |

*1. The board is same in SOT-23-3, SOT-23-5 and SOT-23-6.

2. SC-82AB

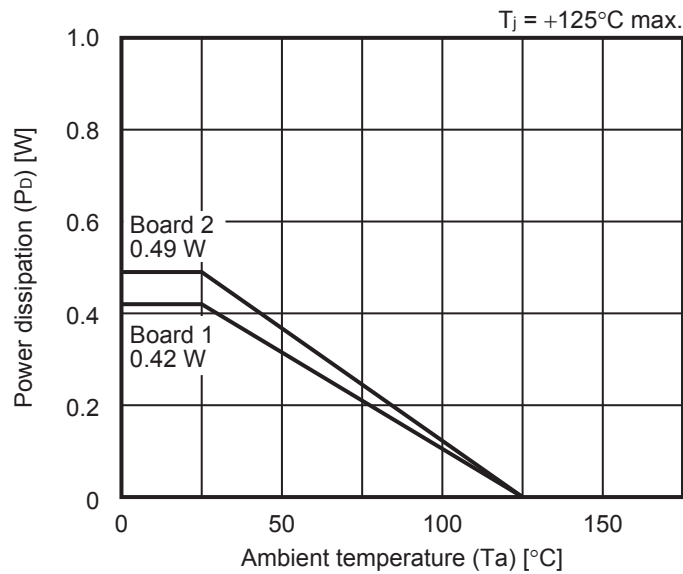

Figure 35 Power Dissipation of Package (When Mounted on Board)

2.1 Board 1

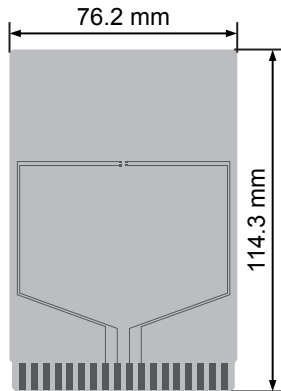

Figure 36

Table 14

| Item | Specification |
|--|--|
| Thermal resistance value (θ_{ja}) | 236°C/W |
| Size | 114.3 mm × 76.2 mm × t1.6 mm |
| Material | FR-4 |
| Number of copper foil layer | 2 |
| Copper foil layer | 1 Land pattern and wiring for testing: t0.070 mm |
| | 2 - |
| | 3 - |
| | 4 74.2 mm × 74.2 mm × t0.070 mm |
| Thermal via | - |

2.2 Board 2

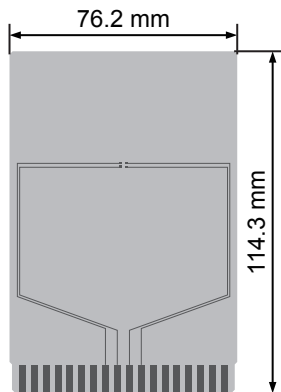
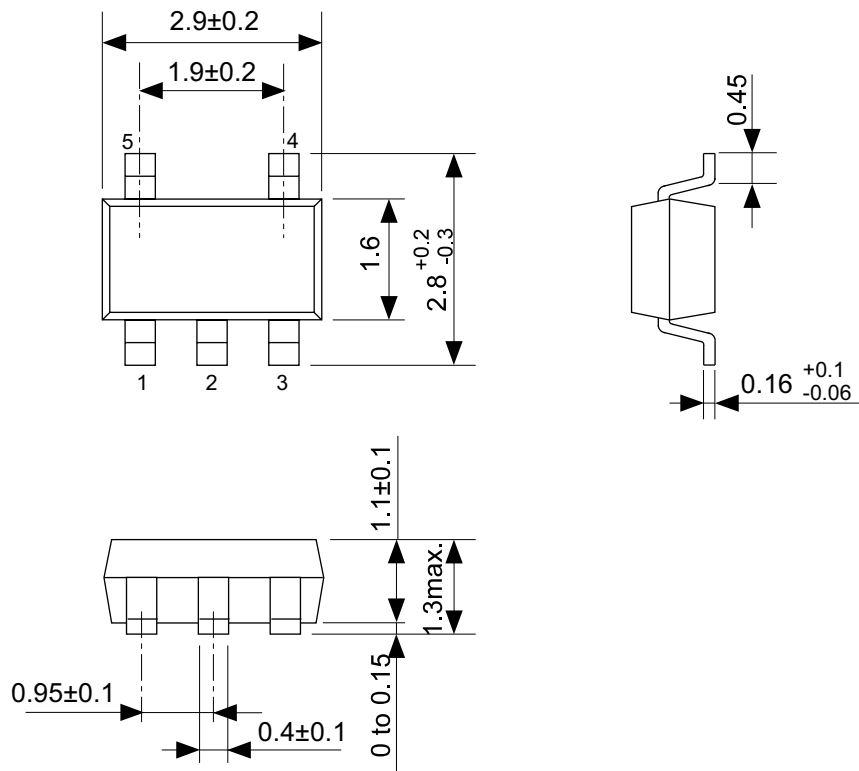

Figure 37

Table 15

| Item | Specification |
|--|--|
| Thermal resistance value (θ_{ja}) | 204°C/W |
| Size | 114.3 mm × 76.2 mm × t1.6 mm |
| Material | FR-4 |
| Number of copper foil layer | 4 |
| Copper foil layer | 1 Land pattern and wiring for testing: t0.070 mm |
| | 2 74.2 mm × 74.2 mm × t0.035 mm |
| | 3 74.2 mm × 74.2 mm × t0.035 mm |
| | 4 74.2 mm × 74.2 mm × t0.070 mm |
| Thermal via | - |



No. MP005-A-P-SD-1.2

| | |
|-------------------------------|-------------------------|
| TITLE | SOT235-A-PKG Dimensions |
| No. | MP005-A-P-SD-1.2 |
| SCALE | |
| UNIT | mm |
| SII Semiconductor Corporation | |

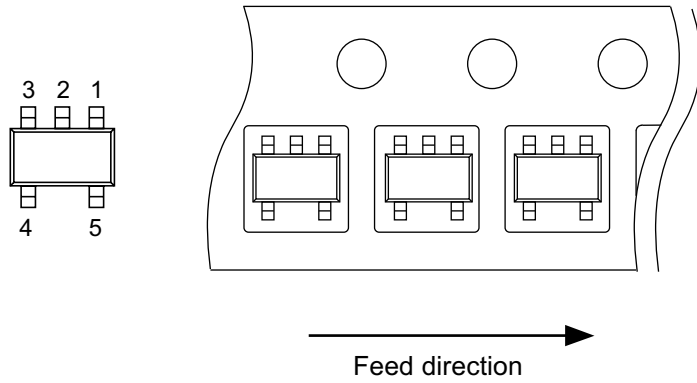
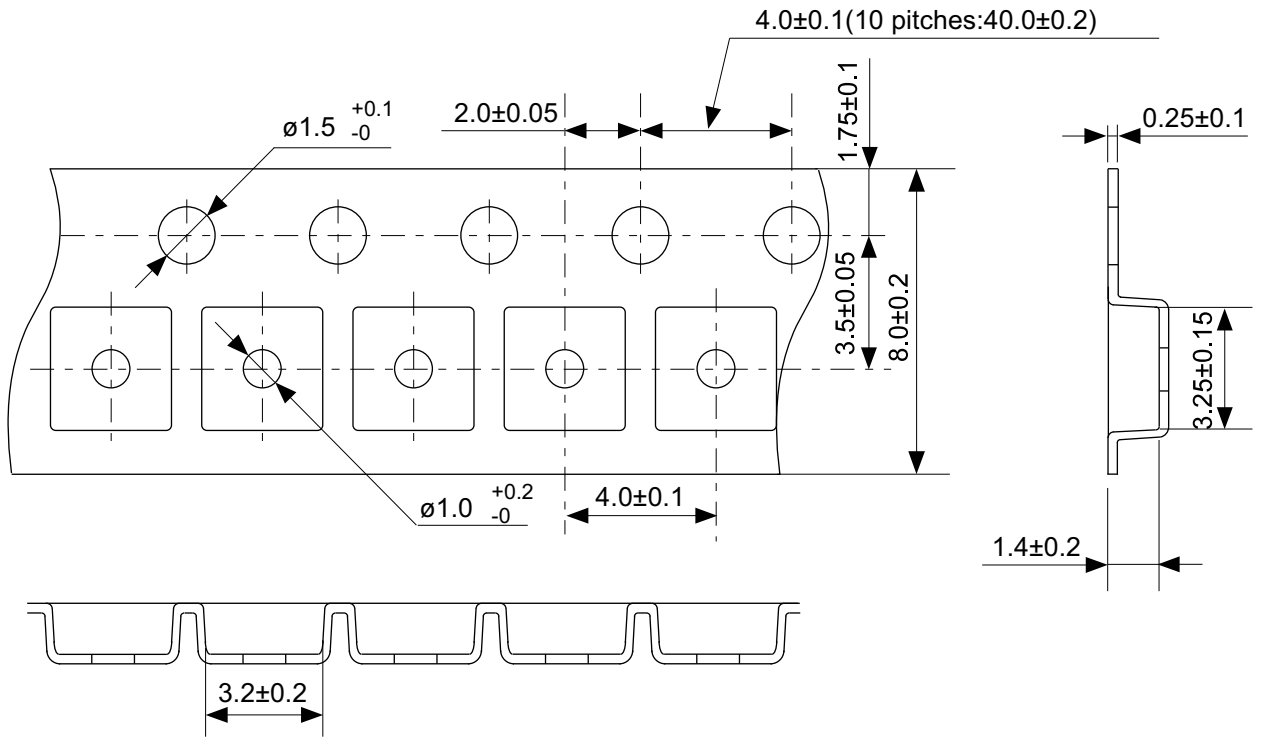

No. MP005-A-C-SD-2.1

| | |
|-------------------------------|-----------------------|
| TITLE | SOT235-A-Carrier Tape |
| No. | MP005-A-C-SD-2.1 |
| SCALE | |
| UNIT | mm |
| SII Semiconductor Corporation | |

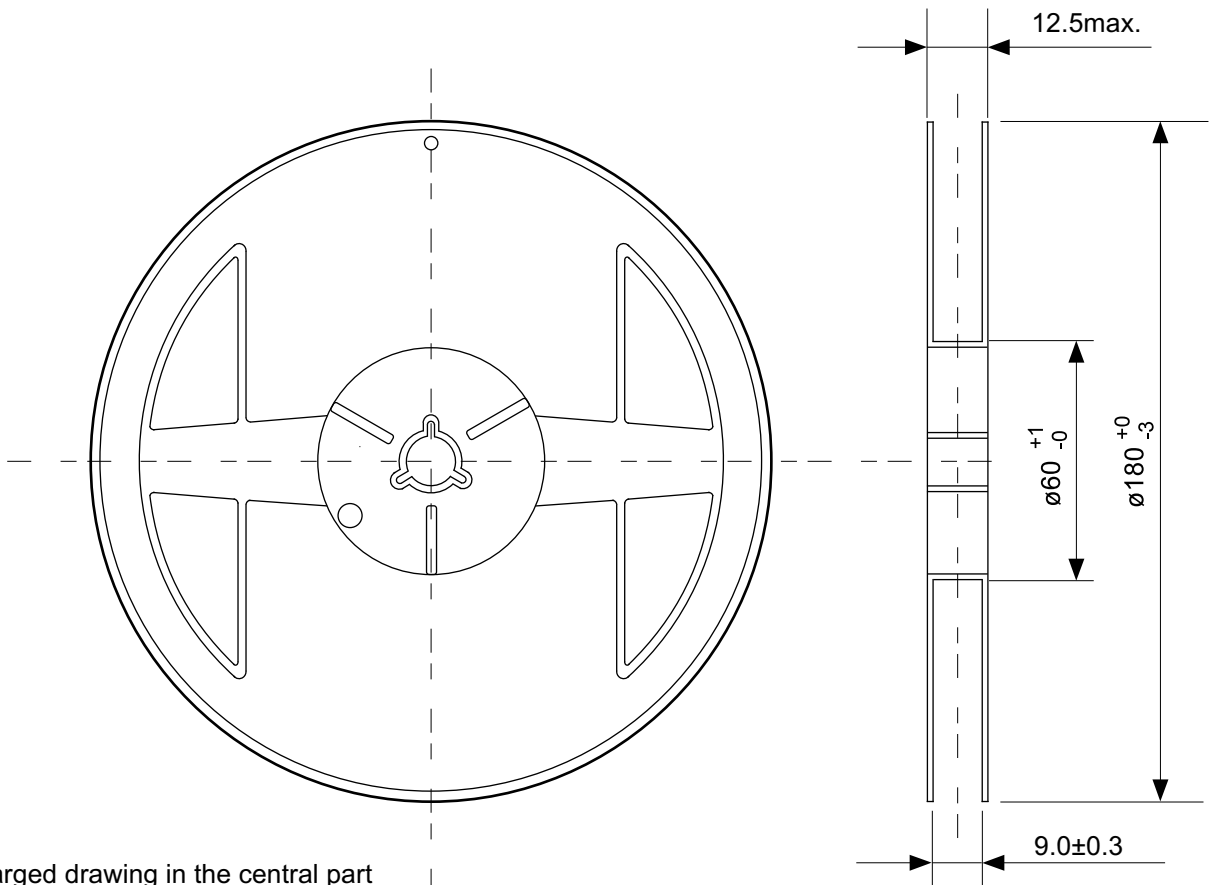

Enlarged drawing in the central part

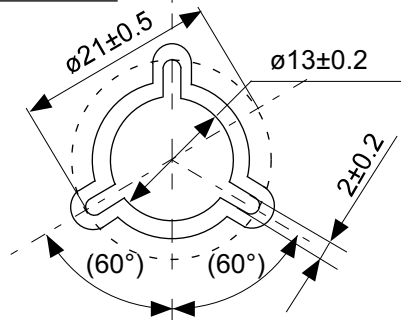

No. MP005-A-R-SD-1.1

| | | | |
|-------------------------------|------------------|------|-------|
| TITLE | SOT235-A-Reel | | |
| No. | MP005-A-R-SD-1.1 | | |
| SCALE | | QTY. | 3,000 |
| UNIT | mm | | |
| | | | |
| SII Semiconductor Corporation | | | |

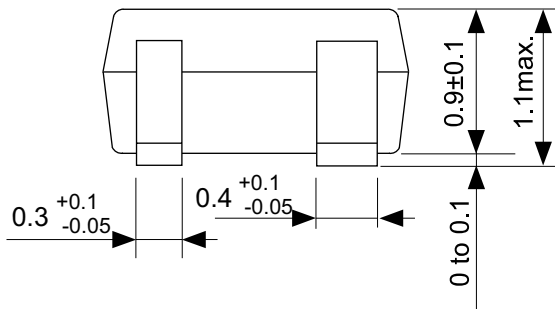
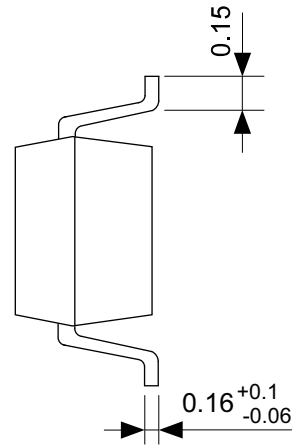
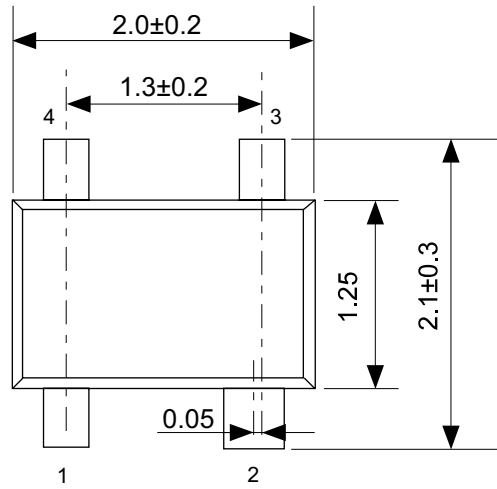

No. NP004-A-P-SD-1.1

| | |
|-------------------------------|-------------------------|
| TITLE | SC82AB-A-PKG Dimensions |
| No. | NP004-A-P-SD-1.1 |
| SCALE | |
| UNIT | mm |
| | |
| SII Semiconductor Corporation | |

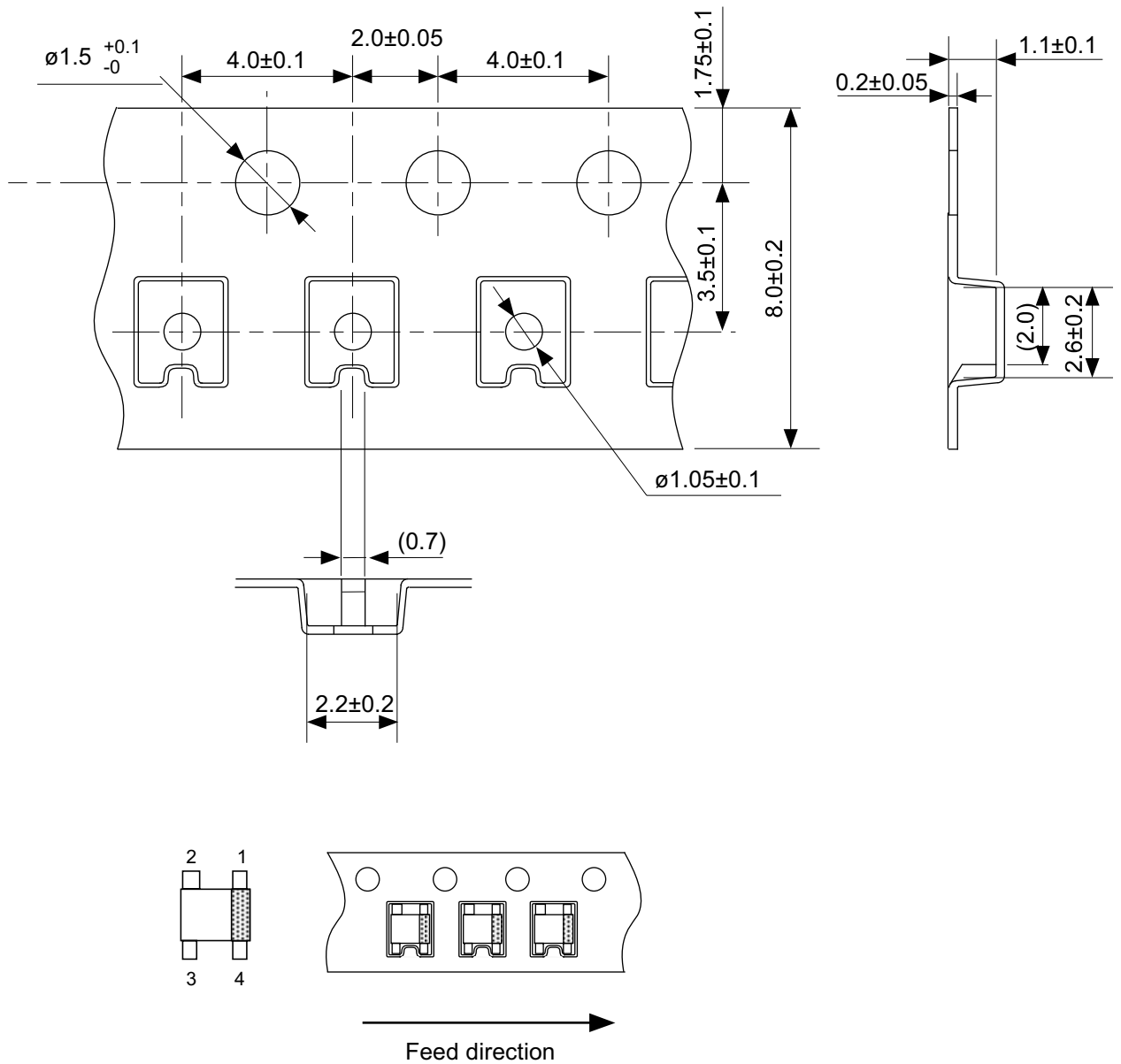

No. NP004-A-C-SD-3.0

| | |
|-------------------------------|-----------------------|
| TITLE | SC82AB-A-Carrier Tape |
| No. | NP004-A-C-SD-3.0 |
| SCALE | |
| UNIT | mm |
| | |
| SII Semiconductor Corporation | |

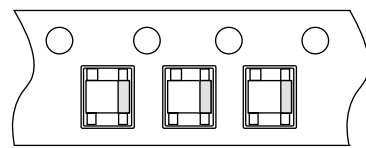
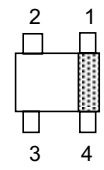
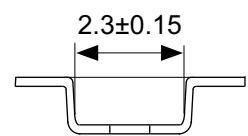
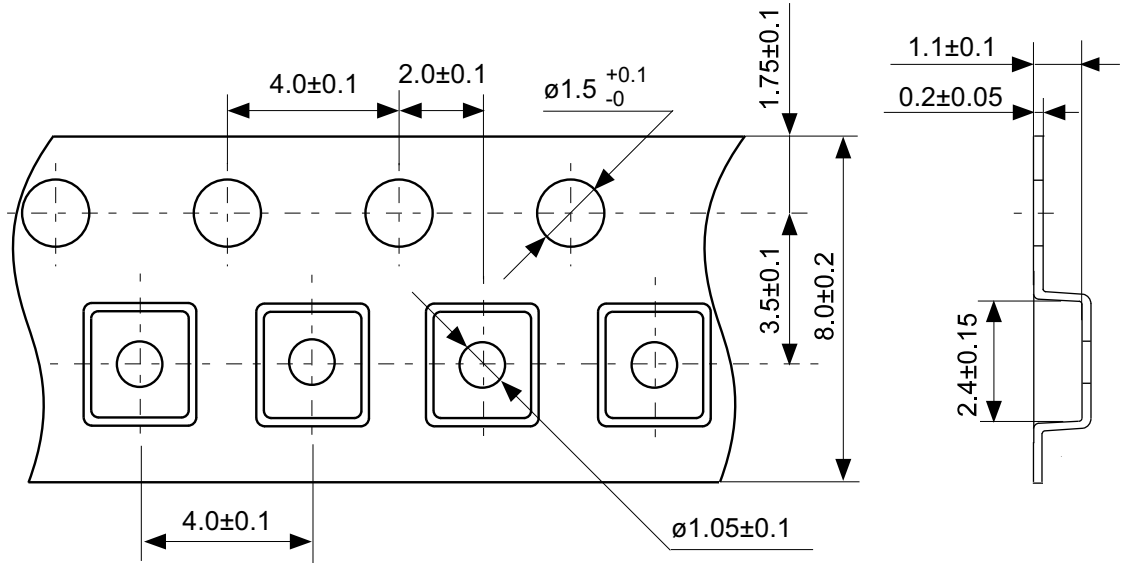

→
Feed direction

No. NP004-A-C-S1-2.0

| | |
|-------|-----------------------|
| TITLE | SC82AB-A-Carrier Tape |
| No. | NP004-A-C-S1-2.0 |
| SCALE | |
| UNIT | mm |
| | |

SII Semiconductor Corporation

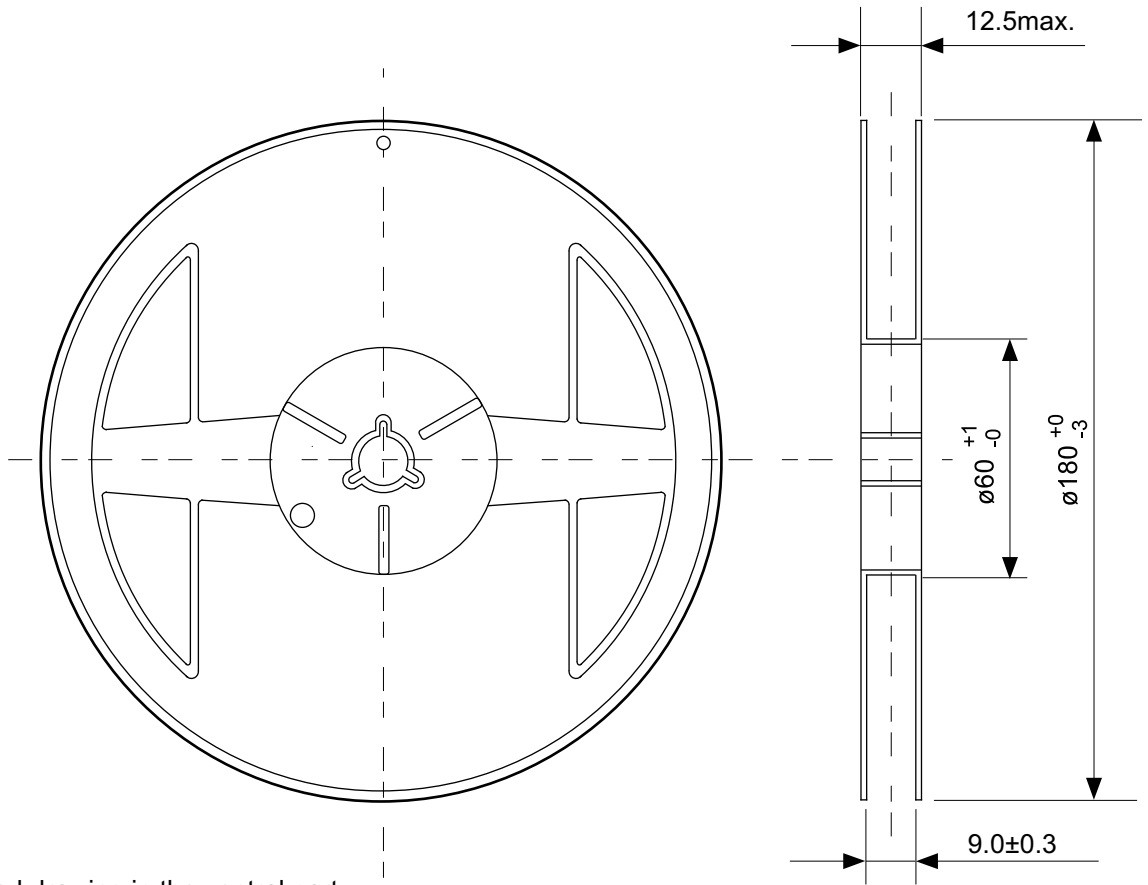

Enlarged drawing in the central part

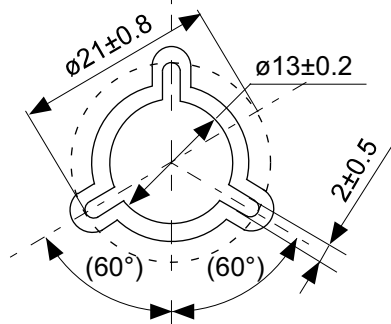

No. NP004-A-R-SD-1.1

| | | | |
|-------------------------------|------------------|------|-------|
| TITLE | SC82AB-A-Reel | | |
| No. | NP004-A-R-SD-1.1 | | |
| SCALE | | QTY. | 3,000 |
| UNIT | mm | | |
| | | | |
| SII Semiconductor Corporation | | | |

Disclaimers (Handling Precautions)

1. All the information described herein (product data, specifications, figures, tables, programs, algorithms and application circuit examples, etc.) is current as of publishing date of this document and is subject to change without notice.
2. The circuit examples and the usages described herein are for reference only, and do not guarantee the success of any specific mass-production design.
SII Semiconductor Corporation is not responsible for damages caused by the reasons other than the products or infringement of third-party intellectual property rights and any other rights due to the use of the information described herein.
3. SII Semiconductor Corporation is not responsible for damages caused by the incorrect information described herein.
4. Take care to use the products described herein within their specified ranges. Pay special attention to the absolute maximum ratings, operation voltage range and electrical characteristics, etc.
SII Semiconductor Corporation is not responsible for damages caused by failures and/or accidents, etc. that occur due to the use of products outside their specified ranges.
5. When using the products described herein, confirm their applications, and the laws and regulations of the region or country where they are used and verify suitability, safety and other factors for the intended use.
6. When exporting the products described herein, comply with the Foreign Exchange and Foreign Trade Act and all other export-related laws, and follow the required procedures.
7. The products described herein must not be used or provided (exported) for the purposes of the development of weapons of mass destruction or military use. SII Semiconductor Corporation is not responsible for any provision (export) to those whose purpose is to develop, manufacture, use or store nuclear, biological or chemical weapons, missiles, or other military use.
8. The products described herein are not designed to be used as part of any device or equipment that may affect the human body, human life, or assets (such as medical equipment, disaster prevention systems, security systems, combustion control systems, infrastructure control systems, vehicle equipment, traffic systems, in-vehicle equipment, aviation equipment, aerospace equipment, and nuclear-related equipment), excluding when specified for in-vehicle use or other uses. Do not use those products without the prior written permission of SII Semiconductor Corporation. Especially, the products described herein cannot be used for life support devices, devices implanted in the human body and devices that directly affect human life, etc.
Prior consultation with our sales office is required when considering the above uses.
SII Semiconductor Corporation is not responsible for damages caused by unauthorized or unspecified use of our products.
9. Semiconductor products may fail or malfunction with some probability.
The user of these products should therefore take responsibility to give thorough consideration to safety design including redundancy, fire spread prevention measures, and malfunction prevention to prevent accidents causing injury or death, fires and social damage, etc. that may ensue from the products' failure or malfunction.
The entire system must be sufficiently evaluated and applied on customer's own responsibility.
10. The products described herein are not designed to be radiation-proof. The necessary radiation measures should be taken in the product design by the customer depending on the intended use.
11. The products described herein do not affect human health under normal use. However, they contain chemical substances and heavy metals and should therefore not be put in the mouth. The fracture surfaces of wafers and chips may be sharp. Take care when handling these with the bare hands to prevent injuries, etc.
12. When disposing of the products described herein, comply with the laws and ordinances of the country or region where they are used.
13. The information described herein contains copyright information and know-how of SII Semiconductor Corporation.
The information described herein does not convey any license under any intellectual property rights or any other rights belonging to SII Semiconductor Corporation or a third party. Reproduction or copying of the information described herein for the purpose of disclosing it to a third-party without the express permission of SII Semiconductor Corporation is strictly prohibited.
14. For more details on the information described herein, contact our sales office.

1.0-2016.01

