

REVISIONS			
REV.	DESCRIPTION	ECN NO.	DATE
01	FIRST RELEASE FOR RFQ#A2014-13434	N/A	05/05/14

When ordering, please add suffix "T" to the part number for tape & reel packaging(13" reel).

PAGE 5 IS FOR INTERNAL ONLY

PART NUMBER		PART DESCRIPTION		TITLE										
835-01292F		RoHS compliant per EU Directive 2011/65/EU		PXFM, FLYBACK, EFD20,30W, SMD, 12 PIN										
<p align="center"><u>WARNING !</u></p> <p>ALL SHEETS OF THIS DOCUMENT ARE CONTROLLED DOCUMENTATION AND ARE NOT TO BE RELEASED OUTSIDE OF E&E OR ITS SUB-CONTRACTORS WITHOUT AUTHORIZATION.</p>	<p>UNLESS OTHERWISE SPECIFIED, DIMENSIONS ARE IN INCH/mm.</p> <p align="center"><u>TOLERANCE ARE:</u></p> <table border="0"> <tr> <td><u>INCH</u></td> <td><u>mm</u></td> <td><u>ANGLE</u></td> </tr> <tr> <td>.XXX ± .005</td> <td>.XX ± .13</td> <td>X.X ± 0.3</td> </tr> <tr> <td>.XX ± .02</td> <td>.X ± .5</td> <td>X. ± 1</td> </tr> </table>	<u>INCH</u>	<u>mm</u>	<u>ANGLE</u>	.XXX ± .005	.XX ± .13	X.X ± 0.3	.XX ± .02	.X ± .5	X. ± 1	APPROVALS	DATE	 E & E Magnetic Products Ltd.	
		<u>INCH</u>	<u>mm</u>	<u>ANGLE</u>										
		.XXX ± .005	.XX ± .13	X.X ± 0.3										
		.XX ± .02	.X ± .5	X. ± 1										
		DRAWN BY												
T. LIU	05/05/14	PROJ. ENG		DRAWING NO./MODEL	REV									
S. HONG	05/05/14	APPROVED BY												
J. YANG	05/05/14	Q.A.		835-01292F	01									
D. LUO	05/05/14													
		SCALE	PAGE	OF										
		DO NOT SCALE	1	OF	5									

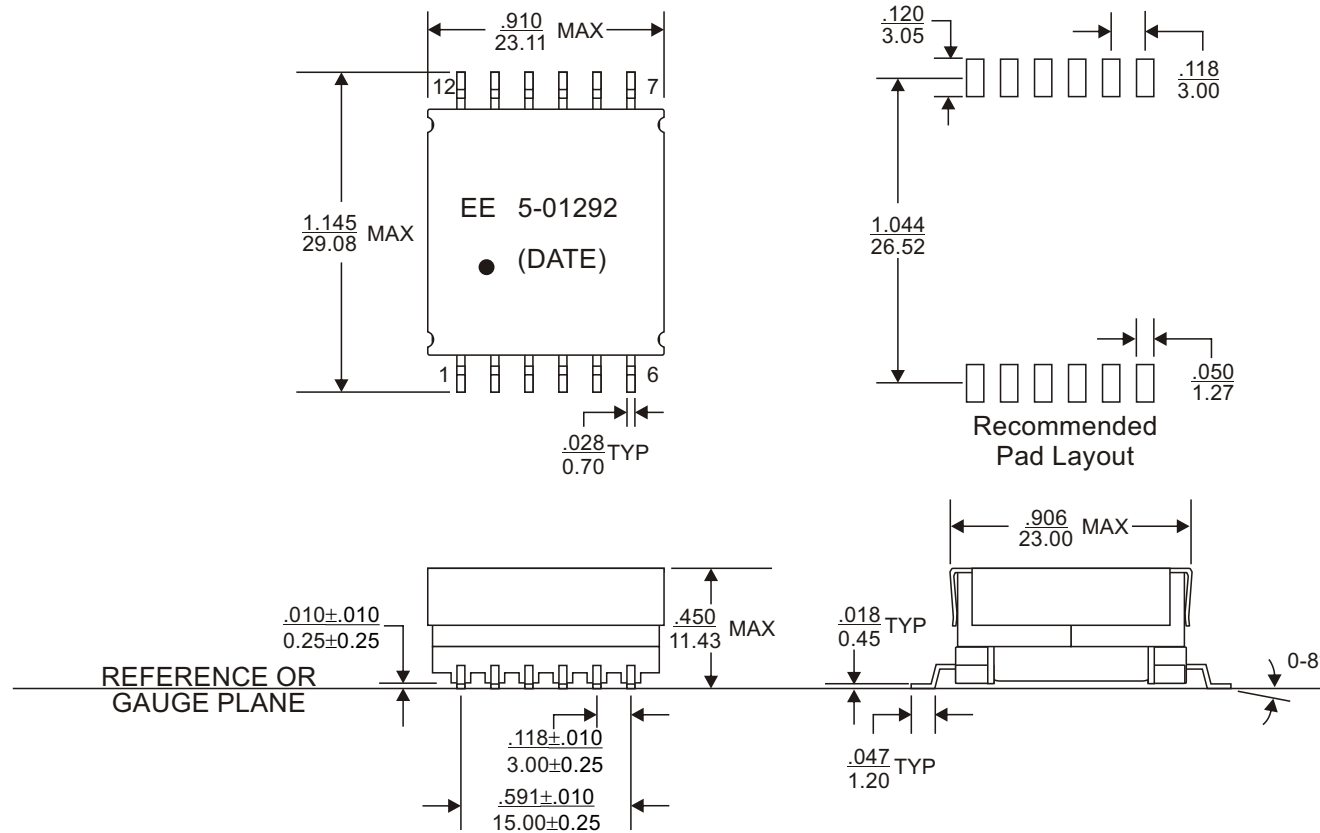

MECHANICAL OUTLINE



E & E Magnetic Products Ltd.

DRAWING NO./MODEL

835-01292F

REV

01

SCALE

DO NOT SCALE

PAGE

2

OF

5

1. Dimension are specified in $\frac{\text{inches}}{\text{mm}}$ with higher precedence in mm.

2. Unless otherwise specified, all tolerance are $\pm \frac{.010}{0.25}$.

3. Coplanarity: $\frac{.006}{0.15}$ max.

4. "(DATE)" includes at least the manufacturing date code(in YYWW format) plus manufacturing site code. .

ELECTRICAL SPECIFICATION @25°C:

PARAMETERS	UNIT	LIMITS
Turns Ratio(1-3) : (12-9)	-	2.5 : 1 ± 1%
Turns Ratio(1-3) : (11-8)	-	2.5 : 1 ± 1%
Turns Ratio(1-3) : (10-7)	-	2.5 : 1 ± 1%
Turns Ratio(1-3) : (5-6)	-	3.0 : 1 ± 1%
Turns Ratio(1-3) : (2-4)	-	1.0 : 1 ± 1%
Polarity	-	Per Schematic
Inductance, Ls(1,2-3,4)@150kHz, 0.1Vrms	uH	14 ± 10%
Leakage Inductance, LL(1,2-3,4), with 7-8-9-10-11-12 shorted, 150kHz, 0.05Vrms	uH	0.5 typ
Stauration current, 20% drop from initial	A	9.5 typ
DCR(1,2-3,4) @20°C	Ω	0.040 max
DCR(7,8,9-10,11,12) @20°C	Ω	0.010 max
DCR(5-6) @20°C	Ω	0.070 max
HIPOT(1) : (12)	Vrms	1500 1 minute or 1875 1 second

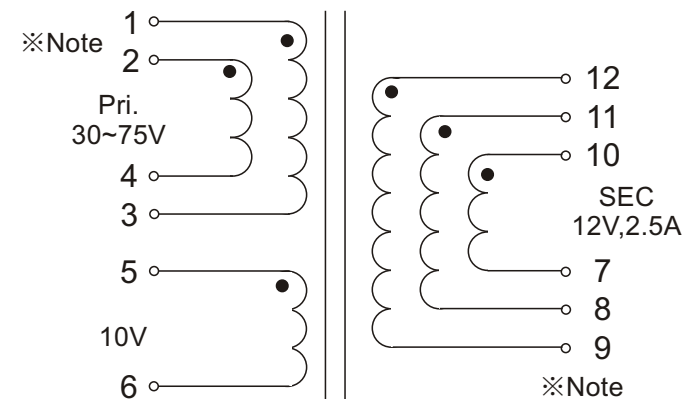

SCHEMATIC

- Operating temperature range: -40°C to +125°C. The part temperature (ambient temperature + temperature rise) should not exceed the upper limit of the operating temperature under worst case operating conditions. Circuit design, component placement, PWB trace size and thickness, airflow and other cooling provisions all affect the part temperature. Part temperature should be verified in the end application.
- The transformer is designed to meet functional insulation.
- For manufacturing, Pin 1 & 2, Pin 3 & 4, Pin 7, 8 & 9 and Pin 10, 11 & 12 can be short or open. On customer's PCB, Pin 1 & 2, Pin 3 & 4, Pin 7, 8 & 9 and Pin 10, 11 & 12 shall be connected respectively. See ※Note



E & E Magnetic Products Ltd.

DRAWING NO./MODEL

835-01292F

REV

01

SCALE

DO NOT SCALE

PAGE

3

OF

5

PACKAGING INFORMATION

(1) CONFIGURATION:(mm)

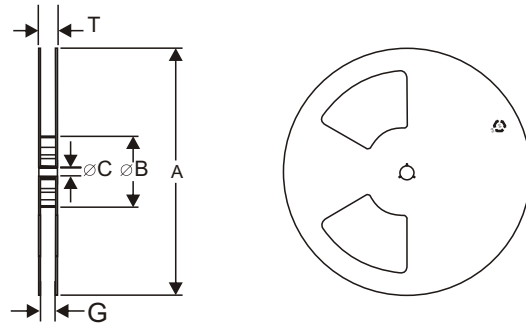

SYMBOL	A	B	C	G	T
DIM	330	100	13	44.5	49.1

(2) TAPE DIMENSIONS:(mm)

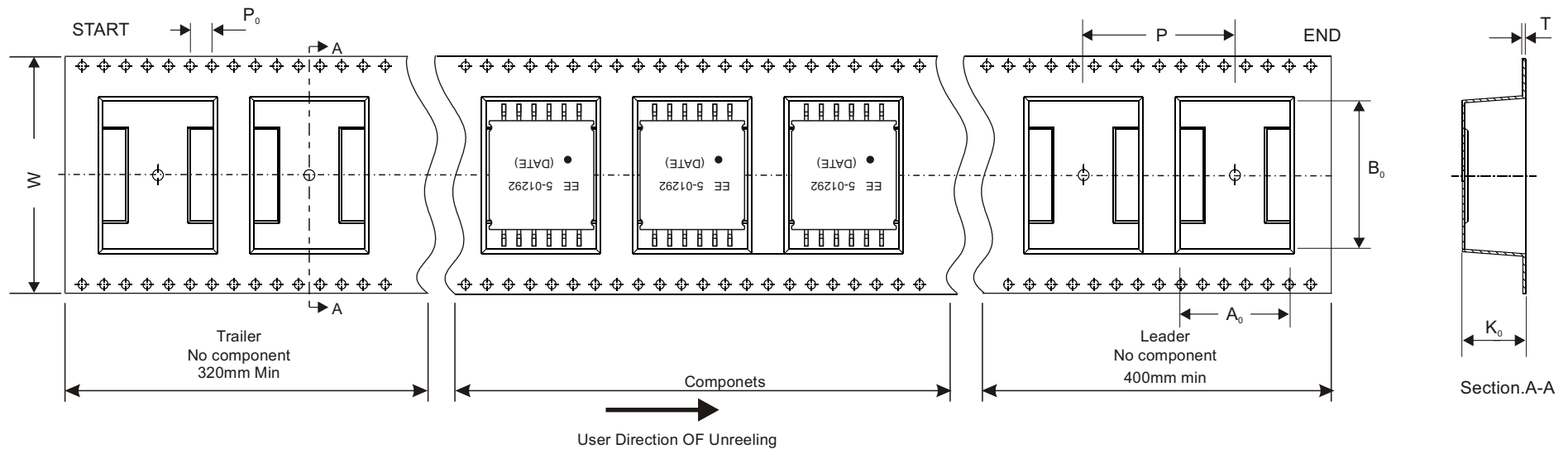

SYMBOL	A ₀	B ₀	K ₀	W	P	P ₀	T
DIM	21.40 ± 0.10	27.50 ± 0.10	11.33 ± 0.10	44.0 ^{+0.30} _{-0.00}	28.00 ± 0.10	4.00 ± 0.10	0.50 ± 0.05



E & E Magnetic Products Ltd.

DRAWING NO./MODEL

835-01292F

REV

01

SCALE

DO NOT SCALE

PAGE

4

OF

5