

# DUAL COLOR INDICATOR LAMP

## T-1 3/4 PACKAGE SOLID STATE LAMP

# MVL-504B6A

### Description

The MVL-504B6A is a water clear narrow viewing angle, dual chips, utilizing Gallium Phosphide on Gallium Phosphide green light emitting diode and Aluminum Gallium Arsenide on Gallium Arsenide red light emitting diode.

The green and red operating independently of each other with a common anode.

### Package Dimensions

Unit: mm ( inches )

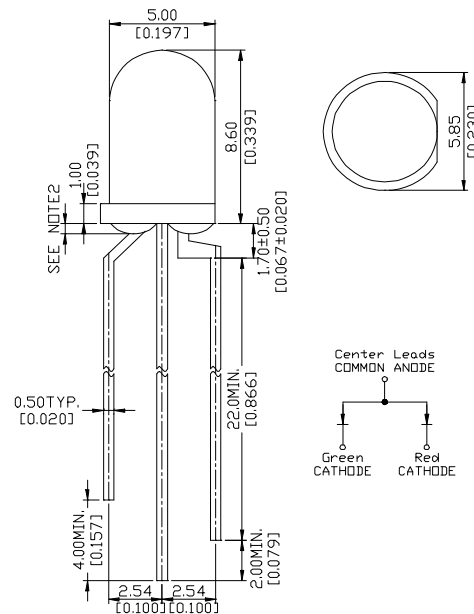

### Features

- Green and red chips are matched for uniform light output.
- Long life-solid state reliability.
- Low power consumption / I.C. compatible

#### Notes :

1. Tolerance is  $\pm 0.25$  mm (.010") unless otherwise noted.
2. Protruded resin under flange is 0.8 mm (.031") max.
3. Lead spacing is measured where the leads emerge from the package.

### Absolute Maximum Ratings

@  $T_A=25^\circ\text{C}$

Parameter	Symbol	Maximum Rating		Unit
		GREEN	RED	
Power Dissipation	$P_{ad}$	100	100	mW
Peak Forward Current(1/10 Duty Cycle 0.1ms pulse width)	$I_{pf}$	120	120	mA
Continuous Forward Current	$I_{af}$	30	40	mA
Derating Linear From 50°C		0.4	0.5	mA/°C
Reverse Voltage	$V_R$	5	5	V
Operating Temperature Range	$T_{opr}$	-55°C to + 100°C		
Storage Temperature Range	$T_{stg}$	-55°C to + 100°C		
Lead Soldering Temperature : 1.6 mm from body at 260°C for 3 seconds				

**Optical-Electrical Characteristics**

@ T<sub>A</sub>=25°C

Parameter	Test Conditions	Symbol		Min .	Typ .	Max .	Unit .
Luminous Intensity	I <sub>F</sub> =20mA	I <sub>V</sub>	GREEN/RED	35/100	100/300	-	mcd
Forward Voltage	I <sub>F</sub> =20mA	V <sub>F</sub>	GREEN/RED	-	2.1/1.8	2.8/2.6	V
Reverse Current	V <sub>R</sub> =5V	I <sub>R</sub>	GREEN/RED	-	-	100/100	μA
Peak Emission Wavelength	I <sub>F</sub> =20mA	λ <sub>p</sub>	GREEN/RED	-	565/660	-	nm
Spectral Line Half Width	I <sub>F</sub> =20mA	Δλ	GREEN/RED	-	30/20	-	nm
Viewing Angle	I <sub>F</sub> =20mA	2θ <sub>1/2</sub>	GREEN/RED	-	20/20	-	deg.

**Typical Optical-Electrical Characteristic Curves**

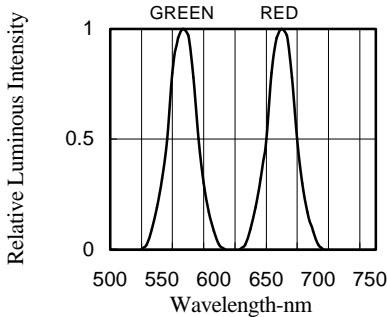

FIG.1 RELATIVE LUMINOUS INTENSITY VS. WAVELENGTH

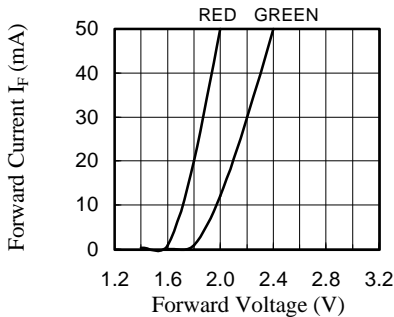

FIG.2 FORWARD CURRENT VS. FORWARD VOLTAGE

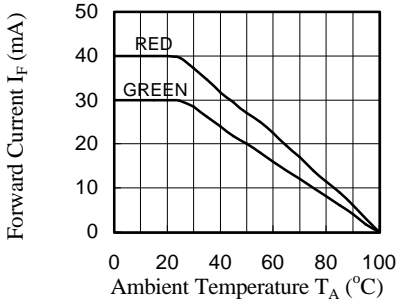

FIG.3 FORWARD CURRENT VS. AMBIENT TEMPERATURE

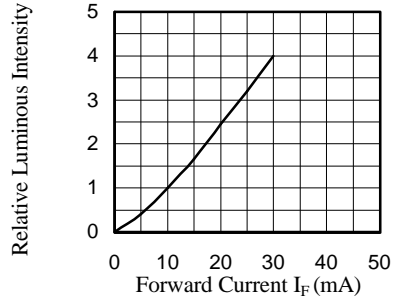

FIG.4 RELATIVE LUMINOUS INTENSITY VS. FORWARD CURRENT

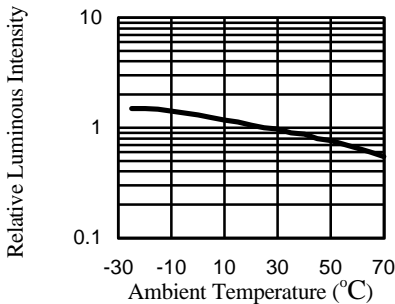

Fig 5. RELATIVE LUMINOUS INTENSITY VS. AMBIENT TEMPERATURE

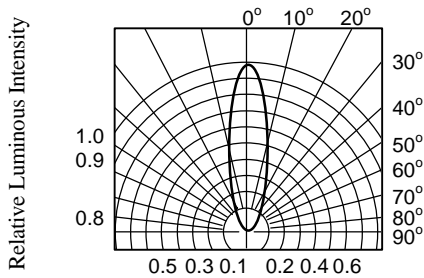

FIG.5 RADIATION DIAGRAM